

ENGINEERING
TOMORROW

Danfoss

RA2000

Commercial TRVs

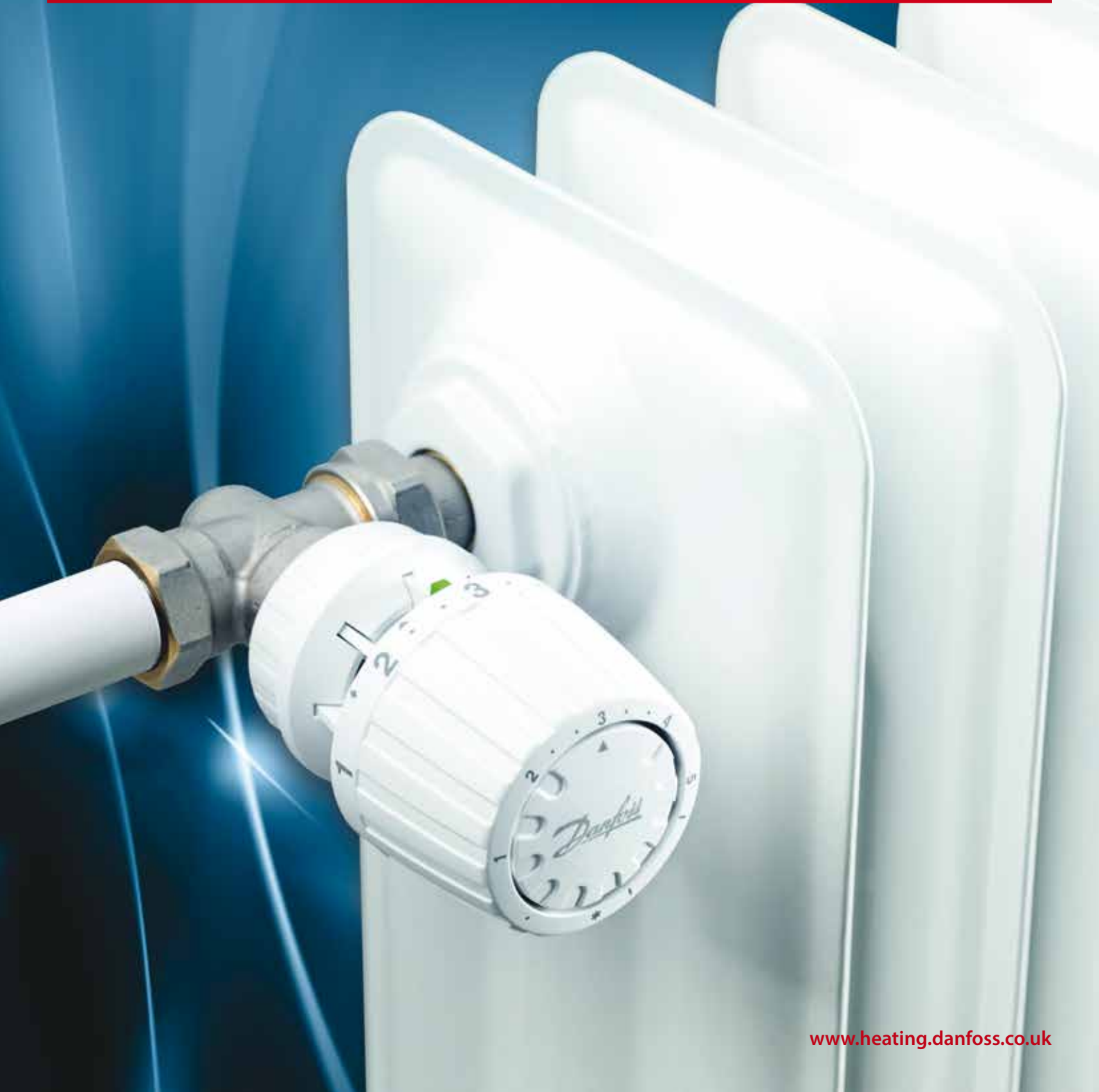

Danfoss Limited
Amphill Road
Bedford
MK42 9ER

E: ukheating@danfoss.com
W: www.heating.danfoss.co.uk

Reception

Tel: 01234 364621
Fax: 01234 219705

UK Sales

Tel: 01234 320257
Fax: 01234 320297

Customer Service

Tel: 01234 320176
Fax: 01234 320297

Training

Tel: 01234 320131

Literature

Tel: 01234 320131

Technical Support

Tel: 01234 320256
Fax: 01234 320297

Republic of Ireland

Reception

Tel: 1800 930 242

Sales

Tel: 1800 930 243
Fax: 1800 556 691

Technical Support

Tel: 1800 930 244



Thermostatic Radiator Valves

Danfoss are world leaders in the design and manufacture of radiator thermostats. Having invented the concept in 1943 Danfoss have, in the ensuing years, gone on to develop and manufacture numerous generations of radiator thermostats, offering ever improved performance.

The knowledge and experience of radiator thermostats possessed by Danfoss is unsurpassed, bringing together more than half a century of design, manufacturing and application knowledge that is second to none.

The rapid growth in the sale of radiator thermostats has, to a large extent, been down to the simplicity of the products, in terms of application and ease of use. Generally the more sophisticated the design, the more energy efficient and reliable the product is and Danfoss are at the top of the list when it comes to energy efficiency and reliability.

The need for high performance is never greater than in the demanding commercial heating market. In addition to expectations of high performance, specifiers and building owners also expect products which can withstand inevitable heavy handling and, in some cases misuse, plus be long lasting into the bargain.

The Danfoss RA2000 range is based on a saturated vapour sensor to provide the ultimate in control performance. The reason for this much improved performance is the well defined sensor location, and the small mass of the gas charge (saturated vapour) compared to other types (e.g. liquid or wax).

Contents

Working Principle of a TRV.....	4
Single Pipe and Two Pipe Systems	5
Commercial Radiator Thermostat Selection Guide.....	6-7
Working Principle of a Dynamic Valve - RA-DV	8
Pressure Independent Thermostatic Radiator Valve - RA-DV	9
Fixed Capacity Valve Bodies - RA-FN Valves for 2-Pipe Systems	10
Pre-setting Valve Bodies - RA-N Valves for 2-Pipe Systems	11
Valves for 1-Pipe System - RA-G.....	12
Combi Packs RA2000.....	13
Built-in Sensors - Standard and Tamperproof - RA2000	14
Remote Sensors and Adjusters - RA2000	15
Lockshield Valves with Drain Off - RLV.....	16
Lockshield Valves without Drain Off - RLV-S	17
H-Pieces with Drain Off - RLV-KD.....	18
H Pieces with Drain Off - RLV-KS.....	19
Spares and Accessories - Gland Seals, Sensors and Adapters.....	20
Compression Fittings for Copper, PEX and ALUPEX Pipe	21



Working Principle

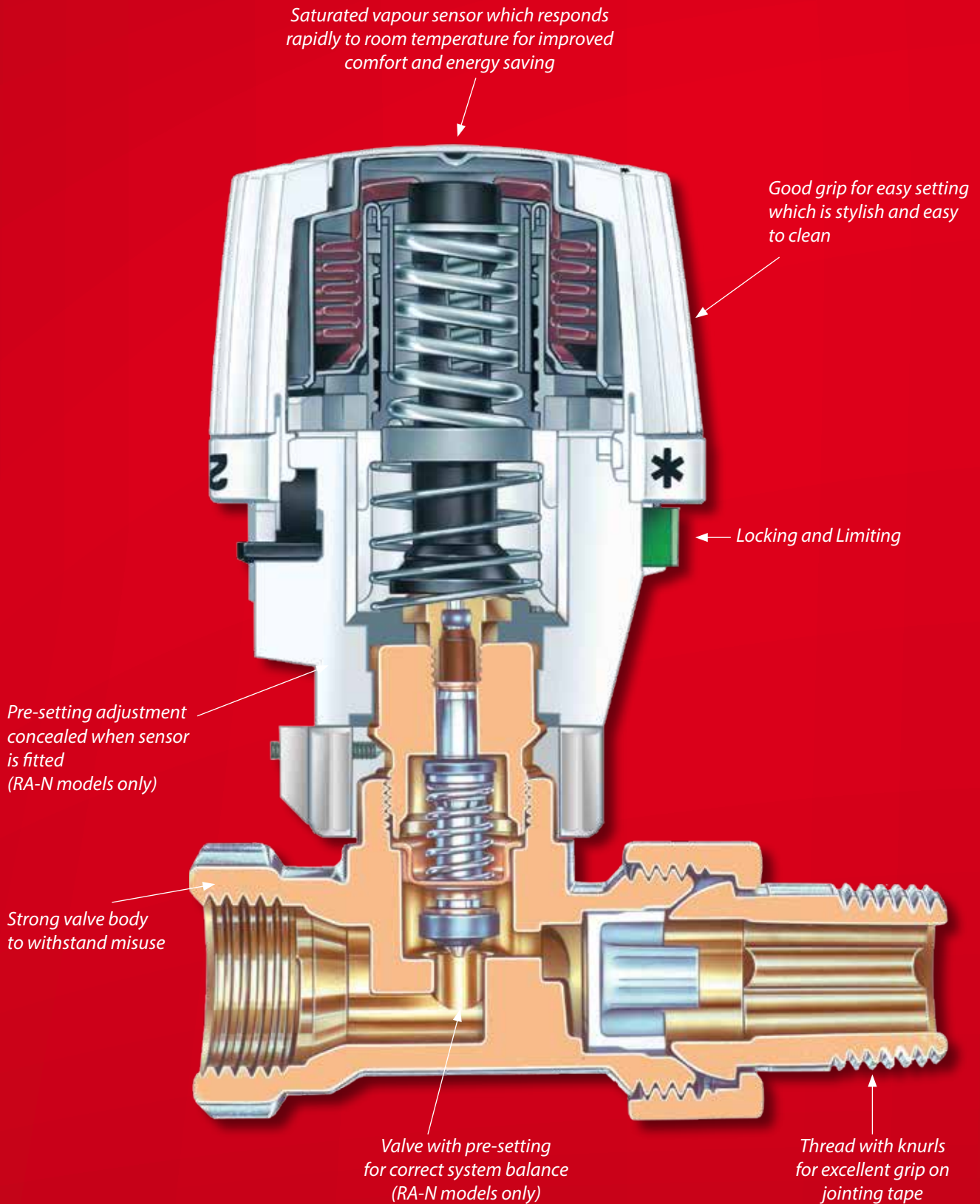

Single Pipe and Two Pipe Systems

There are two main types of radiator system, each with unique operating properties and each requiring a different valve type selection. See below for a quick guide to single and two pipe heating systems:

Single Pipe System

As the name implies, a single pipe system is a collection of radiators all connected to a single loop of pipe work throughout the building. Each radiator has the flow and return connected to the same pipe. Natural convection allowing heated water to rise into the radiator, displacing cooler water back into the single pipe circuit.

Single pipe systems can suffer from certain system specific problems:

- Because each radiator in the circuit extracts heat from the heated water, as you get further down the circuit the flow temperature is reduced requiring larger radiators to be fitted towards the end of the circuit.
- Larger pipe size required to feed the radiators.
- It is difficult to compensate for undersized radiators by increasing the water flow.

Single pipe systems are rarely fitted from new today, however many systems are still in operation and can be found in many industrial buildings, factories and schools. Designed for single pipe heating systems, the RA-G single pipe thermostatic valves have large diameter valve cones which deliver high capacity flow and control.

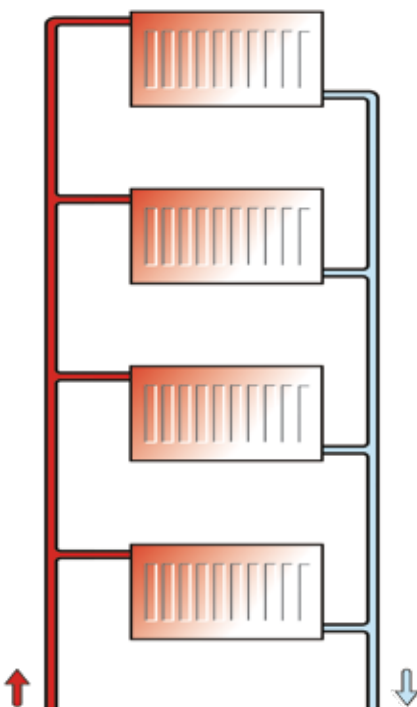
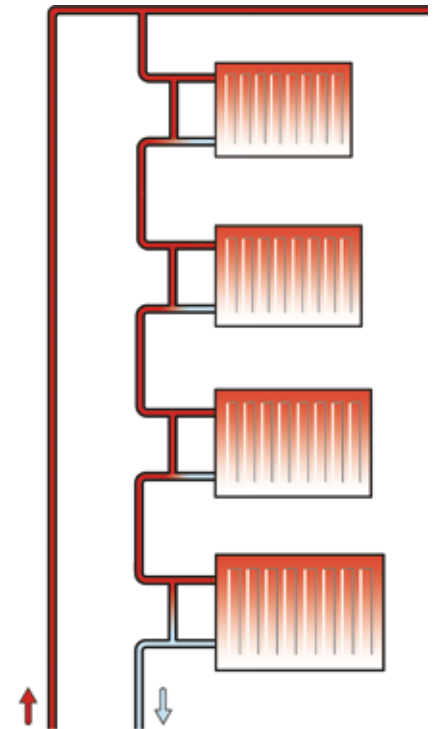

Two Pipe System

In the two pipe system there are separate flow and return pipes, with some form of bypass (preferably automatic) between the flow and the return. Because the flow and return in these systems is separate, the temperature of the water reaching each radiator is basically the same meaning radiator output is roughly the same at each branch of the circuit.

- Two pipe systems benefit from lower material costs due to pipe work and radiator surface area being smaller generally than in a one pipe system.
- Same size radiators can be used throughout the system.
- System balance is important to reduce noise and temperature variations in the system.

Two pipe systems can be fitted with pre-setting (RA-N) or fixed capacity (RA-FN) valves and RA-DV together with a thermostatic sensor from the RA2000 range.

Commercial Radiator Thermostat Selection Guide

Key

★	Approved combination Refer to notes for any restrictions/advice
1	Mount sensor horizontally
2	Consider use of remote sensor to improve performance
3	Remote sensor is recommended
4	Valve body flow selector must be commissioned

Description

Model

Codes

Temperature Range

Valve Options

		Size	Dynamic Valves		Standard Valves		Valves with pre-setting	
			Type	Code	Type	Code No.	Type	Code No.
2-Pipe System	Straight	8/10mm	-	-	RA-FS 15	013G628300	-	-
		15mm	-	-	RA-FS 15	013G628100	-	-
		½"	RA-DV 15	013G772400	RA-FN 15	013G002400	RA-N 15	013G003400
		½" / 15mm	-	-	RA-FN 15	013G008400	RA-N 15	013G0034AA
		¾"	RA-DV 20	013G772600	RA-FN 20	013G002600	RA-N 20	013G003600
		1"	-	-	RA-FN 25	013G002800	RA-N 25	013G003800
		¾"	RA-DV 10	013G772200	RA-FN 10	013G002200	RA-N 10	013G003200
	Vertical Angle	½"	RA-DV 15	013G772300	RA-FN 15	013G002300	RA-N 15	013G003300
		½" / 15mm	-	-	RA-FN 15	013G0023AA	RA-N 15	013G0033AA
		¾"	-	-	RA-FN 20	013G002500	RA-N 20	013G003500
		1"	-	-	RA-FN 25	013G002700	RA-N 25	013G003700
		¾"	RA-DV 10	013G772100	RA-FN 10	013G002100	RA-N 10	013G003100
	Horizontal Angle	½"	RA-DV 15	013G771000	-	-	RA-N 15	013G015300
		½" / 15mm	-	-	RA-FN 15	013G014900	RA-N 15	013G0153AA
		¾"	RA-DV 20	013G772500	RA-FN 20	013G014500	RA-N 20	013G015500
1"		-	-	-	-	-	-	
¾"		RA-DV 10	013G770900	RA-FN 10	013G014100	RA-N 10	013G015100	
1-Pipe System	Straight	½"	-	-	RA-G 15	013G167500	-	-
		¾"	-	-	RA-G 20	013G167700	-	-
		1"	-	-	RA-G 25	013G167900	-	-
	Vertical Angle	½"	-	-	RA-G 15	013G167600	-	-
		¾"	-	-	RA-G 20	013G167800	-	-
		1"	-	-	RA-G 25	013G168000	-	-



	Built-in Sensors				Remote Sensors (0-2m)			2/5/8m Wall Adjusters
	Standard	Standard Snap On Mount	Low Temp.	Tamperproof	Standard	Low Temp.	Tamperproof	
								
	RA2910	RA2990	RA2914	RA2920	RA2912	RA2916	RA2922	RA5062 RA5065 RA5068 RA5075
	013G291000	013G299000	013G291400	013G292000	013G291200	013G291600	013G292200	013G506200 013G506500 013G506800 013G507500
	5-26°C	5-26°C	5-22°C	5-26°C	5-26°C	5-22°C	5-26°C	6-28°C
	Sensor Options							
	4 ★	4 ★	4 ★	4 ★	4 ★	4 ★	4 ★	4 ★
	1 ★	1 ★	1 ★	1 ★	★	★	★	★
	2 ★	2 ★	3 ★	2 ★	★	★	★	★
	★	★	★	★	★	★	★	★
	1 ★	1 ★	1 ★	1 ★	★	★	★	★
	2 ★	2 ★	3 ★	2 ★	★	★	★	★

Working Principle

RA-DV

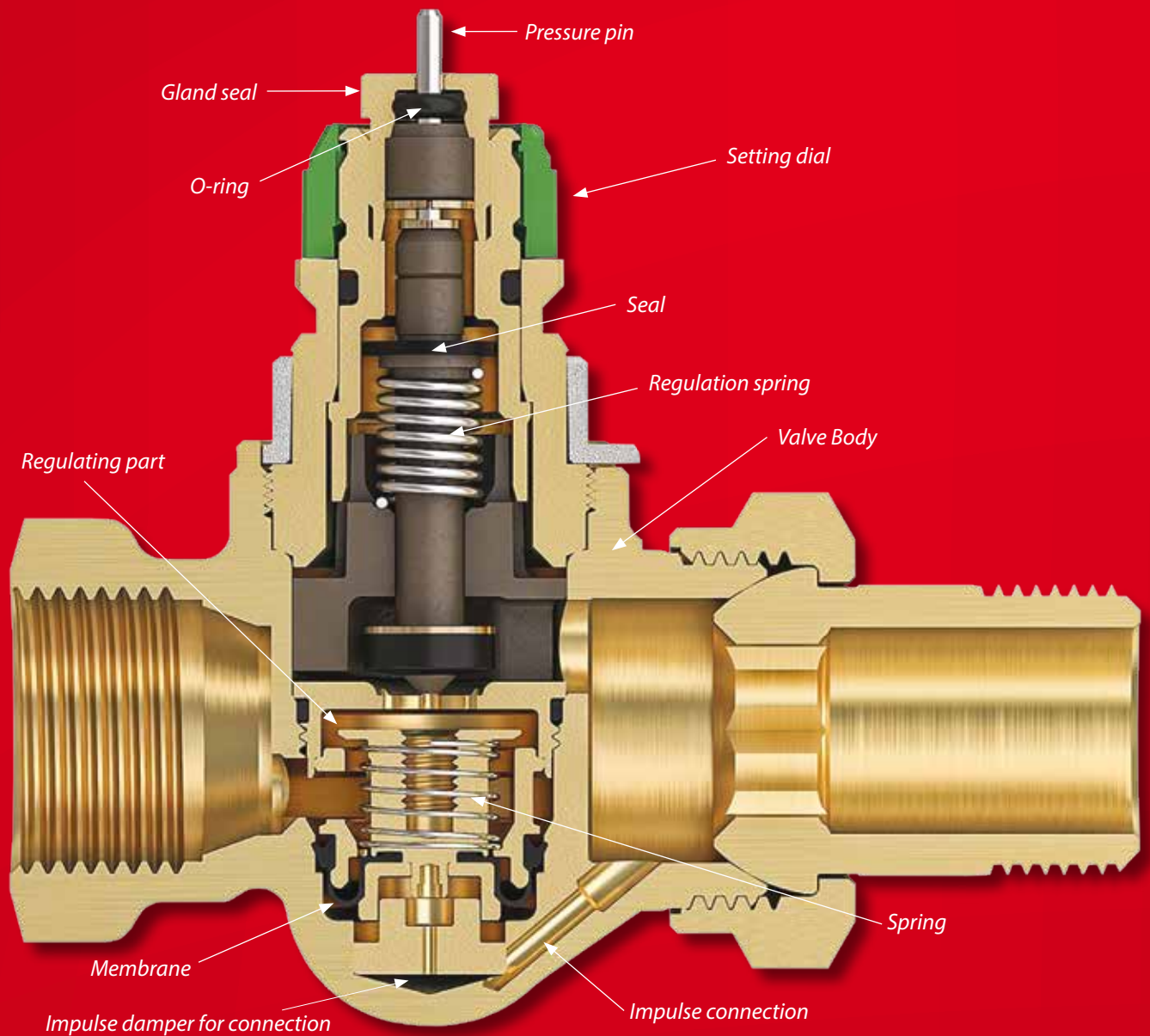

Pressure Independent Thermostatic Radiator Valve

RA-DV



- Fast consistent and comfortable heating
- Reduced system noise
- Reduced costs

Automatic balancing provides instant benefits under full and partial load conditions. It is quick and easy to achieve and is a one-off investment with a fast payback time.

Eliminating pressure fluctuations is the key to both successful balancing and removing the source of user complaints about over or under-heating, noise and excessive energy costs.

At the same time, the temperature control will benefit from the optimised system conditions, making room temperature more stable and precise.

RA-DV valves are suitable for use with all RA2000 sensors and may also be used with RAS-D² and RAS-C² sensors. Please refer to our technical department for capacity information if using RAS-D² or RAS-C² sensors.

Please refer to page 21 for fittings.



Description	Model	Version	Connection	Flow (l/h)*	Code Number
RA-DV 10	UK (Axial)	DIN	3/8"	25-125	013G770900
RA-DV 10	Angle	DIN	3/8"	25-125	013G772100
RA-DV 10	Straight	DIN	3/8"	25-125	013G772200
RA-DV 15	UK (Axial)	DIN	1/2"	25-125	013G771000
RA-DV 15	Angle	DIN	1/2"	25-125	013G772300
RA-DV 15	Straight	DIN	1/2"	25-125	013G772400
RA-DV 20	Angle	DIN	3/4"	25-125	013G772500
RA-DV 20	Straight	DIN	3/4"	25-125	013G772600

* 20-125 l/h including a gas filled RA2000 sensor

Description	Code Number
Pre-setting tool For easy pre-setting of a Dynamic Valve	013G783000

Description	Code Number
ΔP tool For simple verification of sufficient differential pressure and pump optimisation	013G785500

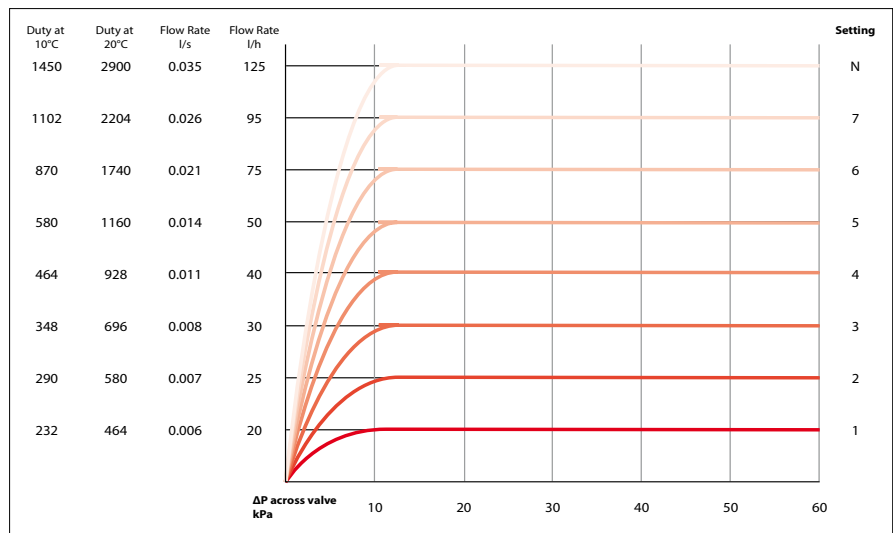

Solutions	Pressure	Radiator	System	Economy
Radiator fitted with RA-DV 	Max. differential pressure = 60 kPa	Max. flow = 125 l/h P = 3140 W at ΔT = 20K P = 4700 W at ΔT = 30K	<ul style="list-style-type: none"> • Best choice for complex riser designs • Best choice when main risers/return pipes are difficult to access • Best choice when main riser/return pipes are distant from each other 	Best choice for risers with few radiators

Fixed Capacity Valve Bodies

RA-FN Valves for 2-Pipe Systems



- RA-FN valves without pre-setting
- RA-FN valves are easily recognised by a grey cover cap
- May also be used with RAS-D² and RAS-C² sensors (RA-FN only)
- Wide range of fittings (see page 21)

RA-FN valves are designed for use in 2-pipe heating systems where circulation through both pipe work and radiator is pumped. They are conventional uni-directional valves without pre-setting; system balancing must be made using lockshield valves installed on the radiator return connection. Please refer to pages 16 and 17 for matching lockshield valves.

A wide range of compression fittings for copper, PEX and ALUPEX pipe are available for use with RA-FN valves, see page 21.

All valves incorporate a gland-seal assembly that can be replaced without the need for special tools and without draining down the system.

RA-FN valves are suitable for use with all RA2000 sensors and may also be used with RAS-D² and RAS-C² sensors. Please refer to our technical department for capacity information if using RAS-D² or RAS-C² sensors.

Pattern	Type	Code No	Connections		Kv Value Xp = 2K ⁽²⁾
			Pipe	Radiator Tail	
Straight	RA-FN 10	013G002200	3/8" BSP	3/8" BSP	0.56
	RA-FN 15	013G002400	1/2" BSP	1/2" BSP	0.73
	RA-FN 15	013G008400	15mm or 1/2" BSP	1/2" BSP	0.73
	RA-FN 20	013G002600	3/4" BSP	3/4" BSP	1.04
	RA-FN 25	013G002800	1" BSP	1" BSP	1.04
Vertical Angle ⁽¹⁾	RA-FN 10	013G002100	3/8" BSP	3/8" BSP	0.56
	RA-FN 15	013G002300	1/2" BSP	1/2" BSP	0.73
	RA-FN 15	013G0023AA	15mm or 1/2" BSP	1/2" BSP	0.73
	RA-FN 20	013G002500	3/4" BSP	3/4" BSP	1.04
	RA-FN 25	013G002700	1" BSP	1" BSP	1.04
Horizontal Angle	RA-FN 10	013G014100	3/8" BSP	3/8" BSP	0.56
	RA-FN 15 UK	013G014900	15mm or 1/2" BSP	1/2" BSP	0.73
	RA-FN 20	013G014500	3/4" BSP	3/4" BSP	0.80

(1) To ensure optimum performance use remote sensor

(2) Kv values when used with RA2000 sensors

Technical Specifications

Maximum Operating Temperature	120°C
Maximum Working Pressure	10 Bar
Maximum Differential Pressure	0.6 Bar

Pattern	Type	D	d ₂ BSP	L ₁	L ₂	L ₃	L ₄	L ₅	L ₆	L ₇ *	L ₈	L ₉	L ₁₀	L ₁₁	Arc. Flats	
															S ₁	S ₂
Straight	RA-FN 10	3/8"	3/8"	60	85				47	96					22	27
	RA-FN 15	1/2"	1/2"	67	95				47	96					27	30
	RA-FN 20	3/4"	3/4"	74	106				52	101					32	37
	RA-FN 25	1"	1"	90	126				52	101					41	46
Vertical Angle	RA-FN 10	3/8"	3/8"		27	52	22	47	96						22	27
	RA-FN 15	1/2"	1/2"		30	58	26	47	96						27	30
	RA-FN 20	3/4"	3/4"		34	66	29	52	101						32	37
	RA-FN 25	1"	1"		40	75	34	52	101						41	46
Horizontal Angle	RA-FN 10	3/8"	3/8"					59	108	26	51	22			22	27
	RA-FN 15 UK	1/2"	1/2"					60	98	26	54	33	44		27	30
	RA-FN 20	3/4"	3/4"					61	110	34	66	30			32	27

* Add 32mm to L₇, to allow for sensor removal.

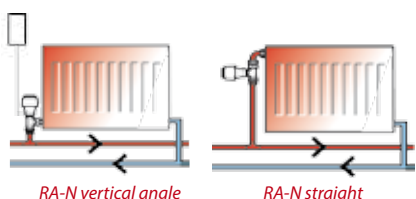
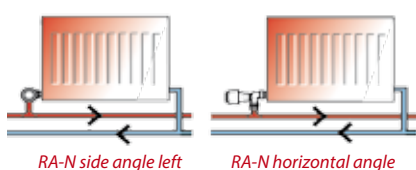

Straight
RA-N or RA-FN

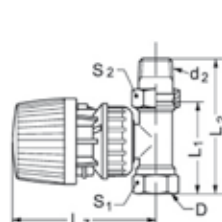

Vertical Angle
RA-N
or RA-FN

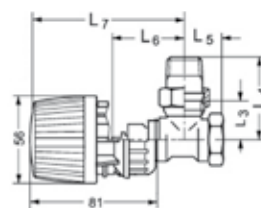

Horizontal Angle
RA-N 10, 15, 20
&
RA-FN 10 or 20

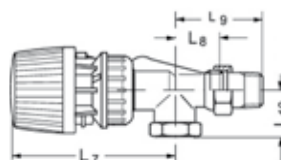

Horizontal Angle
RA-FN 15 UK

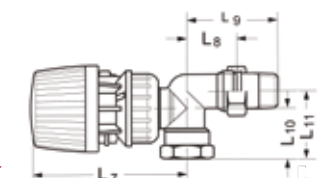

Pre-Setting Valve Bodies RA-N Valves for 2-Pipe Systems

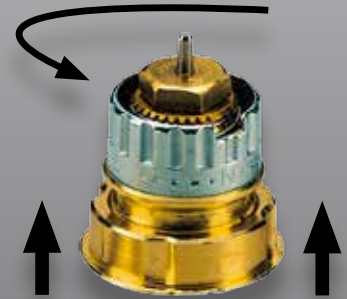
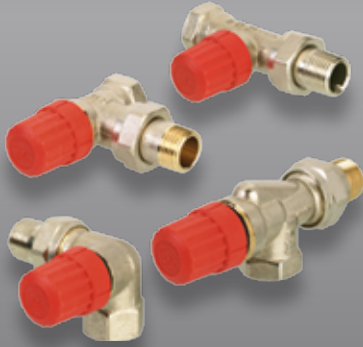

Pattern	Type	Code No	Connections		Kv Value ⁽¹⁾⁽³⁾ Xp = 2K	
			Pipe	Radiator Tail	Min	Max
Straight	RA-N 10	013G003200	3/8" BSP	3/8" BSP	0.04	0.56
	RA-N 15	013G003400	1/2" BSP	1/2" BSP	0.04	0.73
	RA-N 15	013G0034AA	15mm or 1/2" BSP	1/2" BSP	0.04	0.73
	RA-N 20	013G003600	3/4" BSP	3/4" BSP	0.10	1.04
	RA-N 25	013G003800	1" BSP	1" BSP	0.10	1.04
Vertical Angle ⁽²⁾	RA-N 10	013G003100	3/8" BSP	3/8" BSP	0.04	0.56
	RA-N 15	013G003300	1/2" BSP	1/2" BSP	0.04	0.73
	RA-N 15	013G0033AA	15mm or 1/2" BSP	1/2" BSP	0.04	0.73
	RA-N 20	013G003500	3/4" BSP	3/4" BSP	0.10	1.04
	RA-N 25	013G003700	1" BSP	1" BSP	0.10	1.04
Horizontal Angle	RA-N 10	013G015100	3/8" BSP	3/8" BSP	0.04	0.56
	RA-N 15	013G015300	1/2" BSP	1/2" BSP	0.04	0.73
	RA-N 15	013G0153AA	15mm or 1/2" BSP	1/2" BSP	0.04	0.73
	RA-N 20	013G015500	3/4" BSP	3/4" BSP	0.16	0.80
Side Angle ⁽⁴⁾	RA-N 10L	013G023100	3/8" BSP	3/8" BSP	0.04	0.56
	RA-N 10R	013G023200	3/8" BSP	3/8" BSP	0.04	0.56
	RA-N 15L	013G233000	1/2" BSP	1/2" BSP	0.04	0.73
	RA-N 15R	013G023400	1/2" BSP	1/2" BSP	0.04	0.73

(1) Kv value at Xp=2 when used with RA2000 sensors. (2) To ensure optimum performance use remote sensor.
(3) Refer to setting table supplied with valves to adjust Kv. (4) L = Left, R = Right

Technical Specifications

Maximum Operating Temperature	120°C
Maximum Working Pressure	10 Bar
Maximum Differential Pressure	0.6 Bar

- RA-N valves with pre-setting for larger heating systems
- RA-N valves in flow
- RA-N valves are easily recognised by a red cover cap
- Available in vertical angle, horizontal angle, side angle and straight pattern versions in 3/8", 1/2", and 1" sizes

RA-N are uni-directional valves with integrated pre-setting. Pre-setting allows the commissioning engineer to precisely set the flow rate through the valve by adjusting the valve capacity to match the radiator heat output requirement.

Pre-setting is carried out by setting a calibrated orifice within the valve. The setting is achieved by turning a scale located in the top part of the valve body. The setting mechanism is concealed once the thermostat sensor is fitted. This type of pre-setting is significantly more accurate than that possible with conventional lockshield valves. When pre-setting valves are used the role of the lockshield valve is simply to provide isolation for radiator removal.

Pattern	Type	D d ₂ BSP	L ₁	L ₂	L ₃	L ₄	L ₅	L ₆	L ₇ *	L ₈	L ₉	L ₁₀	Arc. Flats		
													S ₁	S ₂	
Straight	RA-N 10	3/8"	3/8"	60	85				47	96				22	27
	RA-N 15	1/2"	1/2"	67	95				47	96				27	30
	RA-N 20	3/4"	3/4"	74	106				52	101				32	37
	RA-N 25	1"	1"	90	126				52	101				41	46
Vertical Angle	RA-N 10	3/8"	3/8"			27	52	22	47	96				22	27
	RA-N 15	1/2"	1/2"			30	58	26	47	96				27	30
	RA-N 20	3/4"	3/4"			34	66	29	52	101				32	37
	RA-N 25	1"	1"			40	75	34	52	101				41	46
Horizontal Angle	RA-N 10	3/8"	3/8"						59	108	26	51	22	22	27
	RA-N 15	1/2"	1/2"						60	109	26	55	27	27	30
	RA-N 20	3/4"	3/4"						61	110	34	66	30	32	27
Side Angle	RA-N 10	3/8"	3/8"						47	103	27	52	27	22	27
	RA-N 15	1/2"	1/2"						47	96	30	58	33	27	30

* Add 32mm to L₇ to allow for sensor removal.

RA-N 10 Guideline basis RA2000 sensor					RA-N 15 Guideline basis RA2000 sensor				
ΔT(K)					ΔT(K)				
10K	15K	20K	[Symbol]		10K	15K	20K	[Symbol]	
~Watt					~Watt				
100	200	250	1		100	200	250	1	
250	400	550	2		250	400	550	2	
400	650	850	3		400	650	850	3	
650	1000	1350	4		700	1100	1450	4	
900	1350	1800	5		1100	1650	2150	5	
1200	1800	2400	6		11450	2150	2900	6	
1350	2050	2750	7		1850	2800	3700	7	
2050	3050	4100	N		2650	4000	5350	N	

RA-N 20 Guideline basis RA2000 sensor					RA-N 20 UK Guideline basis RA2000 sensor				
ΔT(K)					ΔT(K)				
10K	15K	20K	[Symbol]		10K	15K	20K	[Symbol]	
~Watt					~Watt				
350	550	700	1		550	850	1150	1	
550	800	1100	2		700	1100	1450	2	
600	900	1200	3		900	1350	1800	3	
950	1400	1900	4		1250	1900	2550	4	
1250	1900	2550	5		1700	2550	3400	5	
1650	2500	3350	6		2150	3250	4350	6	
2650	4000	5350	7		2650	4000	5350	7	
3800	5700	7600	N		2900	4350	5850	N	

Valves for 1-Pipe Systems

RA-G

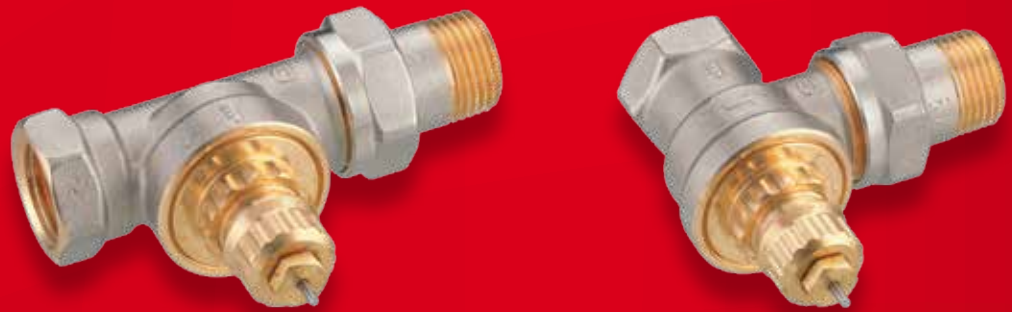

- RA-G valves in flow
- Suitable for use with all RA2000 sensors
- Available in both vertical angle and straight pattern designs in 1/2", 3/4" and 1" sizes

RA-G valves are high capacity low resistance valves for use in conventional 1-pipe heating systems in which water circulation through the radiator is mainly by thermosiphon. In such systems the circulating pressure available to overcome the frictional resistance of the valve and the radiator is extremely low and is generally insufficient to overcome the resistance of normal 2-pipe radiator thermostats.

RA-G valves are specifically designed for use in such systems and have large diameter valve cones which deliver high capacities at low proportional offsets ensuring that comfort temperatures can be maintained under all load conditions.

All valves incorporate a gland-seal assembly that can be replaced without the need for special tools and without draining down the system.

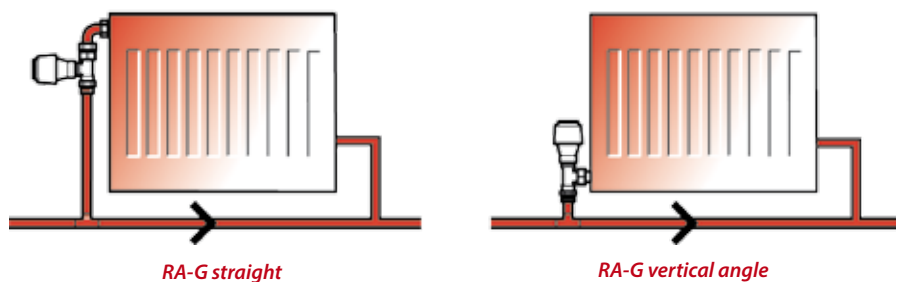

Pattern	Type	Code No	Connections		Kv Value Xp = 2K ⁽²⁾
			Pipe ⁽³⁾	Radiator Tail	
Straight	RA-G 15	013G167500	1/2" BSP	1/2" BSP	1.63
	RA-G 20	013G167700	3/4" BSP	3/4" BSP	2.06
	RA-G 25	013G167900	1" BSP	1" BSP	2.27
Vertical Angle ⁽¹⁾	RA-G 15	013G167600	1/2" BSP	1/2" BSP	2.06
	RA-G 20	013G167800	3/4" BSP	3/4" BSP	2.20
	RA-G 25	013G168000	1" BSP	1" BSP	2.41

Please note:
 (1) To ensure optimum performance use remote sensor
 (2) Kv values when used with RA2000 Sensors
 (3) Not suitable for use with Fittings listed on page 223

Technical Specifications	
Maximum Operating Temperature	120°C
Maximum Working Pressure	10 Bar
Maximum Differential Pressure (RA-G 25)	0.16 Bar
Maximum Differential Pressure (RA-G 15 & 20)	0.2 Bar

Type	DN	D	d ₂	L ₁	L ₂	L ₃	L ₄	L ₅	L ₆	L ₇	S ₁	S ₂
RA-G 15	15	1/2"	1/2"	68	96	30	58	27	52	103	27	30
RA-G 20	20	3/4"	3/4"	74	106	34	66	30	54	103	32	37
RA-G 25	25	1"	1"	90	126	42	78	34	57	106	41	46

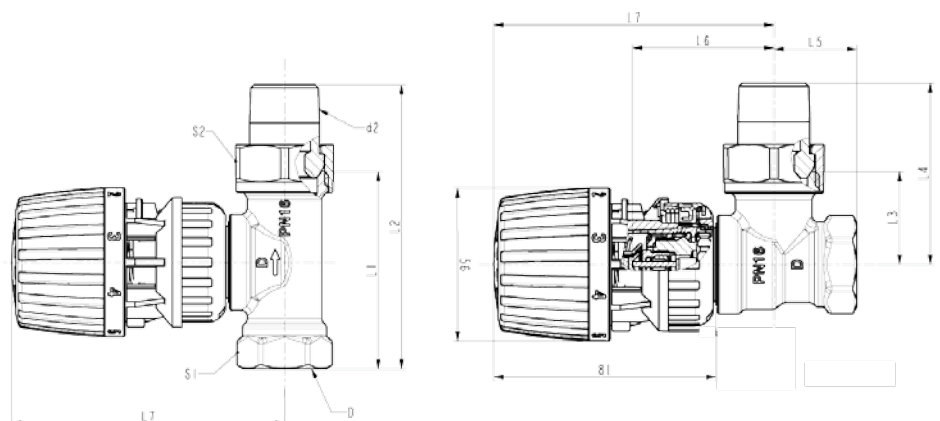

Combi Packs RA2000



Application

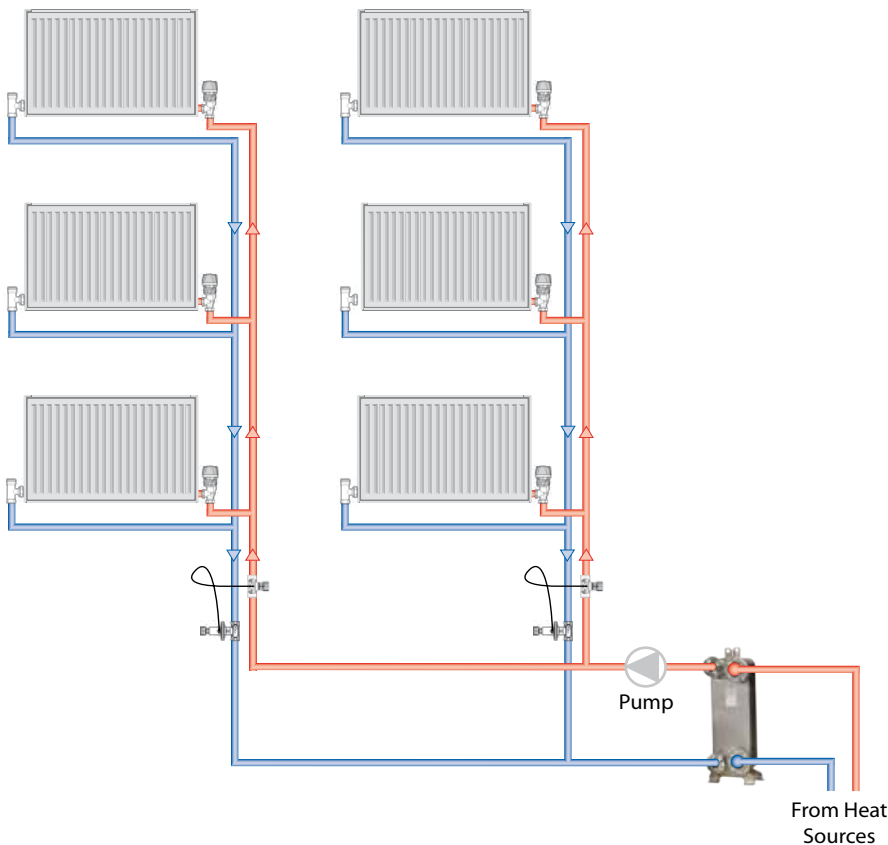

- Convenient pack based solution
- Packs available with or without lockshield
- 4 unique valve combinations covering the most popular RA2000 combinations

Complementing the range of individual separates available in the RA2000 range are the RA2000 Combi Packs. The range of four packs brings together the most popular RA2000 components into a convenient package allowing for simple ordering of all components with one code number.

Packs come complete with a standard RA2910 thermostatic head and are available in either ½" (complete with 15mm compression adaptors) or ¾" variations and with or without a lockshield valve.

Description	Contains	Code No
Vertical Angle ½" / 15mm Combi pack	1 x RA2910 Thermostatic Head 1 x RA-FN15 Valve (inc. 15mm compression fitting)	013G602100
Vertical Angle ¾" Combi Pack	1 x RA2910 Thermostatic Head 1 x RA-FN20 Valve	013G602200
Vertical Angle + Lockshield Valve ½" / 15mm Combi Pack	1 x RA2910 Thermostatic Head 1 x RA-FN15 Valve (inc. 15mm compression fitting) 1 x RLV-S15 ½"/15mm Lockshield	013G602300
Vertical Angle + Lockshield Valve ¾" Combi Pack	1 x RA2910 Thermostatic Head 1 x RA-FN20 Valve 1 x RLV-S20 ¾" Lockshield	013G602400

Built-in Sensors

RA-2000



- RA2910 temperature range 5-26°C
- RA2920 tamperproof
- RA2990 tool free installation
- All models have locking and limiting feature
- Use with RA-N, RA-FN or RA-G valves

RA2000 sensors are high performance temperature sensors ideally suited for commercial applications. The temperature sensor uses frictionless bellows charged with a small volume of liquified gas.

The sensor relies upon the state change from liquid to a gas as the temperature of the liquid increases to modulate the valve towards the closed position. When the temperature falls the gas condenses back to a liquid and the spring within the sensor allows the valve to modulate open until the bellows pressure and spring pressure are equal, and the valve cone is stationary.

This type of saturated vapour pressure sensor has many advantages including low thermal mass giving quick reaction times and a defined sensor location at coolest part of bellows system.

This latter feature gives the product a very low flow temperature dependence making it ideal for use in systems with weather compensated flow temperatures.

The range includes standard temperature range (5-26°C) and low temperature range (5-22°C) models. Both incorporate range locking and limiting features that allow the commissioning engineer to lock or limit the setting range of the sensor.

For best performance built-in temperature sensors should be mounted horizontally. Care should be taken not to cover the thermostat or to locate it where it may be influenced by heat from electrical appliances or cold draughts.

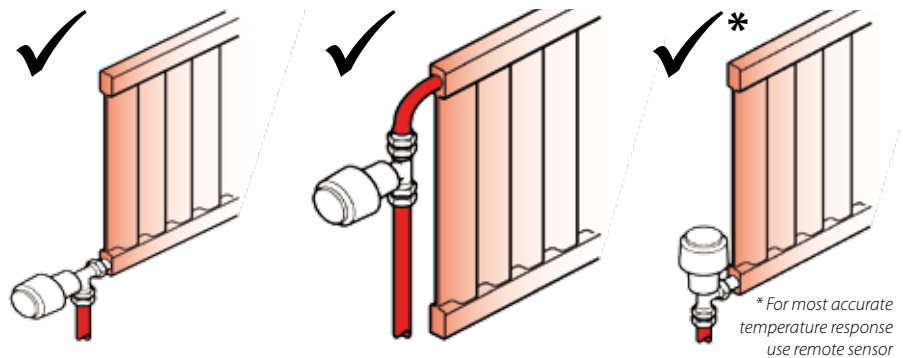

Type	Code No	Sensor (max. sensor temp 60°C)	Temp Range Xp = 2K
RA2910	013G291000	Built-in	5-26°C
RA2914	013G291400	Built-in, low temperature range model	5-22°C
RA2990 ¹	013G299000	Built-in	5-26°C
RA2920 ²	013G292000	Tamperproof	5-26°C
RA2912	013G291200	Remote Sensor	5-26°C
RA2916	013G291600	Remote Sensor	5-22°C
RA2922	013G292200	Remote Sensor, tamperproof	5-26°C

¹ Snap on coupling (Easy installation without the use of tools)
² Toolkit required

Locking and Limiting

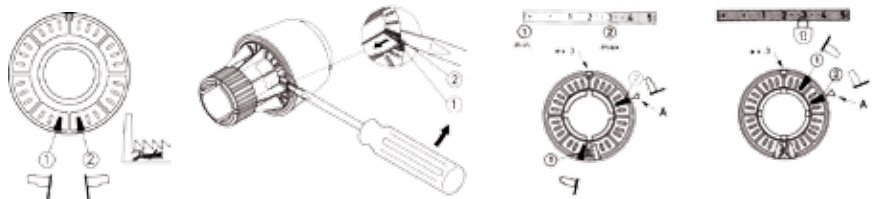

Standard Sensor Mounting

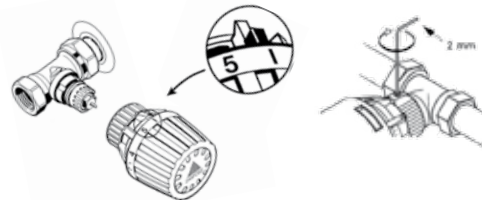

Snap Sensor Mounting

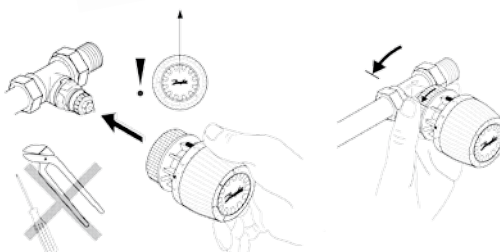

Remote Sensors and Adjusters

RA2000

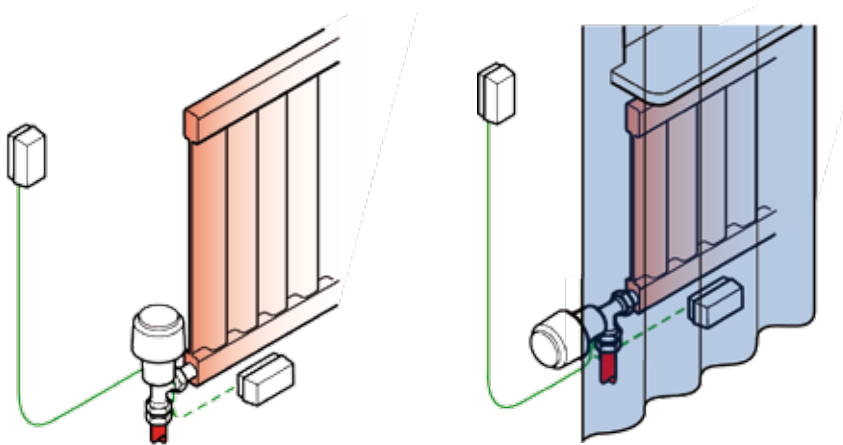

- All models have locking and limiting
- Capillary can be adjusted between 0-2 metres on remote sensors
- Remote adjusters available
- Use with RA-N, RA-FN or RA-G valves

Utilising the same sensor technology as the built-in sensor, remote sensors are ideal for use in situations where built-in sensors may be adversely affected by heat gains or cold draughts.

Remote sensors comprise a setting unit that is mounted on the valve and a remote sensor which can be located up to 2 metres from the setting unit. The two components are interconnected by an ultra-thin capillary tube. During installation, the required length of tube is pulled out and fixed to the wall with clips or by staple gun.

RA2000 Remote Sensors

Type	Code No	Sensor (max sensor temp 60°C)	Temp Range Xp = 2K
RA2912	013G291200	Remote Sensor, 0-2m capillary tube	5-26°C
RA2916	013G291600	Remote Sensor, 0-2m capillary tube	5-22°C

RA2000 Remote Sensor Adjusters

Type	Code No	Sensor (max sensor temp 60°C)	Temp Range Xp = 2K
RA5062	013G506200	2m Capillary includes locking and limiting	8-28°C
RA5065	013G506500	5m Capillary includes locking and limiting	8-28°C
RA5068	013G506800	8m Capillary includes locking and limiting	8-28°C
RA5075	013G507500	15m Capillary includes locking and limiting	8-28°C

The range includes standard (5-26°C) and low (5-22°C) temperature range models. Both incorporate range locking and limiting features that allow the commissioning engineer to lock or limit the setting range of the sensor.

The RA2000 range also includes versions that take both sensing and temperature adjustment away from the valve. These remote temperature adjusters are ideal for use in situations where radiators are encased or where the demand is to locate the temperature adjustment at a position more convenient than on the radiator e.g. in residential accommodation for the elderly. The product is also an ideal solution for heated ceiling applications.

The remote temperature adjuster models comprise an actuator that is mounted on the valve and a thermostat unit which provides temperature sensing and adjustment. These are interconnected by an ultra-thin capillary tube. During installation the required length of capillary is pulled out and fixed to the wall using clips or staples.

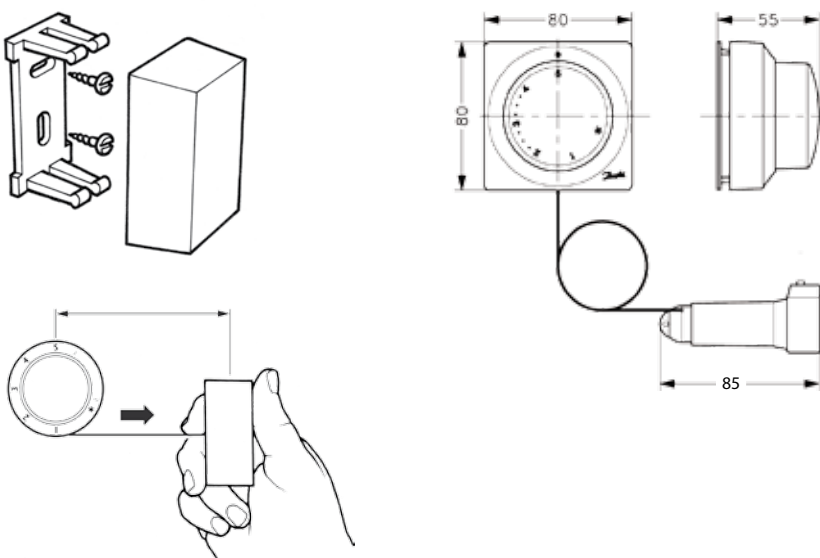

Lockshield Valves with Drain-Off

RLV



- Straight or angled versions
- Use in 1 or 2 pipe systems
- Maximum flow temperature 120°C
- Maximum working pressure 10 bar

The RLV range of lockshield valves match the finish and style of RA-G, RA-FN and RA-N valve bodies. They are available in vertical angle and straight pattern versions in 3/8", 1/2" and 3/4" sizes for screwed pipe-work and 15mm for copper pipe-work.

Adjustment of the valve is made using a 6mm Allen key. Once set, a screw-on brass cover conceals the valve setting mechanism.

In addition to providing a balancing and isolation function, RLV lockshield valves also incorporate a drain-down/filling feature. To utilise this feature a drain-off accessory is mounted to the valve in place of the decorative cap. The system can then be drained down or filled by connecting a hose to the drain down adaptor.

Pattern	Type	Code No	Connection Sizes	
			Pipe	Radiator
Vertical Angle	RLV 10	003L014100	3/8"	3/8"
	RLV 15	003L014300	1/2"	1/2"
	RLV 15	003L014315	15mm	1/2"
	RLV 15	003L182500	Press Fit	1/2"
	RLV 20	003L014500	3/4"	3/4"
Straight	RLV 10	003L014200	3/8"	3/8"
	RLV 15	003L014400	1/2"	1/2"
	RLV 15	003L014415	15mm	1/2"
	RLV 15	003L182400	Press Fit	1/2"
	RLV 20	003L014600	3/4"	3/4"

Drain-cock Adaptor and Compression Fittings for RLV Series Valves

Code No	Description
003L015200	Drain-cock adaptor for use with RLV models only, not RLV-S

Specification

Maximum working pressure	10 Bar
Maximum working temperature	120°C
Test pressure	16 Bar
Valve body finish	Nickel Plated
Gland seal type	Double O-ring
Supplied with LSV cap (nickel plated brass)	Yes
Supplied with wheel head cap	No

Dimensions

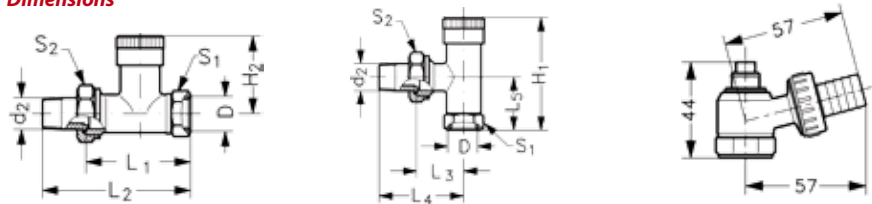

Type	D	d ₂	H ₁	H ₂	L ₁	L ₂	L ₃	L ₄	L ₅	S ₁	S ₂
RLV 10	R _p 3/8	R _p 3/8	55	40	49	75	26	52	22	22	27
RLV 15	R _p 1/2	R _p 1/2	59	40	51	80	29	58	27	27	30
RLV 20	R _p 3/4	R _p 3/4	62	42	59	91	34	66	30	32	37

Use of Drain Cock Adaptor

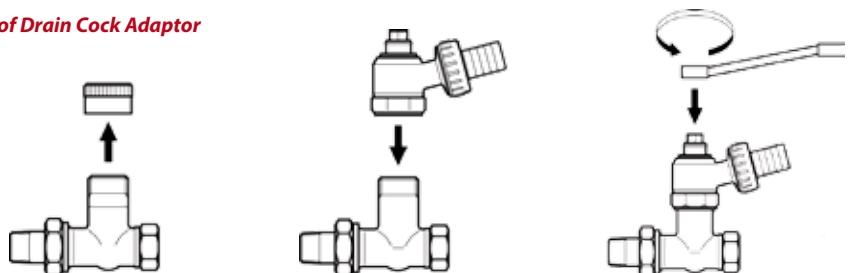

Lockshield Valves Without Drain-Off

RLV-S



Pattern	Type	Code No	Connection Sizes	
			Pipe	Radiator
Vertical Angle	RLV-S 10	003L012100	3/8"	3/8"
	RLV-S 15	003L012300	1/2"	1/2"
	RLV-S 15	003L012315	15mm	1/2"
	RLV-S 20	003L012500	3/4"	3/4"
Straight	RLV-S 10	003L012200	3/8"	3/8"
	RLV-S 15	003L012400	1/2"	1/2"
	RLV-S 15	003L012415	15mm	1/2"
	RLV-S 20	003L012600	3/4"	3/4"

- Straight or angled versions
- Use in 1 or 2-pipe systems
- Maximum flow temperature 120°C
- Maximum working pressure 10 bar

The RLV-S range of lockshield valves match the finish and style of RA-G, RA-FN and RA-N valve bodies. They are available in vertical angle and straight pattern versions in 3/8", 1/2" and 3/4" sizes for screwed pipe-work and 15mm for copper pipe-work.

Specification	
Maximum working pressure	10 Bar
Maximum working temperature	120°C
Test pressure	16 Bar
Valve body finish	Nickel Plated
Gland seal type	Double O-ring
Supplied with LSV cap (nickel plated brass)	Yes
Supplied with wheel head cap	No

Adjustment of the valve is made using a 6mm Allen key. Once set, a screw-on brass cover conceals the valve setting mechanism.

The RLV-S does not incorporate a drain down feature.

Dimensions

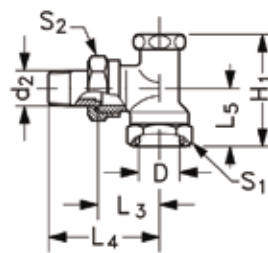
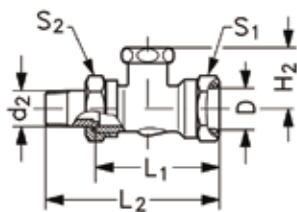

Type	D	d ₂	H ₁	H ₂	L ₁	L ₂	L ₃	L ₄	L ₅	S ₁	S ₂
RLV-S 10	G _p 3/8	R _p 3/8	42	26	51	75	27	51	23	22	27
RLV-S 15	G _p 1/2	R _p 1/2	52	28	53	80	30	57	27	27	30
RLV-S 20	G _p 3/4	R _p 3/4	52	28	61	92	34	65	30	32	37

H-Pieces with Drain Off

RLV-KD



- Lockshield valve function
- Straight or angled versions
- Use in 2-pipe systems
- Self sealing radiator connection
- Maximum flow temperature 120°C
- Maximum working pressure 10 bar

Some radiator manufacturers now produce radiators with integrated radiator thermostats. Generally the connections on such radiators are located on the bottom of the radiator spaced at an industry standard of 50mm.

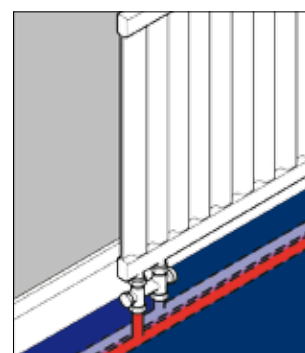
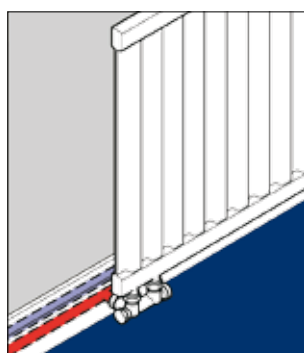

RLV-KD H-Pieces allow system pipe-work and radiators to be conveniently connected to copper, PEX or ALUPEX pipe systems. Radiator connections are normally either 1/2" internal or 3/4" external threads and versions of the RLV-KD are available for both standards.

RLV-KD H-Pieces incorporate a balancing feature and provide isolation of both flow and return connections essential for radiator removal. The valves are available for both bottom entry or rear entry pipe-work, see order table for details.

RLV-KD also provides a drain down/system filling feature by means of a drain down adaptor, see order table for details.

RLV-KD H-Pieces with drain facility ⁽¹⁾	
Code No	Description
003L024000	Bottom connection for use with radiators having 1/2" internal connections
003L024200	Back connection for use with radiators having 1/2" internal connections
003L024100	Bottom connection for use with radiators having 3/4" external connections
003L024300	Back connections for use with radiators having 3/4" external connections
Accessories for H-Pieces	
003L015200	Drain-cock adaptor for use with RLV-KD H-pieces

Please note: (1) order pipe fittings separately, see page 22

Dimensions

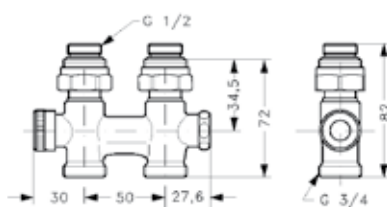

RLV-KD bottom connection, 1/2" internal connection

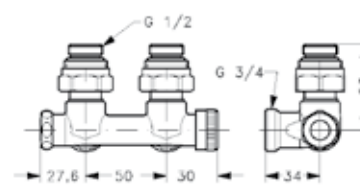

RLV-KD back connection, 1/2" internal connection

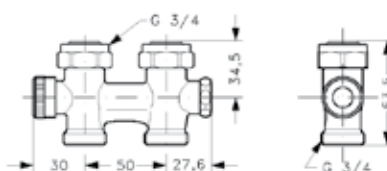

RLV-KD bottom connection, 3/4" internal connection

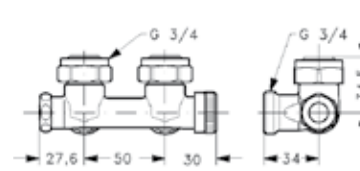

RLV-KD back connection, 3/4" internal connection

H-Pieces without Drain Off

RLV-KS

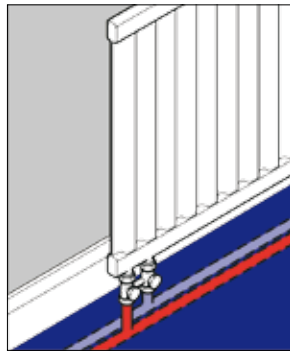
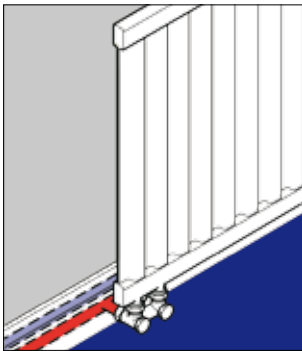

- Lockshield valve function
- Use in 2-pipe systems
- Straight or angled versions
- Self sealing radiator connection
- Maximum flow temperature 120°C
- Maximum working pressure 10 bar

RLV-KS H-Pieces allow system radiators with 50mm centre connections to be conveniently connected to copper, PEX or ALUPEX pipe systems. Radiator connections are normally either 1/2" internal or 3/4" external threads and versions of the RLV-KSD are available for both standards.

RLV-KS H-Pieces without drain facility ⁽¹⁾	
Code No	Description
003L022000	Bottom connection for use with radiators having 1/2" internal connections
003L022200	Back connection for use with radiators having 1/2" internal connections
003L022100	Bottom connection for use with radiators having 3/4" external connections
003L022300	Back connections for use with radiators having 3/4" external connections

Please note: (1) order pipe fittings separately, see page 22

RLV-KS H-Pieces incorporate a balancing feature and provide isolation of both flow and return connections essential for radiator removal. The valves are available for both bottom entry or rear entry pipe-work, see order table for details.

RLV-KS does not provide a drain down facility.

Dimensions

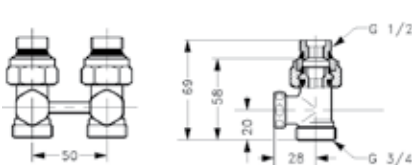

RLV-KS bottom connection, 1/2" internal connection

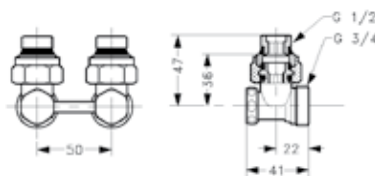

RLV-KS back connection, 1/2" internal connection

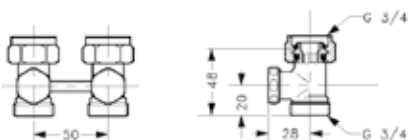

RLV-KS bottom connection, 3/4" internal connection

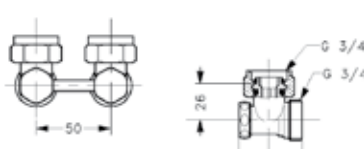

RLV-KS back connection, 3/4" internal connection

Spare Parts and Accessories

Gland Seals, Sensors and Adapters



Gland Seal

- Just two gland seals cover the whole range of Danfoss valves
- Can be replaced without draining down the system

Replacement Sensor

- Allows easy up-grade of old valves without the need to drain down
- Versions available for RAVL and RAV valve bodies
- Available in built-in and remote sensor versions

Gland Seals

All gland seals in Danfoss radiator thermostats are designed to provide a long and trouble free in-service life. However, periodically it may be necessary to replace seals should failure occur.

All valves produced by Danfoss since early 1960s incorporate gland seal assemblies which can be replaced without draining down the system.

Valve Adaptor

Adaptors to convert RA2000 remote temperature adjusters for use with RAV and RAVL bodies already installed.

Manual Positive Shut-Off Dial

The RA manual positive shut-off dial fits onto all valve bodies in the RA Series and can be used for manual opening and closing of the valve.

Replacement Sensors

Replacement sensors incorporate RA2000 sensor technology and design, and provide a simple and straight forward way to upgrade older radiator thermostats without the need to drain down the system.

Gland Seals					
013G029000	Gland Seal Assembly for RA-FS, RA-FR, RA-FN, RA-N, RA-DV and RA-G Valves				
013U007000	Gland Seal Assembly for RAV and RAVL Valves				
Accessories for RA2000 Sensors and Valves					
013G123200	Anti-Theft for Sensors (50 pieces)				
013G123700	Threaded Range Limiting pins (30 pieces)				
013G123300	RA2020 Scale Cover (20 pieces)				
013G123600	Toolkit, comprising Allen Key and Locking Pin Tool				
013G123000	Accessory Bag for RA2000 Remote Sensor Base, Fixing Screw and Capillary Caps				
Accessories for RA2000 Remote Adjusters					
013G519300	Adaptor for RA5062, 5065 and 5068 for RAV Valves				
013G519200	Adaptor for RA5062, 5065 and 5068 for RAVL Valves				
Accessories for RA-FS, RA-FN, RA-N & RA-G Valves					
Code No	Description	RA-FS	RA-FN	RA-N	RA-G
013G500100	Blanking Cap for Valve Outlet	•			
013G027500	Spare Protective Cap	•	•	•	•
013G500200	RA Hand Wheel	•	•	•	•

Selecting a suitable replacement sensor

RAVL thermostats are replaced by RA/VL

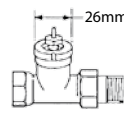

RAV thermostats are replaced by RA/V

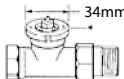

RA2000 Replacement Sensors and Gland Seals

Existing Valve Body Dimensions	Existing Valve Body Type	Replacement Sensor - please note: the Code No's have changed				
		New Code No	Old Code No	Sensor Type	Description	Temp Range (Xp = 2k)
	RAVL	013G295000	013G221000	RA/VL	Built-In Sensor	5 - 26°C
		013G295200	013G221200	RA/VL	Remote Sensor 2m Capillary	
	RAV	013G296000	013G231000	RA/V	Built-In Sensor	5 - 26°C
		013G296200	013G231200	RA/V	Remote Sensor 2m Capillary	
	RA-FN RA-G RA-N	Refer to RA2000 Sensors on p. 16-19				

Compression Fittings For Copper, PEX and ALUPEX Pipe



For Valves with Female Threaded Connections

Compression Fittings for:	RA-FN, RA-N, RA-DV Radiator Thermostat Valve Bodies, RLV and RLV-S Lockshield Valve Bodies
Pipe Type:	Copper
013G410000	3/8" x 10mm
013G410200	3/8" x 12mm
013G411000	1/2" x 10mm
013G411200	1/2" x 12mm
013G411500	1/2" x 15mm
Pipe Type:	PEX
013G414400	1/2" x 14 x 2.0mm
013G414700	1/2" x 15 x 2.5mm
013G415600	3/4" x 16 x 2.0mm
Pipe Type:	ALUPEX
013G417400	1/2" x 14 x 2mm

Please note: Copper pipe must be in accordance with BS2871 part 1/BSEN1057. It is recommended to use supporting bushes with soft copper pipes. PEX pipe must be in accordance with DIN16892/16893 or BS7291 part 1:1990 or part 3:1990. Maximum operating pressure and temperature are given by the pipe manufacturer. However, 6 bar and 95°C must not be exceeded.

Design: For use with valves having a female threaded connection. Fitting comprises olive and externally threaded compression nut, dimension of female thread is included in the description. For PEX and ALUPEX a pipe support insert is also included.

For Valves with Male Threaded Connections

Compression Fittings for:	RA-KE, RA-KEW and FHF-F
Pipe Type:	Copper
013G412000	3/4" x 10mm
013G412200	3/4" x 12mm
013G412500	3/4" x 15mm
Pipe Type:	PEX
013G415500	3/4" x 15mm x 2.5mm
013G416300	3/4" x 16mm x 2.2mm
013G415900	3/4" x 18mm x 2.5 mm
013G416100	3/4" x 20mm x 2.5mm
Pipe Type:	ALUPEX
013G418400	3/4" x 14mm x 2.0mm
013G418600	3/4" x 16mm x 2.0mm
013G418800	3/4" x 18mm x 2.0mm
013G419000	3/4" x 20mm x 2.0mm

Please note: Copper pipe must be in accordance with BS2871 part 1/BSEN1057. It is recommended to use supporting bushes with soft copper pipes. PEX pipe must be in accordance with DIN16892/16893 or BS7291 part 1:1990 or part 3:1990. Maximum operating pressure and temperature are given by the pipe manufacturer. However, 6 bar and 95°C must not be exceeded.

Design: For use with valves having a 3/4" male threaded connection. Fitting comprises olive and internally threaded compression nut. For PEX and ALUPEX a pipe support insert is also included.

Valve Capacities

Proportional temperature controls try to maintain equilibrium between heat loss and heat input. They react in proportion to any deviation from a set temperature level, until heat input is either completely shut off or is at its maximum. The temperature levels at which this occurs are presettable, and the band between the two levels, measured in K (degrees C), is the proportional band.

RA-N valves with pre-setting

The pre-setting function on RA-N valves limits the maximum flow through the valve, regardless of the radiator thermostat's temperature setting. An adjustable aperture integrated into the valve creates this limitation.

Correctly sized, the maximum flow limitation ensures that each radiator in a heating system - regardless of size - will get exactly the flow necessary to heat up a room - no more, no less. By installing RA-N pre-setting valves the heating system will always be correctly balanced.

The unique pre-setting function makes it possible, as early as the planning stage, to accurately calculate each valve's pre-setting value, thus avoiding the need for temperature drop based commissioning of lockshield valves on site.

No tools are necessary when adjusting the pre-setting. With the sensor mounted it is not possible to get access to the pre-setting function.

RA-N 10 and RA-FN 10 (All models)

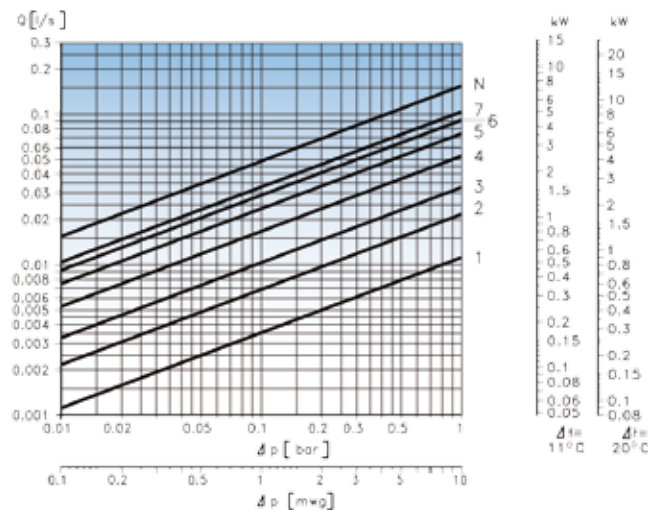

The pre-setting values 7 to 1 only apply for the pre-setting valve RA-N.

RA-N 15 and RA-FN 15 (All models)

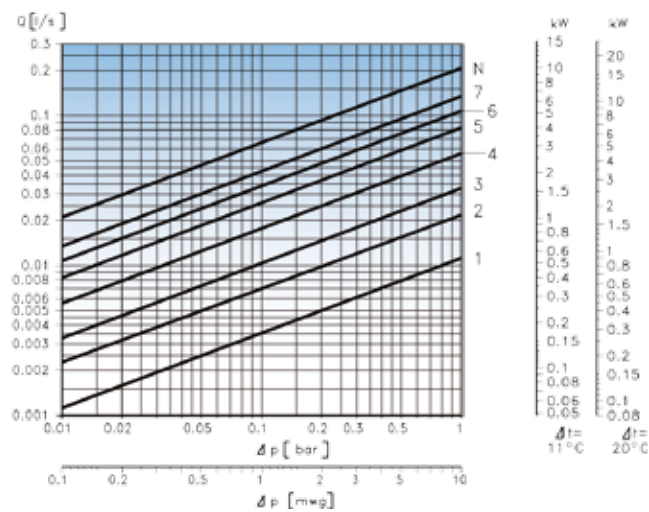

The pre-setting values 7 to 1 only apply for the pre-setting valve RA-N.

RA-N 20/25 and RA-FN 20/25 (Straight and Vertical Angle)

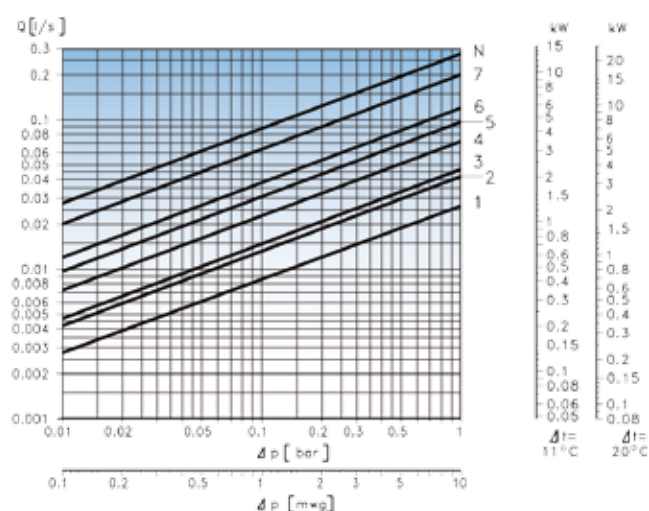

The pre-setting values 7 to 1 only apply for the pre-setting valve RA-N.

RA-N 20 and RA-FN 20 (Horizontal Angle)

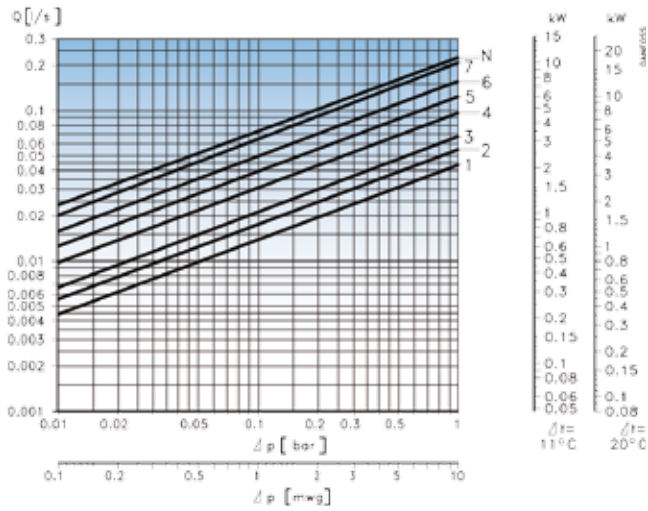

The pre-setting values 7 to 1 only apply for the pre-setting valve RA-N.

When a room needs to be redecorated, at some later date, it is possible to close the valves and remove the radiator in the normal way.

With the RA-N pre-setting valve it is easy to return to the optimal balance in the heating system, as there is no need to remember any setting on the lockshield valve. Just remount the radiator and open the lockshield valve fully. The pre-setting of the RA-N valve stays correctly adjusted during the whole process.

The capacities shown here are all with a proportional band of 2K and an RA2000 sensor. When using remote temperature adjusters the capacity values must be reduced by 40%.

RA-G (All models)

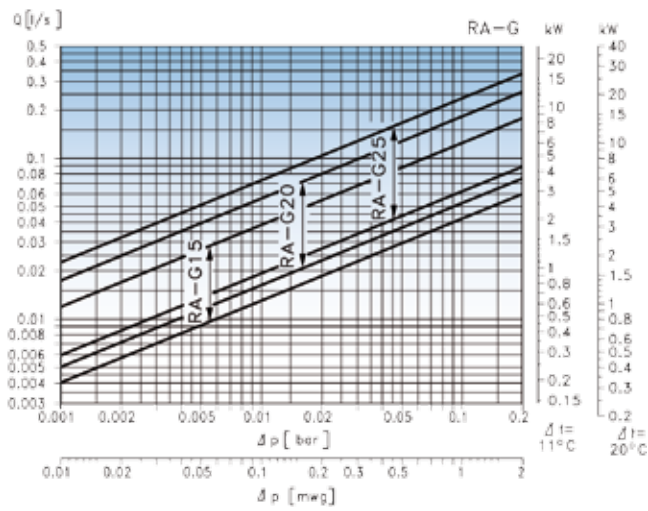

Please note:

As with any device which imposes a pressure drop in the system, noise may occur under certain flow/pressure conditions. To ensure quiet operation, maximum pressure drop should not exceed 0.3 bar.

ENGINEERING
TOMORROW

Danfoss

Danfoss Ltd

Amphill Road, Bedford, MK42 9ER
Tel: 01234 364621
Fax: 01234 219705
Email: ukheating@danfoss.com
Website: www.heating.danfoss.co.uk

Danfoss can accept no responsibility for possible errors in catalogues, brochures, and other printed material. Danfoss reserves the right to alter its products without notice. This also applies to products already on order provided that such alterations can be made without subsequent changes being necessary in specifications already agreed. All trademarks in this material are property of the respective companies. Danfoss and the Danfoss logotype are trademarks of Danfoss A/S. All rights reserved.
