

TECHNICAL DATA SHEET

PRODUCT

1000 QUAD PANEL KIT 1

PRODUCT CODE

EXH0389

SPECIFICATION

- **PANEL FINISH :**
- **PRODUCT TYPE :**
- **PANEL HEIGHT :**
- **AVAILABLE FOR SIZES :**
- **GUARANTEE PERIOD :**
- **FITTING :**

ABS ACRYLIC
SANITARY WARE

95mm

800 QUAD LH/RH, 900 QUAD LH/RH, 1000 QUAD LH/RH

12 MONTHS

INSTRUCTIONS INCLUDED WITH TRAY -
TRIM TO TRAY SIZE, INDICATED ON PANEL

KIT VIEW

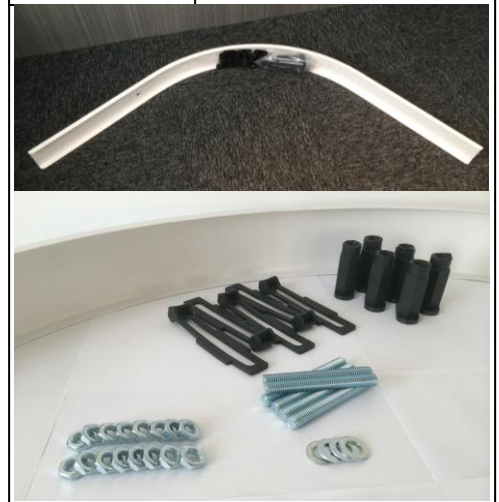

- **DIMENSIONS OF PANEL**

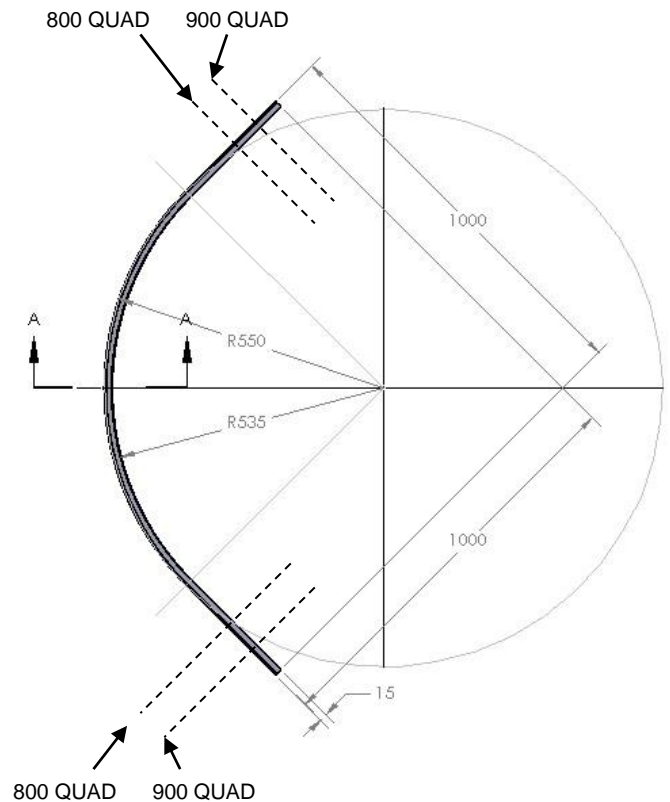
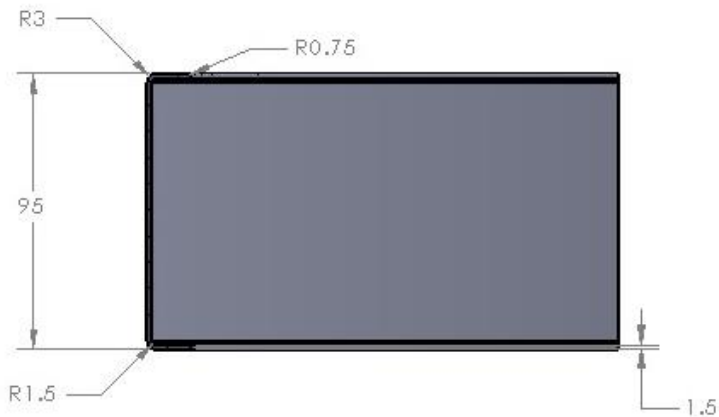

INCLUDED IN KIT:

- 1 x QUAD PANEL
- 6 x LEGS
- 5 x PANEL HOLDERS
- 6 x M12 SCREWED BARS
- 16 x M12 NUTS
- 4 x Washers

