

STUART

Installation, Operation & Maintenance Instructions

Please leave this instruction booklet with the home owner as it contains important guarantee, maintenance and safety information



Read this manual carefully before commencing installation.

This manual covers the following products:

PH 35 ES B
Pt. No. 46523

PH 45 ES B
Pt. No. 46524

50 Hz



PRODUCT DESCRIPTION

Electric motor driven pump complete with flow switch, pressure switch, pressure vessel and electronic control.

APPLICATION

The Pressure Control range is designed for pressure boosting applications in vented stored hot or cold, clean fresh water systems, where under gravity, no flow is available. Other clean non aggressive, non explosive liquids with similar characteristics to water may be pumped, consult Stuart Turner for such applications.

STORAGE

If this product is not to be installed immediately on receipt, ensure that it is stored in a dry, frost and vibration free location in its original packaging.

CONTENTS

	Page
Checklist5
Pre-Installation Assembly6
Important Facts – read before commencing installation8
Location9
Pump Connections11
Electrical Installation12
Commissioning14
Maintenance16
Technical Specification17
Trouble Shooting19
Guarantee22

WARNINGS:



- This pump set must not be used for any other application without the written consent of Stuart Turner Limited and in particular, must not be connected directly to the mains water supply.
- This appliance can be used by children aged from 8 years and above and persons with reduced physical, sensory or mental capabilities or lack of experience and knowledge if they have been given supervision or instruction concerning use of the appliance in a safe way and understand the hazards involved.
- Children shall not play with the appliance.
- This product should not be used for the supply of water to more than one dwelling (house, apartment, flat).
- Cleaning and user maintenance shall not be made by children without supervision.
- Maximum head (closed valve) PH 35 ES B-30 metres, PH 45 ES B-41 metres.
- The motor casing can become very hot under normal operating conditions. Care must be taken to ensure it cannot be touched during operation.



- The electrical installation must be carried out in accordance with the current national electrical regulations.
- The electrical installation must be installed by a qualified person.
- In the interests of electrical safety a 30 mA residual current device (R.C.D. not supplied) should be installed in the supply circuit. This may be part of a consumer unit or a separate unit.
- Before starting work on the electrical supply ensure power supply is isolated.



- **DO NOT allow the supply cord to contact hot surfaces, including the motor shell, pump body or pipework. The cord should be safely routed and secured by cable clips.**
- **This appliance must be earthed via the supply cord, which must be correctly connected to the earth point located in the terminal box.**
- **The supply cord and internal wiring within the terminal box are routed and secured to ensure compliance with the electrical standard EN 60335-1. It is essential that prior to any disturbance of this internal wiring, all cable routing and securing details are carefully noted to ensure re-assembly to the same factory pattern is always maintained.**
- **If the supply cord is to be changed or is damaged, it must be replaced with a special cord assembly available from Stuart Turner or one of their approved repairers.**

Please read installation details carefully as they are intended to ensure this product provides long, trouble free service. Failure to install the unit in accordance with the installation instructions will lead to invalidation of the warranty.

CHECKLIST

IMPORTANT: With the pump removed from its packaging check for any damage prior to installation. If any damage is found contact Stuart Turner Ltd within 24 hours of receipt.

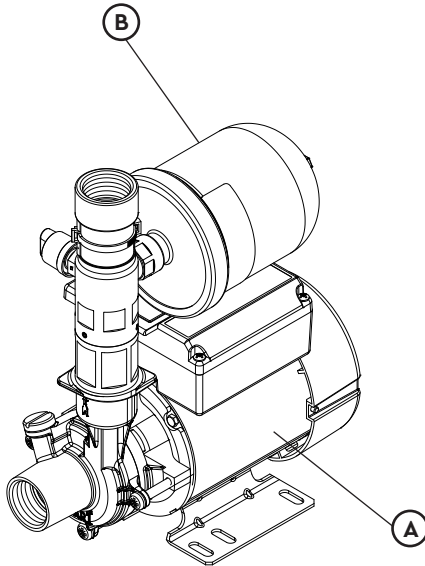

Fig. 1

Note: This image is for reference only

Item	Description	Qty	Item	Description	Qty
(A)	Pump	1	(B)	Pressure Vessel & 'O'-ring	1

Your product may vary slightly from the picture above.

PRE-INSTALLATION ASSEMBLY

Pressure Check and Assembly of Pressure Vessel

- a) Certain models are supplied in two parts, the main pump and the pressure vessel. The pressure vessel is pre-charged with air at the factory (see table below). This pressure should be checked at the Schrader valve (Fig. 2) using a tyre pressure gauge and adjusted if necessary using a car or bicycle pump prior to installation.
- b) To assemble the vessel (when applicable), remove protective plastic cap from fitting point. Ensure that the 'O'-ring is present and correctly fitted in the location groove at the bottom of the fitting point. Screw the pressure vessel clockwise into the fitting point until hand tight to achieve a water tight connection.

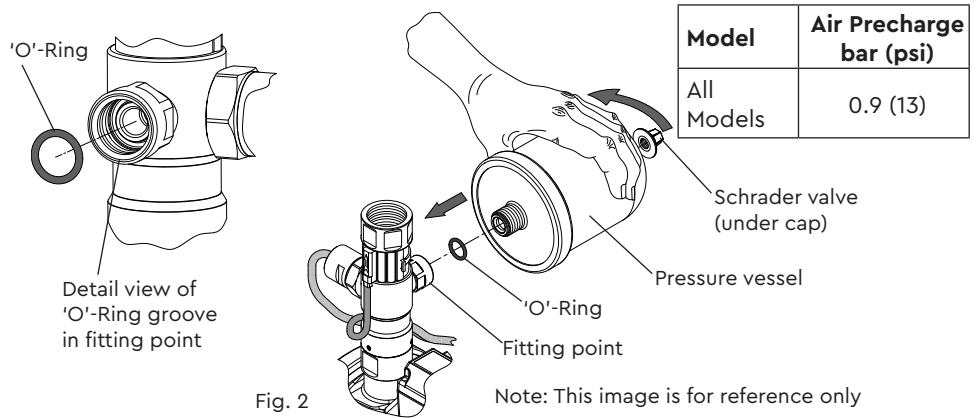

NOTE: Do not over tighten pressure vessel.

Re-positioning of Pressure Vessel

The pressure vessel can be rotated to alternative positions (Fig. 4) in the event of the factory fitted position being unsuitable for a specific installation.

- a) Remove pressure vessel by unscrewing anti-clockwise.
- b) Using a 2 mm allen key, carefully loosen all three retaining grub screws by two turns (Fig. 3).
- c) Warning – Care must be taken when re-positioning the pressure vessel to ensure no strain is placed upon the pressure switch or reed switch cables. The flow switch assembly can now be carefully rotated to an alternative position (Fig. 4).
- d) Ensure all three grub screws are re-tightened securely to a torque of 2.2 Nm (1.62 lbf feet).
- e) Re-fit the pressure vessel ensuring the 'O'-ring seal is in place (see pre-installation section).

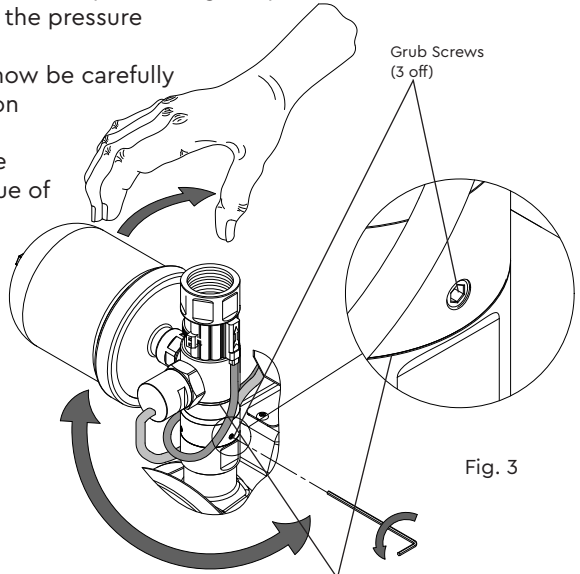

Area for alternative fitting positions

Fig. 4

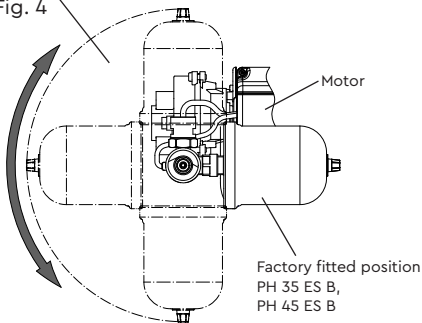

Outlet Tower can be swivelled at this joint line after loosening the 3 equi-spaced grub screws

Note: These images are for reference only

1 IMPORTANT FACTS: READ BEFORE COMMENCING PUMP INSTALLATION

A Water storage capacity.

- 1.11 The hot and cold water storage capacity must be sufficient to meet the flow rates required by the pumped equipment and any other water using fittings and appliances, which may be operated simultaneously.
- 1.12 Ensure the pump is primed as described in the priming section before starting, damage to the shaft seal will result otherwise. See Section 5 – Commissioning.

B Water temperature

The water entering the pump must be controlled as follows:

- 1.13 The maximum allowable water temperature is 65 °C.
- 1.14 The minimum allowable water temperature is 4 °C.
- 1.15 **DO NOT** fit a pump if the hot water is heated via a method whereby the water temperature cannot be controlled, such as solar or solid fuel you must consult the TechAssist team on +44 (0) 800 31 969 80.

C Pipework – General

- 1.16 **Secure pipework:** Ensure pipework to and from pump is independently supported & clipped to prevent forces being transferred to inlet and outlet branches of pump.
- 1.17 **Flux:** Solder joints must be completed and flux residues removed prior to pump installation (**flux damage will void any warranty**).
- 1.18 **Pipework design:** Care should be taken in the design of pipework runs to minimize the risk of air locks e.g. use drawn bends rather than 90° bends.



- 1.19 **DO NOT** introduce solder flux to pump or pump parts manufactured from plastic.

- 1.20 **DO NOT** allow contact with oil or cellulose based paints, paint thinners or strippers, acid based descalents or aggressive cleaning agents.



- 1.21 **DO NOT** install a non-return valve, or devices which contain non-return valves, in the suction (inlet) pipework to the pump. The pump must be free to vent to the supply tank at all times.

- 1.22 **DO NOT** bend flexible hoses (not supplied but available from Stuart Turner) beyond 30°. They must be installed as straight as possible.

- 1.23 **DO NOT** connect this pump to the mains water supply.

D Plumbing Installation Regulations

- 1.24 The plumbing installation must comply with the current water and building regulations.
- 1.25 The plumbing installation must be installed by a qualified person.

E Pressure vessel

- 1.26 Pressure vessel is charged at the factory see Pre-Installation Assembly on page 5.

2 LOCATION – GENERAL



- 2.11 **Access:** For emergencies and maintenance the pump must be easily accessible.
- 2.12 **Protection:** The pump must be located in a dry position, frost free and protected from freezing, particularly when installed in a loft (not recommended).
- 2.13 **Ventilation:** Ensure an adequate air flow to cool the pump. Separate the pump from other appliances that generate heat. An 80 mm (3 ") air gap must be maintained around the pump.
- 2.14 **Safety:** The motor casing can become very hot under normal operating conditions. Care must be taken to ensure it cannot be touched during operation.
- 2.15 **Water retention:** Site the pump in a location where in the unlikely event of a water leak, any spillage is contained or routed to avoid electrics or areas sensitive to water damage.
- 2.16 **Static inlet pressure:** Before deciding where to position the unit, check to ensure the static inlet and outlet heads of water above the pump (Fig. 5), does not exceed the maximum permitted limits.
- 2.17 **Pump position:** The pump must be positioned as close to the water source as possible. Ensure the pump is mounted in a position that allows easy access to the box terminal if required.
- 2.18 **Ambient temperature:** The pump must be sited in a location where the maximum ambient temperature does not exceed 40 °C.
- 2.19 **Pipework:** For optimum performance pipework **MUST** be 22 mm. Pipework should only reduce to 15 mm when entering terminal fitting.
- 2.20 **Static outlet pressure:** The static outlet head must also be within the maximum requirement (Fig. 6).
- 2.21 **Noise:** Care must be taken when mounting the pump that any noise is not amplified through loose panels or pipework. **Do not screw down the pump.**
- 2.22 **Direction of flow:** Ensure the water flow is in the direction of the arrow that is marked on the flow switch reed clamp (vertically upwards).
- 2.23 **Flexible hoses:** Use only Stuart Turner hoses (not supplied), if used ensure they do not come into contact with solder flux.
- 2.24 **Isolating valves:** Separate isolating valves (non restrictive) must be fitted to allow easy pump service.

2.25 Pump Mounted Below Liquid Source (Flooded Suction Installation):

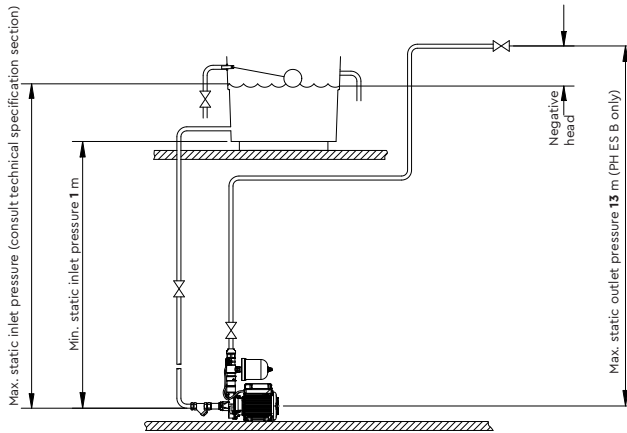

Diagram showing typical Pressure Control installation with flooded suction.

Fig. 5

2.26 Before deciding where to locate the unit, check to ensure the static inlet head (Fig. 5) meets the minimum requirement of 1 metre and does not exceed the maximum given in the limits of application section.

2.27 The static outlet head (Fig. 5) must also be within the maximum requirement of 13 metres for all models.

2.28 Pump Mounted Above Liquid Source (Suction Lift Installation):

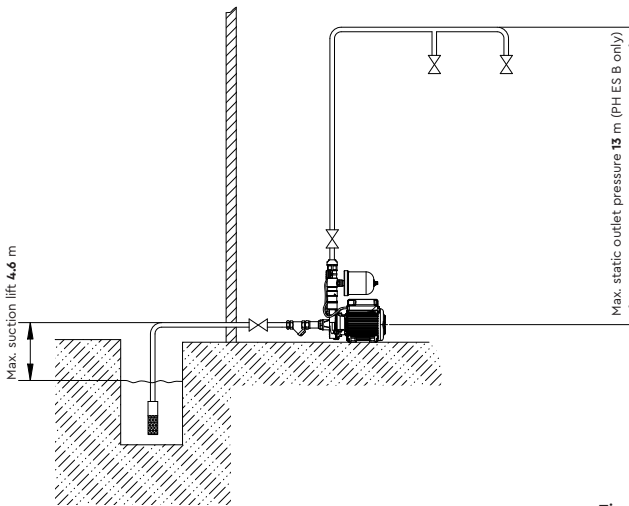

Diagram showing typical Pressure Control installation with suction lift.

Fig. 6

2.29 The pumps can be used in a suction lift installation providing the height of lift is within the limits specified in the limits of application section and the liquid to be pumped is cold water (for applications other than cold water contact Stuart Turner).

Cont ...

- 2.30 Before deciding where to locate the unit, check to ensure the static outlet head (Fig. 8) does not exceed the maximum requirements of 13 metres for all models.
- 2.31 A footvalve and strainer must always be used and the suction pipework size must match the pump.
- 2.32 Lay the suction piping over the shortest possible distance and ensure there is a constant rise from the liquid source to the pump. Any high spots will cause air pockets to form, reducing system efficiency.
- 2.33 Ensure all joints in suction pipework are completely airtight. Failure to comply will result in loss of prime.
- 2.34 The intake of the footvalve/strainer should be positioned such that it cannot be blocked with debris or silt that are frequently found in the bottom of sumps and wells.
- 2.35 When a footvalve is installed in the suction pipework, it is recommended that suitable pressure relief valve be fitted in the discharge (outlet) pipework from the pump.

3 PUMP CONNECTIONS

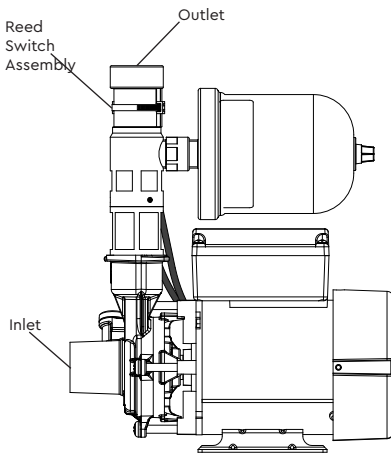

Fig. 7

Note: This image is for reference only

Model	Inlet (Pump)	Outlet	Fig. No.
PH 35 ES B	G 1 Female	G 1 Female	7
PH 45 ES B	G 1 Female	G 1 Female	7

4 ELECTRICAL INSTALLATION



- 4.11 **Regulations:** The electrical installation must be carried out in accordance with the current national electrical regulations and installed by a qualified person.
- 4.12 **Safety:** In the interests of electrical safety a 30 mA residual current device (**R.C.D. not supplied**) should be installed in the supply circuit. This may be part of a consumer unit or a separate unit.
- 4.13 Before starting work on the electrical supply ensure power supply is isolated.
- 4.14 The motor and wiring must not be exposed to water.
- 4.15 **DO NOT** allow the supply cord to contact hot surfaces, including the motor shell, pump body or pipework. The cord should be safely routed and secured by cable clips.
- 4.16 **Adjacent pipes:** Adjacent suction and delivery pipes should be fitted with earthing clamps in accordance with current regulations (Fig. 8).

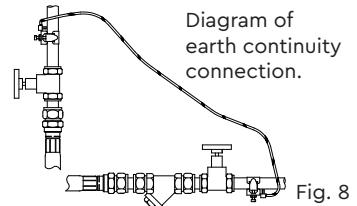

- 4.17 **Earthing:** This appliance must be earthed via the supply cord, which must be correctly connected to the earth point located in the terminal box.
- 4.18 **Pipework:** Copper or metallic pipework must have supplementary earth bonding where the continuity has been broken by flexible hoses or plastic components.
- 4.19 **Additional earthing:** Certain installations may require additional earthing arrangements such as equipotential bonding. Reference should be made to the relevant regulations concerning this subject to ensure compliance.
- 4.20 **Connections:** The pump must be permanently connected to the fixed wiring of the mains supply using the factory fitted supply cord, via a double pole switched fused spur off the ring main and **NOT** connected to the boiler or the immersion heater circuits.
- 4.21 **Wiring Of Connection Unit:**
The wires in the mains lead (supply cord) are coloured in accordance with the following code:

Green and Yellow: Earth
Blue: Neutral
Brown: Live

As the colours of the wires in the mains lead of this appliance may not correspond with the coloured markings identifying the terminals in your connection unit proceed as follows:

- The wire which is coloured green and yellow must be connected to the terminal in the connection unit which is marked with the letter E or by the earth symbol: ⊕ or coloured green or green and yellow.
- The wire which is coloured blue must be connected to the terminal which is marked with the letter N or coloured black.
- The wire which is coloured brown must be connected to the terminal which is marked with the letter L or coloured red.

4.22 Wiring Diagram:

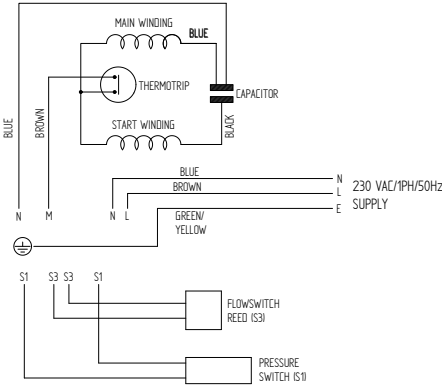

PH 35 ES B
Fig. 9

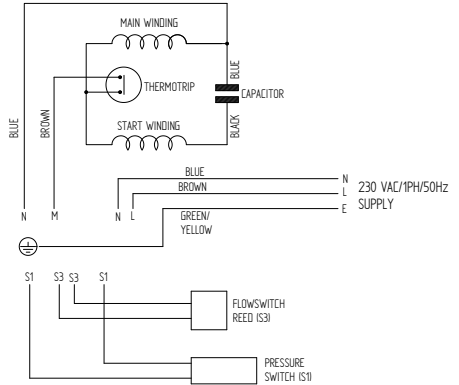

PH 45 ES B
Fig. 10

4.23 **Fuses:** The following fuse size should be used with the appropriate pump.

Model	Fuse Size (AMPS)
All models	5

4.24 Supply Cord Replacement:

If the supply cord needs to be replaced, cord selection should be chosen in accordance with the current involved, surrounding conditions and recommended fuse size. For information on cable fitting and connection, consult the wiring diagram and cable gland fitting instructions.

4.25 Cable Gland Fitting Instructions:

To enable correct assembly of the cable gland, the 'O'-ring (Fig. 11 item 1) must be placed over the cable before the clamping insert (Fig. 11 item 2) can be tightened as shown.

Note: Cable diameter range:- 6.5 mm to 9.5 mm.

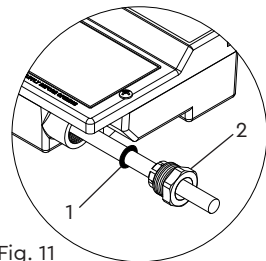

Fig. 11

4.26 Supply Cord Extension:

The pumps are fitted with a supply cord to the following specifications:-

All models:- HO5VV-F3 G 0.75 mm² – 6 Amp rating.

If the supply cord is to be extended, a cord of the same specification should be used. Any connections or junction boxes used should be specifically suited for the application and installed in accordance with the manufacturers instructions.

5 COMMISSIONING



5.11 **System Flushing:** This pump-set incorporates plastic components that must not come into contact with solder flux, acid-based descalents or aggressive cleaning agents. The pipework system should be flushed out prior to the pump being connected to ensure any contaminants/chemical residues and foreign bodies are removed from elsewhere in the system.

5.12 **Liquid Supply:** Always ensure that liquid storage capacity is adequate to meet the demand. Ensure the pump chamber is full of liquid before starting the pump. Failure to do this could result in seal damage. To ensure dry running does not occur the pumps must be primed as described in priming section.

Do not run pump dry.

5.13 Ensure electrical supply is compatible with the details that are stated on the pump rating plate. (The wrong voltage or frequency can be dangerous and may damage the pump.)

5.14 Priming:

a) Flooded suction installation

The pump must be primed (filled with liquid) before starting. Turn on liquid supply, prime and vent the pump by unscrewing the priming plug (Fig. 12) slowly until all air escapes and liquid emerges. Re-tighten plug.

b) Suction lift installation

A footvalve and strainer must be fitted to the end of the inlet pipework. Prime the suction pipework by filling before connecting to the pump. Prime the pump by filling via the priming plug (Fig. 12).

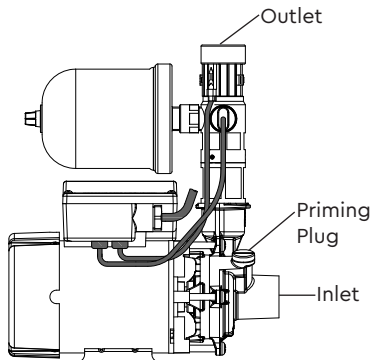

PH 35 ES B,
PH 45 ES B
Fig. 12

Note: This image is for reference only

5.15 **Starting The Pump:**

- a) Ensure all outlets are closed, turn power supply 'on' – pump will start, pressurise the system then stop.
- b) Open and close all outlets in turn associated with the pump, allowing liquid to flow from each outlet until all air is purged. As each outlet is opened and closed, the pump will start and stop respectively.
Note: After closing the outlet there will be a small time delay before the pump stops, which is normal.
- c) Any tap or control valve within the system when opened and closed will now turn the pump on/off. Providing this is the case the system is now operating correctly.
- d) Carefully check pump and pipework for leaks whilst pump running and stationary before leaving the installation unattended.

5.16 **For further technical support:** Phone the Stuart Turner TechAssist team on +44 (0) 800 31 969 80. Our staff are trained to help and advise you over the phone.

Note: When pumps are installed in another manufacturers original equipment, please contact the manufacturer for advice.

6 MAINTENANCE

- 6.11 Disconnect electrical supply before working on pump.
- 6.12 Turn off liquid supplies to the pump and release pressure by opening liquid outlets before attempting maintenance.
- 6.13 Inlet strainers and footvalve strainers when fitted may require periodical cleaning. The frequency of this operation is dependent upon installation conditions.
- 6.14 **Water scale:** As water is heated scale deposits are released in areas of hard water, scale can cause the mechanical seal to stick if left without use for long periods. We recommend the pump is run for at least 5 minutes every four weeks to "exercise" all working parts. Run on cool water.
- 6.15 After maintenance is completed, refer to the starting and commissioning sections for instructions on re-starting pump.
- 6.16 No other routine maintenance is required.
- 6.17 **Cleaners, disinfectants and descalents:**



Acid based descalents and aggressive cleaning agents must not come into contact with the pump. The pump must be removed from the system prior to the use of these products. The system should be flushed to remove all chemicals before the pump is re-connected.

If in any doubt as to the suitability of the chemical solutions, please contact our TechAssist helpline on +44 (0) 800 31 969 80.

7 TECHNICAL SPECIFICATION

Pump Model		PH 35 ES B 50 Hz 46523	PH 45 ES B 50 Hz 46524
General	Guarantee	2 years	
	WRAS approval	Approved materials	
	Approvals	CE	
Features	Pump type	Peripheral	
	Pump control	Pressure/flow switch	
	Anti-vibration feet	✓	✓
	Run on Timer	3 sec	3 sec
	Dry run protection	✓	✓
	Priming vent plug	✓	✓
	Typical noise	61 dB(A)	64 dB(A)
Materials	Pump body	Brass	
	Impeller	Brass	
	Mechanical seal	EPDM / PTFE /Al. Oxide	
Performance	Maximum head – closed valve	3.0 bar (30 metres)	4.1 bar (41 metres)
	Performance @ 9 l/min	2.0 bar (20 metres)	3.2 bar (32 metres)
	Performance @ 18 l/min	1.2 bar (12 metres)	2.2 bar (22 metres)
	Maximum flow	33 l/min	42 l/min
	Minimum static inlet pressure	0.1 bar (1 metre)	
	Maximum static inlet pressure	1.4 bar (14 metres)	
	Maximum static outlet pressure	1.3 bar (13 metres)	
	Maximum working pressure*	600 kPa (6 bar)	
	Maximum ambient air temperature	40 °C	
	Min / Max water temperature**	Min 4 °C / Max 65 °C	
	Pressure vessel air pre-charge	0.9 bar (13 psi)	
Maximum suction lift***	4.6 metres		
Connections	Pump connections	G 1 female	
Motor	Type	Induction, auto-reset thermal trip	
	Duty rating	Continuous (S1) @ 5 l/min and above	
Electrical	Power supply (Vac/Ph/Hz)	230 V a.c. / 1 / 50 Hz	
	Power consumption – P1	450 Watts	665 Watts
	Current – full load	1.95 Amps	2.9 Amps
	Fuse rating	5 Amps	
	Power cable length	1.5 metres (pre-wired)	
Physical	Enclosure protection	IP44	
	Length	255 mm	257 mm
	Width	133.5 mm	
	Height – excluding hoses	292 mm	
	Weight – including fittings	6.0 Kg	7.5 Kg

Stuart Turner reserve the right to amend the specification in line with its policy of continuous development of its products.

*Note: The maximum pressure that can be applied to the pump under any installation conditions.

Cont ...

- **Note: A stored water temperature of 60 °C is considered sufficient to meet all normal requirements and will minimize deposition of scale in hard water areas.
- ***Note: A suction lift of up to 4.6 metres can be achieved if a footvalve and strainer is used.
- 7.11 **Noise:** The equivalent continuous A-weighted sound pressure level at a distance of 1 metre from the pump does not exceed 70 dB(A).

8 TROUBLE SHOOTING GUIDE

Symptoms	Probable Cause	Recommended Action
Pump will not start.	<p>Electrical supply.</p> <p>Pump Jammed.</p> <p>Damaged pressure switch.</p> <p>Recommended static inlet/outlet heads exceeded.</p> <p>Internal motor thermotrip activated.</p>	<p>Check power supply. Check fuse (see fuse section). Check circuit breaker is set. Check wiring connections.</p> <p>If motor 'Buzzes' switch off power and contact Stuart Turner.</p> <p>Turn off power. Release system water pressure. Turn on power, pump should start. If NOT contact Stuart Turner.</p> <p>Re-position pump (see pump location section).</p> <p>Wait for thermotrip to auto-reset and check that duty point and run time is within specification (see technical specification).</p>
Reduced/intermittent flow.	<p>Incorrect or no anti-aeration flange fitted</p> <p>Incorrect pipe sizes.</p> <p>Blocked inlet filters.</p> <p>Hot water temperature set too high.</p> <p>Blocked shower head spray plate</p>	<p>Check that the installation complies with installation instructions.</p> <p>Check for correct pipe sizing, see Page 8 – Section 2.19.</p> <p>Clean inlet filters (see maintenance section).</p> <p>Reduce cylinder stat setting to 60 °C max.</p> <p>Clean in accordance with manufacturers instructions.</p>
No hot water.	<p>Air locked water feed.</p> <p>Heat source not operating.</p> <p>All hot water has been used.</p> <p>Faulty thermostatic mixer valve.</p>	<p>Vent hot water pump of air. Check cold feed to hot water cylinder. Check water level in cold water tank and that all stopcocks and isolating valves are open.</p> <p>Check boiler is switched 'on'. Check cylinder thermostat. Check immersion heater. Check cylinder contains hot water.</p> <p>Check tank volume is adequate.</p> <p>Consult makers instructions.</p>
<p>Pump runs on with outlets closed.</p> <p>or</p> <p>Pump cycles (hunts) on/off frequently.</p>	<p>Leak in system.</p> <p>Damaged reed switch, P.C.B or pressure switch.</p> <p>Jammed flow switch.</p> <p>Low pressure in pressure vessel.</p> <p>Debris under non-return valve sealing face.</p>	<p>Check tap washers, w/c valve washers, pipe joints.</p> <p>If pump continues to run, this indicates a closed circuit in either the flow switch reed, pressure switch or P.C.B. in the terminal box. Contact Stuart Turner.</p> <p>Remove outlet hoses and check that flow switch sits in lowest position. Check float for free movement.</p> <p>Check pressure in pressure vessel (see maintenance section).</p> <p>Run at full flow to try and flush away debris or remove, clean or replace non-return valve.</p>
Flexible hose leaks	<p>Not fitted correctly.</p> <p>Damaged 'O'-rings.</p>	<p>Check that the hose is pushed firmly onto the pump inlet/outlet connections and pipework.</p> <p>Check copper pipe ends are cleanly cut and deburred.</p>

Cont ...

8.11 **Dry Run Protection:** This pump is fitted with a safety control circuit, which will detect the following fault condition:

- **Dry running caused by water starvation to the pump.**

Should the pump run out of water it will stop as part of a "protective logic sequence", detailed below.

The fault should be rectified before re-starting the pump. Check that there is sufficient water supply to the pump and also ensure that all terminal fitting outlets are closed.

8.12 **Protective Logic Sequence:** If water starvation occurs and the power supply to the pump remains uninterrupted, the pump controller will perform the following protective sequence.

- 1) If the pump detects water starvation, it will stop operation after a 1 minute period.
- 2) The pump will remain in the off condition for a period of 5 minutes.
- 3) The pump will then re-start and if the water starvation condition remains present, the pump will then stop operation after a 1 minute period.
- 4) The pump will remain in the off condition for a period of 5 minutes.
- 5) The pump will then re-start and if the water starvation condition remains present, the pump will then stop operation after a 1 minute period.
- 6) The pump will remain in the off condition for a period of 5 minutes.
- 7) The pump will then re-start and if the water starvation condition remains present, the pump will then stop operation after a 1 minute period.
- 8) After three consecutive resets are performed the pump will remain in the off condition indefinitely.
- 9) To restart the pump, the power supply should be first isolated for a period of at least 10 seconds before switching on again.

If the pump fails to operate normally after three attempts to re-start, then please contact the TechAssist team on +44 (0) 800 31 969 80.

8.13 **Fault Finding:** The PCB is also fitted with a "power on" indicator light. This will remain illuminated when mains power is supplied to the board. The indicator light is located on the PCB within the terminal box.



- **This operation should only be carried out by a qualified person**

To view the light the following procedure must be followed:-

- Isolate the mains electrical power supply from the pump.
- Remove the four screws retaining the terminal box lid (Fig. 13).
- Lift the terminal box lid off.
- **IMPORTANT** – Ensure there is no contact with any of the internal parts of the terminal box.

Cont ...

- Briefly reconnect the mains power supply to the pump – the 'power on' light should illuminate if the pump has been correctly wired.
- Isolate the mains electrical power supply from the pump.
- Re fit the terminal box lid ensuring no cables are trapped.
- Re fit the four terminal box lid retaining screws, tighten to 0.8 Nm.

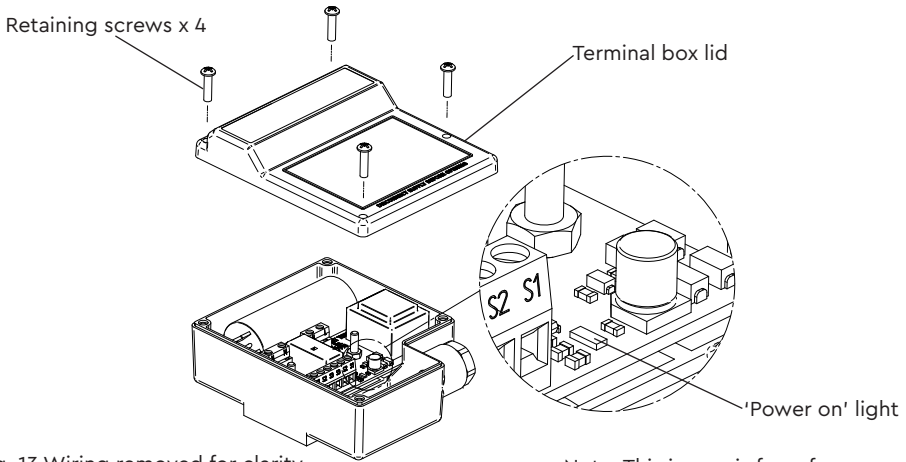

Fig. 13 Wiring removed for clarity

Note: This image is for reference only

8.14 Flow Switch Circuit Test:

1. First confirm visually that the flow switch reed clamp have not been dislodged during handling or installation. The clamp must be fully located within the flow switch body groove as shown.
2. To carry out the following test you will need to obtain a magnet, a typical fridge magnet is suitable.
3. Ensure the power supply is switched on.
4. Position the magnet directly in front of the reed clamp as shown. If pump does not start, then slowly move the magnet up and down to a position that exceeds the extent of the reed clamp.

The pump should instantaneously start at some point during this extent of movement.

If this does not happen, this indicates a possible fault with the reed switch or the P.C.B which is located within the terminal box. These should be checked electrically. Consult Stuart Turner for further instructions.

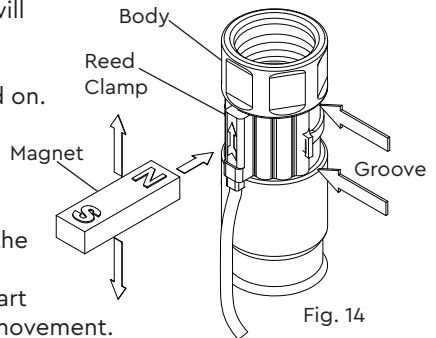

Fig. 14

8.15 Environment Protection: Your appliance contains valuable materials which can be recovered or recycled.

At the end of the products' useful life, please leave it at an appropriate local civic waste collection point.

9 YOUR 2 YEAR GUARANTEE

Congratulations on purchasing a Stuart Turner pump.

We are confident this pump will provide many years of trouble free service as all our products are manufactured to the very highest standard.

All Stuart Pumps are guaranteed to be free from defects in materials or workmanship for 2 years from the date of purchase.

Within the guarantee period we will repair, free of charge, any defects in the pump resulting from faults in material or workmanship, repairing or exchanging the whole unit as we may reasonably decide.

Not covered by this guarantee: Damage arising from incorrect installation, improper use, unauthorised repair, normal wear and tear and defects which have a negligible effect on the value or operation of the pump.

Reasonable evidence must be supplied that the product has been purchased within the guarantee term prior to the date of claim (such as proof of purchase or the pump serial number).

This guarantee is in addition to your statutory rights as a consumer. If you are in any doubt as to these rights, please contact your local Trading Standards Department.

In the event of a claim please telephone '**TechAssist**' or return the pump and flexible hoses with the accessories removed e.g pipes etc. If you have any doubt about removing a pump, please consult a professional.

+44 (0) 800 31 969 80

Proof of purchase should accompany the returned unit to avoid delay in investigation and dealing with your claim.

You should obtain appropriate insurance cover for any loss or damage which is not covered by Stuart Turner Ltd in this provision.

Please record here for your records.

TYPE NO.	SERIAL NO.	DATE PURCHASED
----------	------------	----------------

NOTES



DECLARATION OF CONFORMITY

Machinery Directive - 2006/42/EC

BS EN 12100, BS EN 809

Low Voltage Directive - 2014/35/EU

BS EN 60335-1, BS EN 60335-2-41

EMC Directive - 2014/30/EU

BS EN 55014-1, BS EN 55014-2, BS EN 61000-3-2, BS EN 61000-3-3,
BS EN 61000-4-2, BS EN 61000-4-3, BS EN 61000-4-4, BS EN 61000-4-5, BS EN 61000-4-6,
BS EN 61000-4-11

EMF Directive - 1999/519/EC

BS EN 62233

RoHs Directive - 2011/65/EU

WEEE Directive - 2012/19/EU

IT IS HEREBY CERTIFIED THAT THE STUART ELECTRIC MOTOR DRIVEN PUMP AS SERIAL NUMBER BELOW, COMPLIES WITH THE ESSENTIAL REQUIREMENTS OF THE ABOVE E.E.C. DIRECTIVES.



RESPONSIBLE PERSON
AND MANUFACTURER

STUART TURNER LIMITED
HENLEY-ON-THAMES, OXFORDSHIRE
RG9 2AD ENGLAND.

Signed

Engineering Manager

Stuart Turner are an approved company to BS EN ISO 9001:2015



Stuart Turner Ltd, Henley-on-Thames, Oxfordshire RG9 2AD ENGLAND

Tel: +44 (0) 1491 572655, Fax: +44 (0) 1491 573704

info@stuart-turner.co.uk www.stuart-turner.co.uk