

# MONSOON

## Installation, Operation & Maintenance Instructions

Please leave this instruction booklet with the home owner as it contains important guarantee, maintenance and safety information



**Read this manual carefully before commencing installation.**

This manual covers the following products:

**Monsoon U2.0 bar Single**

Pt. No. 46498      Pt. No. 46498 ROI  
Pt. No. 46498 EXP

**Monsoon U3.0 bar Single**

Pt. No. 46413      Pt. No. 46413 ROI  
Pt. No. 46413 EXP

**Monsoon U4.5 bar Single**

Pt. No. 46414      Pt. No. 46414 ROI  
Pt. No. 46414 EXP

**FOR POSITIVE OR NEGATIVE HEAD APPLICATIONS**



## **PRODUCT DESCRIPTION**

Electric motor driven peripheral pump complete with an automatic control system, consisting of flow switch, pressure switch, pressure vessel and electronic control.

## **APPLICATION**

The Universal Single pumps are suitable for positive or negative head installation conditions. The pumps are designed for pressure boosting applications in vented stored, hot or cold, clean water systems, where under gravity, no flow is available. Inlet pressures to the pump and ambient temperatures must not exceed the values given in the technical specifications.

## **STORAGE**

If this product is not to be installed immediately on receipt, ensure that it is stored in a dry, frost and vibration free location in its original packaging.

## **CONTENTS**

	Page
Checklist .....	.5
Pre-Installation .....	.6
Important Facts – read before commencing installation .....	.7
Location .....	.8
Pump Connections .....	.12
Electrical Installation .....	.15
Commissioning .....	.18
Maintenance .....	.20
Technical Specification .....	.22
Trouble Shooting .....	.24
Guarantee .....	.28

**WARNINGS:**



- This pump set must not be used for any other application without the written consent of Stuart Turner Limited and in particular, must not be connected directly to the mains water supply.
- This appliance can be used by children aged from 8 years and above and persons with reduced physical, sensory or mental capabilities or lack of experience and knowledge if they have been given supervision or instruction concerning use of the appliance in a safe way and understand the hazards involved.
- Children shall not play with the appliance.
- Cleaning and user maintenance shall not be made by children without supervision.
- **WARNING – Washer/condenser dryers and condenser dryers.** The pump must not be used in the water supply line to a washer/condenser drier or a condenser drier, which uses a constant flow of cold water to aid the condenser drying process, as damage can occur to the pump. If in doubt or for further information contact Stuart Turner Ltd.
- The motor casing can become very hot under normal operating conditions. Care must be taken to ensure it cannot be touched during operation.



- The electrical installation must be carried out in accordance with the current national electrical regulations.
- The electrical installation must be installed by a qualified person.
- In the interests of electrical safety a 30 mA residual current device (R.C.D. not supplied) should be installed in the supply circuit. This may be part of a consumer unit or a separate unit.
- Maximum head (closed valve) U2.0 bar twin-20 metres, U3.0 bar twin-30 metres, U4.5 bar twin-45 metres.



- Before starting work on the electrical supply ensure power supply is isolated.
- DO NOT allow the supply cord to contact hot surfaces, including the motor shell, pump body or pipework. The cord should be safely routed and secured by cable clips.
- This appliance must be earthed via the supply cord, which must be correctly connected to the earth point located in the terminal box.
- The supply cord and internal wiring within the terminal box are routed and secured to ensure compliance with the electrical standard EN 60335-1. It is essential that prior to any disturbance of this internal wiring, all cable routing and securing details are carefully noted to ensure re-assembly to the same factory pattern is always maintained.
- If the supply cord is to be changed or is damaged, it must be replaced with a special cord assembly available from Stuart Turner or one of their approved repairers.

Please read installation details carefully as they are intended to ensure this product provides long, trouble free service. Failure to install the unit in accordance with the installation instructions will lead to invalidation of the warranty.

# CHECKLIST

**IMPORTANT:** With the pump removed from its packaging check for any damage prior to installation. If any damage is found contact Stuart Turner Ltd within 24 hours of receipt.

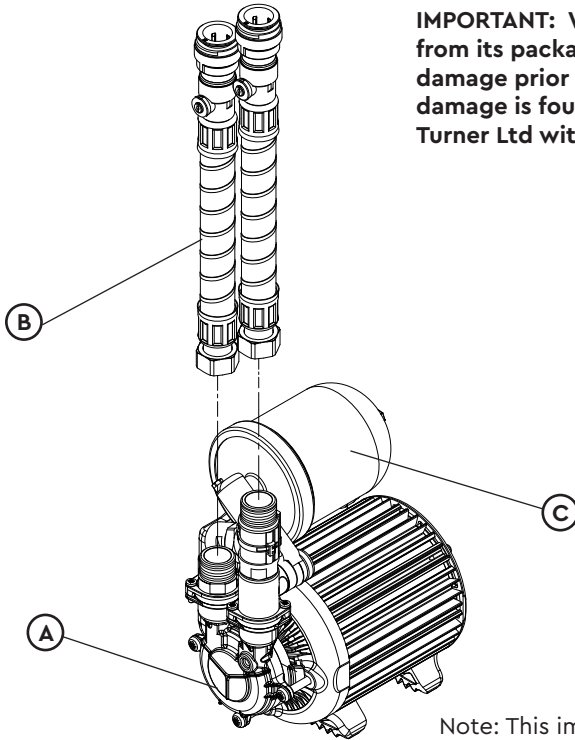

Fig. 1

Note: This image is for reference only

Item	Description	Qty	Item	Description	Qty
(A)	Pump	1	(C)	Tank & sealing washer	1
(B)	Hose & integral washer	2			

Your product may vary slightly from the picture above.



## REGIONAL SUITABILITY

**Before commencing installation, ensure the product you have purchased is correct for your region, to avoid invalidating the guarantee.**

**Check the part number:**

**Example:**

UK product	Pt. No. 46410
ROI product	Pt. No. 46410 ROI
Export product	Pt. No. 46410 EXP

Cont ...

- This installation book refers to UK pipework and pumps supplied with hoses suitable for 22 mm pipework.
- If you have purchased a product suitable for ROI (Republic of Ireland) it will be supplied with hoses suitable for 21 mm pipework.
- If you have purchased a product suitable for Export it will be supplied with hoses suitable for G ¾ connections.

## PRE-INSTALLATION CHECK

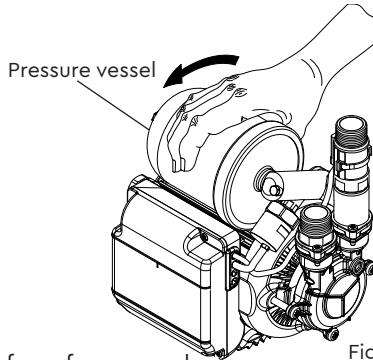

Fig. 2

Note: This image is for reference only

The pressure vessel (Fig. 2) is factory fitted to the pump assembly. To eliminate any risk that the vessel has lost its assembly torque and sealing ability during transit, it must be checked prior to installation and should be hand tight.

**Note: Do not overtighten pressure vessel.**

## 1 IMPORTANT FACTS: READ BEFORE COMMENCING PUMP INSTALLATION

### A Water storage capacity.

- 1.11 The hot and cold water storage capacity must be sufficient to meet the flow rates required by the pumped equipment and any other water using fittings and appliances, which may be operated simultaneously.
- 1.12 Ensure the pump is primed as described in the priming section before starting, damage to the shaft seal will result otherwise. See Section 5 – Commissioning.

### B Water temperature

The water entering the pump must be controlled as follows:

- 1.13 The maximum allowable water temperature is 65 °C.
- 1.14 The minimum allowable water temperature is 4 °C.
- 1.15 **DO NOT** fit a pump if the hot water is heated via a method whereby the water temperature cannot be controlled, such as solar or solid fuel you must consult the TechAssist team on +44 (0) 800 31 969 80.

### C Pipework – General

- 1.16 **Secure pipework:** Ensure pipework to and from pump is independently supported & clipped to prevent forces being transferred to inlet and outlet branches of pump.
- 1.17 **Flux:** Solder joints must be completed and flux residues removed prior to pump installation (**flux damage will void any warranty**).
- 1.18 **Pipework design:** Care should be taken in the design of pipework runs to minimize the risk of air locks e.g. use drawn bends rather than 90° bends.



- 1.19 **DO NOT** introduce solder flux to flexible hoses, pumps or pump parts manufactured from plastic.

- 1.20 **DO NOT** allow contact with oil or cellulose based paints, paint thinners or strippers, acid based descalents or aggressive cleaning agents.



- 1.21 **DO NOT** install a non-return valve, or devices which contain non-return valves, in the suction (inlet) pipework to the pump. The pump must be free to vent to the supply tank at all times.

- 1.22 **DO NOT** bend the flexible hoses beyond 30°. They must be installed as straight as possible.

- 1.23 **DO NOT** connect this pump to the mains water supply.

### D Plumbing Installation Regulations

- 1.24 The plumbing installation must comply with the current water and building regulations.
- 1.25 The plumbing installation must be installed by a qualified person.

### E Pressure vessel

- 1.26 Pressure vessel is charged at the factory see Section 6 – Maintenance for details.

## 2 LOCATION – GENERAL



- 2.11 **Access:** For emergencies and maintenance the pump must be easily accessible.
- 2.12 **Protection:** The pump must be located in a dry position, frost free and protected from freezing, particularly when installed in a loft (not recommended).
- 2.13 **Ventilation:** Ensure an adequate air flow to cool the pump. Separate the pump from other appliances that generate heat. An 80 mm (3 ") air gap must be maintained around the pump.
- 2.14 **Safety:** The motor casing can become very hot under normal operating conditions. Care must be taken to ensure it cannot be touched during operation.
- 2.15 **Water retention:** Site the pump in a location where in the unlikely event of a water leak, any spillage is contained or routed to avoid electrics or areas sensitive to water damage.
- 2.16 **Static inlet pressure:** Before deciding where to position the unit, check to ensure the static inlet and outlet heads of water above the pump (Table 1), does not exceed the maximum permitted limits.
- 2.17 **Ambient temperature:** The pump must be sited in a location where the maximum ambient temperature does not exceed 40 °C.
- 2.18 **Pipework:** For optimum performance pipework **MUST** be 22 mm (21 mm in ROI). Pipework should only reduce to 15 mm when entering terminal fitting.
- 2.19 **Static outlet pressure:** The static outlet head must not exceed the values shown in table 1.
- 2.20 **Noise:** The anti-vibration mounting feet and flexible hoses which are supplied as standard, and a precaution to reduce noise transmission, however care must be taken when mounting the pump that any noise is not amplified through loose panels or pipework. **Do not screw down the pump.**
- 2.21 **Direction of flow:** Ensure the water flow is in the direction of the arrow that is marked on the flow switch reed clamp (vertically upwards).
- 2.22 **Flexible hoses:** Only use the Stuart Turner hose set supplied with the pump.
- 2.23 **Isolating valves:** Separate system isolating valves (non restrictive) must be fitted to allow easy pump service.
- 2.24 **Preferred pump location:** The pump must, for optimum performance, be sited as close as possible to and never more than 4 metres from the HOT WATER cylinder. The pump should always be sited BELOW the HOT WATER take-off from the cylinder. The pump location is also dependent on limitations of the static inlet and outlet heads of the installation. For guidance on limitations and recommended location, consult the following relevant section for hot or cold water installation.



2.25 **Non-preferred pump location:** If it is necessary to position the Pump above the secondary tapping on the hot cylinder it is fed by, the risk of introducing air will be increased.

To avoid this risk one of the two following solutions must be adopted:  
The use of a Top Entry cylinder flange.

The use of a Stuart Side Entry (SE) cylinder flange, which should have the addition of an inverted loop ("U" bend) of 350 mm minimum drop before rising to the pump, located as close as possible to the cylinder wall. Please note both flange options listed above are designed to suit 22 mm pipework. If used in ROI a suitable adaptor to 21 mm pipe must be used (not supplied). This will ensure the pump receives an air free supply and the cylinder vents any air up the vent pipe and not the pump feed (Fig. 3).

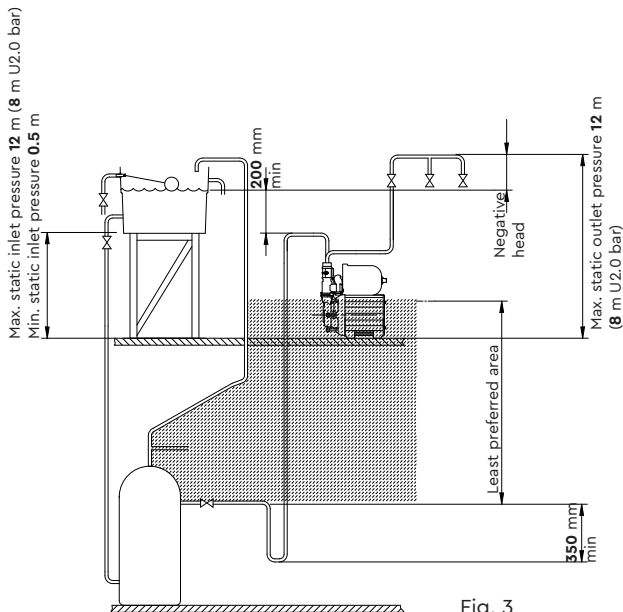

Fig. 3

## 2 LOCATION – COLD WATER

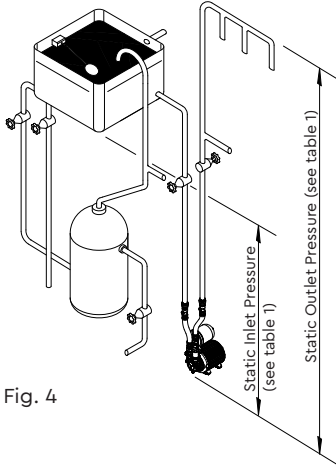

Fig. 4

Model	Min. static inlet pressure (m)	Max. static inlet pressure (m)	Max. static outlet pressure (m)
U2.0 bar Single	0.5	8	8
U3.0 bar Single	0.5	12	12
U4.5 bar Single			

- 2.26 **The cold water supply: Must be a DEDICATED AIR FREE** supply via a tank connector, and must be positioned at a slightly lower level (25 mm minimum) than the feed pipe to the hot water cylinder.  
**Do not connect to the mains.**

## 2 LOCATION – HOT WATER

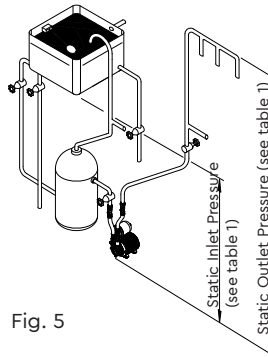
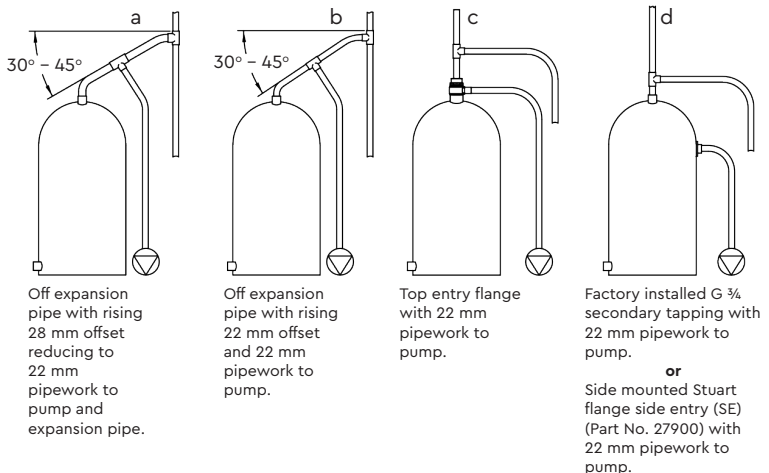

Fig. 5

### Hot water connection:

- 2.27 **Hot water cylinder or storage tank:** When a hot water cylinder or storage tank is used, ensure the pipework size from the cold water storage to the hot water storage is of adequate size and a minimum of 22 mm. The U4.5 bar Single should have pipework of a minimum of 28 mm.
- 2.28 **Hot water supply:** The pump **must** be supplied with a **dedicated feed** direct from the hot water cylinder or storage tank, ensuring an air free connection to the pump. We recommend the use of either the side entry Stuart flange (SE) Part No 27900 or a top entry flange see Fig. 6 (for all models except the U4.5 bar Single) (U4.5 bar Single should only use 'a' or 'd'). Please note both flange options listed above are designed to suit 22 mm pipework. If used in ROI a suitable adaptor to 21 mm pipe must be used (not supplied).
- 2.29 **Expansion pipe:** When the method of connection is to be made via the expansion pipe, the **BASE** of the cold water storage tank **MUST** be at least 1 metre above the connection/take off of the hot water storage cylinder feeding the pump.

Fig. 6



**For applications in ROI pipe sizes above should read 21 mm.**

Cont ...

### 3 PUMP CONNECTIONS



- Do not use stainless steel, chrome or nickel plated pipe with the flexible hose push-in plumbing connections.
- Do not introduce solder flux into the joint or surrounding area as connectors will be attacked and may fail.
- All solder joints should be completed and flux residues removed before final connection to push-in connections, on the flexible hose.
- Do not allow contact with oil or cellulose based paints, paint thinners or strippers, acid based descalents or aggressive cleaning agents.
- Never operate pump with inlet and/or outlet isolating valves in the closed position. Damage will occur!

3.11 **Hose to pump:** The pump inlet and outlet ports have factory assembled fittings which are specifically designed for connection to the G $\frac{3}{4}$  female running nuts on the flexible hoses. The hose end is fitted with a rubber sealing washer which is held captive within the nut assembly. Locate the hose into position and screw the nut fully onto the fitting by hand. Finally nip tight with a spanner (4/5 Nm) for a water tight seal (**do not overtighten**).

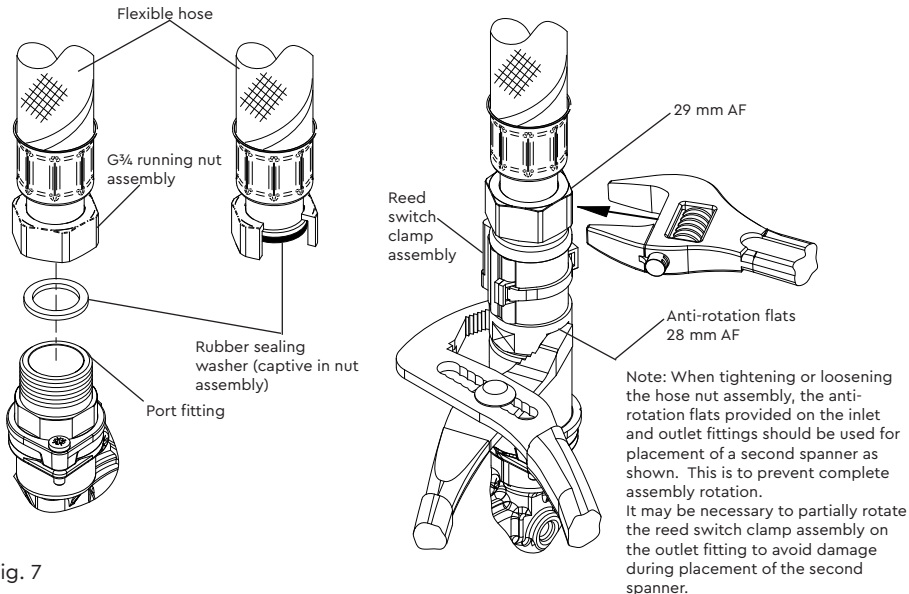

Fig. 7

### 3.12 Hose to pipework:

1. The hoses are fitted with plastic push-in connectors, which must only be connected to the following:
  - 22 mm dia. pipework in the UK
  - 21 mm dia pipework in the ROI

Ensure the pipe is free from all score marks and deformities in the area of the insertion depth (Fig. 8) and cut the pipe square removing all burrs and sharp edges to prevent damage to the sealing 'O'-ring.

2. Prior to inserting pipe into fitting mark the insertion depth on the wall of the pipe with a soft pencil at a distance of 33 mm from the end to be inserted.

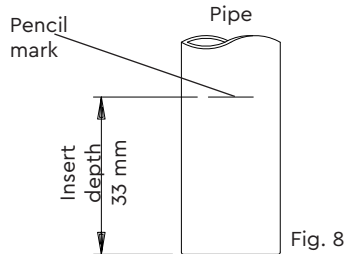

3. Check in the mouth of the fitting that 'O'-ring, nylon washer and collet are in position.

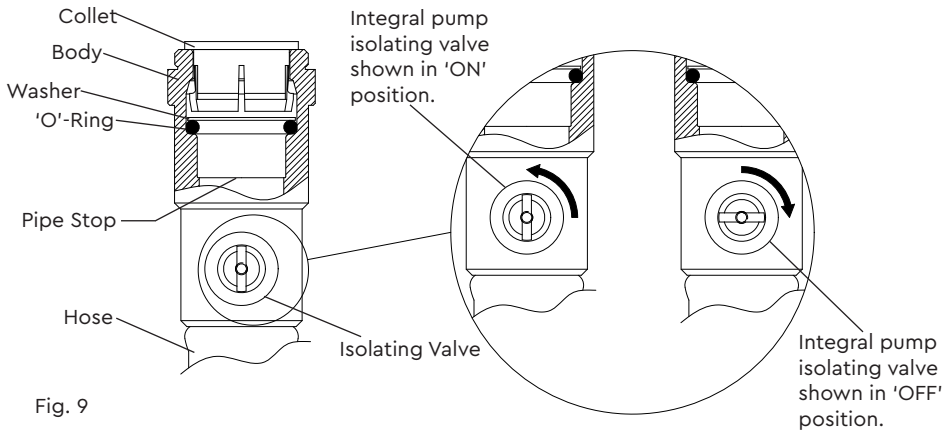

4. Push pipe firmly into fitting, until pencil mark is level with the top of the collet and the pipe stop resistance is felt. Pull on pipe to check it is secure and correctly fitted.
5. To break the joint, push pipe firmly into fitting, hold collet down and gently remove pipe. If the system has been filled with water care should be taken to isolate pump and towels used to absorb spilled water.

### 3.13 Typical Low Level Installation:

In certain installations it may be necessary to install a 90° bend on the inlet or outlet connections of the pump before the flexible hose to accommodate a low level installation.

Below are some preferred connection options. All connections seal on the pump body using a fibre or rubber sealing washer. Tap connector fittings should be used which must be of an appropriate pressure and temperature rating.

It is essential when using any of the fittings shown below, that a correct water tight seal is obtained between the pump body and selected fitting and also the flexible hose and selected fitting. If in doubt contact the fitting manufacturer and confirm compatibility with the connection to be sealed.

Carefully check connections and pipework for leaks whilst pump running and stationary before leaving the installation unattended.

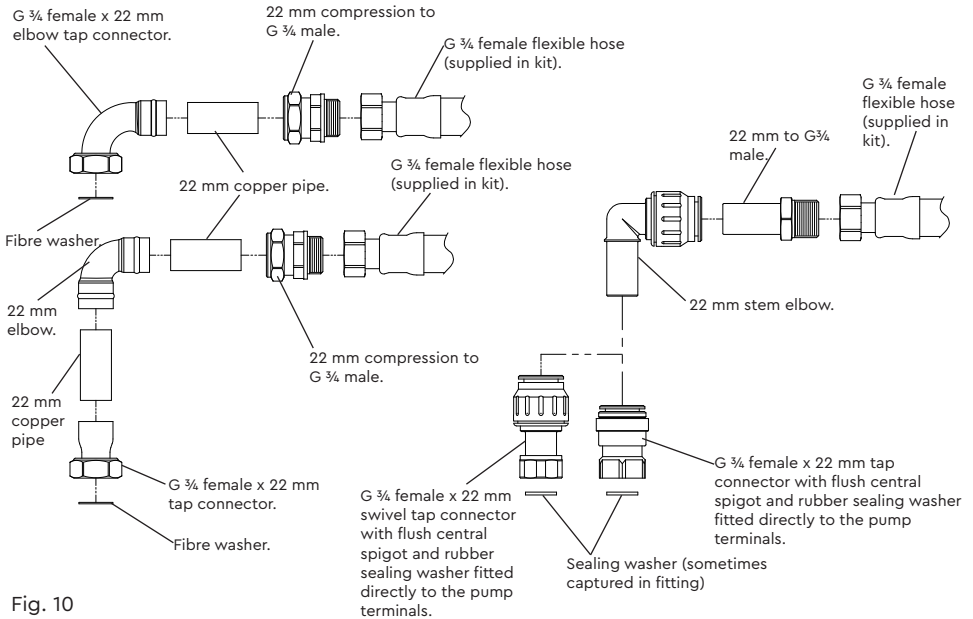

Fig. 10

**If you have any concern either about using push-in fittings or should the joint leak on final test isolate the water supplies and contact TechAssist on +44 (0) 800 31 969 80.**



**For applications in ROI pipe sizes above should read 21 mm.**

## 4 ELECTRICAL INSTALLATION



- 4.11 **Regulations:** The electrical installation must be carried out in accordance with the current national electrical regulations and installed by a qualified person.
- 4.12 **Safety:** In the interests of electrical safety a 30 mA residual current device (**R.C.D. not supplied**) should be installed in the supply circuit. This may be part of a consumer unit or a separate unit.
- 4.13 Before starting work on the electrical supply ensure power supply is isolated.
- 4.14 **DO NOT** allow the supply cord to contact hot surfaces, including the motor shell, pump body or pipework. The cord should be safely routed and secured by cable clips.
- 4.15 **Adjacent pipes:** Adjacent suction and delivery pipes should be fitted with earthing clamps and connected with earthing wire size 4 mm<sup>2</sup> (Fig. 11).

Diagram of  
earth continuity  
connections

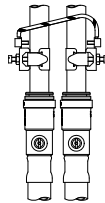

Fig. 11

- 4.16 **Earthing:** This appliance must be earthed via the supply cord, which must be correctly connected to the earth point located in the terminal box.
- 4.17 **Pipework:** Copper or metallic pipework must have supplementary earth bonding where the continuity has been broken by flexible hoses or plastic components.
- 4.18 **Additional earthing:** Certain installations may require additional earthing arrangements such as equipotential bonding. Reference should be made to the relevant regulations concerning this subject to ensure compliance.
- 4.19 **Connections:** The pump must be permanently connected to the fixed wiring of the mains supply using the factory fitted supply cord, via a double pole switched fused spur off the ring main and **NOT** connected to the boiler or the immersion heater circuits.
- 4.20 **Wiring Of Connection Unit:**



**WARNING: This appliance must be earthed.**

The wires in the mains lead (supply cord) are coloured in accordance with the following code:

- Green and Yellow: Earth
- Blue: Neutral
- Brown: Live

As the colours of the wires in the mains lead of this appliance may not correspond with the coloured markings identifying the terminals in your connection unit proceed as follows:

- The wire which is coloured green and yellow must be connected to the terminal in the connection unit which is marked with the letter E or by the earth symbol:  $\oplus$  or coloured green or green and yellow.
- The wire which is coloured blue must be connected to the terminal which is marked with the letter N or coloured black.
- The wire which is coloured brown must be connected to the terminal which is marked with the letter L or coloured red.

#### 4.21 Wiring Diagram:

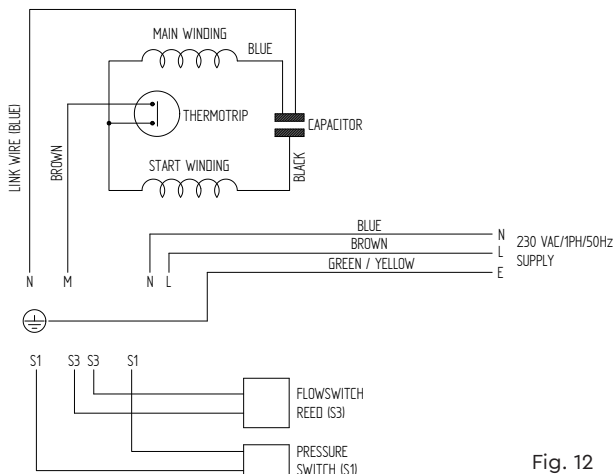

Fig. 12

4.22 **Fuses:** The following fuse size should be used with the appropriate pump.

Model	Fuse Size (AMPS)
All Models	5

#### 4.23 Supply Cord Replacement:



**The supply cord and internal wiring within the terminal box are routed and secured to ensure compliance with the electrical standard EN 60335-1. It is essential that prior to any disturbance of this internal wiring, all cable routing and securing details are carefully noted to ensure re-assembly to the same factory pattern is always maintained.**

If the supply cord is to be changed or is damaged, it must be replaced with a special cord assembly available from Stuart Turner or one of their approved repairers.

On disassembly note the cord retention and routing system. Re-assemble to the same pattern.

For information on cable connection consult the wiring diagram and cable gland fitting instructions.



**4.24 Cable Gland Fitting Instructions:**

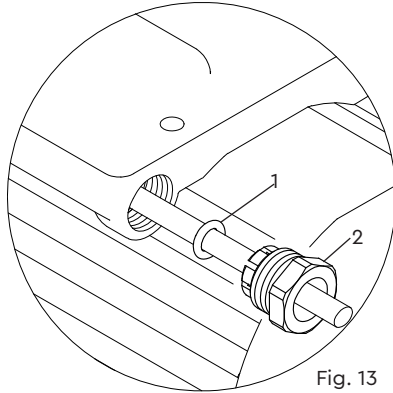

Fig. 13

To enable correct assembly of the cable gland the 'O'-ring (Fig. 13 item 1) must be placed over the cable before the clamping insert (Fig. 13 item 2) can be tightened.

Note: Cable diameter range:- 6.5 mm to 9.5 mm.

**4.25 Supply Cord Extension:**

The pumps are fitted with a supply cord to the following specification:-

All models. . . . .HO5VV-F3 G 0.75 mm<sup>2</sup> – 6 Amp rated cable.

If the supply cord is to be extended, a cord of the same specification should be used. Any connections or junction boxes used should be specifically suited for the application and installed in accordance with the manufacturers instructions.

## 5 COMMISSIONING



5.11 **System Flushing:** This pump incorporates push-in connectors and plastic components that must not come into contact with solder flux, acid-based descalents or aggressive cleaning agents. The pipework system should be flushed out prior to the pump being connected to ensure any contaminants/chemical residues and foreign bodies are removed from elsewhere in the system.

5.12 **Water Supply:** Always ensure that water storage capacity is adequate to meet the demand. Ensure the pump chamber is full of water before starting the pump. Failure to do this could result in seal damage. To ensure dry running does not occur the pump must be primed as described in priming section below. **Do not run pump dry.**

5.13 **Priming:**



**Never operate pump with inlet and/or outlet isolating valves in the closed position. Damage will occur!**

The pump must be primed (filled with water) before starting. Turn on the service valves (1), and vent/prime pump head.

- (a) Loosen priming plug (2) and allow an even flow of water this may take a few seconds.
- (b) Re-seal draining plug, nipping tight. The pump is now ready to start.

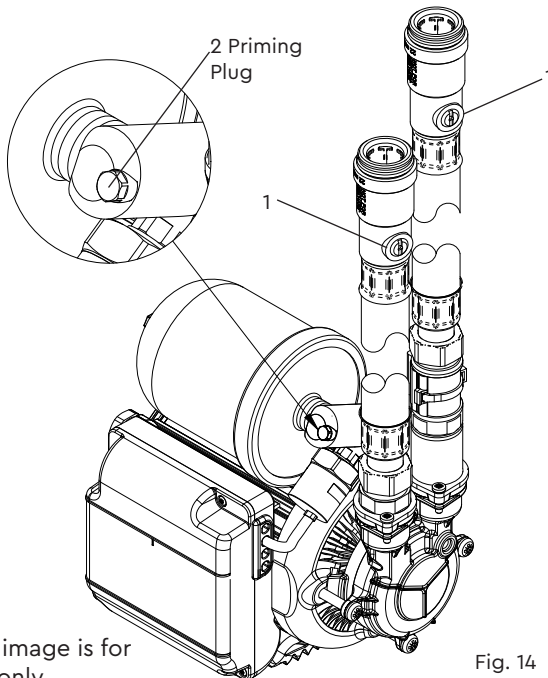

Note: This image is for reference only

Fig. 14

Cont ...

5.14 **Starting:**

- a) Ensure all outlets are closed, turn power supply 'on' – pump will start, pressurise the system then stop.
- b) Open and close all outlets in turn associated with the pump, (including w/c systems) allowing water to flow from each outlet until all air is purged. As each outlet is opened and closed, the pump will start and stop respectively.

Note: After closing the outlet there will be a small time delay before the pump stops, which is normal.

- c) Any tap or control valve within the system when opened and closed will now turn the pump on/off. Providing this is the case the system is now operating correctly.
- d) Carefully check pump and pipework for leaks whilst pump running and stationary before leaving the installation unattended.

5.15 **For Further Technical Support:** Phone the Stuart Turner TechAssist team on +44 (0) 800 31 969 80. Our staff are trained to help and advise you over the phone.

## 6 MAINTENANCE



6.11 Turn off water supplies to the pump and release pressure by opening water outlets before attempting maintenance.

- 6.12 **Inlet strainer:** The inlet strainers may require periodical cleaning. The frequency of this operation is dependent upon installation conditions. The strainer is located in the inlet assembly of the pump casing (Fig. 15) and is removed as follows:-
- Isolate pump electrically.
  - Release all system pressure.
  - Isolate hot and cold water supplies via the integral pump isolating valve located in the flexible hoses and release hose nuts connected to the pump (see Section 3 – Pump Connections).
  - Remove M4 screws (2 off) from inlet assembly, lift brass inlet fitting (with 'O'-ring) and clamp away from pump casing (Fig. 15).
  - Remove strainer with long nose pliers noting location lug position upon removal (Fig. 15) and clean thoroughly.
  - Refit strainer taking care to position lug in body inlet port location slot (Fig. 15) and re-assemble pipework. Tighten M4 clamp screws to 1.5 Nm torque.
  - After maintenance is completed refer to Section 5 – Commissioning for instructions on re-starting pump.

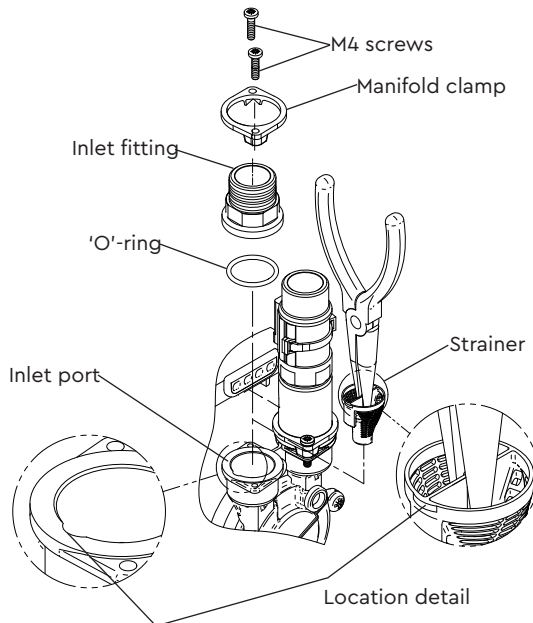

Fig. 15

6.13 No other routine maintenance is required.

Cont ...

- 6.14 Should ever the need arise for the vessel to have its air charge checked or replenished, it should be carried out as follows: –
- Isolate pump electrically.
  - Isolate hot and cold water supplies via the integral pump isolating valve located in the flexible hoses (see Section 3 – Pump Connections).
  - Release system water pressure by opening a system outlet (tap).
  - Check air charge at Schrader valve (Fig. 16) using a tyre pressure gauge.

Model	Vessel Pressure		
	KpA	bar	psi
U2.0 bar Single	90	0.9	13
U3.0 bar Single	130	1.3	18.5
U4.5 bar Single			

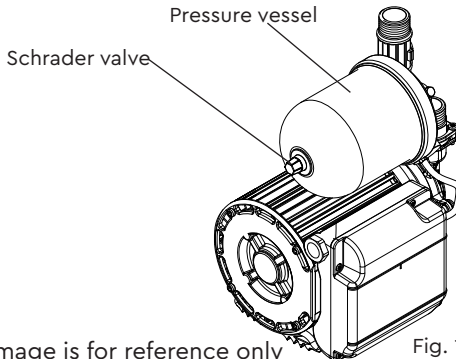

Note: This image is for reference only Fig. 16

- Replenish air charge if required by injecting air into the vessel via the Schrader valve using a car or bicycle pump, ensuring a system outlet valve (tap) remains open during this procedure to allow the vessel to exhaust any excess water.
  - Close all system taps, open hot and cold inlet pump isolating valves, turn on electrical power.
  - After maintenance is completed refer to Section 5 – Commissioning for instructions on re-starting pump.
- 6.15 **Water scale:** As water is heated scale deposits are released in areas of hard water, scale can cause the mechanical seal to stick if left without use for long periods. The pump must be run for at least 5 minutes every four weeks to exercise" all working parts. Run on cool water. See Section 7 – Technical Specification for note on water temperature. This particularly applies to guest bathrooms used infrequently.
- 6.16 **Cleaners, Disinfectants and Descalents:**



Acid based descalents and aggressive cleaning agents must not come into contact with the pump. The pump must be removed from the system prior to the use of these products. The system should be flushed to remove all chemicals before the pump is re-connected.

If in any doubt as to the suitability of the chemical solutions, please contact our TechAssist helpline on +44 (0) 800 31 969 80.

## 7 TECHNICAL SPECIFICATION

Pump Model		U2.0 bar Single 46498	U3.0 bar Single 46413	U4.5 bar Single 46414
General	Guarantee	5 years		
	WRAS approval	1906076		
	Approvals	WRAS, CE		
Features	Pump type	Peripheral		
	Mechanical seal	EPDM / PTFE / Al. Oxide		
	Anti-vibration feet	✓	✓	✓
	Inlet strainer(s)	✓	✓	✓
	Flexible hoses	2	2	2
	Run on Timer	3 sec	3 sec	3 sec
	Dry run protection	✓	✓	✓
	Noise (dB(A))	42	48	55
Materials	Pump body	Brass		
	Impeller	Brass		
Performance	Maximum head (closed valve)	2.0 bar (20 metres)	3.2 bar (32 metres)	4.5 bar (45 metres)
	Performance @ 9 l/min	1.2 bar	2.5 bar	3.5 bar
	Performance @ 18 l/min	N/A	0.9 bar	1.7 bar
	Maximum flow	18 l/min	22 l/min	26 l/min
	Maximum static inlet pressure	8 metres	12 metres	
	Maximum static outlet pressure	8 metres	12 metres	
	Maximum working pressure*	600 kPa (6 bar)		
	Maximum ambient air temperature	40 °C		
	Min / Max water temperature**	Min 4 °C / Max 65 °C		
	Flow switch sensitivity (approx)	0.6 l/min		
	Pressure vessel air pre-charge	0.9 bar (13 psi)	1.3 bar (18.5 psi)	
Connections	Pump connections	G ¾ male		
Flexible hoses	Connections (UK model)	G ¾ female x 22 mm push-in x 300 mm long, isolating valves on all hoses		
	Connections (ROI model)	G ¾ female x 21 mm push-in x 300 mm long, isolating valves on all hoses		
	Connections (Export model)	G ¾ female x G ¾ female x 300 mm long		
Motor	Type	Induction, auto-reset thermal trip		
	Duty rating	Continuous (S1) @ 9 l/min and above		
Electrical	Power supply / phase / frequency	230 V a.c. / 1 / 50 Hz		
	Current (full load)	1.1 Amps	1.7 Amps	2.5 Amps
	Power consumption	250 Watts	390 Watts	555 Watts
	Fuse rating	5 Amps		
	Power cable (pre-wired)	1.5 metres		
Physical	Enclosure protection	IPX4		
	Length	200 mm		
	Width	162 mm		
	Height (excluding hoses)	243 mm		
	Weight (including fittings)	6.6 Kg		7.3 Kg

Stuart Turner reserve the right to amend the specification in line with its policy of continuous development of its products.

Note: For information on other voltages/frequencies which are not shown, consult TechAssist on +44 (0) 800 31 969 80.

\*Note: The maximum pressure that can be applied to the pump under any installation conditions.

\*\*Note: A stored water temperature of 60°C is considered sufficient to meet all normal requirements and will minimize deposition of scale in hard water areas.



**Maximum permissible water temperature 65°C.**

7.11 **Noise:** The equivalent continuous A-weighted sound pressure level at a distance of 1 metre from the pump does not exceed 70 dB(A).

## 8 TROUBLE SHOOTING GUIDE

Symptoms	Probable Cause	Recommended Action
Pump will not start.	<p>Electrical supply.</p> <p>Pump Jammed.</p> <p>Damaged pressure switch.</p> <p>Recommended static inlet/ outlet heads exceeded.</p> <p>Internal motor thermotrip activated.</p>	<p>Check power supply. Check fuse (see fuse section). Check circuit breaker is set. Check wiring connections.</p> <p>If motor 'Buzzes' switch off power and contact Stuart Turner.</p> <p>Turn off power. Release system water pressure. Turn on power, pump should start. If NOT contact Stuart Turner.</p> <p>Re-position pump (see pump location section).</p> <p>Wait for thermotrip to auto-reset and check that duty point and run time is within specification (see technical specification).</p>
Reduced/intermittent flow.	<p>Incorrect or no anti-aeration flange fitted</p> <p>Incorrect pipe sizes.</p> <p>Blocked inlet filters.</p> <p>Hot water temperature set too high.</p> <p>Blocked shower head spray plate</p>	<p>Check that the installation complies with installation instructions.</p> <p>Check for correct pipe sizing, see Page 8 – Section 2.18.</p> <p>Clean inlet filters (see maintenance section).</p> <p>Reduce cylinder stat setting to 60 °C max.</p> <p>Clean in accordance with manufacturers instructions.</p>
No hot water.	<p>Air locked water feed.</p> <p>Heat source not operating.</p> <p>All hot water has been used.</p> <p>Faulty thermostatic mixer valve.</p>	<p>Vent hot water pump of air. Check cold feed to hot water cylinder. Check water level in cold water tank and that all stopcocks and isolating valves are open.</p> <p>Check boiler is switched 'on'. Check cylinder thermostat. Check immersion heater. Check cylinder contains hot water.</p> <p>Check tank volume is adequate.</p> <p>Consult makers instructions.</p>
<p>Pump runs on with outlets closed.</p> <p>or</p> <p>Pump cycles (hunts) on/off frequently.</p>	<p>Leak in system.</p> <p>Damaged reed switch, P.C.B or pressure switch.</p> <p>Jammed flow switch.</p> <p>Low pressure in pressure vessel.</p> <p>Debris under non-return valve sealing face.</p>	<p>Check tap washers, w/c valve washers, pipe joints.</p> <p>If pump continues to run, this indicates a closed circuit in either the flow switch reed, pressure switch or P.C.B. in the terminal box. Contact Stuart Turner.</p> <p>Remove outlet hoses and check that flow switch sits in lowest position. Check float for free movement.</p> <p>Check pressure in pressure vessel (see maintenance section).</p> <p>Run at full flow to try and flush away debris or remove, clean or replace non-return valve.</p>
Flexible hose leaks	<p>Not fitted correctly.</p> <p>Damaged 'O'-rings.</p>	<p>Check that the hose is pushed firmly onto the pump inlet/ outlet connections and pipework.</p> <p>Check copper pipe ends are cleanly cut and deburred.</p>



8.11 **Dry Run Protection:** This pump is fitted with a PCB that will detect the following fault conditions:

- **Dry running caused by water starvation to the pump.**

Should the pump run out of water it will stop as part of a "protective logic sequence".

The fault should be rectified before re-starting the pump. Check that there is sufficient water supply to the pump and also ensure that all terminal fitting outlets are closed.

8.12 **Protective Logic Sequence:** If water starvation occurs and the power supply to the pump remains uninterrupted, the pump controller will perform the following protective sequence.

- 1) If the pump detects water starvation, it will stop operation after a 1 minute period.
- 2) The pump will remain in the off condition for a period of 5 minutes.
- 3) The pump will then re-start and if the water starvation condition remains present, the pump will then stop operation after a 1 minute period.
- 4) The pump will remain in the off condition for a period of 5 minutes.
- 5) The pump will then re-start and if the water starvation condition remains present, the pump will then stop operation after a 1 minute period.
- 6) The pump will remain in the off condition for a period of 5 minutes.
- 7) The pump will then re-start and if the water starvation condition remains present, the pump will then stop operation after a 1 minute period.
- 8) After three consecutive resets are performed the pump will remain in the off condition indefinitely.
- 9) To restart the pump, the power supply should be first isolated for a period of at least 10 seconds before switching on again.

If the pump fails to operate normally after three attempts to re-start, then please consult Stuart Turner TechAssist +44 (0) 800 31 969 80.

8.13 **Fault Finding:** The PCB is also fitted with a "power on" indicator light. This will remain illuminated when mains power is supplied to the board. The indicator light is located on the PCB within the terminal box.



- **This operation should only be carried out by a competent person**

To view the light the following procedure must be followed:-

- Isolate the mains electrical power supply from the pump.
- Remove the four screws retaining the terminal box lid (Fig. 17).
- Lift the terminal box lid off.

- **IMPORTANT** – Ensure there is no contact with any of the internal parts of the terminal box.
- Briefly reconnect the mains power supply to the pump – the 'power on' light should illuminate if the pump has been correctly wired.
- Isolate the mains electrical power supply from the pump.
- Re fit the terminal box lid ensuring no cables are trapped.
- Re fit the four terminal box lid retaining screws, tighten to 0.8 Nm.

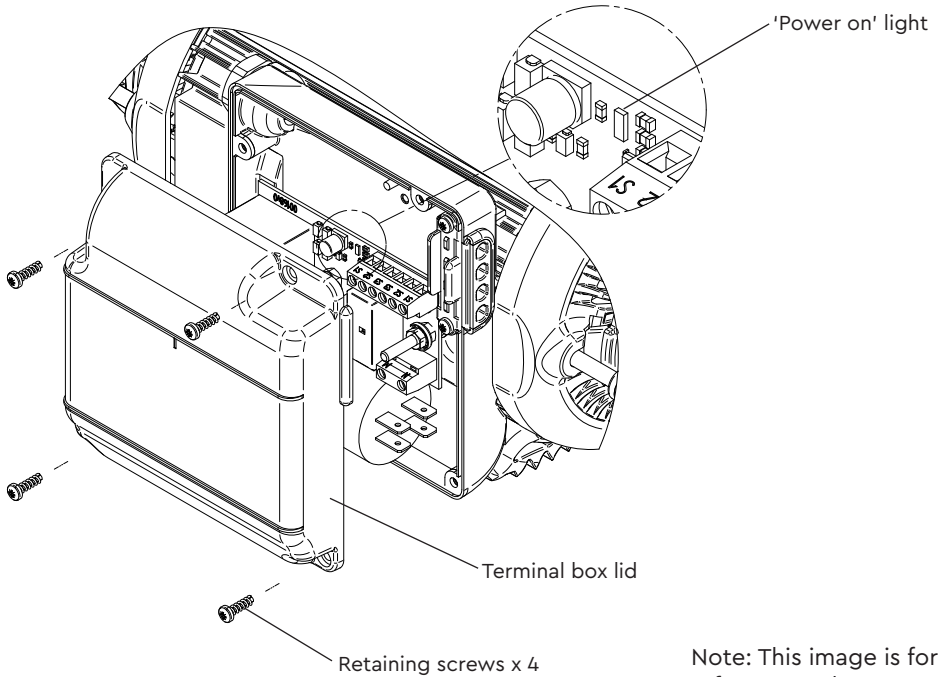

Fig. 17 Wiring removed for clarity

Note: This image is for reference only

#### 8.14 Flow Switch Circuit Test:

1. First confirm visually that the flow switch reed clamps have not been dislodged during handling or installation. The clamps must be fully located within their flow switch body groove as shown.
2. To carry out the following test you will need to obtain a magnet, a typical fridge magnet is suitable.
3. Ensure the power supply is switched on.
4. Position the magnet directly in front of the reed clamp as shown. If pump does not start, then slowly move the magnet up and down to a position that exceeds the extent of the reed clamp. The pump should instantaneously start at some point during this extent of movement. If this does not happen, this indicates a possible fault with the reed switch or the P.C.B which is located within the terminal box. These should be checked electrically. Consult Stuart Turner for further instructions.

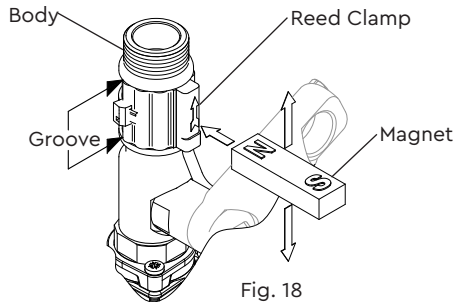

Fig. 18

- 8.15 **Environment Protection:** Your appliance contains valuable materials which can be recovered or recycled. At the end of the products' useful life, please leave it at an appropriate local civic waste collection point.

## 9 THE MONSOON GUARANTEE

Congratulations on purchasing a Stuart Turner pump.

We are confident this pump will provide many years of trouble free service as all our products are manufactured to the very highest standard.

All Monsoon Pumps are guaranteed to be free from defects in materials or workmanship for 5 years from the date of purchase.

Within the guarantee period we will repair, free of charge, any defects in the pump resulting from faults in material or workmanship, repairing or exchanging the whole unit as we may reasonably decide.

Not covered by this guarantee: Damage arising from incorrect installation, improper use, unauthorised repair, normal wear and tear and defects which have a negligible effect on the value or operation of the pump.

Reasonable evidence must be supplied that the product has been purchased within the guarantee term prior to the date of claim (such as proof of purchase or the pump serial number).

This guarantee is in addition to your statutory rights as a consumer. If you are in any doubt as to these rights, please contact your local Trading Standards Department.

Ensure the product you have purchased is correct for your region to avoid invalidating the guarantee.

In the event of a claim please telephone '**TechAssist**' or return the pump and flexible hoses with the accessories removed e.g pipes etc. If you have any doubt about removing a pump, please consult a professional.

**+44 (0) 800 31 969 80**

Proof of purchase should accompany the returned unit to avoid delay in investigation and dealing with your claim.

You should obtain appropriate insurance cover for any loss or damage which is not covered by Stuart Turner Ltd in this provision.

Please record here for your records.

TYPE NO.	SERIAL NO.	DATE PURCHASED
----------	------------	----------------

Cont ...

## NOTES

## NOTES

## NOTES



**DECLARATION OF CONFORMITY**

**Machinery Directive – 2006/42/EC**

BS EN 12100, BS EN 809

**Low Voltage Directive – 2014/35/EU**

BS EN 60335-1, BS EN 60335-2-41

**EMC Directive – 2014/30/EU**

BS EN 55014-1, BS EN 55014-2, BS EN 61000-3-2, BS EN 61000-3-3,  
BS EN 61000-4-2, BS EN 61000-4-3, BS EN 61000-4-4, BS EN 61000-4-5, BS EN 61000-4-6,  
BS EN 61000-4-11

**EMF Directive – 1999/519/EC**

BS EN 62233

**RoHs Directive – 2011/65/EU**

**WEEE Directive – 2012/19/EU**

IT IS HEREBY CERTIFIED THAT THE STUART ELECTRIC MOTOR DRIVEN PUMP AS SERIAL NUMBER BELOW, COMPLIES WITH THE ESSENTIAL REQUIREMENTS OF THE ABOVE E.E.C. DIRECTIVES.



RESPONSIBLE PERSON  
AND MANUFACTURER

STUART TURNER LIMITED  
HENLEY-ON-THAMES, OXFORDSHIRE  
RG9 2AD ENGLAND.

Signed .....  ..... Technical Director

Stuart Turner are an approved company to BS EN ISO 9001:2015



Stuart Turner Ltd, Henley-on-Thames, Oxfordshire RG9 2AD ENGLAND

Tel: +44 (0) 1491 572655, Fax: +44 (0) 1491 573704

info@stuart-turner.co.uk www.stuart-turner.co.uk