

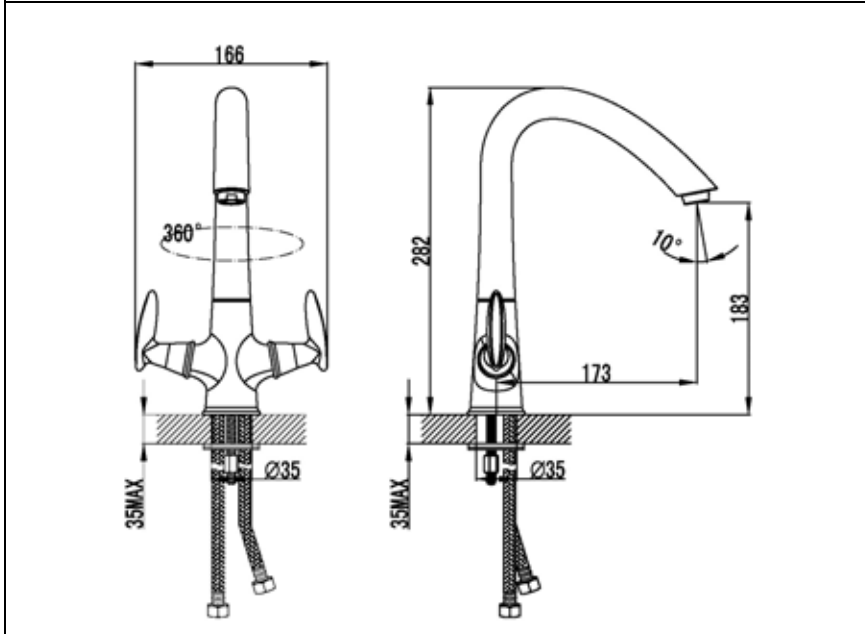

# SPUR ELEGANCE

## 92110 – SINK MIXER

# COMAP



Specification	
Finish	Chrome
Body	Brass
Fittings	Metal plate, washer, stud & locking nut
Connection	M10 – DN8 flexible hoses with 15mm compression ends
Min dynamic pressure	0.1
Max dynamic pressure	5
Max static pressure	10
Max water temperature	65°C

Flow rates				
Pressure	0.1	0.5	1	3
L/min	2.6	7.5	10.7	20

All Pressures are in Bar.  
 Dimensions supplied are nominal and subject to tolerance.  
 Inclusion of aerator (if supplied) or restrictors (sold separately unless stated) will affect flow rate result.  
 Performance details are based on trials under test conditions and for guidance only.  
 The Company reserves the right to change product specification without prior notice.

### Features & Benefits

 10 YEAR Guarantee	 L Low Pressure	 Flexible Hose	 Superfix
 Flow Aerator	 Single Flow		

### Certifications

 3.4 l/min	
Tested at 0.2 bar	