

Installation and Service Manual

Unvented Direct and Indirect hot water cylinder range

ASSURE SystemReady

125 - 300

Important

Please read & understand all these instructions before commencing installation.
Please leave this manual with the Customer for future reference

Contents

1. Introduction	3	7. Commissioning	21
1.1 General	3	7.1 General	21
1.2 Symbols used	3	7.2 Checklist before commissioning	21
1.3 Abbreviations	3	7.3 Commissioning procedure	21
1.4 Liabilities	3	8. Operation	22
2. Safety	4	8.1 General	22
2.1 General safety warnings	4	9. Maintenance	22
2.2 Recommendations	4	9.1 General	23
2.3 Specific safety instructions	4	9.2 Standard inspection & maintenance operations	23
3. Technical specifications	5	10. Troubleshooting	24
3.1 Technical data	5	10.1 Fault finding	24
3.2 Dimensions	6	11. Decommissioning	25
3.3 Electrical diagram(s)	7	11.1 Decommissioning procedure	25
4. Description of the product	9	12. Spare parts	25
4.1 General description	9	12.1 Spare parts list	25
4.2 Operation principle	9	Benchmark checklist	30
4.3 Main components	9	Commissioning & service records	31
4.4 Standard delivery	9		
5. Before installation	9		
5.1 Installation regulations	9		
5.2 Installation requirements	9		
5.3 Choice of location	10		
6. Installation	11		
6.1 General	11		
6.2 Water connections	12		
6.3 Electrical connections	20		
6.4 Filling the installation	20		



The HWA Charter's Code of Practice requires that all members adhere to the following:

- To supply fit for purpose products clearly and honestly described
- To supply products that meet, or exceed appropriate standards and building and water regulations
- To provide pre and post sales technical support
- To provide clear and concise warranty details to customers



THE BENCHMARK SCHEME

Benchmark places responsibilities on both manufacturers and Installers. The purpose is to ensure that Customers are provided with the correct equipment for their needs, that it is installed, commissioned and serviced in accordance with the manufacturer's instructions by competent persons and that it meets the requirements of the appropriate Building Regulations and relevant electrical qualifications. The Benchmark Checklist can be used to demonstrate compliance with Building Regulations and should be provided to the Customer for future reference. Installers are required to carry out installation, commissioning and servicing work in accordance with the Benchmark Code of Practice which is available from the Heating and Hotwater Industry Council who manage and promote the Scheme. Visit www.centralheating.co.uk for more information.

1. Introduction

1.1 General

The following instructions are offered as a guide to the user and Installer.

The installation must be carried out by a competent plumbing and electrical Installer in accordance with Building Regulation G3 (England and Wales), Technical Standard P3 (Scotland) or Building Regulation P5 (Northern Ireland) and the Water Fitting Regulations (England and Wales) or Water Byelaws (Scotland).

1.2 Symbols used

In these instructions, various risk levels are employed to draw the user's attention to particular information. In doing so we wish to safeguard the user, avoid hazards and guarantee the correct operation of the appliance.



DANGER

Risk of a dangerous situation causing serious physical injury.



WARNING

Risk of dangerous situation causing slight physical injury.



CAUTION

Risk of material damage.



Signals important information.

1.3 Abbreviations

- ▶ T&P - Temperature & Pressure relief valve
- ▶ PRV - Pressure Reducing Valve
- ▶ Prv - Pressure relief valve

1.4 Liabilities

Manufacturers liability

Our products are manufactured in compliance with the requirements of the various applicable European Directives.

This appliance complies with the requirements of the CE marking directive.

In the interest of our customers, we are continuously endeavouring to make improvements in product quality. All the specifications stated in this document are therefore subject to change without notice.

Our liability as the manufacturer may not be invoked in the following cases:

- ▶ Failure to abide by the instructions on using the appliance.
- ▶ Faulty or insufficient maintenance of the appliance.
- ▶ Failure to abide by the instructions on installing the product.

Installer's liability

The Installer is responsible for the installation and the commissioning of the appliance. The Installer must respect the following instructions:

- ▶ Read and follow the instructions given in the manuals provided with the appliance.
- ▶ Carry out installation in compliance with the prevailing legislation and standards.
- ▶ Perform the initial start up and carry out any checks necessary.
- ▶ Complete the commissioning checklist.
- ▶ Explain the installation to the user.
- ▶ If maintenance is necessary, warn the user of the obligation to check the appliance and maintain it in good working order.
- ▶ Give all the instruction manuals to the user.

Users liability

To guarantee optimum operation of the appliance, the user must respect the following instructions:

- ▶ Read and follow the instructions given in the manuals provided with the appliance.
- ▶ Call on qualified professionals to carry out installation and initial start up.
- ▶ Get your fitter to explain your installation to you.
- ▶ Have your required checks and services done.
- ▶ Keep the instruction manuals in good condition and close to the appliance.



This appliance can be used by children aged from 8 years and above and persons with reduced physical sensory or mental capabilities or lack of experience and knowledge if they have been given supervision or instruction concerning use of the appliance in a safe way and understand the hazards involved. Children shall not play with the appliance. Cleaning and user maintenance shall not be made by children without supervision.

Children must be supervised to ensure they do not play with the appliance.



- Water may drip from the discharge pipe of the pressure-relief device and this pipe must be left open to the atmosphere; (see page 19 for more details)

-The pressure-relief device is to be operated regularly to remove lime deposits and to verify that it is not blocked; (see page 19 for more details)

- How hot water can be drained. (see page 23 for more details)

- The type or characteristics of the pressure-relief device and how to connect it; (see Figure 6, page 11 for details and Figure 10, page 14)

- A discharge pipe connected to the pressure-relief device is to be installed in a continuously downward direction and in frost free environment; (see page 19 for details)

Details on how to set the temperature controls for both immersion heaters and boiler controls can be found in section "Installation Instructions, Figure 14, page 21.

2. Safety

2.1 General safety warning.



DANGER

This cylinder is unvented and as such becomes pressurised when in operation. The combination of pressurisation and hot water could lead to serious physical injury if the safety instructions in this manual are not adhered to.



WARNING

- ▶ Only competent persons having received adequate training are permitted to work on the appliance and the installation.
- ▶ Do not tamper with any of the safety valves or controls supplied with the cylinder.
- ▶ Before any work, switch off the mains supply to the appliance and the water mains.
- ▶ Do not switch on if there is a possibility that the water in the cylinder is frozen.



CAUTION

Do not operate immersion heaters until the cylinder has been filled with water.



WARNING

When handling the unit, take appropriate precautions for the weight of the unit. Weights can be found in section 3, table 1, page 5.



CAUTION

Annual maintenance by a competent person is recommended.



WARNING

- ▶ If water discharges from the temperature/pressure relief valve on the cylinder shut down the boiler/immersion heaters. Do not turn off any water supply. Contact a competent Installer for unvented water heaters to check the system.
- ▶ Do not tamper with any of the safety valves fitted to the system. If a fault is suspected contact a competent Installer.
- ▶ DO NOT bypass the thermal cut-out(s) in any circumstances.
- ▶ Where the inlet supply to the Pressure Reducing Valve is routed through a heated space and is fitted with a check valve or other fitting that would prevent back flow, high pressures can be experienced in the inlet pipe due to warming that can cause damage to the PRV or other fittings on the inlet supply. In these circumstances, the installation of a means to accommodate expansion and thus limit the pressure rise in the inlet pipe is recommended

3. Technical specifications

3.1 Technical data:

		125sb	145sb	170sb	210sb	250sb	300sb
Max direct kW rating		3	3	3	3	3	3
Immersion heat up times (Btm immersion, 3kW)		139	167	179	208	252	294
Coil surface area (m ²)		0.58	0.72	0.79	0.79	0.79	0.79
Primary Coil heat up times	15l/min	21.9	23.2	31.5	32.0	40.1	42.3
	30l/min	17.4	20.0	25.1	25.3	34.6	35.5
	45l/min	15.3	17.0	23.3	24.1	26.8	33.1
Coil rating (kW) ²	15l/min	19.5	20.9	19.4	19.4	19.5	20.5
	30l/min	25.1	25.0	25.1	25.3	24.2	25.4
	45l/min	27.8	28.8	26.8	26.8	28.9	28.3
Pressure drop through coil	15l/min	0.005 MPa (0.05 bar)					
	30l/min	0.018 MPa (0.18 bar)					
	45l/min	0.030 MPa (0.30 bar)					
Heat loss (kWh/24hrs)		1.05	1.18	1.20	1.42	1.61	1.69
Hot water capacity (volume to >40°C)		139	159	197	200	240	284
Weight empty (kg)		43	48	52	55	61	69
Weight full (kg) ¹		180	203	230	250	294	235
Volume (Litres) ¹		137	155	178	195	233	283
Max supply pressure		1.6 MPa (16 bar)					
Max design pressure		0.8 MPa (8 bar)					
Max operating pressure		0.3 MPa (3 bar)					
Max primary pressure		0.3 MPa (3 bar)					
Expansion relief valve setting		0.8 MPa (8 bar)					
T&P valve setting		1.0 MPa (10 bar)/90°C					
T&P Part number		95 605 810					
Immersion heater electrical rating		3.0kW@240V/2.8kW@230V ~					

Table 1: Technical data - Indirect

Notes:

1. Indirect cylinders tested in accordance with BS EN 12897:2006.
2. Heat up time from cold through 45°C, based on a flow temperature of 80°C +/- 2°C & normal volume.

Model(s)	125i	145i	170i	210i	250i	300i
Energy efficiency class	B	B	B	B	C	C
Storage volumes V in Litres	137.0	155.0	178.0	195.0	233.0	283.0
Standing loss in W	44.0	49.0	50.0	59.0	67.0	70.0

Table 2: Technical parameters in accordance with European Commission regulations 814/2013 and 812/2013

3.2 Dimensions and connections

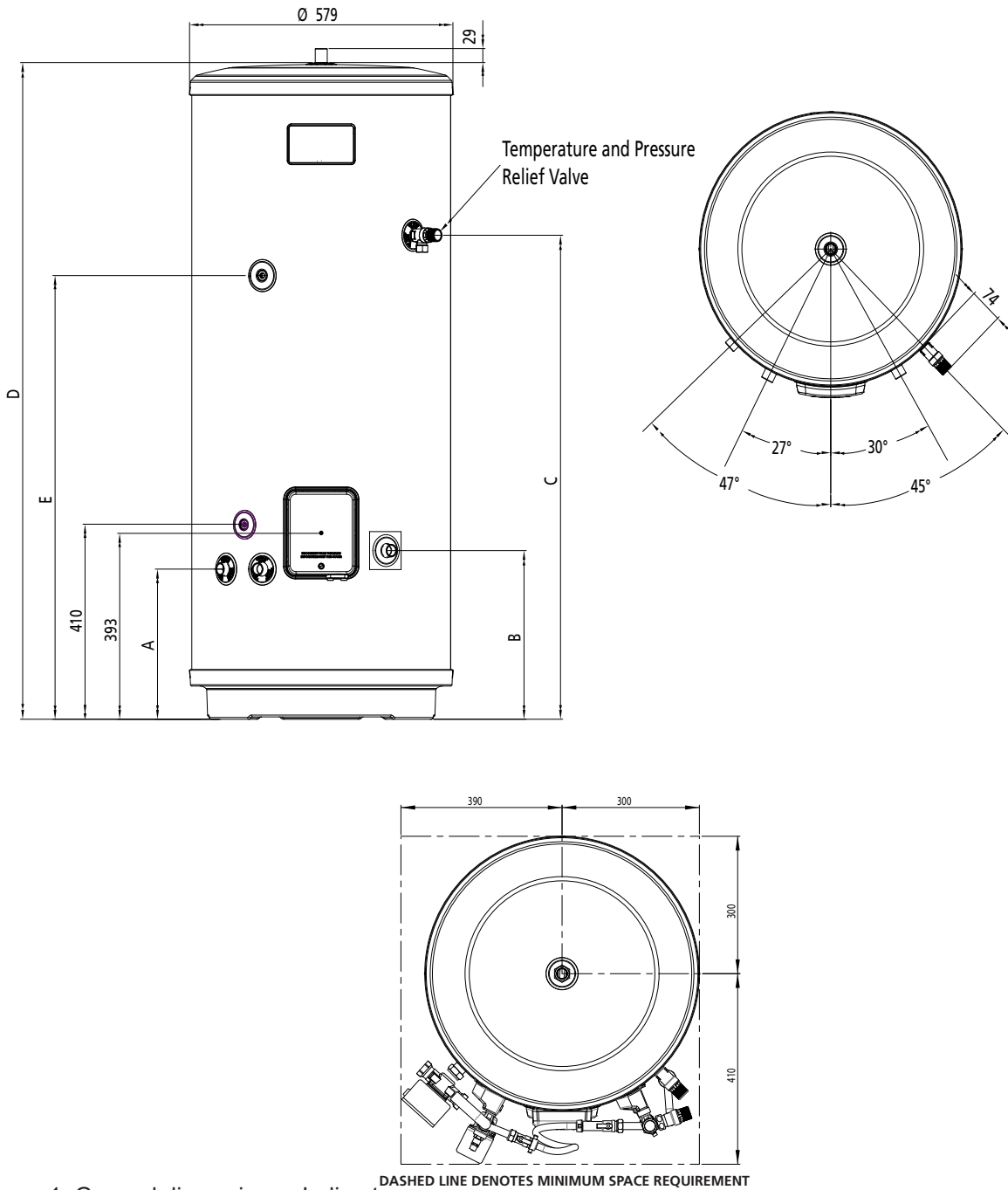
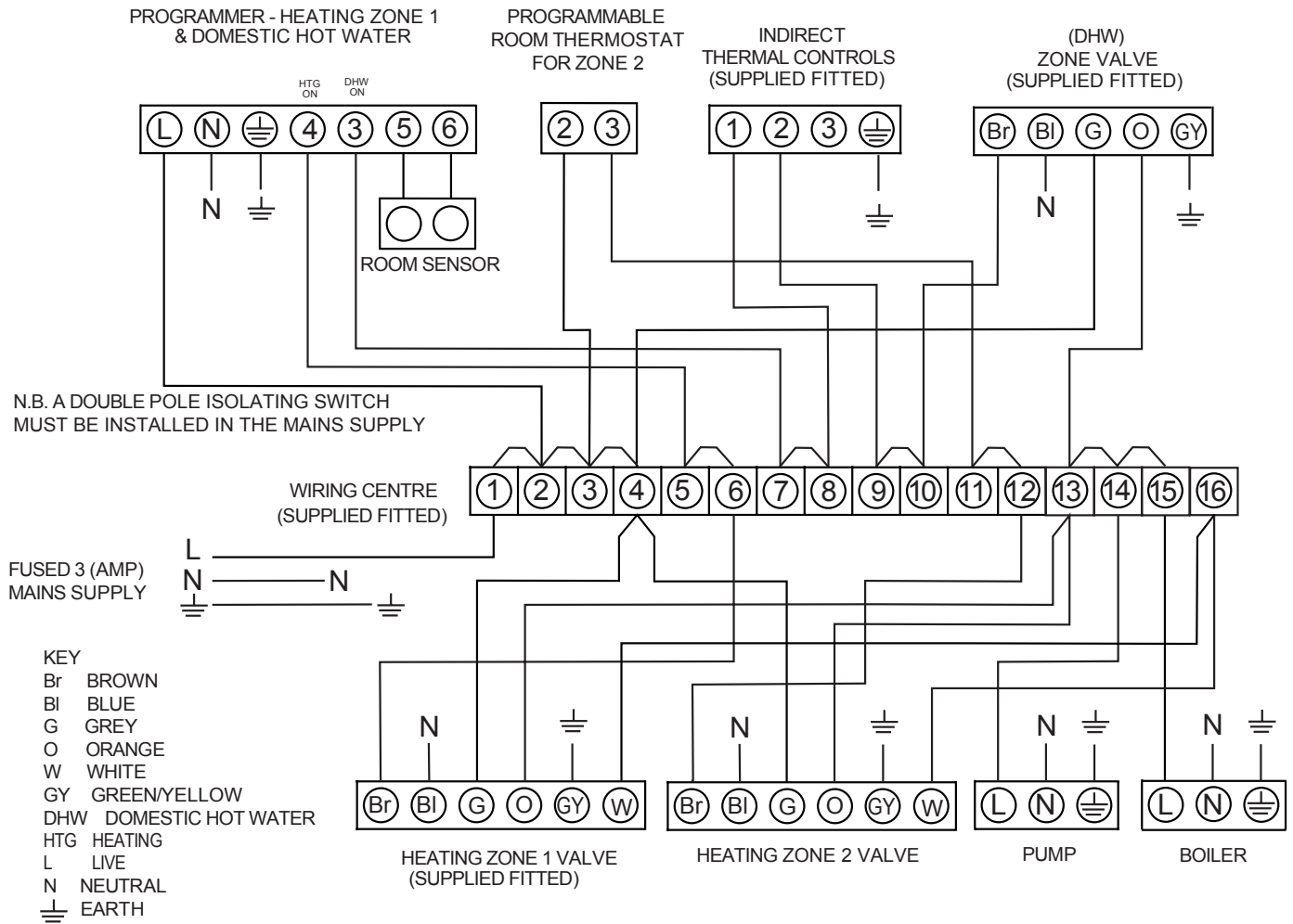

Figure 1: General dimensions - Indirect

SIZE	TYPE	DIMENSIONS (mm)				
	INDIRECT	A	B	C	D	E
125L	SB	316	355	794	1102	709
145L	SB	316	355	895	1229	810
170L	SB	316	355	1020	1384	934
210L	SB	316	355	1095	1486	1011
250L	SB	316	355	1323	1738	1238
300L	SB	316	355	1574	2053	1526

Table 3: General dimensions - Indirect

3.3 Electrical diagram



NOTES

1. ALL EARTH CONNECTIONS MUST BE LINKED BACK TO THE EARTH TERMINALS IN THE WIRING CENTRE
2. ALL NEUTRAL CONNECTIONS MUST BE LINKED BACK TO THE NEUTRAL TERMINALS IN THE WIRING CENTRE
3. ASSUMES BASIC BOILER
4. THE 22MM MOTORISED VALVES DO NOT HAVE A WHITE WIRE
5. THE ABOVE DIAGRAM IS FOR GUIDANCE ONLY. THE MANUFACTURER ACCEPTS NO LIABILITY FOR ANY LOSS OR DAMAGE ARISING FROM ANY ERRORS OR OMISSIONS THAT MAY BE INADVERTENTLY CONTAINED WITHIN THIS DIAGRAM. THE VARIOUS EQUIPMENT MANUFACTURERS SHOULD BE CONSULTED TO CONFIRM THE CORRECT OPERATION OF THEIR PRODUCTS WITHIN THE SYSTEM

Figure 2: Schematic wiring diagram - basic 2 x 2 port valve system

Access to Control Unit:

Disconnect from mains supply before removing any covers.

Removing the Control Cover.

- ▶ Unscrew the large screw using a flat ended screw driver.
- ▶ Lift from bottom of cover at point indicated until cover comes away freely.

Replacing the Control Cover:

- ▶ Tilt and align the top 2 lugs in the holes indicated.
- ▶ Firmly press the cover until it "snaps" back in place.
- ▶ Tighten the large screw.



WARNING

- ▶ Do not over tighten

Control Housing Details

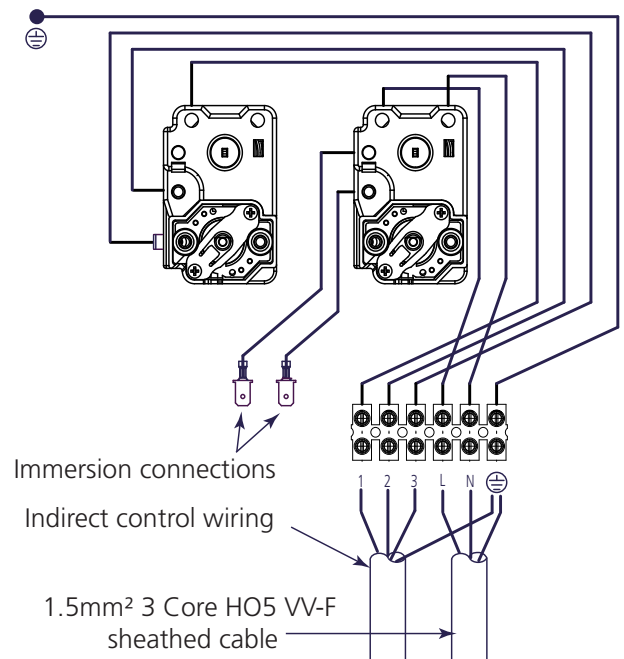

Figure 4: Indirect wiring schematic

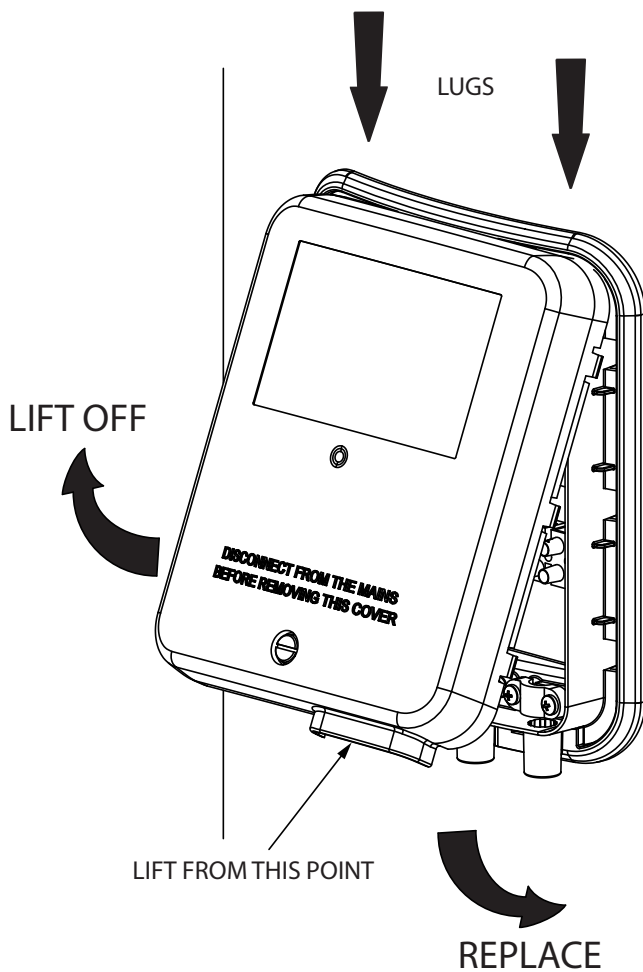

Figure 3: Cover Access

Direct Wiring Layout

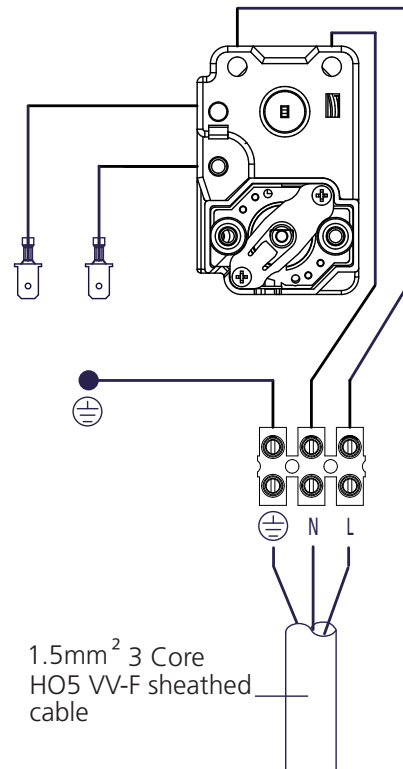

Figure 5: Direct wiring schematic

4. Description of the product

4.1 General description

This product is a purpose designed unvented water heater. The unit has a stainless steel inner vessel, which ensures an excellent standard of corrosion resistance. The outer casing is a combination of resilient thermoplastic mouldings and pre-coated steel. All products are insulated with CFC free polyurethane foam to give good heat loss protection.

The unit is supplied complete with all the necessary safety and control devices needed to allow connection to the cold water mains. All these components are preset and should not be tampered with.

4.2 Operation principle

The unvented cylinder is used to heat and store hot water for use in domestic.

Depending on the model the water can be heated directly using Immersion heater(s) or indirectly through a coil in the unit using an indirect heat source.

4.3 Main connections

See Figures 6 : Main connections on page 11

4.4 Standard delivery

The delivery includes:

- ▶ Cylinder
- ▶ Factory fitted
 - Immersion heater(s) and thermal controls
 - Temperature and Pressure Relief Valve (set at 90°C / 1 Mpa (10bar))
 - Indirect thermostat and thermal cut-out
 - 8 bar pressure relief valve (incorporating a check valve)
 - Tundish
 - T&P relief valve insulation set
 - Drain valve
 - Wiring centre
 - 2 x 2 Port motorised valve
 - Lock shield flow balancing valve
 - Filling Loop, straight
 - Drain valve (with quarter turn lever)
- ▶ Literature pack
 - Instructions (inc benchmark commissioning checklist & service record)
 - Fixing template
- ▶ 3 bar pressure reducing valve (incorporating strainer)
- ▶ Automatic air vent
- ▶ Isolating valve
- ▶ Lifting handle

4.5 Storage and Handling

If the unit is to be stored before installation it must be placed upright on a secure, level surface and be in a dry, frost free environment. The support surface must be capable of supporting the packaged weight of the unit, the packaged weights are displayed on the carton label.

Please take care when handling a packaged cylinder. The units are heavy and must only be moved manually using safe working practices. The package weights of each unit are displayed on the carton label. Once removed the units can be lifted by screwing the lifting handle provided onto the outlet boss, but again take note of the unit weights when deciding on a safe lifting method. DO NOT use the factory fitted T&P relief valve to lift or manoeuvre the unit.

5. Before installation

5.1 Installation regulations



WARNING

Installation of the appliance must be carried out by a qualified Engineer in accordance with prevailing and national regulations as listed below.

- ▶ Building Regulations G3
- ▶ The Building Standards (Scotland)
- ▶ The Building Regulations (Northern Ireland)
- ▶ I.E.E Electrical Regs
- ▶ UK Water Regulations

5.2 Installation requirements

Water supply

In an unvented system the pressure and flow rate is directly related to the incoming water supply. For this reason it is recommended that the maximum water demand is assessed and the water supply checked to ensure this demand can be satisfactorily met.

- ▶ We suggest the minimum supply requirements should be 0.15MPa (1.5 bar) pressure and 20 litres per minute flow rate. However, at these values outlet flow rates may be poor if several outlets are used simultaneously.
- ▶ A 22mm cold water supply is recommended, however, if a smaller supply exists, which provides sufficient flow, this may be used (although more flow noise may be experienced).
- ▶ The higher the available pressure and flow rate the better the system performance.
- ▶ See table 1 on page 5 for cylinder operating pressures. This is controlled by the cold water combination valve assembly.
- ▶ The water supply must be of wholesome water quality (Fluid Category 1 as defined by the Water Supply Regulations 1999).

- ▶ Where the inlet supply to the Pressure Reducing Valve is routed through a heated space and is fitted with a check valve or other fitting that would prevent back flow, high pressures can be experienced in the inlet pipe due to warming that can cause damage to the PRV or other fittings on the inlet supply. In these circumstances, the installation of a means to accommodate expansion and thus limit the pressure rise in the inlet pipe is recommended.

Outlet/terminal fittings (taps, etc.)

- ▶ The cylinder can be used with most types of terminal fittings.
- ▶ Outlets situated higher than the cylinder will give outlet pressures lower than that at the heater, a 10m height difference will result in a 1 bar pressure reduction at the outlet.
- ▶ All fittings, pipe work and connections must have a rated pressure of at least 8 bar (dependant on cylinder being fitted) at 80°C.

Limitations

The cylinder should not be used in association with any of the following:

- ▶ Solid fuel boilers or any other boiler in which the energy input is not under effective thermostatic control, unless additional and appropriate safety measures are installed.
- ▶ Ascending spray type bidets or any other class 1 back syphonage risk requiring that a type A air gap be employed.
- ▶ Steam heating plants unless additional and appropriate safety devices are installed.
- ▶ Situations where maintenance is likely to be neglected or safety devices tampered with.
- ▶ Water supplies that have either inadequate pressure or where the supply may be intermittent.
- ▶ Situations where it is not possible to safely pipe away any discharge from the safety valves.
- ▶ In areas where the water consistently contains a high proportion of solids, e.g. suspended matter that could block the strainer, unless adequate filtration can be ensured.
- ▶ In areas where the water supply contains chloride levels that exceed 250mg/l.
- ▶ Gravity circulation primaries.

5.3 Choice of location

The cylinder must be vertically floor mounted. Although location is not critical, the following points should be considered:

- ▶ The cylinder should be sited to ensure minimum dead leg distances, particularly to the point of most frequent use.
- ▶ Avoid siting where extreme cold temperatures will be experienced. All exposed pipe work should be insulated.
- ▶ The discharge pipe work from the safety valves must have minimum fall of 1:200 from the unit and terminate in a safe and visible position.
- ▶ Access to associated controls and immersion heaters must be available for the servicing and maintenance of the system. Where these controls are installed against a wall a minimum distance of 250mm must be left.
- ▶ Ensure that the floor area for the cylinder is level and capable of permanently supporting the weight when full of water (see table 1, page 5 for weights).
- ▶ Prior to installation the unit should be stored and transported in an area free from excessive damp or humidity. The Unit should be stored in a frost free environment.
- ▶ The tundish should be installed away from electrical components.

6. Installation

6.1 General

After reading the previous sections in this booklet and choosing a good location for the unit please install, paying attention to the following hydraulic, electrical and commissioning sections.

Boiler selection

- ▶ The boiler should have a control thermostat and non self-resetting thermal cut-out and be compatible with unvented storage water heaters.

- ▶ Can be a sealed system or open vented type - maximum primary pressure 10 bar.
- ▶ The primary flow from the boiler must be pumped. Gravity circulation will not work due to the special design of the primary heat exchanger. It is recommended that an air bleed point or automatic air vent is incorporated in the primary return pipe work close to the unvented system.
- ▶ The boiler cannot be vented through the cylinder.

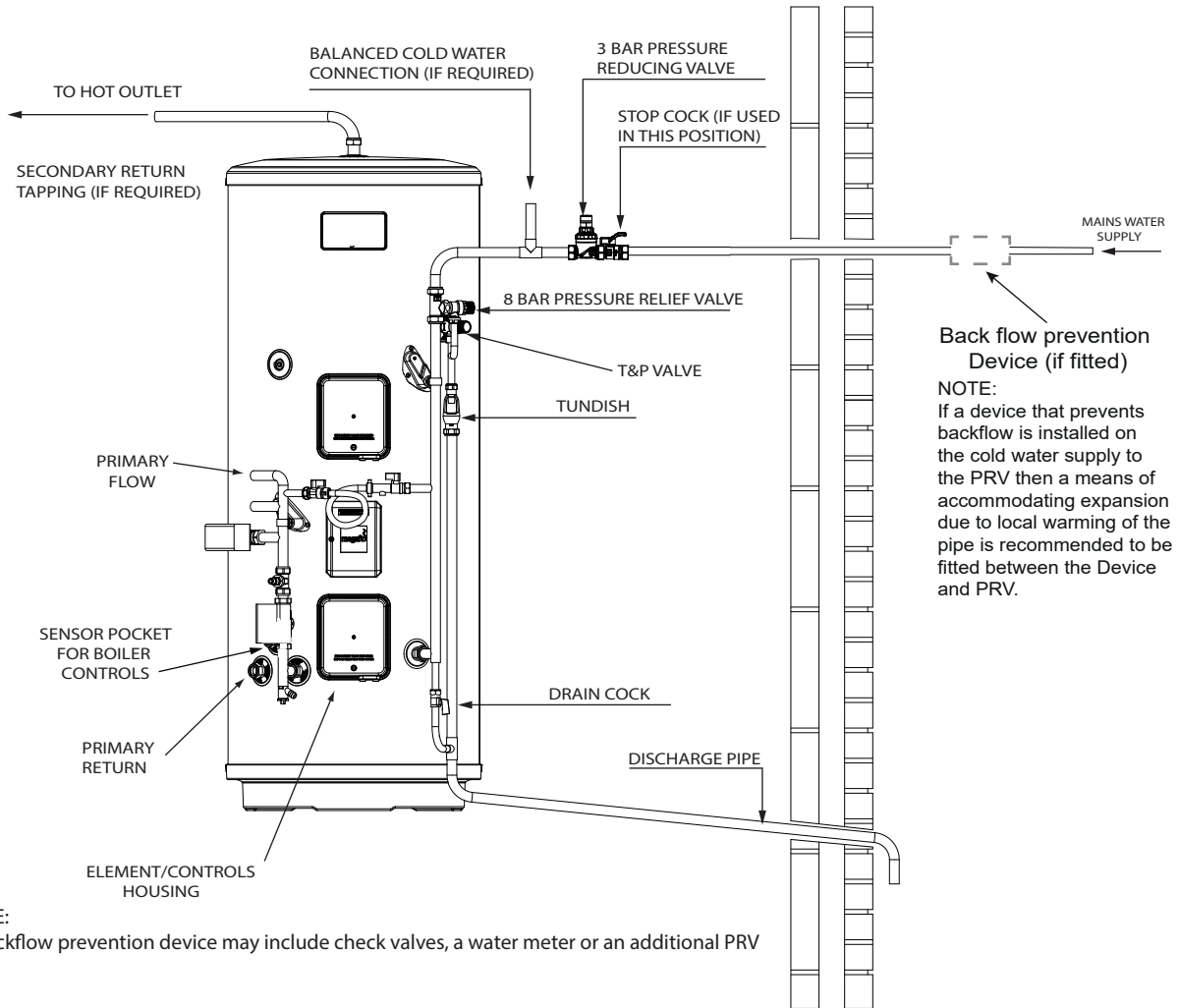

Figure 6: Typical installation schematic (not to scale)

6.2 Water connections



WARNING

- ▶ Under no circumstances should the factory fitted temperature/pressure relief valve be removed other than by a competent person. To do so will invalidate any warranty or claim.
- ▶ The cold water combination valve assembly must be fitted on the mains water supply to the cylinder.
- ▶ No control or safety valves should be tampered with or used for any other purpose.
- ▶ The discharge pipe should not be blocked or used for any other purpose.
- ▶ The tundish should not be located adjacent to any electrical components.

Refer to the installation schematic (fig 11, page 15) for details on the pipe work layout. Specific details for the discharge pipe work layout is also provided in figure 13 on page 19.

- ▶ The connection points to the heating system are in 22mm O/D copper pipe for 125, 145, 170, and 210 litre units.
- ▶ The connection points to the heating system are in 28mm O/D copper pipe for 250 and 300 litre units.
- ▶ All pipe fittings are made via 22mm compression fittings directly to the unit (nuts and olives supplied).
- ▶ Solder fittings can be used, but extreme care must be taken to ensure the plastic coating of the unit casing is not damaged by heat.
- ▶ Push fit type fittings can be used for connection to the copper pipes.
- ▶ The cold water inlet control kit supplied with the unvented unit incorporates a full flow isolating valve which will enable the unvented water heater to be isolated from the mains supply for maintenance or servicing..
- ▶ A suitable draining tap should be installed in the cold water supply to the cylinder between the expansion valve and the heater at as low a level as possible.
- ▶ It is recommended that the outlet point of the drain pipe work be at least 1 metre below the level of the heater (this can be achieved by attaching a hose to the drain tap outlet spigot).
- ▶ If the 2nd heating zone is not used, it is recommended that for the Installer to cap off the valve, using a correctly sized pipe end cap.

T&P Relief Valve Insulation

A set of insulating components is supplied with the water heater and should be installed to gain maximum heat and energy saving benefits. See Figure 7 below, for installation instructions.

IMPORTANT INFORMATION: HOW TO INSULATE YOUR T&P RELIEF VALVE

TO SAVE HEAT AND ENERGY A SET OF INSULATING PARTS FOR THE T&P RELIEF VALVE HAVE BEEN SUPPLIED WITH THIS WATER HEATER. INSTALL THE HEATER FIRST THEN FIT THE INSULATING PARTS BY FOLLOWING THE DIAGRAMS BELOW.

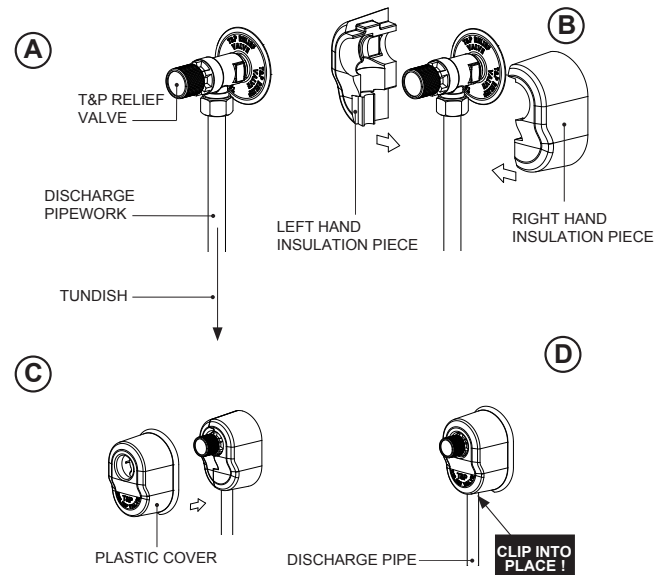

Figure 7: T&P insulation

Cold water control pack



CAUTION

- ▶ Flush supply pipe work before connection to remove all flux and debris prior to fitting the inlet controls. Failure to do this may result in irreparable damage to the controls and will invalidate any warranty.

- ▶ The 3 bar pressure reducing valve can be connected anywhere on the cold water cylinder supply. There is no requirement to site it close to the unit, it can be located at a point where the mains supply enters the premises if this is more convenient but you must install a non-return valve just after the reducing valve for ease of maintenance.
- ▶ The control pack incorporates the strainer, check valve, core unit and expansion relief valve.
- ▶ The pressure setting is set to 3 bar.
- ▶ The valve can be fitted in any orientation to suit the installation as long as the valve is installed with the direction of flow arrows pointing in the correct direction.

- ▶ The expansion relief valve should be installed with the discharge pipe work in either the horizontal position or facing downwards.
- ▶ No other valves should be placed between the cold water combination valve and the cylinder.
- ▶ Where discharge pipe work is difficult to attain, the local building control officer from the local council should be sought for advice as this falls under G3 guidelines and is not down to the manufacturer for unvented systems

Primary circuit control

- ▶ Primary circulation to the cylinder heat exchanger must be pumped; gravity circulation WILL NOT WORK.
- ▶ It is recommended that an air bleed or automatic air vent is incorporated in the primary return pipe work close to the unit.
- ▶ Boiler flow temperature should be set to 82° (maximum flow temperature to primary heat exchanger 88°C).

PRV WARNING:

IF THERE IS AN UPSTREAM CHECK VALVE OR FITTING WHICH MAY PREVENT BACKFLOW THEN HIGH PRESSURES CAN BE EXPERIENCED DUE TO AMBIENT TEMPERATURES WHICH CAN CAUSE DAMAGE TO THE VALVES AND FITTINGS

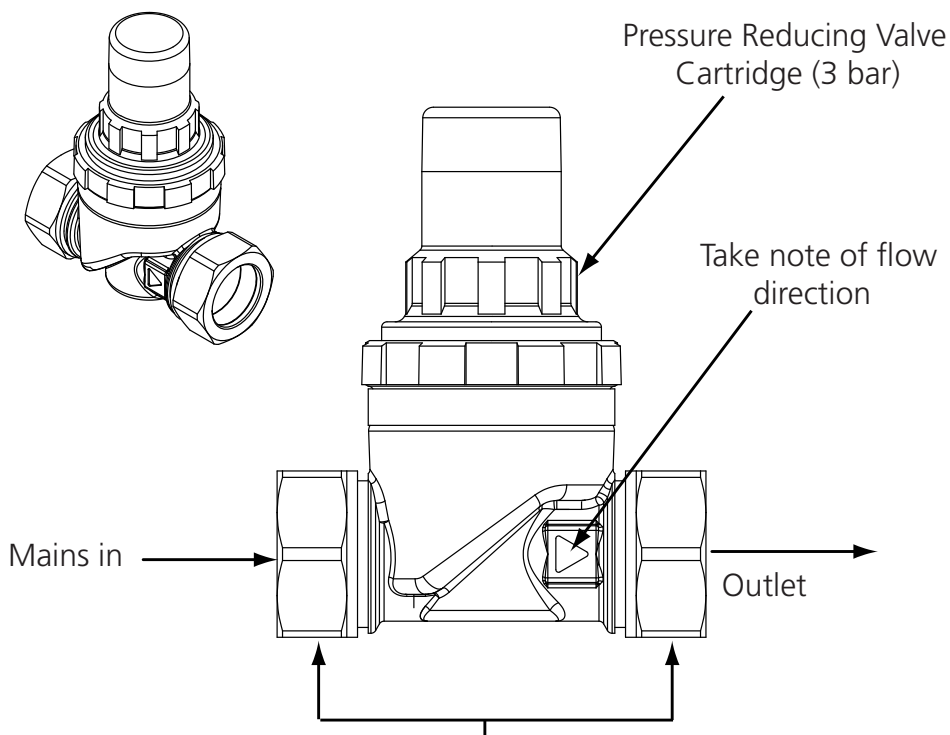

Figure 8: 3 bar pressure reducing valve

Stopcock is grouped with the 3 Bar pressure Reducing valve. Make sure the flow is correct to the markings on the valve.

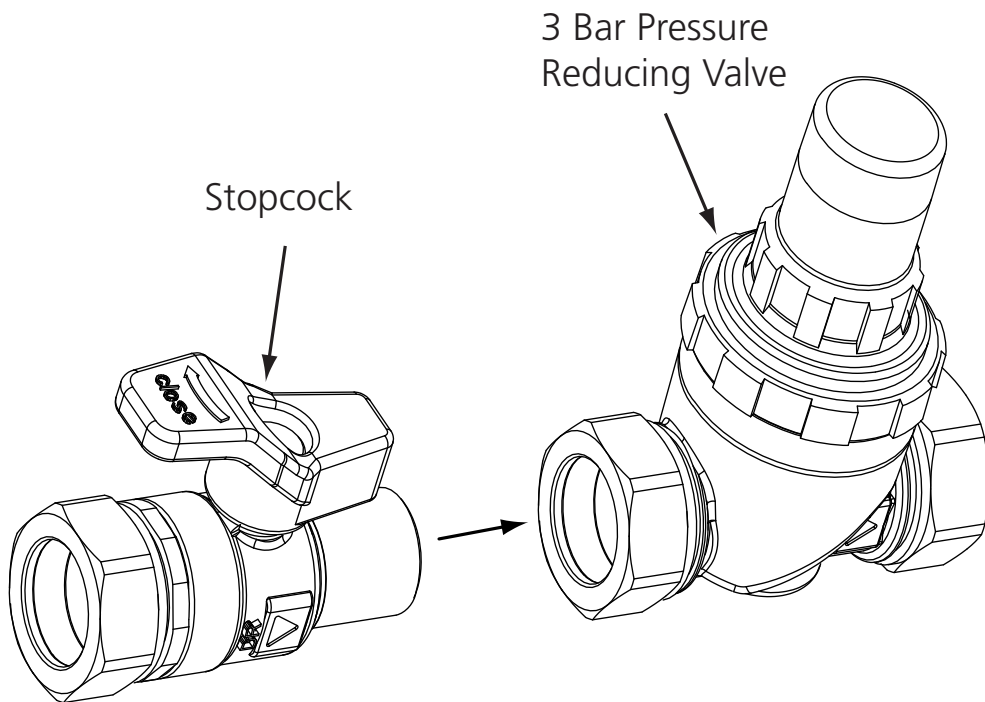

Figure 9: Stopcock and an 3 bar pressure relief valve

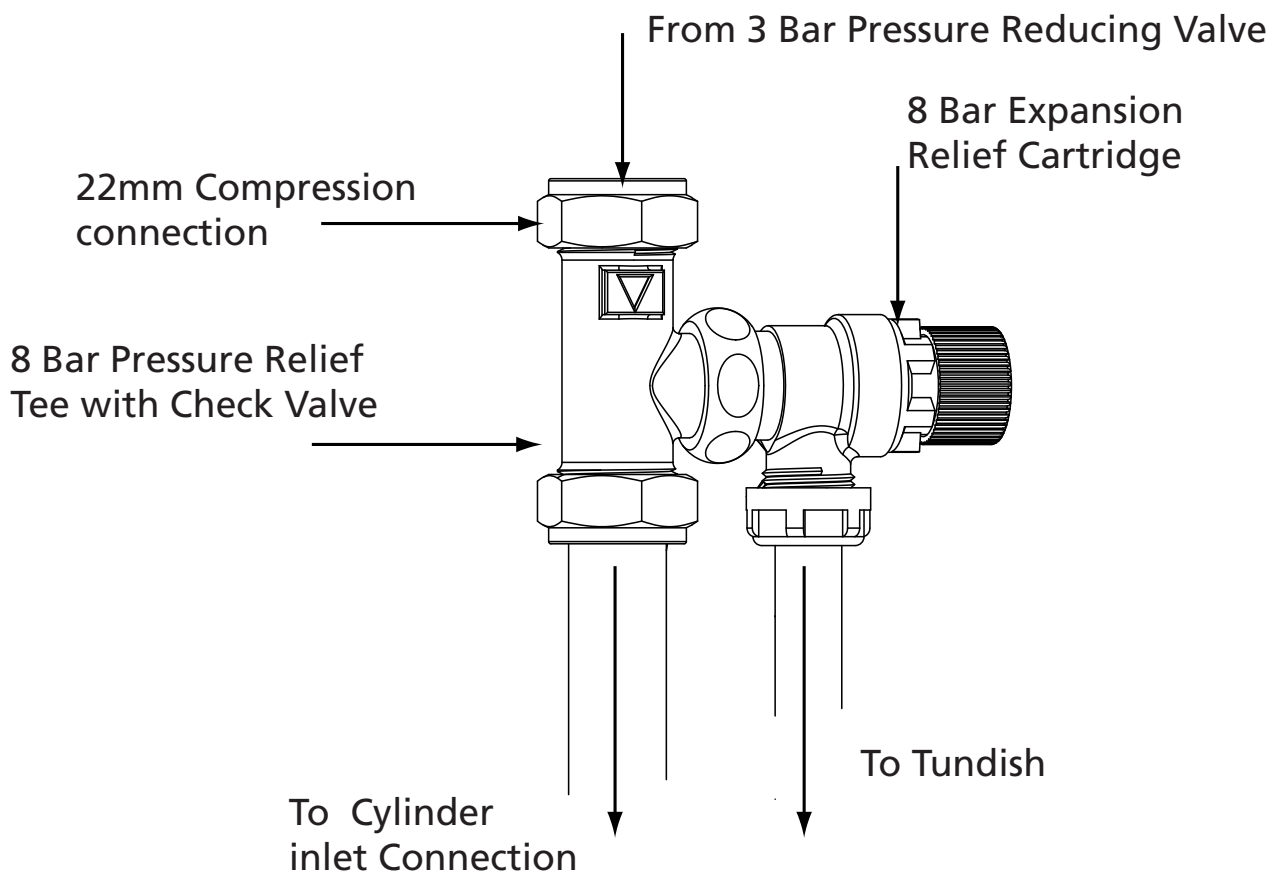

Figure 10: valve set can be grouped two ways

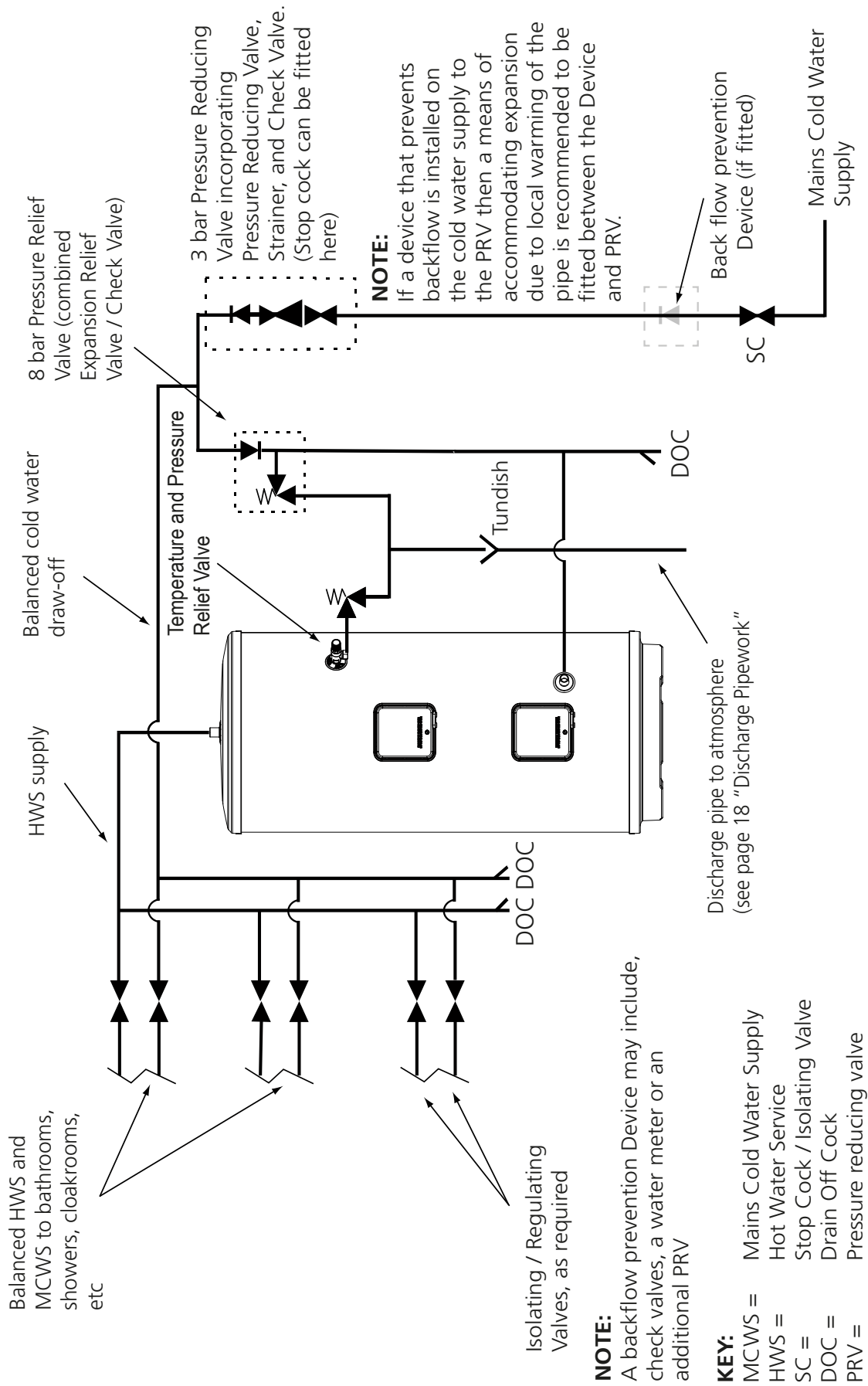

Figure 11: Schematic installation diagram using 3 bar pressure reducing valve in conjunction with 8bar pressure relief valve.

Secondary circulation

If secondary circulation is required it is recommended that it be connected to the cylinder as shown (see fig. 12, below).

- ▶ The secondary return pipe should be in 15mm pipe and incorporate a check valve to prevent back flow.
- ▶ A suitable WRAS approved bronze circulation pump will be required.
- ▶ On large systems, due to the increase in system water content, it may be necessary to fit an additional expansion vessel to the secondary circuit. This should be done if the capacity of the secondary circuit exceeds 10 litres.

Pipe capacity (copper):

15mm O.D. = 0.13 l/m (10 litres = 77m)

22mm O.D. = 0.38 l/m (10 litres = 26m)

28mm O.D. = 0.55 l/m (10 litres = 18m)

Note: Plastic pipe capacities may be reduced due to thicker wall sections.

i In direct electric installations where a secondary circulation is required particular attention should be paid by the Installer to maintain the returning water temperature (guidelines state that a minimum of 55°C return temperature is advisable). Factors such as, but not limited to, secondary circulation flow rates, minimising heat loss of all secondary circuit pipe work and timed operation during periods of high demand are critical to the correct operation and longevity of the heating element(s) and thermostats.

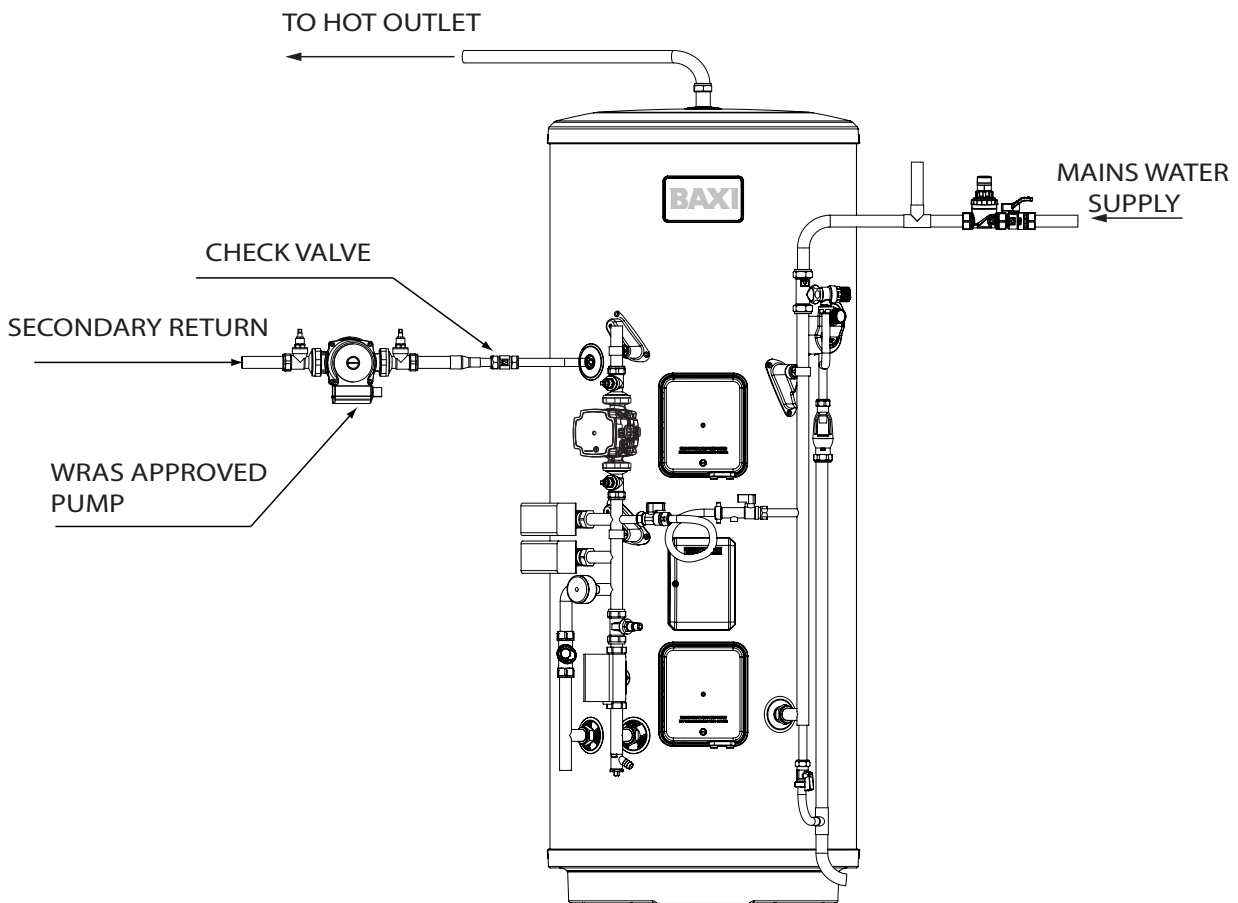

Figure 12: Secondary circulation schematic

Discharge

It is a requirement of Building Regulation G3 that any discharge from an unvented system is conveyed to where it is visible, but will not cause danger to persons in or about the building. The tundish and discharge pipes should be fitted in accordance with the requirements and guidance notes of Building Regulation G3. The G3 Requirements and Guidance section 3.50 - 3.63 are reproduced in the following sections of this manual. For discharge pipe arrangements not covered by G3 Guidance advice should be sought from your local Building Control Officer. Any discharge pipe connected to the pressure relief devices (expansion valve and temperature/pressure relief valve) must be installed in a continuously downward direction and in a frost free environment.

Water may drip from the discharge pipe of the pressure relief device. This pipe must be left open to the atmosphere. The pressure relief device is to be operated regularly to remove lime deposits and to verify that it is not blocked.

G3 REQUIREMENT

“...there shall be precautions...to ensure that the hot water discharged from safety devices is safely conveyed to where it is visible but will not cause danger to persons in or about the building.”

The following extract is taken from the latest G3 Regulations

Discharge pipes from safety devices

Discharge pipe D1

3.50 Each of the temperature relief valves or combined temperature and pressure relief valves specified in 3.13 or 3.17 should discharge either directly or by way of a manifold via a short length of metal pipe (D1) to a tundish.

3.51 The diameter of discharge pipe (D1) should be not less than the nominal outlet size of the temperature relief valve.

3.52 Where a manifold is used it should be sized to accept and discharge the total discharge from the discharge pipes connected to it.

3.53 Where valves other than the temperature and pressure relief valve from a single unvented hot water system discharge by way of the same manifold that is used by the safety devices, the manifold should be factory fitted as part of the hot water storage system unit or package.

Tundish

3.54 The tundish should be vertical, located in the same space as the unvented hot water storage system and be fitted as close as possible to, and lower than, the valve, with no more than 600mm of pipe between the valve outlet and the tundish (see fig 13).

Note: To comply with the Water Supply (Water Fittings) Regulations, the tundish should incorporate a suitable air gap.

3.55 Any discharge should be visible at the tundish. In addition, where discharges from safety devices may not be apparent, e.g. in dwellings occupied by people with impaired vision or mobility, consideration should be given to the installation of a suitable safety device to warn when discharge takes place, e.g. electronically operated.

Discharge pipe D2

3.56 The discharge pipe (D2) from the tundish should:

- (a) have a vertical section of pipe at least 300mm long below the tundish before any elbows or bends in the pipework (see fig. 13); and
- (b) be installed with a continuous fall thereafter of at least 1 in 200.

3.57 The discharge pipe (D2) should be made of:

- (a) metal; or
- (b) other material that has been demonstrated to be capable of safely withstanding temperatures of the water discharged and is clearly and permanently marked to identify the product and performance standard (e.g. as specified in the relevant part of BS 7291).

3.58 The discharge pipe (D2) should be at least one pipe size larger than the nominal outlet size of the safety device unless its total equivalent hydraulic resistance exceeds that of a straight pipe 9m long, i.e. for discharge pipes between 9m and 18m the equivalent resistance length should be at least two sizes larger than the nominal outlet size of the safety device; between 18 and 27m at least 3 sizes larger, and so on; bends must be taken into account in calculating the flow resistance. See Fig 13, Table 3 and the worked example.

Note: An alternative approach for sizing discharge pipes would be to follow Annex D, section D.2 of BS 6700:2006 Specification for design, installation, testing and maintenance of services supplying water for domestic use within buildings and their curtilages.

3.59 Where a single common discharge pipe serves more than one system, it should be at least one pipe size larger than the largest individual discharge pipe (D2) to be connected.

3.60 The discharge pipe should not be connected to a soil discharge stack unless it can be demonstrated that the soil discharge stack is capable of safely withstanding temperatures of the water discharged, in which case, it should:

- (a) contain a mechanical seal, not incorporating a water trap, which allows water into the branch pipe without allowing foul air from the drain to be ventilated through the tundish;
- (b) be a separate branch pipe with no sanitary appliances connected to it;

- (c) if plastic pipes are used as branch pipes carrying discharge from a safety device they should be either polybutylene (PB) to Class S of BS 7291-2:2006 or cross linked polyethylene (PE-X) to Class S of BS 7291-3:2006; and
- (d) be continuously marked with a warning that no sanitary appliances should be connected to the pipe.

Note:

1. Plastic pipes should be joined and assembled with fittings appropriate to the circumstances in which they are used as set out in BS EN ISO 1043-1.
2. Where pipes cannot be connected to the stack it may be possible to route a dedicated pipe alongside or in close proximity to the discharge stack.

Termination of discharge pipe

3.61 The discharge pipe (D2) from the tundish should terminate in a safe place where there is no risk to persons in the vicinity of the discharge.

3.62 Examples of acceptable discharge arrangements are:

- (a) to a trapped gully with the end of the pipe below a fixed grating and above the water seal;
- (b) downward discharges at low level; i.e. up to 100mm above external surfaces such as car parks, hard standings, grassed areas etc. are acceptable providing that a wire cage or similar guard is positioned to prevent contact, whilst maintaining visibility; and
- (c) discharges at high level: e.g. into a metal hopper and metal downpipe with the end of the discharge pipe clearly visible or onto a roof capable of withstanding high temperature discharges of water and 3m from any plastic guttering system that would collect such discharges.

3.63 The discharge would consist of high temperature water and steam. Asphalt, roofing felt and non-metallic rainwater goods may be damaged by such discharges.

Worked example of discharge pipe sizing

Fig. 13: shows a G1/2 temperature relief valve with a discharge pipe (D2) having 4 No. elbows and length of 7m from the tundish to the point of discharge.

From Table 3:

Maximum resistance allowed for a straight length of 22mm copper discharge pipe (D2) from a G1/2 temperature relief valve is 9.0m.

Subtract the resistance for 4 No. 22mm elbows at 0.8m each = 3.2m

Therefore the permitted length equates to: 5.8m

5.8m is less than the actual length of 7m therefore calculate the next largest size.

Maximum resistance allowed for a straight length of 28mm pipe (D2) from a G1/2 temperature relief valves equates to 18m.

Subtract the resistance of 4 No. 28mm elbows at 1.0m each = 4.0m

Therefore the maximum permitted length equates to: 14m

As the actual length is 7m, a 28mm (D2) copper pipe will be satisfactory.

Valve Outlet Size	Minimum Size Of Discharge Pipe D1	Minimum Size Of Discharge Pipe D2 From Tundish	Maximum Resistance Allowed, Expressed As A Length Of Straight Pipe (I.E. No Elbows Or Bends)	Resistance Created By Each Elbow Or Bend
G1/2	15mm	22mm 28mm 35mm	up to 9m up to 18m up to 27m	0.8m 1.0m 1.4m
G3/4	22mm	28mm 35mm 42mm	up to 9m up to 18m up to 27m	1.0m 1.4m 1.7m
G1	28mm	35mm 42mm 54mm	up to 9m up to 18m up to 27m	1.4m 1.7m 2.3m

Table 4: Sizing of copper discharge pipe (D2) for common temperature relief valve outlet sizes

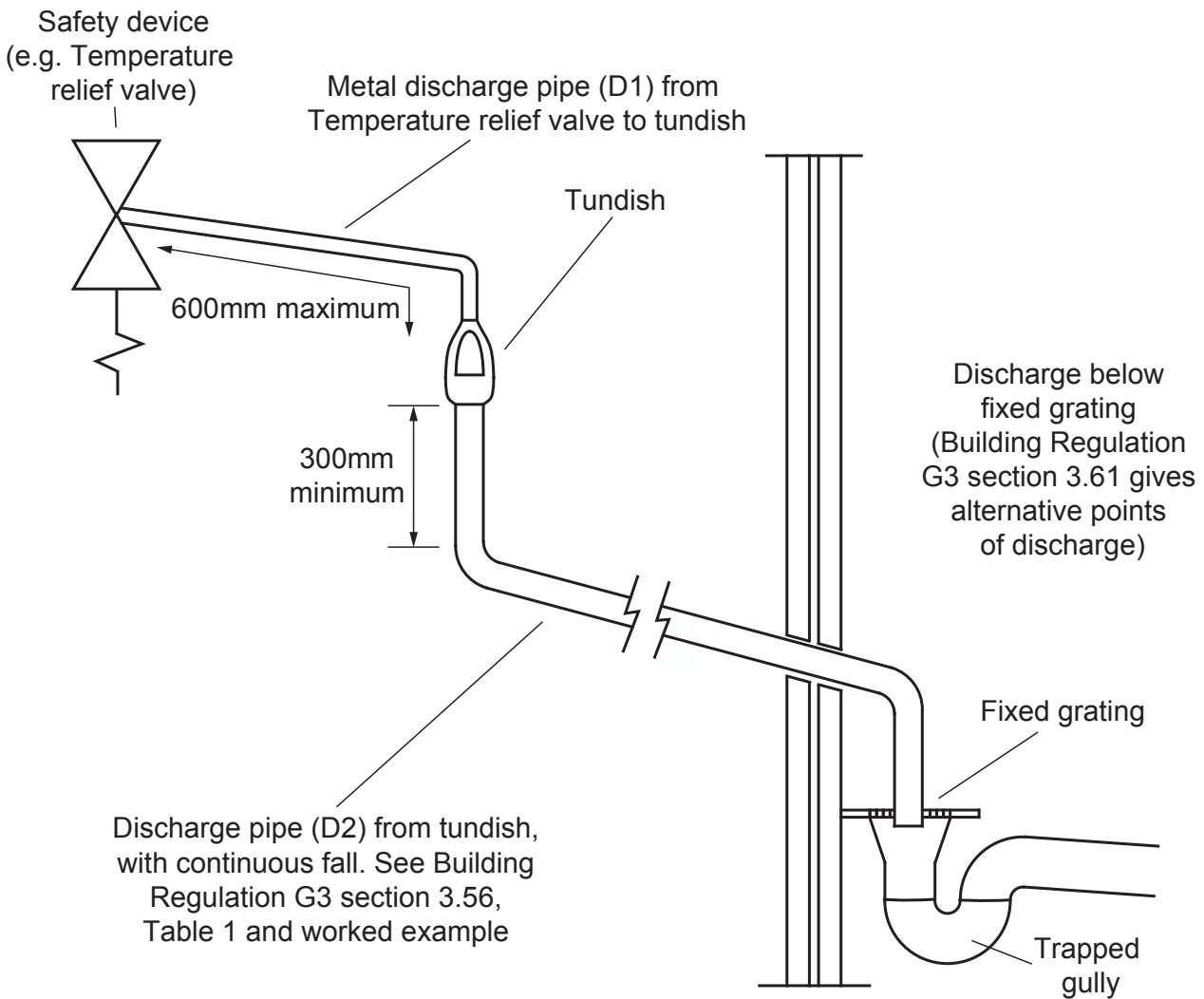

Figure 13: Typical discharge pipe arrangement (extract from Building Regulation G3 Guidance Section 3.50)

Notes:

- 1) Discharge pipe-work D2 can now be a plastic pipe but only pipes that have been tested to a minimum 110°C must be used.
- 2) Discharge pipe D2 can now be plumbed in the soil stack but only soil stacks that can handle temperatures of 99°C or greater should be used.

6.3 Electrical connections

In case of difficulty contact service support; contact details are available on page 36 of this booklet.



WARNING

- ▶ Disconnect from the mains electrical supply before removing any covers.
- ▶ Never attempt to replace the immersion heater(s) other than with genuine manufacturers components. Using other manufacturers components may invalidate the warranty on the cylinder.
- ▶ DO NOT bypass the thermal cut-out(s) in any circumstances. All electrical wiring should be carried out by a competent electrician and be in accordance with the latest I.E.E Wiring Regulations.
- ▶ Each circuit must be protected by a suitable fuse and double pole isolating switch with a contact separation of at least 3mm in both poles.
- ▶ DO NOT operate the immersion heaters until the cylinder has been filled with water.

- ▶ The immersion heater should be wired in accordance with Figs. 4 and 5, page 8.

Space and heating systems controls

- ▶ The controls provided with the cylinder will ensure the safe operation of the unit within the central heating system.
- ▶ Connections to the various system components is made via the wiring centre fitted to the front of the cylinder and the terminal identification labels within the wiring centre to aid in connecting the various external system components such as the mains supply, programmer and boiler.

6.4 Filling the installation

- ▶ Ensure the drain cock is CLOSED.
- ▶ Open a hot tap furthest from the cylinder.
- ▶ Open the isolating valve on the 3 bar pressure reducing valve by turning the blue handle on the stop cock (if fitted in this position) so that it lies parallel to the direction of flow.
- ▶ Open the mains stop cock to fill the unit. When water discharges from the tap, allow to run for a few minutes to thoroughly flush through any residue, dirt or swarf, then close the tap.
- ▶ Open successive hot taps to purge the system of air.



WARNING

Should the Assure cylinder be used in conjunction with a boiler that controls the water temperature via a sensor connected to the boiler controls it should be noted that the factory fitted indirect thermostat and thermal cut-out MUST NOT be disconnected or bypassed. To do so would invalidate the product approvals and warranty and it would not comply with Building Regulations. Should this method of control be adopted the Baxi Assure Indirect thermostat should be set at maximum and the boiler cylinder control temperature set at 60°C to avoid the thermostat over-riding the boiler control.

Where the boiler control does not directly power the 2 Port Motorised Valve supplied with the Baxi Assure, the wiring should ensure that in the event of the thermal cut-out on the Baxi Assure Indirect controls operating power will be interrupted to the 2 Port Motorised Valve such that it closes and prevents flow of the primary heating fluid around the Baxi Assure primary heat exchanger coil.

For further details of wiring the boiler, consult the boiler manufacturer's installation instructions.

7. Commissioning

7.1 General

After filling the installation with water in the previous section please follow the following steps to complete the installation of the unit.



WARNING

DO NOT operate the immersion heaters or primary circuit until the cylinder has been filled with water.

7.2 Checklist before commissioning

- ▶ Check all water connections for leaks and rectify as necessary.
- ▶ Turn off mains water supply.
- ▶ Remove the pressure reducing valve head work to access the strainer mesh, clean and re-fit.
- ▶ Turn the water supply back on.
- ▶ Manually open, for a few seconds, each relief valve in turn, checking that water is discharged and runs freely through the tundish and out at the discharge point.
- ▶ Ensure that the valve(s) re-seat satisfactorily.

7.3 Commissioning procedure

Direct Heating

- ▶ Switch on electrical supply to the immersion heater(s) and allow the cylinder to heat up to normal working temperature (60 - 65°C recommended).
- ▶ If necessary the temperature can be adjusted by inserting a flat bladed screwdriver in the adjustment spindle on front of the immersion heater thermostat and rotating. The adjustment represents a temperature range of 12°C to 68°C.
- ▶ Check the operation of thermostat(s) and that no water has issued from the expansion relief valve or temperature/pressure relief valve during the heating cycle.

Indirect units

- ▶ Fill the indirect (primary) circuit following the boiler manufacturer's commissioning instructions.
- ▶ Ensure the filling loop hose is connected at both ends and is tight.
- ▶ Open the isolating valves at either end of the filling loop and allow to fill from the mains inlet supply.
- ▶ To ensure the cylinder primary heat exchanger is filled, the 2 port motorised valve (supplied) should be manually opened by moving the lever on the motor housing to the MANUAL setting. When the primary circuit is full return the lever to the AUTOMATIC position.
- ▶ Air can be vented from the primary heating coil by unscrewing the small dust cap on the auto air vent by half a turn.
- ▶ The primary system should be pressurised to the minimum pressure required by the boiler (usually 1 bar).
- ▶ When full and pressurised, the filling loop isolating valves should be closed and the pipe disconnected. The levers on the motorised valves should be returned to the Auto position.
- ▶ Switch on the boiler, ensure the programmer is set to Hot Water and allow the cylinder to heat up to a normal working temperature (60 - 65°C recommended).
- ▶ Vent any trapped air, radiators and the boiler should be vented separately.



WARNING

- ▶ If the unit is to be left unused following installation and commissioning e.g. unoccupied properties, the water heater should be drained or regularly flushed through with fresh mains water once a week.
- ▶ When placing the unit into service, the procedure for filling the unit and the system checks above should be observed.

Figure 14: Boiler and Immersion controls

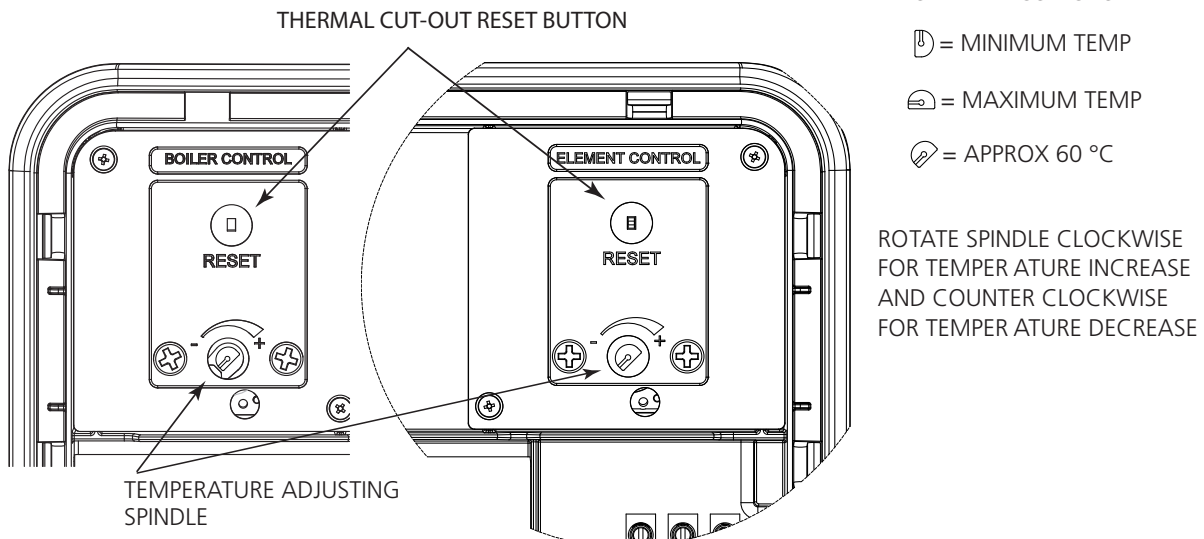

8. Operation

8.1 General

WARNING



- ▶ If water discharges from the temperature/pressure relief valve on the cylinder shut down the heat source. Do not turn off any water supply. Contact a competent Installer for unvented water heaters to check the system.
- ▶ Do not tamper with any of the safety valves fitted to the system. If a fault is suspected contact a competent Installer.
- ▶ DO NOT bypass the thermal cut-out(s) in any circumstances.

Benchmark

The cylinder is covered by the Benchmark Scheme which aims to improve the standards of installation and commissioning of domestic heating and hot water systems in the UK and to encourage regular servicing to optimise safety, efficiency and performance.

Benchmark is managed and promoted by the Heating and Hotwater Industry Council. For more information visit www.centralheating.co.uk.

Please ensure that the Installer has fully completed the Benchmark Checklist (page 30) of this manual and that you have signed it to say that you have received a full and clear explanation of its operation. The Installer is legally required to complete a commissioning checklist as a means of complying with the appropriate Building Regulations (England & Wales).

All installations must be notified to Local Area Building Control either directly or through a Competent Persons Scheme. A Building Regulations Compliance Certificate will then be issued to the Customer who should, on receipt, write the Notification Number on the Benchmark Checklist.

This product should be serviced regularly to optimise its safety, efficiency and performance. The service Engineer should complete the relevant Service Record on the Benchmark Checklist after each service.

The Benchmark Checklist may be required in the event of any warranty work.

Flow performance

When initially opening hot outlets a small surge in flow may be noticed as pressures stabilise. This is quite normal with unvented systems. In some areas cloudiness may be noticed in the hot water. This is due to aeration of the water, is quite normal and will quickly clear.

Operational faults and their possible causes are detailed in the Fault Finding section (page 24) of this book. It is recommended that faults should be checked by a competent Installer.

Temperature controls – direct units immersion heater(s)

- ▶ All immersion heaters are fitted with a thermostat which is fitted in the centre of the heater plate and a cut-out which is fitted to the side of the thermostat.
- ▶ Access to the thermostat can be made by opening the immersion heater cover - DISCONNECT THE ELECTRICAL SUPPLY BEFORE OPENING THE COVER(S).
- ▶ Temperature adjustment is made by rotating the adjustment knob on the top of the thermostat. The adjustment represents a temperature range of 12°C to 68°C.
- ▶ Maximum working temperature is 68°C/154°F. In very hard water areas limit to 60/65°C (140/150°F).

DO NOT bypass the thermal cut-out(s) in any circumstances.

Temperature controls - indirect units

The cylinder units are fitted with an indirect thermostat and thermal cut-out. These controls must be wired in series with the 2 port motorised zone valves supplied to interrupt the flow of primary water around the heat exchanger coil when the control temperature has been reached.

DO NOT bypass the thermal cut-out(s) in any circumstances.

The air volume within the product will periodically require recharging to ensure expanded water is accommodated within the system. A discharge of water INTERMITTENTLY from the expansion valve will indicate the air volume has reduced to a point where it can no longer accommodate the expansion.

INFO

<http://www.baxi.co.uk/information-and-advice/how-to-videos.htm>

To recharge the air volume:-

- ▶ Turn off the heat source to the cylinder via programmers / immersion isolation switch(es).
- ▶ Turn off the water supply to the cylinder by turning off the isolating valve on the 3 bar pressure reducing valve if fitted at this point or at the 8 bar pressure relief valve if fitted there. Turn the handle so that it lies at 90° to the direction of flow. See figure 17 page 26.
- ▶ Open the lowest hot tap.
- ▶ Hold open the temperature / pressure relief valve until water ceases to run from the tap and gurgling noise at the valve stops.
- ▶ Close the temperature / pressure relief valve.
- ▶ Turn on the isolating valve at the cold water combination valve by turning the handle so it lies parallel to the direction of flow, when water flows from the hot tap, close tap.
- ▶ The air volume will be automatically recharged as the unit refills. If after following the above actions water still discharges from the expansion relief valve, further advice should be sought from a competent Installer or Baxi Customer Support.

9. Maintenance

9.1 General

Maintenance requirements

Unvented hot water systems have a continuing maintenance requirement in order to ensure safe working and optimum performance. It is essential that the relief valve(s) are periodically inspected and manually opened to ensure no blockage has occurred in the valves or discharge pipework. Maintenance of this appliance should only be carried out by a suitably qualified person. Failure to do so could invalidate the warranty.

Similarly cleaning of the strainer element and replacement of the air in the product will help to prevent possible operational faults.

The maintenance checks described below should be performed by a competent person on a regular basis, e.g. annually to coincide with boiler maintenance.

After any maintenance, please complete the relevant Service Interval Record section of the Benchmark Checklist on page 30 of this document.

9.2 Standard inspection & maintenance operation

Inspection

The immersion heater boss can be used as an access for inspecting the cylinder internally.

Safety valve operation



CAUTION

Water discharged may be very hot!

- ▶ Manually operate the temperature/pressure relief valve for a few seconds.
- ▶ Check water is discharged and that it flows freely through the tundish and discharge pipe work.
- ▶ Check valve reseats correctly when released.
- ▶ Repeat the above procedure for the expansion relief valve.

Strainer

- ▶ Turn off the isolating valve prior to the Pressure Reducing Valve or the main stop cock to the system.
- ▶ Open the lowest hot tap in the system to relieve the system pressure.
- ▶ Using a spanner unscrew the pressure reducing cartridge and remove the moulded housing. The strainer will be removed with the cartridge.
- ▶ Wash any particulate matter from the strainer under clean running water.
- ▶ Replace the strainer and screw the Pressure Reducing Valve cartridge into the moulded housing.

- ▶ Close hot tap, turn on isolating valve or main stop cock to the system. Check for leaks.

Descaling immersion heater(s)

- ▶ Turn off the mains water supply, isolate the electrical supply and turn off boiler
- ▶ Attach a hosepipe to the drain cock having sufficient length to take water to a suitable discharge point below the level of the unit.
- ▶ Open a hot tap close to the unit and open drain cock to drain unit. If water fails to drain vent the unit manually by opening the temperature and pressure relief valve.
- ▶ Open the cover(s) to the immersion heater housing(s) and disconnect wiring from immersion heater(s) thermostat(s).
- ▶ Unscrew the immersion heater backnut(s) and withdraw the immersion heater from the cylinder. A key spanner is supplied with the product for easy removal and tightening of the immersion heater(s). Over time the immersion heater gasket may become stuck to the mating surface. To break the seal insert a round shafted screwdriver into one of the pockets on the immersion heater and gently lever up and down. Take care when lifting the immersion heater out of the cylinder and work within safe working practices.
- ▶ Carefully remove any scale from the surface of the element(s).



CAUTION

DO NOT use a sharp implement as damage to the element surface could be caused.

- ▶ Ensure sealing surfaces are clean and seals are undamaged, if in doubt fit a new gasket. (spare part number 7035165)
- ▶ Replace immersion heater(s), making sure not to trap the gasket.
- ▶ Rewire, check, close and secure immersion heater housing cover(s).

Re-commissioning

- ▶ Check all electrical and plumbing connections are secure. Close the drain cock.
- ▶ With a hot tap open, turn on the cold water supply and allow unit to refill.
- ▶ DO NOT switch on the immersion heater(s) or boiler until the unit is full.
- ▶ When water flows from the hot tap allow to flow for a short while to purge air and flush through any disturbed particles.
- ▶ Close hot tap and then open successive hot taps in system to purge any air.
- ▶ When completely full and purged check system for leaks.
- ▶ The heating source (immersion heater(s) or boiler) can then be switched on.

10. Troubleshooting



WARNING

Do not tamper with any of the safety valves or controls supplied with the cylinder as this will invalidate any warranty.

10.1 Fault finding

Important

- ▶ After servicing, complete the relevant Service Interval Record section of the Benchmark Checklist located on pages 30 and 31 of this document.
- ▶ Servicing should only be carried out by competent persons in the installation and maintenance of unvented water heating systems.
- ▶ Any spare parts used MUST be authorised parts.
- ▶ Disconnect the electrical supply before removing any electrical equipment covers.
- ▶ NEVER bypass any thermal controls or operate system without the necessary safety valves.

- ▶ Water contained in the cylinder may be very hot, especially following a thermal control failure. Caution must be taken when drawing water from the unit.

The fault finding chart (table 5, below) will enable operational faults to be identified and their possible causes rectified. Any work carried out on the unvented water heater and its associated controls MUST be carried out by a competent Installer for unvented water heating systems. In case of doubt contact service support.

Spare Parts

A full range of spare parts are available for the cylinder range (table 6, page 25). Refer to the technical data label on the unit to identify the model installed and ensure the correct part is ordered. You will need to quote the serial number, which is printed on the data label.

Fault	Possible Cause	Remedy
No hot water flow	Mains water supply off	Check and open stop cock
	Strainer blocked	Turn off water supply. Remove strainer and clean
	Cold water combination valve incorrectly fitted	Check and refit as required
Water from hot tap is cold	Direct immersion heater not switched on	Check and switch on
	Direct immersion heater thermal cut-out has operated	Check, reset by pushing button on thermostat
	Indirect programmer set to central heating only	Check, set to domestic hot water programme
	Indirect boiler not working	Check boiler operation. If fault is suspected consult boiler manufacturer's instructions
	Indirect thermal cut-out has operated	Check, reset by pushing button on thermostat. Check operation of indirect thermostat
Water discharges from expansion valve	Indirect motorised valve not connected correctly	Check wiring and/or plumbing connections to motorised valve
	Intermittently Air volume in product has reduced	See page 22 for re-charging of Air volume
Water discharges from expansion valve	Continually Cold water combination valve pressure reducer not working correctly. Expansion valve seat damaged	Check pressure from cold water combination valve. If greater than 3bar replace pressure reducing valve cartridge. Remove expansion valve cartridge, check condition of seat. If necessary fit new expansion valve
	Thermal control failure CAUTION: Water will be very hot!	Switch off power to immersion heater(s) and shut down boiler. DO NOT turn off water supply. When discharge stops check all thermal controls, replace if faulty
Milky water	Oxygenated water	Water from a pressurised system releases oxygen bubbles when flowing. The milky water will disappear after a short while

Table 5: Fault finding chart

11. Decommissioning

11.1 Decommissioning procedure

- ▶ Isolate electrical supplies and make safe
- ▶ Isolate the water supply
- ▶ Drain the cylinder
- ▶ Drain the primary circuit (indirect only)
- ▶ Remove cylinder
- ▶ Cap pipework

Environmental information

Products are manufactured from many recyclable materials. At the end of their useful life they should be disposed of at a Local Authority Recycling Centre in order to realize the full environmental benefits.

Insulation is by means of an approved CFC/HCFC free polyurethane foam with an ozone depletion factor of zero.

12. Spare parts

12.1 Spare parts list

A full range of spare parts are available for the cylinder range. Refer to the Technical Data label on the unit to identify the model installed and ensure the correct part is ordered.

DESCRIPTION	SPARES NUMBER
Cold water inlet control kit - complete	95605894
3 bar pressure reducing valve - complete	95605886
8 bar pressure relief valve - complete	95605893
Stopcock	95605885
Immersion heater backnut	95607940
Immersion heater gasket	7035165
Immersion heater key	95607861
Immersion heater blanking plug	95605881
Titanium immersion heater - upper	95606989
Direct combined thermostat / thermal cut-out	95612717
Direct combined thermostat / thermal cut-out (spade terminals)	95612720
Tundish	95605838
Insulation set (T&P relief valve)	95607922
Mounting plate (indirect)	95607931
Indirect control cover	95614118
6 way terminal block	95607933
2 port motorised valve (22mm connections)	95605819
Incoloy immersion heater - lower	95606984
Indirect combined thermostat and cut-out	95612716
Indirect combined thermostat and cut-out (spade terminals)	95612719
Temperature and pressure relief valve	95605810
Set of compression nuts and olives	95607838
Drain valve 1/4 turn	95605051
Wiring centre	95612702
Automatic differential bypass valve (straight)	95607692
2 port motorised valve (28mm connections)	95605884
Automatic air vent	95605050
Filling loop and connection	95607096
22mm Manifold	7728889
28mm Manifold	7728890
1/2" BSP Sensor Pocket Assembly Long	7032579

Table 6: Spares

Figure 15: Exploded view of 3 bar pressure reducing valve

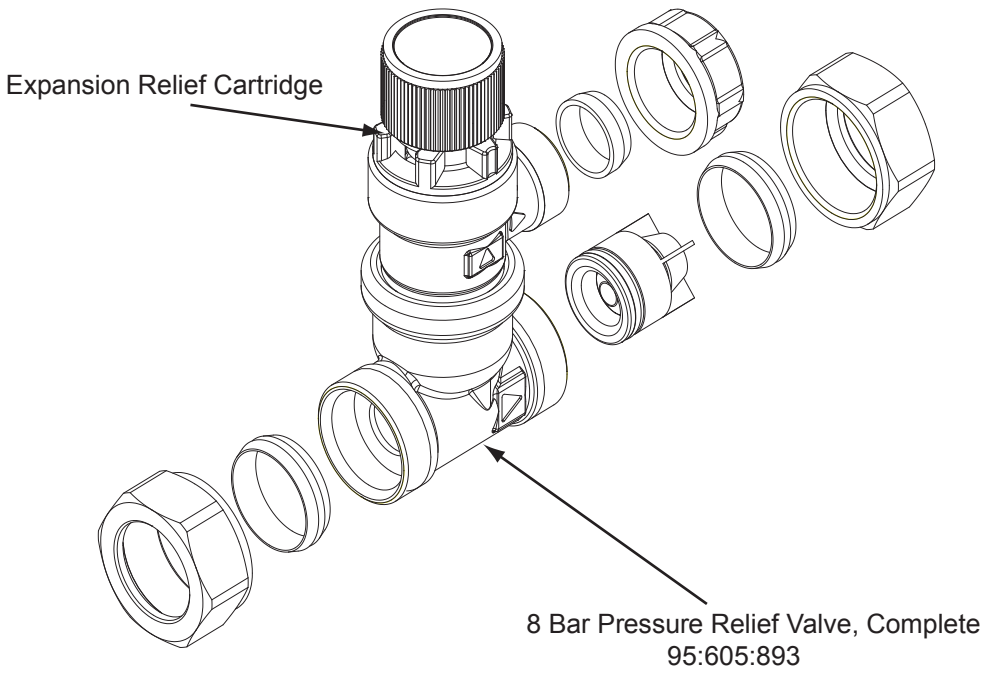
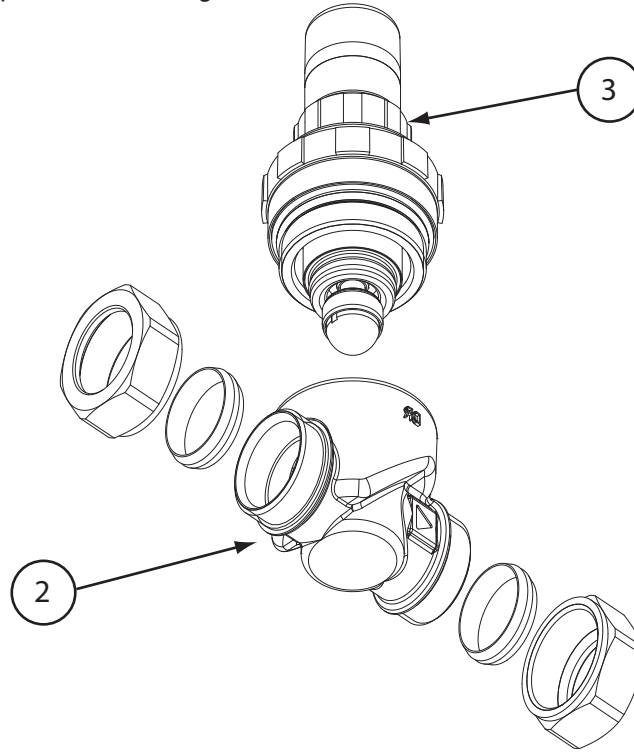

Figure 16: Exploded view of 8 bar pressure relief valve

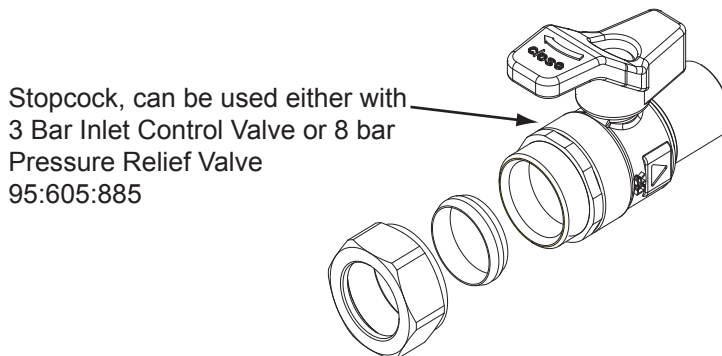

Figure 17: Exploded view of stopcock

Indirect Control Assembly

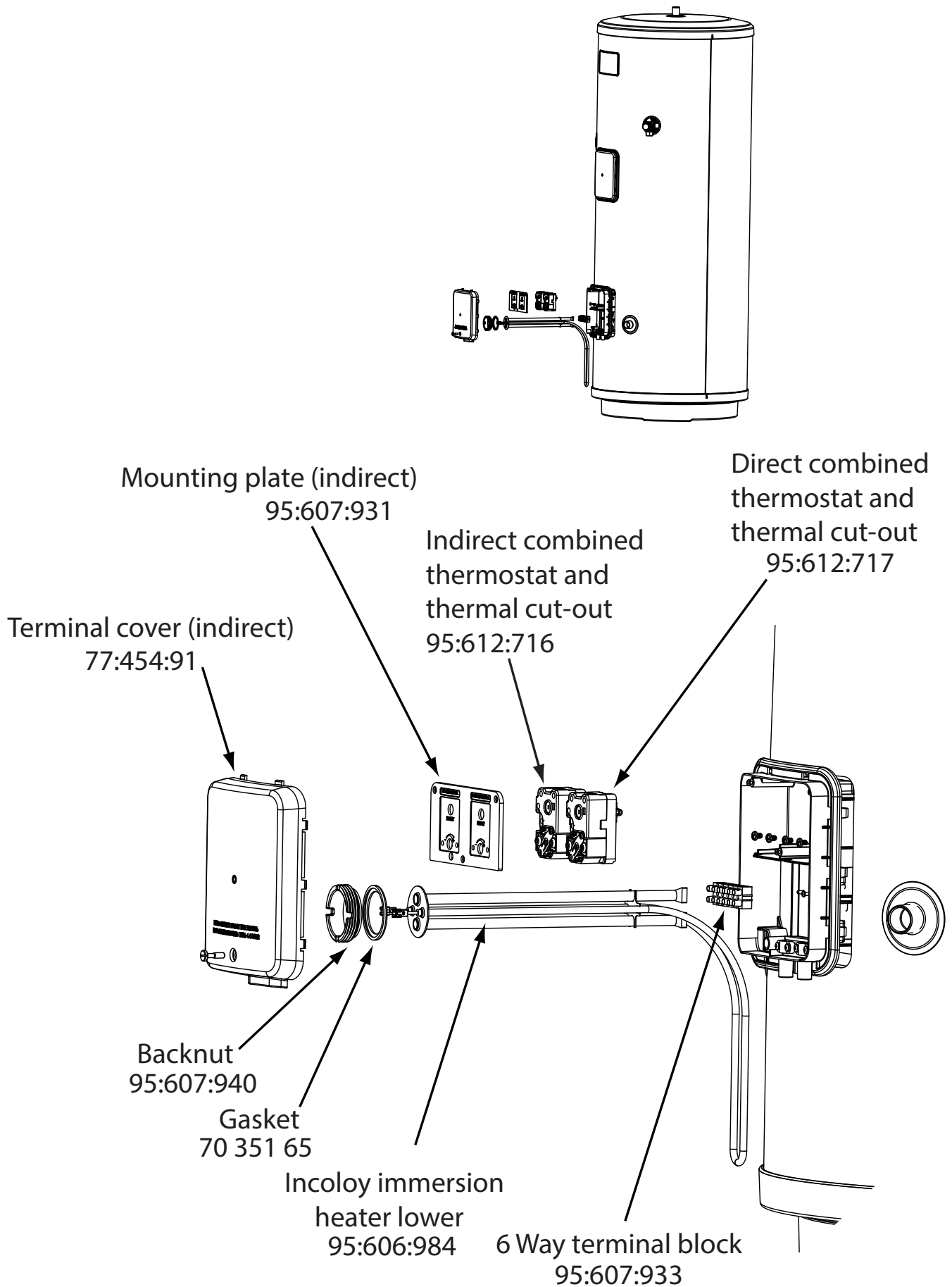

Figure 18: Indirect exploded view

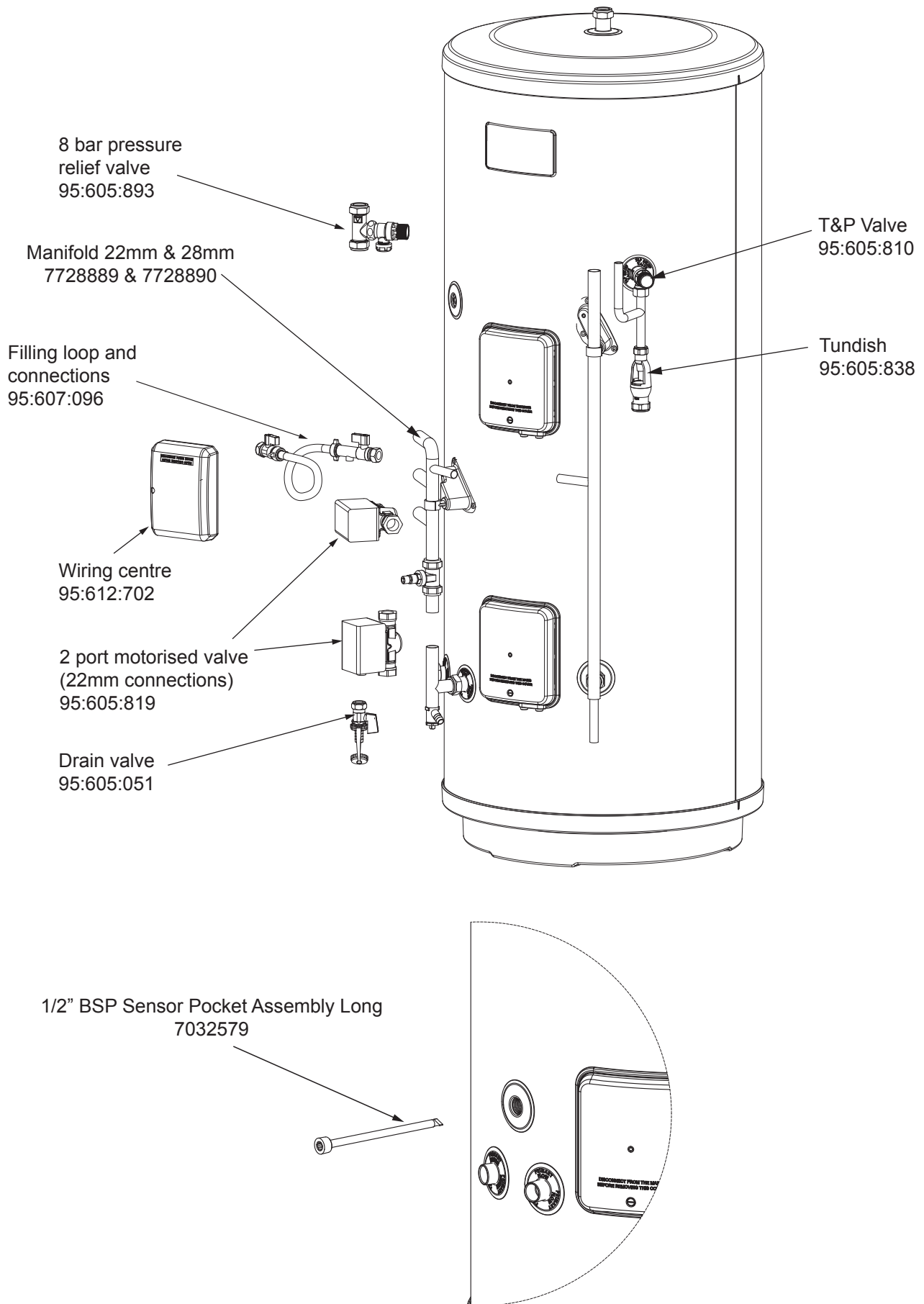

Figure 19: Indirect exploded view

WEEE Declaration

Disposal of Waste Equipment by Users in Private Household in the European Union.



This symbol on the product indicates that this product must not be disposed of with your other household waste. Instead, it is your responsibility to dispose of your waste equipment by handing it over to a designated collection point for the recycling of waste electrical equipment. The separate collection and recycling of your waste equipment at the time of disposal will help to conserve natural resources and ensure that it is recycled in a manner that protects human health and the environment. For more information about where you can drop off your waste equipment for recycling, please contact your local city office, your household waste disposal service or the company where this product was purchased.

Spares Stockists

Electric Water Heating Co.
2 Horsecroft Place
Pinnacles
Harlow
Essex CM19 5BT
Tel: 0845 0553811
E-Mail: sales@ewh.co.uk

SPD

Special Product Division
Units 9 & 10
Hexagon Business Centre
Springfield Road
Hayes
Middlesex UB4 0TY
Tel: 020 8606 3567

Parts Center

Tel: 0344 292 7057
www.partscenter.co.uk

Newey & Eyre

Unit 3-5 Wassage Way
Hampton Lovett Ind. Estate
Droitwich, Worcestershire
WR9 0NX
Tel: 01905 791500
Fax: 01905 791501

UK Spares Ltd

Unit 1155
Aztec West
Almondsbury
Bristol BS32 4TF
Tel: 01454 620500

Alternatively contact your local supplying merchant, wholesale branch or use our online stockist finder:-

<https://www.baxi.co.uk/trade/boilers-parts-and-accessories/parts/find-a-stockist>

Baxi Customer Support



0344 871 1545

Opening hours

Monday - Friday, 8.00am-6.00pm

Weekends and Bank Holidays, 8.30am-2.00pm

Please note calls may be recorded for training and monitoring purposes



baxi.co.uk

Register now to activate your warranty:
www.baxi.co.uk/registration

For the warranty to be maintained, please make sure...

- 1** Benchmark checklist is completed
- 2** Warranty is registered within 30 days
- 3** The cylinder has an annual service

For full terms and conditions, visit www.baxi.co.uk/terms. Failure to adhere to terms and conditions will void your manufacturer's warranty.



Baxi
Brooks House,
Coventry Road,
Warwick, CV34 4LL

CE
0085



Please ensure the cylinder is installed in accordance with these installation instructions and that you adhere to the Building Regulations.

e&oe

All descriptions and illustrations provided in this document have been carefully prepared but we reserve the right to make changes and improvements in our products which may affect the accuracy of the information contained in this leaflet. All goods are sold subject to our standard Conditions of Sale which are available on request.

BAXI