

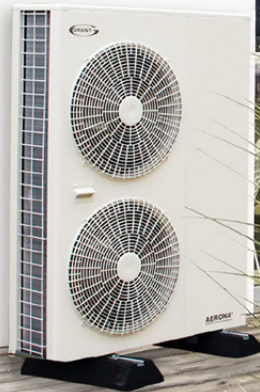

AERONA³ R32 HEAT PUMP RANGE

Inverter driven air source heat pumps
with outputs from
6kW to 17kW



Model shown HPID13R32



At Grant we have been designing and manufacturing reliable and easy to install heating products for four decades. From award winning oil-fired condensing boilers to the latest renewable technologies, our heating systems have a reputation for quality that is second to none.

We combine precision engineering, innovation, performance and value for money to produce sustainable heating solutions that are trusted by both installers and householders.

Quality Design

There is never a compromise on quality. We design all of our products so that you can be sure that the durability and efficiency are sector leading. We continually develop new technologies and use only the best materials to ensure our products exceed all performance and environmental standards.

Our belief in simple solutions ensures that, while our technology is sophisticated, our products are low maintenance and easy to install. For a high quality, reliable and sustainable heating system, trust in Grant.

Heating Responsibly

Grant manufacture heating systems that respond to the challenges of rising fuel costs whilst protecting our environment. Environmental responsibility is central to all we do and we continue to develop and innovate to produce even more efficient products that make best use of our natural resources.

We are passionate about developing sustainable, high-performance and affordable alternatives for heating homes into the future.

Our Guarantee

The Grant label is a guarantee of reliability, quality and value. We put our customers first and our independence ensures that we can monitor our standards and processes to deliver the very best quality and service.

That's why, when you order your system from a Grant stockist, you can be sure of a tailored service and excellent after sales support.

Heat Pump Technology



What are Air Source Heat Pumps?

Air source heat pumps use basic thermodynamic principles to convert thermal energy contained within the air we breathe into heat energy that can be used to provide heating and hot water. This 'ambient heat' is replenished by the sun making our heat pumps both effective and environmentally friendly.

How Heat Pumps Work

There are two basic types of air source heat pump - 'air to air' and 'air to water'. Grant AERONA³ heat pumps use an air to water system which utilises heat energy captured from the air in 'wet' heating system radiators or underfloor heating. The process uses the same vapour/compression cycle that extracts heat in a domestic fridge. A refrigerant with a low boiling point is exposed to external air temperatures in an evaporator. The liquid boils off to a gas and absorbs the thermal energy of the air. This gas is then compressed increasing the heat energy contained within the refrigerant, before passing through a heat exchanger where it condenses back to a liquid form, whilst transferring the heat to the water of the heating system. The liquid refrigerant is then re-circulated through the evaporator and the cycle is repeated.

Fit for the Future

With the recent fluctuations in price and supply of fossil fuels, air source heat pumps offer both an environmentally and economically sustainable alternative. Home heating in the UK accounts for approximately 30% of CO₂ emissions. The heat source used by Grant AERONA³ heat pumps is entirely renewable which helps reduce the amount of harmful greenhouse gases being released into the atmosphere and, in so doing, lowers the carbon footprint of the household.

Lower Heating Costs

Compared with other domestic heating methods, the Grant AERONA³ can benefit homeowners by creating annual savings on fuel bills. The units can deliver over four times the amount of energy for every 1kW of electricity used depending on the flow temperature and the climate conditions prevailing at the time. Homes utilising this type of heat generator will obviously have a lower dependency on fossil fuels, making them less susceptible to rising fuel costs.

Grant Aeronas³ R32 Range

Introducing the Aeronas³ R32

The Aeronas³ R32 inverter driven air source heat pumps are Grant's greenest and most efficient heat pumps yet.

Incorporating R32 refrigerant which has a significantly lower Global Warming Potential compared to traditional refrigerants, the Aeronas³ R32 range models are cleaner and more eco-friendly while also being incredibly effective. With excellent SCOPs, all of the Aeronas³ heat pumps achieve high performances allowing homeowners to lower their dependency on fossil fuels while also reducing their annual fuel bills.



Up to 7 year guarantee*



HPID13R2 & HPID17R32



* Subject to full Terms & Conditions and status

Standing out from the crowd

Designed with the installer in mind

Grant's Aerona³ R32 air source heat pumps incorporate a number of features, as standard, which are all designed to make the installation quicker and easier for engineers.

From its integrated HE pump through to the simplified electrics, the Aerona³ has been designed to save installers time when on-site fitting the heat pump, reducing the installation time for engineers and efficiently restoring a property's heating for homeowners.



Straightforward to install

The Aerona³ is uncomplicated to install because it incorporates a common S-plan which minimises the number of alterations the installing engineer needs to make to the existing pipework. The simplified electrics, consisting of a 3-core cable for the wiring centre and a 2-core flex for the controller, also make for a straightforward installation. Furthermore, the Aerona³ incorporates a built-in HE pump which saves time and space. By not having to add an external pump, the engineer saves time on the pipework and the electrician saves time because there is no need to wire in an external pump.

User-friendly for homeowners

The Aerona³ heat pumps are compatible with a property's existing control system for the majority of installations. This means that homeowners can continue to use their familiar controller if they prefer, thus reducing the time spent installing and handing over a new control system. This can offer greater peace of mind for the end-user who is able to manage their new Aerona³ heat pump with their original controller.

Simple to service and maintain

The Aerona³ has front access with all of its major components located at the front of the heat pump unit which makes the maintenance of the product simple and easy. As with all of Grant's products, the Aerona³ heat pump has

been developed to make life easier for both the installer and the service engineer. With its components made accessible, all of the Aerona³ models are straightforward to clean and maintain.

Interface Relay Box

All of Grant's Aerona³ air source heat pumps are supplied with an Interface Relay Box which is designed to easily and conveniently provide the volt free switching required by the heat pumps. It uses the heating and hot water switched live outputs from the heating system wiring centre.

The Relay box can be installed next to the wiring centre or, alternatively, it can be located nearer to the Aerona³ heat pump. Please note, it cannot be installed externally.

Anti corrosive coating

Sea air can be damaging to air source heat pumps fitted in coastal areas. For this reason, Grant offer Blygold corrosion protection on the Aerona³ range to help preserve and maintain heat pumps installed in the vicinity of the sea.

Included as standard

Each Aerona³ R32 unit is supplied with all of the following as standard:

- Factory fitted HE pump
- Flexi hoses
- Condensate drain elbow
- Isolating valves
- Remote controller and 8m cable

Technical Specification

		HPID6R32	HPID10R32	HPID13R32	HPID17R32
ErP Rating*		A+++	A+++	A+++	A+++
Height (mm)		675	882	1418	1418
Width (mm)		898	874	1024	1024
Depth (mm)		379.4	405	403	403
Weight (kg)	Empty	51	70	99	118
	Full	52.8	71.8	101	120
Heating capacity (kW) (BS EN 14511 - air 7°C/ Water 35°C)		6.92	11.1	13.6	18.0
Heating capacity (kW) (BS EN 14511 - air 7°C/ Water 55°C)		6.24	10.5	11.4	15.3
COP (BS EN 14511 - air 7°C/ Water 35°C)		4.91	5.28	5.25	4.79
COP (BS EN 14511 - air 7°C/ Water 55°C)		3.04	3.12	3.23	3.15
SCOP average climate conditions (Water 35°)		4.61	5.19	5.4	4.47
SCOP average climate conditions (Water 55°)		3.30	3.46	3.72	3.54
Refrigerant (R32) (kg)		0.80	1.55	2.20	2.80
Power supply		~230V 1ph 50Hz			
Water connections (BSPF)		3/4"	1"	1 1/4"	1 1/4"
Min/ Max operating temperatures Air (°C)		-20/43	-20/43	-20/43	-20/43
Sound power level dB(A) (BS EN ISO 3743-1:2010)		65.2	64	60.8	61.6
Sound pressure level at 1m - external (dB(A)) (Q=1)		54.2	53	49.8	50.6
Max running current (A)		11.2	17.5	23.0	25.3
MCB	Rating (A)	16	20	32	32
	Type	C	C	C	C

* Low temperature: 35°C flow (heating). From September 2019

HPID6R32

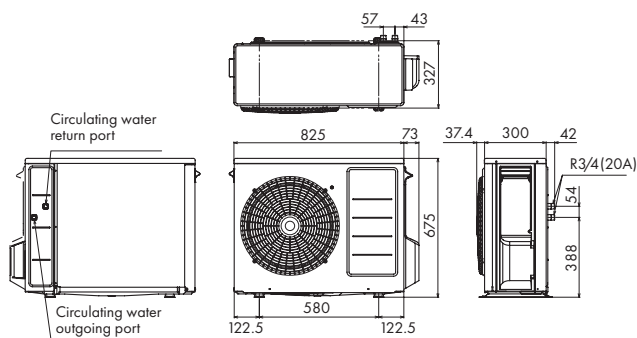

HPID10R32

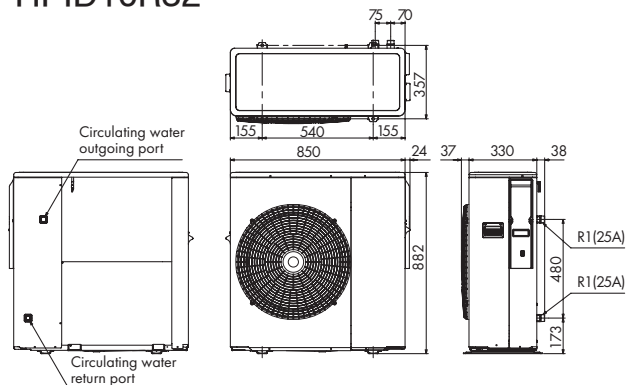

HPID13R32 & HPID17R32

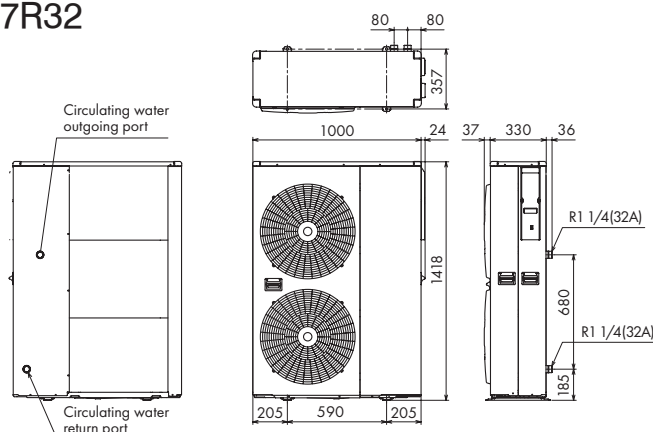

Performance & Efficiency

Performance Information						
Model			HPID6R32	HPID10R32	HPID13R32	HPID17R32
Heating capacity at	0°C air	35°C flow	6.2kW	10.1kW	12.5kW	16.5kW
	0°C air	55°C flow	5kW	9.7kW	10.5kW	15.3kW
Heating capacity at	-3°C air	35°C flow	5.9kW	9.8kW	12.2kW	15.8kW
	-3°C air	55°C flow	4.7kW	9.4kW	10.2kW	14.6kW

Seasonal Coefficient of Performance (SCOP)

The SCOP is the overall performance of the heat pump when used in a designated heating season (warm, average or cold), calculated as the reference annual heating demand divided by the annual energy consumed. For the UK, it is predominantly split into two heating seasons: warm for the south (diagonal line from north Wales to the Kent coast) and average for the rest of the UK mainland, including the Scottish islands of Orkney and Shetland.

Testing is carried out to European and British Standard BS EN 14825 establishing the seasonal space heating energy efficiency and SCOP at various ambient temperatures and system flow temperatures. For example, the Grant Aeronas³ HPID6R32 model produces an average SCOP of over 4 when tested at low temperature and average climate conditions. This means, for every kilowatt (kW) of energy used to run the

Aeronas³, over 4kW of energy is being given to the heating system in return.

It is important to note that as the outside air gets colder, the output and therefore the SCOP of an air source heat pump falls slightly, due to the reduced amount of heat energy available from the air. Conversely, when outside air temperature gets warmer, the output and COP will increase. By using SCOP as opposed to COP, these peaks and troughs are evened out into a realistic annual coefficient.

The overriding factor of the Aeronas³ heat pump is that the output will modulate down or up depending on the climate conditions and the demand on the heating system, giving you peace of mind that you are as energy efficient as you can possibly be on every day of the year.

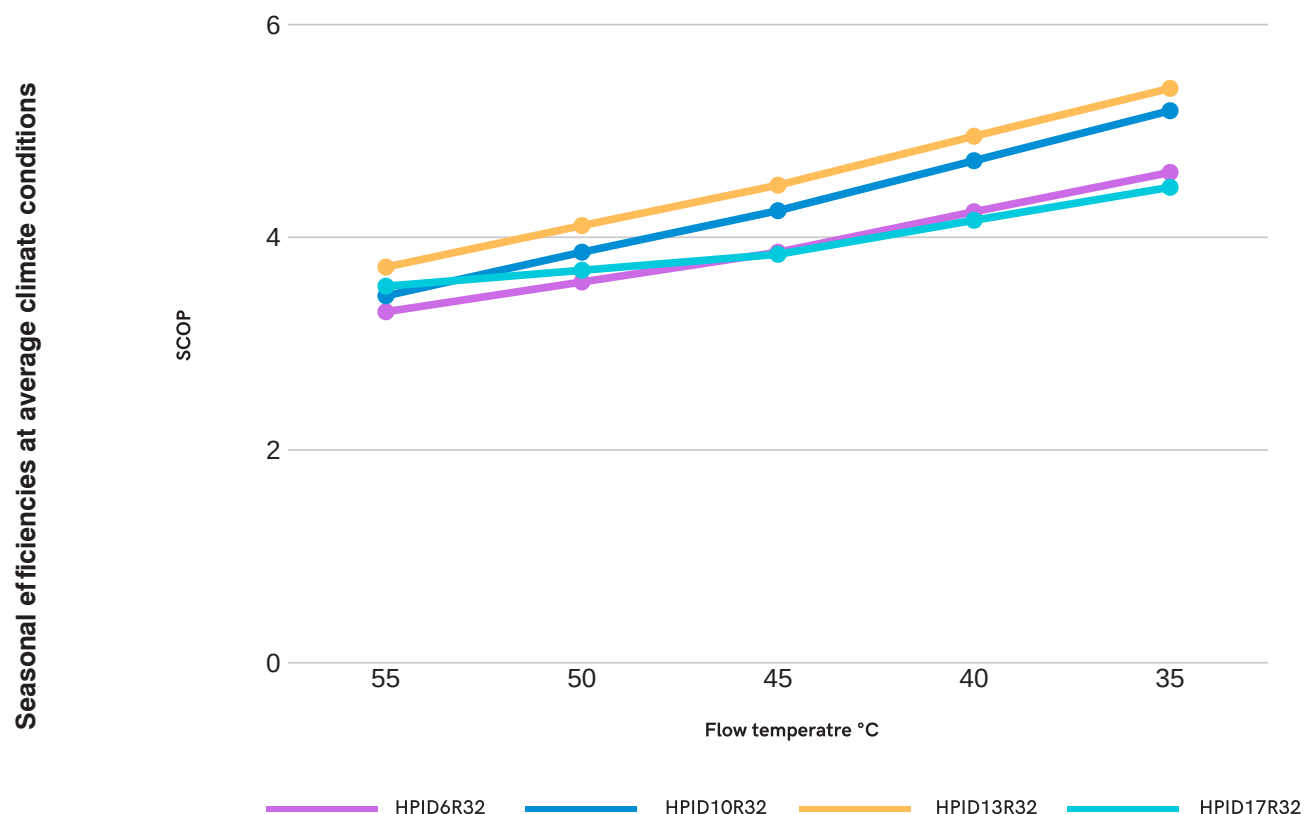

Aerona³ ASHP Packs

To make life a little easier we now offer heat pump packs which consist of the Aerona³ air source heat pumps and their key accessories.

Four packs are available, one for each of the Aerona³ inverter driven air source heat pumps. Alongside the heat pump model, each pack also contains a flexi foot kit, Mag One filter, domestic hot water boost kit, sealed system kit, through wall insulation kit, Fernox inhibitor and AC isolator.

These packs not only make ordering easier but also deliver cost savings as well. Installers can source all of these items using one code, making product orders considerably simpler. With these packs, a heat pump and its six essential accessories are all included within one code. Furthermore, ordering these packs is cost effective. Compared to buying the products individually, each of these heat pump packs can help installers make a saving of over £140*.

Code	Pack Contents
HPID6R32PACK	6kW ASHP, flexi foot kit, Mag One filter, domestic hot water boost kit, 18lt sealed system kit, through wall insulation kit, AC isolator, 25lt Fernox HP-5C inhibitor
HPID10R32PACK	10kW ASHP, flexi foot kit, Mag One filter, domestic hot water boost kit, 18lt sealed system kit, through wall insulation kit, AC isolator, 25lt Fernox HP-5C inhibitor
HPID13R32PACK	13kW ASHP, flexi foot kit, Mag One filter, domestic hot water boost kit, 18lt sealed system kit, through wall insulation kit, AC isolator, 25lt Fernox HP-5C inhibitor
HPID17R32PACK	17kW ASHP, flexi foot kit, Mag One filter, domestic hot water boost kit, 18lt sealed system kit, through wall insulation kit, AC isolator, 25lt Fernox HP-5C inhibitor



* Based on individual product RRP as of 1st March 2019.

Flexi hoses, isolation valves, ATC controller and factory fitted HE circulating pump.



Unlock all the benefits of MCS certification on your Grant renewable install.

What is G-CERT?

G-CERT is a scheme from Grant UK, through which Grant can certify renewable installations for MCS accreditation on behalf of the installer. In brief, under the G-CERT Scheme, engineers can install RHI eligible systems without needing to be MCS accredited themselves.

What will Grant UK do?

Act as the MCS accredited organisation.

Assist with heat loss calculation, heat pump/ biomass/ solar system selection, DNO application (where applicable) and risk assessments.

Commission each system and sign off the installation on behalf of the installer.

Supply the end-user Handover Folder.

Notify Building Control of the installation.

Complete all necessary notifications including: registering each install on the MCS Database, registering each install for the Workmanship Warranty Insurance and registering the products for their Grant warranty.

Benefits

Customer will have access to RHI payments and extended product guarantees.

Reduced time and cost associated with MCS accreditation.

Grant UK will produce full customer Handover Folder.

1 visit by Grant UK to commission and certify the system for MCS and assist the installer with the system handover.

Installer does not need to operate MCS Quality System.

For more information visit:

www.grantuk.com/trade/g-cert-scheme

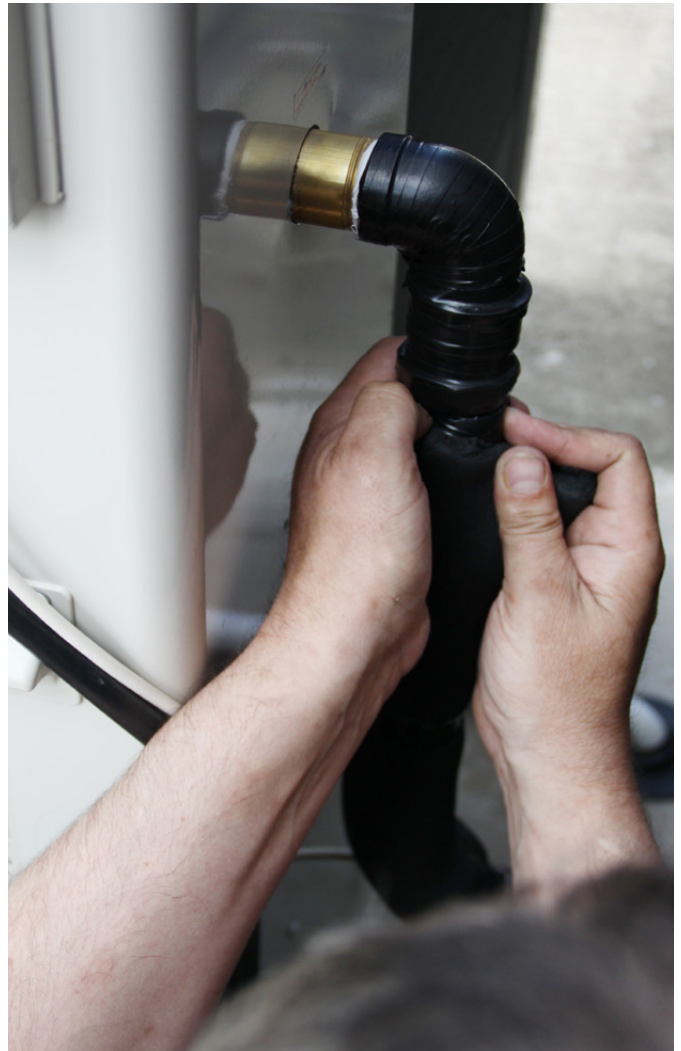

Aerona³ Accessories

To accompany the Aerona³, Grant UK also supply a range of heat pump accessories compatible with all of the models. These accessories are available to purchase individually or as part of a heat pump pack (as shown on page 8).

Sealed system kits

Sealed system kits are available to suit all Aerona³ heat pump models. The kits come in 3 sizes: 12ltr, 18ltr and 50ltr. **Part code:** HPAWSSK112/ HPAWSSK18/ HPAWSSK50

Flexi-foot kit with fixings

Available in a pack comprising of 2x 600mm feet for mounting the Aerona³, these are both anti-vibration and raise the heat pump off the ground. **Part code:** HPIDFOOT/KIT2

Through wall insulation kit

This is a heavy duty 22-28mm flexi hose specifically designed for the Aerona³. **Part code:** HPIDINSU/KIT

Domestic Hot Water (DHW) Boost Kits

Our DHW boost kit automatically switches on the cylinders immersion element when the heat pump has raised the cylinder contents to about 45°C, taking the water up to the desired water temperature, set by the immersion thermostat. It has an additional feature of automatic bacteria protection. An integrated timer can be programmed to bring on the immersion either daily or weekly for a short period of time, allowing sanitisation of the cylinder contents. This sanitisation regime is a requirement of SAP and should be fitted with every heat pump/cylinder installation. **Part code:** HPDHWBK2

Hot Water Priority Relay

This relay gives hot water priority within the central heating system. When the hot water boost is turned on as a result of needing hot water served within the home, the Grant Water Priority Relay will close the valve to the heating system. This allows the cylinder to fill with hot water without taking hot water from the heating system, satisfying the demands for both hot water and heating simultaneously. **Part code:** HPWPR1

Volumisers & Buffers

It is a requirement for a system volumiser to be fitted with every Grant ASHP or hybrid installation. Grant's range of buffers and volumisers allow for different configurations of the flow and return to and from the heat source, helping to maintain a constant flow rate and maximise system efficiency.



HPIDBUFFER50

50 litre un-insulated volumiser (1 flow / 1 return connection)



HPIDVOL30

30 litre insulated volumiser (1 flow / 1 return connection)



HPIDBUFF50X

50 litre insulated buffer (2 flow/ 2 return connections) with 3kW immersion heater



ErP Heating & Hot Water Packages



Improving your ErP rating

Under the ErP Directive, when installing additional heating technologies alongside your heat pump a 'package label' is needed. This details the overall system efficiency rating. It does not apply if you are only installing a heat pump with a hot water cylinder, as this combination is not seen as a 'package' under the Directive.

By combining additional technologies such as solar and controls, you can actually improve the overall package efficiency. Each product would effectively add an efficiency percentage to the heat pump's seasonal space heating ErP rating.

For example, a 10kW AERONA³ (featuring integral weather compensation and controls) with a Grant DuoWave 300 litre heat pump cylinder and a two collector on-roof Sahara solar thermal kit, can achieve an ErP package rating of A+++.

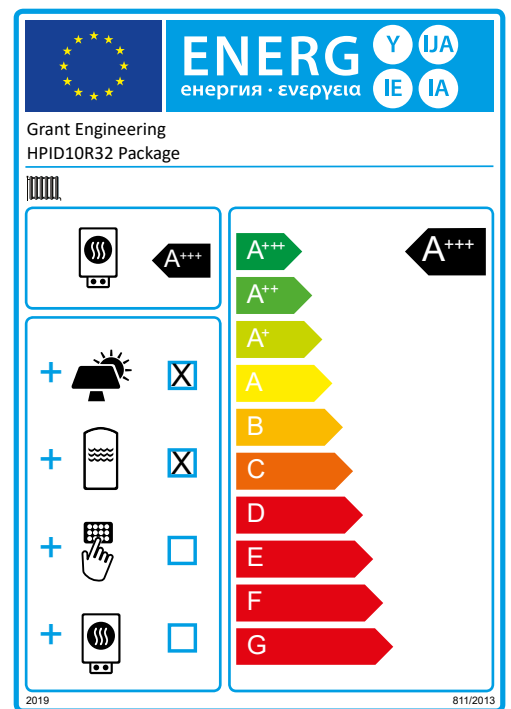

Example package label



Grant Heat Pump cylinder range

Duplex stainless steel unvented indirect, mains pressure cylinders with single coil versions for air source heat pumps and a twin coil option for combining an additional heat source.

Heat Pump cylinders

The Grant range of stainless steel heat pump cylinders is specifically matched to Aerona³ air to water heat pump range, which incorporate a larger primary coil for quicker heat transference. The cylinders are available in seven indirect single coil versions ranging from 125-400 litres and five indirect twin coil versions ranging from 170-400 litres. Grant Heat Pump cylinders feature compression fittings which are conveniently located to make installation quicker and easier.

ErP A-Rated MonoWave

The A-rated Grant MonoWave 200 litre single coil cylinder offers higher levels of efficiency compared with standard MonoWave models, due to its construction and increased insulation.

A

GRANT
MONOWAVE
HEAT PUMP
CYLINDER

Grant MonoWave connections

- A Hot out
- B T+P valve
- C Secondary return
- D Heat pump flow
- E Heat pump return
- F Thermostat pocket
- G Immersion heater
- H Cold In
- I Immersion heater (300 & 400ltr models only)

Grant MonoWave with buffer connections

- A Hot out
- B T+P valve
- C Secondary return
- D Primary flow
- E Primary return
- F Thermostat pocket
- G Immersion heater
- H Cold In
- I Flow & return from ASHP
- J Flow & return to cylinder coil & heating circuits

Grant pre-plumbed MonoWave with buffer connections

- A Flow to heating zone 1
- B Flow to heating zone 2
- C Flow from ASHP
- D Return from ASHP
- E Return from heating circuits
- F Flow to DHW

Grant DuoWave connections

- A Hot out
- B T+P valve
- C Secondary return
- D Heat pump flow
- E Heat pump return
- F Thermostat pocket
- G Immersion heater
- H Cold In
- I Immersion heater (300 & 400ltr models only)

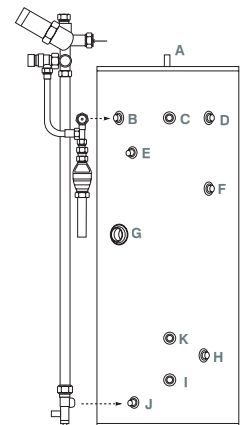
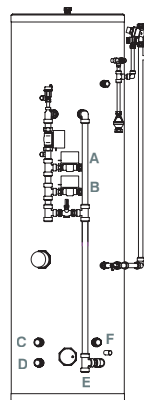
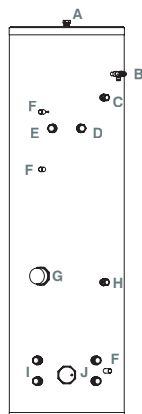
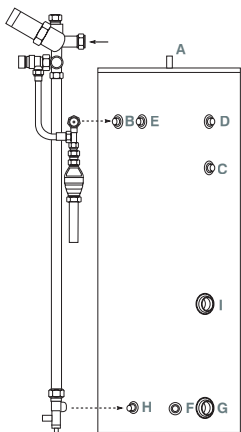

Grant MonoWave Heat Pump cylinders unvented indirect single coil duplex stainless steel

Model	Capacity (ltrs)	ErP Rating	Pressure regulator (bar)	Immersion fitted (kW)	Expansion vessel (ltrs)	Coil rating primary (kW)	Standing heat loss (kW/24hrs)	Height (mm) ^	Diameter (mm)	Weight empty (kg)	Weight full (kg)
HPMONO/IND125	125	C	3	3	12	24.0	1.4	835	580	30	155
HPMONO/IND150	150	C	3	3	12	27.8	1.44	940	580	32	182
HPMONO/IND170	170	C	3	3	19	27.8	1.48	1085	580	45	215
HPMONOA/IND200	200	A	3	3	19	47.0	1.03	1930	580	70	270
HPMONO/IND200	200	B	3	3	19	47.0	1.54	1215	580	49	249
HPMONO/IND250	250	C	3	3	24	47.0	1.83	1410	580	59	309
HPMONO/IND300	300	C	3	3*	24	56.6	2.08	1700	580	68	368
HPMONO/IND400	400	C	3	3*	35	56.6	2.38	2110	580	76	476

Grant MonoWave High Performance Cylinders | Unvented | Indirect | Single Coil | Integral 50lt Buffer

Model	Capacity (ltrs)	ErP Rating	Pressure regulator (bar)	Immersion fitted (kW)	Expansion vessel (ltrs)	Coil rating primary (kW)	Standing heat loss (kW/24hrs)	Height (mm) ^	Diameter (mm)	Weight empty (kg)	Weight full (kg)
HPFR200C/BS	200	C	3	3**	19	46	1.88	1760	580	60	302***
HPFR250C/BS	250	C	3	3**	24	46	2.02	1930	580	67	357***
HPFR300C/BS	300	C	3	3**	24	64	2.21	2149	580	74	414***

Grant MonoWave High Performance Cylinders | Unvented | Indirect | Single Coil | Integral 50lt buffer | Pre-Plumbed

Model	Capacity (ltrs)	ErP Rating	Pressure regulator (bar)	Immersion fitted (kW)	Expansion vessel (ltrs)	Coil rating primary (kW)	Standing heat loss (kW/24hrs)	Height (mm) ^	Diameter (mm)	Weight empty (kg)	Weight full (kg)
HPFR200PPC/BS	200	C	3	3**	19	46	1.88	1760	580	60	302***
HPFR250PPC/BS	250	C	3	3**	24	46	2.02	1930	580	67	357***
HPFR300PPC/BS	300	C	3	3**	24	64	2.21	2149	580	74	414***

Grant DuoWave Heat Pump cylinders unvented indirect solar twin coil duplex stainless steel

Model	Capacity (ltrs)	ErP Rating	Pressure regulator (bar)	Immersion fitted (kW)	Expansion vessel (ltrs)	Coil rating primary (kW)	Solar (kW)	Standing heat loss (kW/24hrs)	Height (mm) ^	Diameter (mm)	Weight empty (kg)	Weight full (kg)
HPDUO/IND170	170	C	3	3	19	32	8.5	1.48	1080	580	57	227
HPDUO/IND200	200	B	3	3	19	47	10	1.54	1195	580	61	261
HPDUO/IND250	250	C	3	3	24	47	16	1.80	1480	580	71	321
HPDUO/IND300	300	C	3	3	24	55.6	16	2.09	1680	580	80	380
HPDUO/IND400	400	C	3	3	35	55.6	23	2.38	2105	580	100	500

Grant Cylinder Accessories

Model	Description	Height (mm)	Diameter (mm)	Weight empty (kg)	Weight full (kg)	Actual capacity (ltrs)	Connections (BSP)
HPIDBUFF50X	Grant 50 litre insulated buffer (2 x flow / 2x return connections) c/w 3kW immersion heater	410	475	10	58	48	1"
HPIDVOL30	Grant 30 litre volumiser (1x flow/ 1x return connection)	360	475	8	41.5	33.5	1"

* 2 x 3kW immersion heaters

^ Includes HW outlet connection



Multiple Package Solutions. All From Grant.

A heating system's overall efficiency can be significantly improved by combining multiple technologies. By installing an air source heat pump alongside a high performance cylinder and effective heat emitters, a home's heating system can be taken into a new class of efficiency. And, what's more, you can get all of these products from Grant.

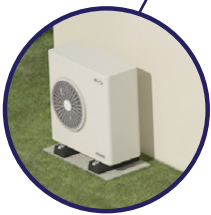
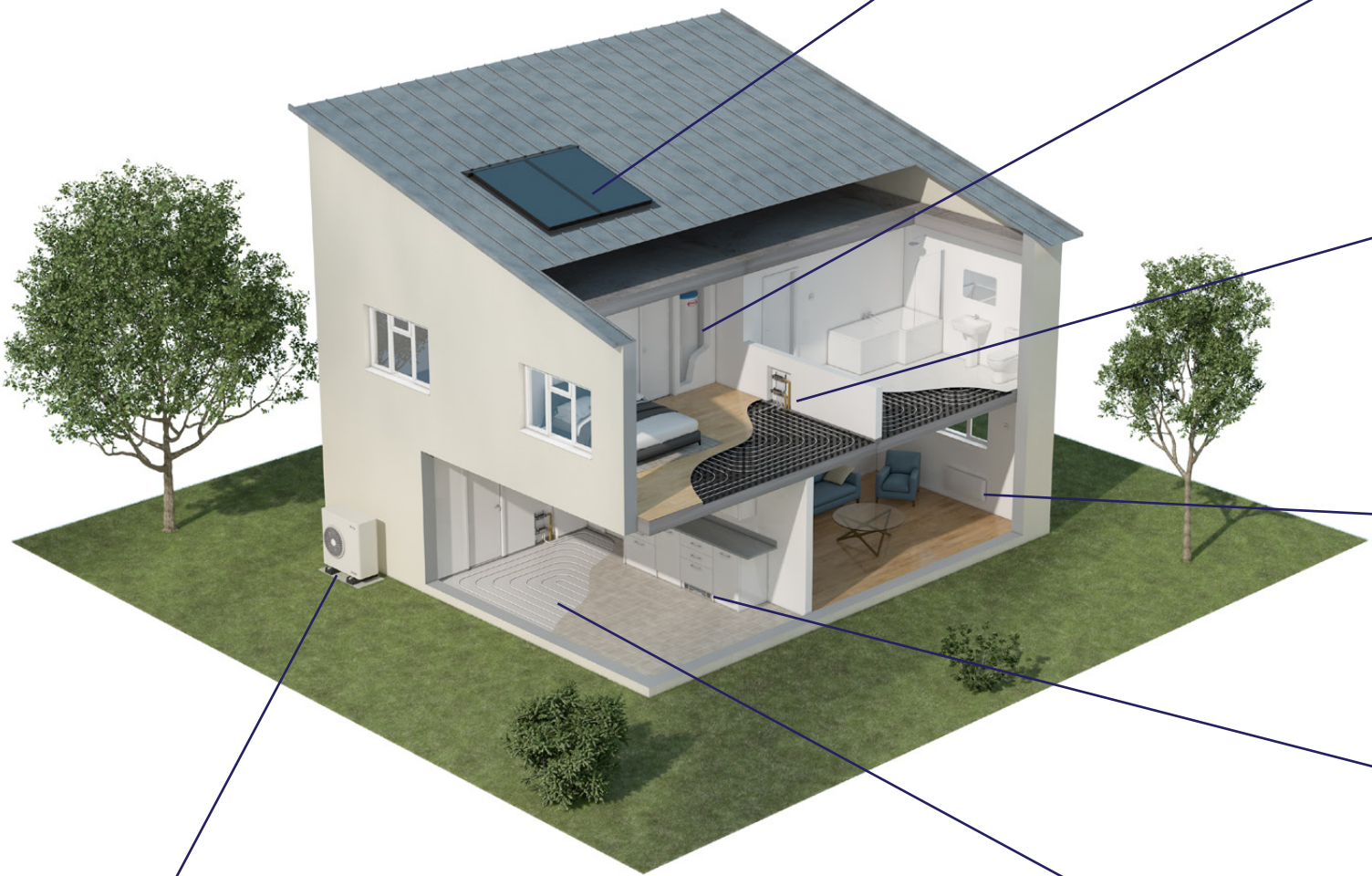

Aeronas³ air source heat pumps

- Exceptional SCOP's sustainable at low temperatures
- MCS approved
- Factory fitted weather compensation control

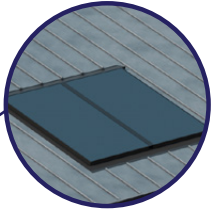

Sahara solar thermal

- On roof, in-roof & flat roof mounting options
- Solar Keymark approved
- Simple ordering process



Wave high performance cylinders

- Pre-plumbed, single & twin coil options
- Fast recovery stainless steel coils
- Sizes between 125 - 400 litres

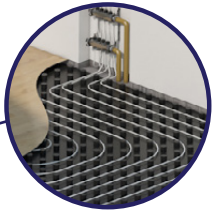

Uflex MINI underfloor heating

- Very low profile (15mm finished floor height)
- Suitable for ground & first floor installation
- Quick installation & drying time



Solo fan convectors

- Flexible zone & temperature control
- Low energy consumption
- Small & slim in size



Solo Hideaway fan convectors

- Under cabinet plinth heater
- Low energy consumption
- Adjustable temperature control



Uflex underfloor heating

- Quick reaction time
- Ideal for new builds or extensions
- Highly efficient

NEW



Afinia
aluminium radiators by Grant

find out more
www.grantuk.com

Guarantees

Grant Engineering (UK) Limited guarantees the manufacture of the heat pump including all electrical and mechanical components for a period of **twelve months from the date of installation**, unless the installation was more than six months from the date of purchase, in which case the guarantee period will commence six months from the date of purchase, provided that the heat pump has been installed in full accordance with the installation and servicing manual issued. This will be extended to a total period of **two years** if the heat pump is registered with Grant Engineering (UK) Limited **within thirty days of installation** and serviced at twelve monthly intervals. To register your air source heat pump visit: www.grantuk.com.

Extended guarantees are available when installed by G1 accredited installers. To find a local G1 installer please visit <https://www.grantuk.com/support/find-an-engineer/>

Aftersales Service

For peace of mind, all Grant Aeronas³ heat pumps are backed by Grant's comprehensive service operation and in the unlikely event of a problem occurring, your installer should telephone our Customer Service Department on: **+44 (0)1380 736920**

Heat Pump Cylinders

Grant stainless steel heat pump cylinders are specifically matched to the Aeronas³ range and incorporate a larger primary coil for quicker heat transference.

The cylinders are available in seven indirect single coil versions, ranging from 125-400 litres and five indirect twin coil versions ranging from 170-400 litres. They feature compression fittings which are conveniently located to make installation quicker and easier. For more information and sizes, visit our website: www.grantuk.com

Installation and Maintenance

The installation of a Grant Aeronas³ heat pump should be carried out by a Grant G-One Accredited Heat Pump Installer. More information on this scheme is available from the Grant UK website. Servicing should be carried out annually by a qualified heating engineer. During servicing it is important for the engineer to ensure that the evaporator matrix is clear of debris as any build up could significantly affect the performance of the heat pump.



Grant Engineering (UK) Ltd

Hopton House, Hopton Industrial Estate,
Devizes, Wiltshire, SN10 2EU

t: +44 (0)1380 736920 f: +44 (0)1380 736991

e: sales@grantuk.com w: www.grantuk.com



Magnetic Central Heating Filter

The MagOne (Part code: VM01) provides innovative protection for your Grant Aeronas³ Air Source Heat Pumps. Using a simple to install, triple action filtration design, the MagOne filters magnetite and non-ferrous debris from central heating systems with a 12000 gauss neodymium magnet.

Approvals

Grant Aeronas³ heat pumps are manufactured using CE approved components. To ensure performance standards, the units have been tested and approved in a UK test house to BS EN 14511 and EN14825.

This leaflet is accurate at the time of printing but as Grant UK has a policy of continual improvement it may be superseded. We reserve the right to amend specifications without prior notice. The statutory rights of the consumer are not affected.

All products manufactured under I.S. EN ISO 9001. Grant UK additionally holds ISO 14001 accreditation.

TMTHE GRANT 'EZ-FIT FLUE' SYSTEM is a trade mark of Grant Engineering Limited.

®Grant Aeronas³, Grant Spira, Grant Vecta, Grant SpiraVac, Grant SpiraPod, Grant Vortex, Grant VortexBlue, Grant VortexAir, Grant Solar, Grant Aurora, Grant Sahara, Grant CombiSOL, Grant WinterSOL, Grant MonoWave, Grant DuoWave, Grant ThermaWave, Euroflame and Multi Pass are registered trade marks of Grant Engineering Limited. The contents of this leaflet are fully protected by copyright and nothing may be reproduced without permission from Grant UK.

