

Tesi Single Lever Basin Mixer, with Pop-Up Waste

ILLUSTRATED

A6592 Tesi single lever basin mixer with pop-up waste and 5lpm eco flow regulator

ILLUSTRATED PRODUCT DETAILS

Weights

A6592 1.71 KG

Materials

A6592 Chrome Plated Metal

Finishes

A6592  Chrome (AA)

Flow rates

A6592 5 Litres per minute @ 3 bar pressure

Designer

Artefakt Industriekultur

Standards

BS EN817

Special Notes

Suitable for balanced supplies. Inlets with flexible hoses and 15mm compression connections. Factory fitted 5 lpm flow regulator. Consideration should be given to safe hot water delivery and the use of an appropriate temperature reduction device such as A5900AA. Unregulated flow rate 4.7 litres per minute at 0.3 bar.

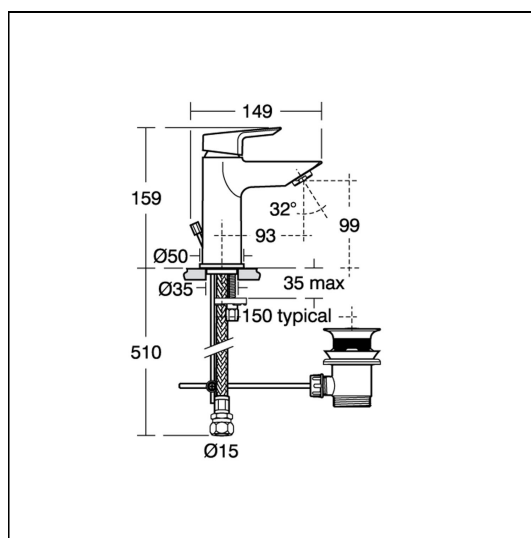

ACCREDITATIONS



FEATURES

