

New MAGNA1

Model C

Circulator pumps

50/60 Hz



be
think
innovate

GRUNDFOS 

1. Product data	3
Type key	4
Performance range, MAGNA1	5
Product range	7
A quick guide to pump selection	9
System applications	10
2. Construction	11
Motor and electronic controller	11
Pump connections	11
Surface treatment	11
Sectional drawings	12
3. Operation	13
Operating conditions	13
Electrical data	14
4. Installation	15
Mechanical installation	15
Electrical installation	15
5. Control and communication	18
Control modes	18
Overview of the control modes	19
Selecting control mode	20
Twin-head pump function	20
Operating panel	21
Communication	21
6. Performance curves	23
How to read the curve charts	23
Curve conditions	24
Markings and approvals	25
7. Performance curves and technical data	26
8. Accessories	108
Insulating kits for air-conditioning and cooling systems	108
Blanking flanges	108
ALPHA plug accessories	108
Grundfos GO	109
Pipe connection	110
9. Product numbers	115
MAGNA1 for the international market	115
Single-head pumps	115
Twin-head pumps	116
MAGNA1 for the German market	117
Single-head pumps	117
Twin-head pumps	118
10. Grundfos Product Center	119

1. Product data

Product description

The New MAGNA1 model C circulator pumps are designed for circulating liquids in the following systems:

- heating systems
 - main pump
 - mixing loops
 - domestic hot-water systems
 - heating surfaces
 - air-conditioning surfaces
- air-conditioning and cooling systems
- ground-source heat-pump systems
- solar-heating systems.

The pumps are designed for circulating liquids in heating systems with variable flow rates. The pumps are also suitable for domestic hot-water systems. We strongly recommend that you use stainless-steel pumps in domestic hot-water systems to avoid corrosion.

To ensure correct operation, it is important that the sizing range of the system falls within the duty range of the pump.

Duty range

Data	MAGNA1 (N) single-head pumps	MAGNA1 D twin-head pumps
Maximum flow rate, Q	71 m ³ /h	110 m ³ /h
Maximum head, H	18 metres	
Maximum system pressure	1.6 MPa (16 bar)	
Liquid temperature	-10 to 110 °C	



Fig. 1 Single-head MAGNA1 pumps

TM05 5863 4112 - TM06 9077 3617

Characteristic features

- Proportional-pressure control
- constant-pressure control
- constant-curve, constant-speed duty
- no external motor protection required
- insulating shells supplied with single-head pumps for heating systems
- wide temperature range due to thermal separation of the control box and pumped media.

Benefits

- Fault relay
- Digital input (start/stop)
- Wireless multipump function with time based alternation
- Simple installation
- LED indication of the control mode
- Low noise level
- No maintenance and long life
- The complete range is available for a maximum system pressure of 16 bar (PN 16).
- The new MAGNA1 is designed to communicate with Grundfos GO Remote, which allows you to:
 - Adjust the setpoint of the proportional pressure curve
 - Manage the fault-relay trigger setting in twin-head pumps
 - Read warning and alarm indications



Fig. 2 Connecting Grundfos GO Remote to MAGNA1

TM06 90813617

Type key

Code	Example	MAGNA1	D	80	-120	(F)	(N)	360
	Type range: MAGNA1							
D	Twin-head pump							
	Nominal diameter (DN) of inlet and outlet ports [mm]							
	Maximum head [dm]							
	Pipe connection: Threaded F Flange							
	Pump housing material: Cast iron N Stainless steel							
	Port-to-port length [mm]							

Performance range, MAGNA1

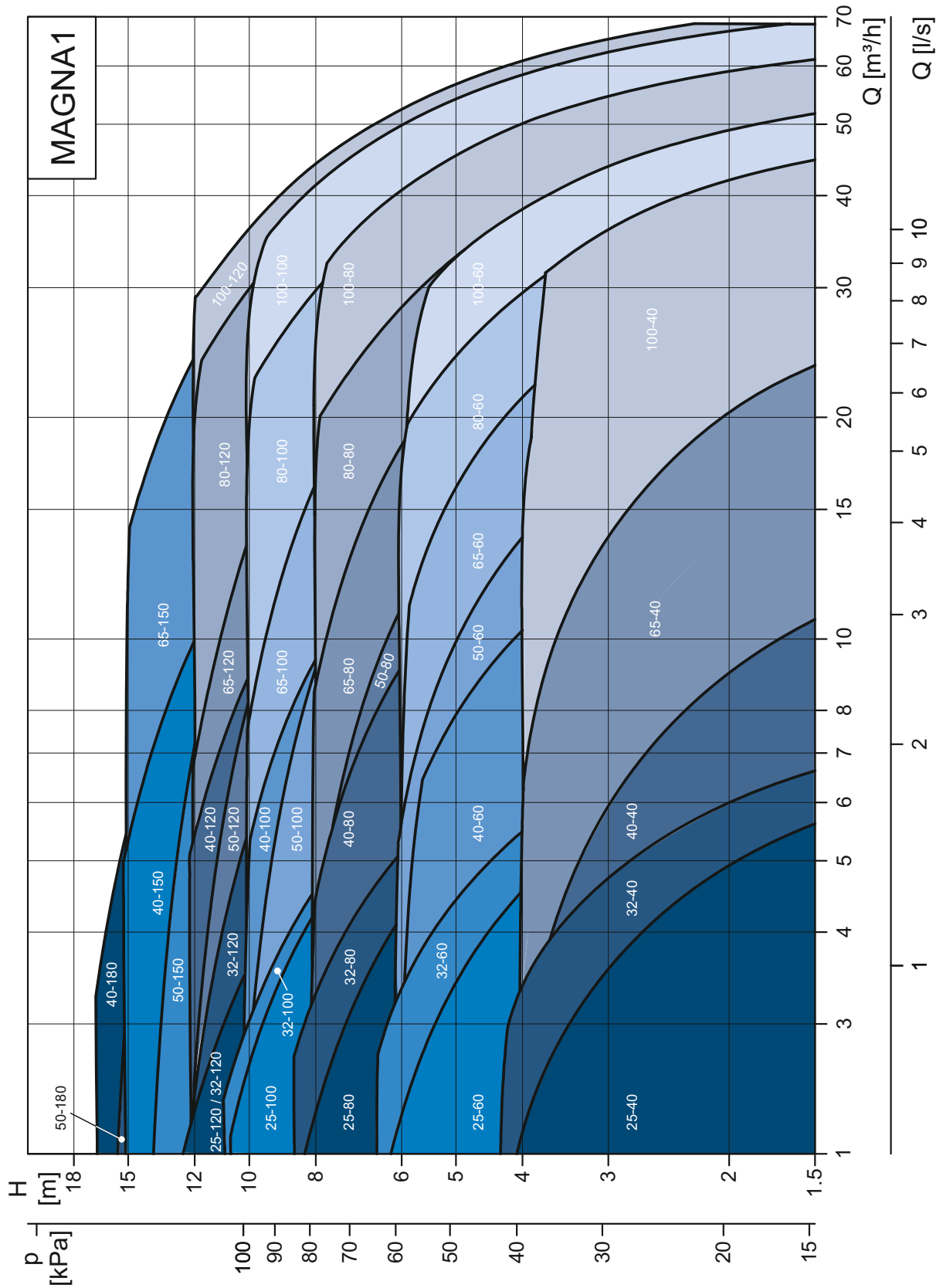

TM07 0263

Fig. 3 Performance range, MAGNA1

Performance range, MAGNA1 D, single-head operation

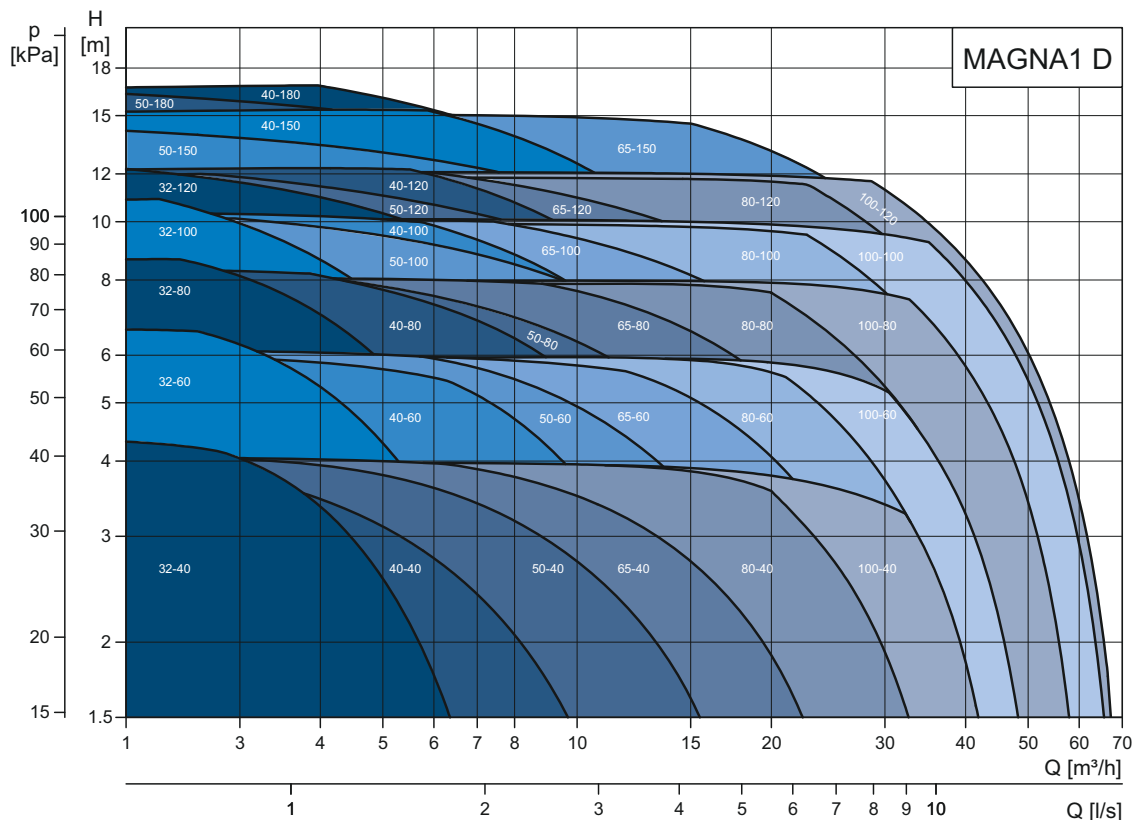

TM05 6373 4612

Performance range, MAGNA1 D, twin-head operation

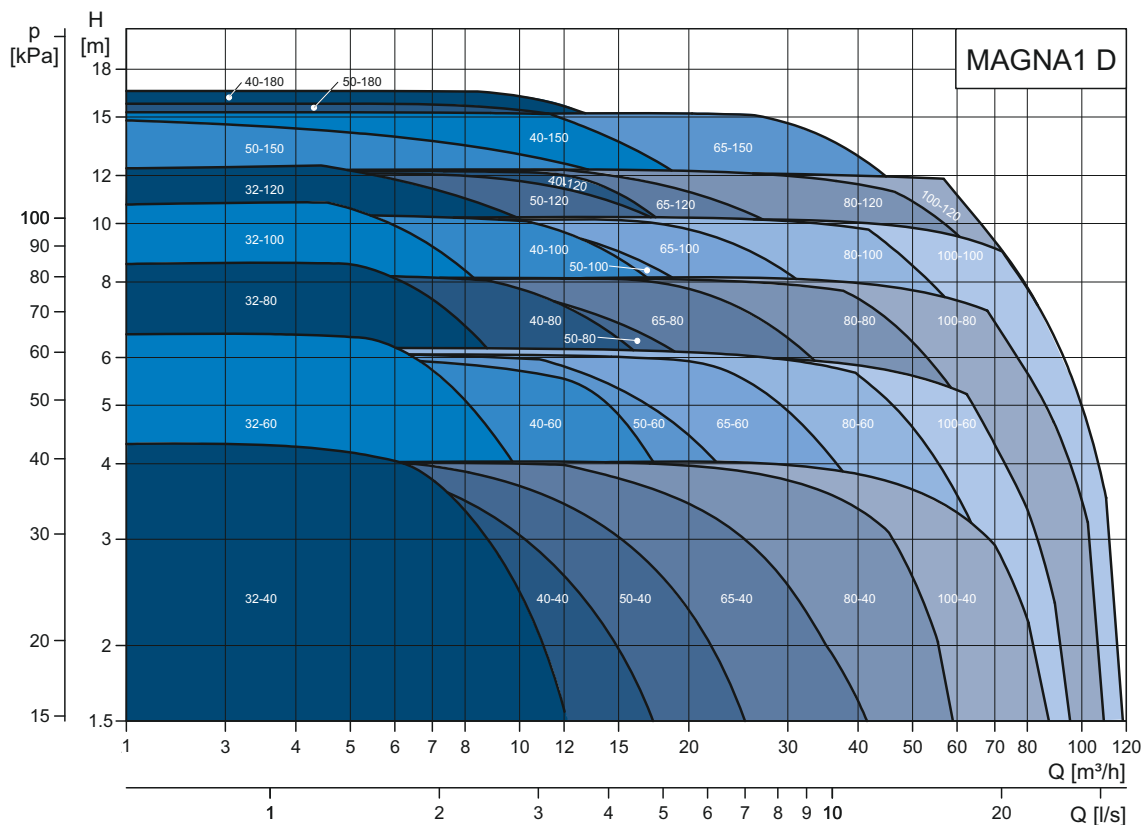

TM05 6374 4612

Product range

Single-head pumps

Pump type	Port-to-port length [mm]	Threaded pipe connection			Data sheet, page
		Cast iron		Stainless steel	
		PN 10	PN 16	PN 10	
MAGNA1 25-40 (N)	180	•	•	•	26
MAGNA1 25-60 (N)	180	•	•	•	27
MAGNA1 25-80 (N)	180	•	•	•	28
MAGNA1 25-100 (N)	180	•	•	•	29
MAGNA1 25-120 (N)	180	•	•	•	30
MAGNA1 32-40 (N)	180	•	•	•	31
MAGNA1 32-60 (N)	180	•	•	•	33
MAGNA1 32-80 (N)	180	•	•	•	35
MAGNA1 32-100 (N)	180	•	•	•	37
MAGNA1 32-120 (N)	180	•	•	•	39

Pump type	Port-to-port length [mm]	Flange connection					Data sheet, page
		Cast iron				Stainless steel	
		PN 6	PN 10	PN 16	PN 6/10	PN 6/10	
MAGNA1 32-120 F (N)	220			•	•	•	48
MAGNA1 40-40 F (N)	220			•	•	•	50
MAGNA1 40-60 F (N)	220			•	•	•	52
MAGNA1 40-80 F (N)	220			•	•	•	54
MAGNA1 40-100 F (N)	220			•	•	•	56
MAGNA1 40-120 F (N)	250			•	•	•	58
MAGNA1 40-150 F (N)	250			•	•	•	60
MAGNA1 40-180 F (N)	250			•	•	•	62
MAGNA1 50-60 F (N)	240			•	•	•	65
MAGNA1 50-80 F (N)	240			•	•	•	67
MAGNA1 50-100 F (N)	280			•	•	•	69
MAGNA1 50-120 F (N)	280			•	•	•	71
MAGNA1 50-150 F (N)	280			•	•	•	73
MAGNA1 50-180 F (N)	280			•	•	•	75
MAGNA1 65-40 F (N)	340			•	•	•	77
MAGNA1 65-60 F (N)	340			•	•	•	79
MAGNA1 65-80 F (N)	340			•	•	•	81
MAGNA1 65-100 F (N)	340			•	•	•	83
MAGNA1 65-120 F (N)	340			•	•	•	85
MAGNA1 65-150 F (N)	340			•	•	•	87
MAGNA1 80-60 F	360	•	•	•			90
MAGNA1 80-80 F	360	•	•	•			92
MAGNA1 80-100 F	360	•	•	•			94
MAGNA1 80-120 F	360	•	•	•			96
MAGNA1 100-40 F	450	•	•	•			98
MAGNA1 100-60 F	450	•	•	•			100
MAGNA1 100-80 F	450	•	•	•			102
MAGNA1 100-100 F	450	•	•	•			104
MAGNA1 100-120 F	450	•	•	•			106

Note: For further information about the product numbers of the various pump variants, see page [115](#).

Twin-head pumps

Pump type	Port-to-port length [mm]	Threaded pipe connection		Data sheet, page
		Cast iron		
		PN 10	PN 16	
MAGNA1 D 32-40	180	•	•	32
MAGNA1 D 32-60	180	•	•	34
MAGNA1 D 32-80	180	•	•	36
MAGNA1 D 32-100	180	•	•	38

Pump type	Port-to-port length [mm]	Flange connection				Data sheet, page
		Cast iron				
		PN 6	PN 10	PN 16	PN 6/10	
MAGNA1 D 32-120 F	220			•	•	49
MAGNA1 D 40-40 F	220			•	•	51
MAGNA1 D 40-60 F	220			•	•	53
MAGNA1 D 40-80 F	220			•	•	55
MAGNA1 D 40-100 F	220			•	•	57
MAGNA1 D 40-120 F	250			•	•	59
MAGNA1 D 40-150 F	250			•	•	61
MAGNA1 D 40-180 F	250			•	•	63
MAGNA1 D 50-40 F	240			•	•	64
MAGNA1 D 50-60 F	240			•	•	66
MAGNA1 D 50-80 F	240			•	•	68
MAGNA1 D 50-100 F	280			•	•	70
MAGNA1 D 50-120 F	280			•	•	72
MAGNA1 D 50-150 F	280			•	•	74
MAGNA1 D 50-180 F	280			•	•	76
MAGNA1 D 65-40 F	340			•	•	78
MAGNA1 D 65-60 F	340			•	•	80
MAGNA1 D 65-80 F	340			•	•	82
MAGNA1 D 65-100 F	340			•	•	84
MAGNA1 D 65-120 F	340			•	•	86
MAGNA1 D 65-150 F	340			•	•	88
MAGNA1 D 80-40 F	360	•	•	•		89
MAGNA1 D 80-60 F	360	•	•	•		91
MAGNA1 D 80-80 F	360	•	•	•		93
MAGNA1 D 80-100 F	360	•	•	•		95
MAGNA1 D 80-120 F	360	•	•	•		97
MAGNA1 D 100-40 F	450	•	•	•		99
MAGNA1 D 100-60 F	450	•	•	•		101
MAGNA1 D 100-80 F	450	•	•	•		103
MAGNA1 D 100-100 F	450	•	•	•		105
MAGNA1 D 100-120 F	450	•	•	•		107

Note: For more information about the product numbers of the various pump variants, see page [115](#).

A quick guide to pump selection

Before sizing and selecting your pump, make sure that the pump's operating conditions are fulfilled:

- liquid quality and temperature
- ambient conditions
- minimum inlet pressure
- maximum operating pressure

See section 3. *Operation*.

Pump size

In order to choose a pump for a heating system, it is necessary to know both the system characteristics and the pump curve. The pump is dimensioned so it can provide an adequate performance at the maximum system load.

Determining the size of your pump depends on the following:

- the required maximum flow rate (Q).
- the maximum pressure loss in the system (H).

By marking the values in a curve chart, you find your duty point. The x-axis shows the flow rate (Q), while the y-axis shows the pressure (H). See fig. 4.

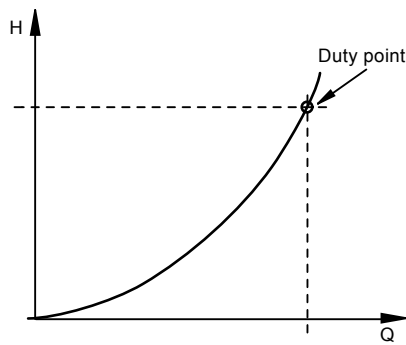
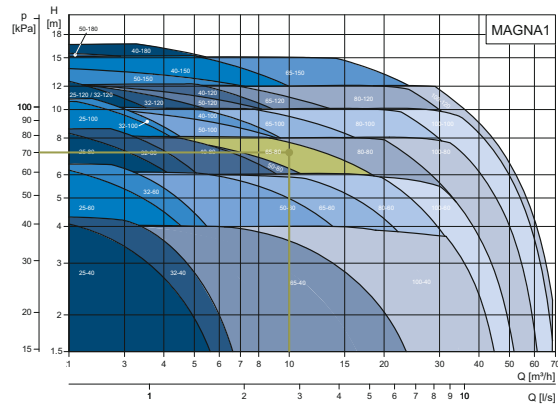

Fig. 4 System characteristic

TMD2 2040 3301

Go to *Performance range, MAGNA1*, and mark your duty point. The field in which your duty point is placed, is an indication of which pump is best suited for your application. See fig. 5.



TMD070322

Fig. 5 Pump selection

Find the specific pump data in the section 7. *Performance curves and technical data*. This information will help you determine whether you have found the correct pump size or not.

Note: To ensure an efficient operation it is important not to oversize the pump. All pumps have a "best point" (η_{max}), indicating where the pump is working most efficiently. When operating at your duty point, the pump must work in the most efficient Q and H area.

System applications

Heating systems

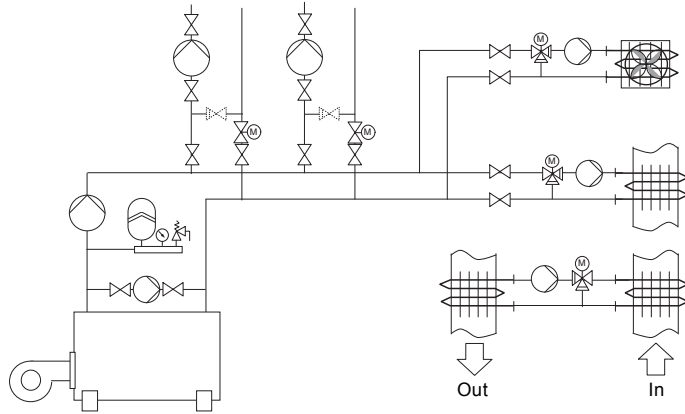

- One- and two-pipe heating systems
- main pumps
- zone pumps
- mixing loops
- boiler shunt pumps
- pumps for heating surfaces
- calorifiers
- underfloor heating systems
- solar-heating systems
- ground-source heat-pump systems
- heat recovery systems.

TM01 0188 0697

Domestic hot-water systems

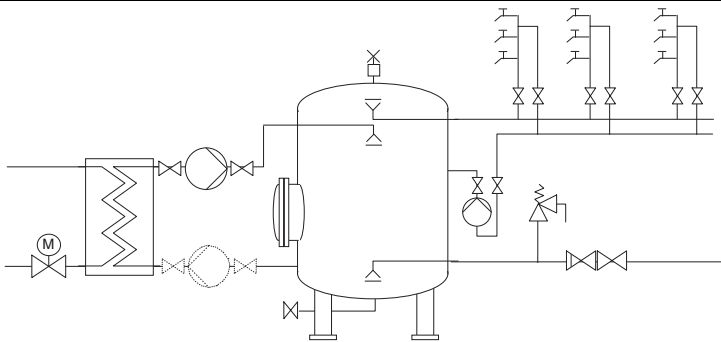

- Domestic hot-water systems

TM01 0188 0697

Air-conditioning and cooling systems

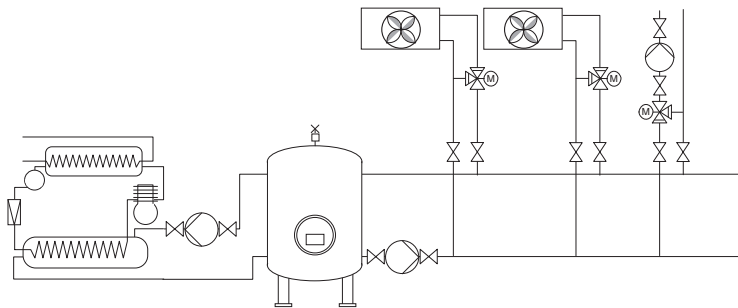

- Two-pipe air-conditioning systems
- main pumps
- zone pumps
- pumps for refrigeration units
- heat pump systems
- ground-source heat-pump systems
- heat recovery systems
- air-conditioning surfaces.

TM01 0170 0697

2. Construction

MAGNA1 is of the canned-rotor type, which means that pump and motor form an integral unit without shaft seal and with only two gaskets for sealing. The bearings are lubricated by the pumped liquid.

The pump is characterised by the following:

- controller integrated in the control box
- operating panel on the control box
- twin-head versions
- no external motor protection required
- insulating shells supplied with single-head pumps for heating systems.

Motor and electronic controller

The pump incorporates a 4-pole synchronous, permanent-magnet motor (PM motor). This motor type is characterised by higher efficiency than a conventional asynchronous squirrel-cage motor.

The pump speed is controlled by an integrated frequency converter.

Pump connections

Threaded pipe connections according to ISO 228-1.

Flange dimensions according to EN 1092-2.

Surface treatment

The pump housing and pump head are electrocoated to improve the corrosion resistance.

Electrocoating includes:

- alkaline cleaning
- pretreatment with zinc phosphate coating
- cathodic electrocoating (epoxy)
- curing of paint film at 200-250 °C.

The pump housing of stainless-steel versions is not treated and painted and appears in blank steel. See fig. 6.



TMD05 9282 3613

Fig. 6 Stainless-steel version

Sectional drawings

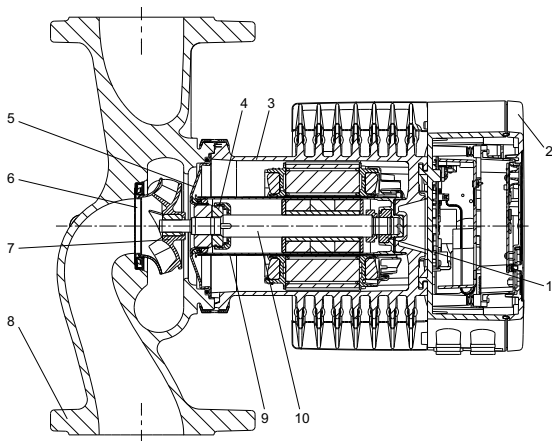

TM06 9997 3917

Fig. 7 Terminal-connected version with PPS composite rotor can

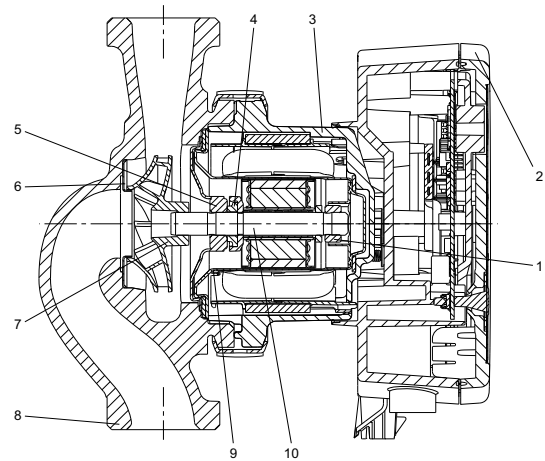

TM06 9947 3917

Fig. 8 Plug-connected version with stainless-steel rotor can

Material specification

See figs 7 and 8.

Rotor can materials

Pos.	Component	Material	EN
1	Outer bearing ring	Aluminium oxide	
2	Control box	Polycarbonate	
3	Stator housing	Aluminium	
	O-rings and gaskets	EPDM	
4	Thrust bearing	Aluminium oxide or carbon	
5	Bearing plate	Stainless steel	EN 1.4301
6	Neck ring	Stainless steel	EN 1.4301
7	Impeller	PES	
8	Pump housing	Cast iron or stainless steel	EN 1561 EN-GJL-250/EN 1.4408
9	Rotor can	PPS or stainless steel	
10	Shaft	Ceramics, plug connected versions	
10	Shaft	Stainless steel, terminal-connected versions	EN 1.4404

3. Operation

Operating conditions

General recommendations

Water in heating systems	Water quality according to local standards such as the German standard VDI 2035
Water containing glycol	Maximum viscosity = 10-50 cSt ~ 50 % water and 50 % glycol at -10 °C

Liquid temperature

-10 to 110 °C.

Location

The pump is designed for indoor installation.

Always install the pump in an dry environment where it will not be exposed to drops or splashes, for example water, from surrounding equipment or structures.

As the pump contains stainless-steel parts, it is important that it is not installed directly in environments, such as:

- Indoor swimming pools where the pump would be exposed to the ambient environment of the pool.
- Locations with direct and continuous exposure to a marine atmosphere.
- In rooms where hydrochloric acid (HCl) can form acidic aerosols escaping from, for example, open tanks or frequently opened or vented containers.

The above applications do not disqualify for installation of MAGNA1. However, it is important that the pump is not installed directly in these environments.

Ambient conditions

Ambient temperature during operation	0-40 °C
Ambient temperature during storage and transport	-40 to 70 °C
Relative humidity	Maximum 95 %

Maximum operating pressure

PN 6: 6 bar or 0.6 MPa.

PN 10: 10 bar or 1.0 MPa.

PN 16: 16 bar or 1.6 MPa.

Minimum inlet pressure

The following relative minimum inlet pressure must be available at the pump inlet during operation to avoid cavitation noise and damage to the pump bearings.

Note: The values in the table below apply to single-head pumps and twin-head pumps in single-head operation.

Single-head pumps DN	Liquid temperatures		
	75 °C	95 °C	110 °C
	Inlet pressure [bar] / [MPa]		
25-40/60/80/100/120	0.10 / 0.01	0.35 / 0.035	1.0 / 0.10
32-40/60/80/100/120	0.10 / 0.01	0.35 / 0.035	1.0 / 0.10
32-120 F	0.10 / 0.01	0.20 / 0.020	0.7 / 0.07
40-40/60 F	0.10 / 0.01	0.35 / 0.035	1.0 / 0.10
40-80/100/120/150/180 F	0.10 / 0.01	0.50 / 0.05	1.0 / 0.10
50-60/80 F	0.10 / 0.01	0.40 / 0.04	1.0 / 0.10

Single-head pumps DN	Liquid temperatures		
	75 °C	95 °C	110 °C
	Inlet pressure [bar] / [MPa]		
50-100/120 F	0.10 / 0.01	0.50 / 0.05	1.0 / 0.10
50-150/180 F	0.70 / 0.07	1.20 / 0.12	1.7 / 0.17
65-40/60/80/100/120/150 F	0.70 / 0.07	1.20 / 0.12	1.7 / 0.17
80-60/80/100/120 F	0.50 / 0.05	1.00 / 0.10	1.5 / 0.15
100-40/60/80/100/120 F	0.70 / 0.07	1.20 / 0.12	1.7 / 0.17

In the case of manual synchronous operation, the required relative inlet pressure must be increased by 0.1 bar or 0.01 MPa compared to the stated values for single-head pumps or twin-head pumps in single-head operation.

Note: The actual inlet pressure plus pump pressure against a closed valve must be lower than the maximum permissible system pressure.

The relative minimum inlet pressures apply to pumps installed up to 300 metres above sea level. For altitudes above 300 metres, the required relative inlet pressure must be increased by 0.01 bar or 0.001 MPa per 100 metres altitude. The pump is only approved for an altitude of 2000 metres above sea level.

Sound pressure level

The sound pressure level of the pump is dependent on the power consumption. Levels are determined in accordance with ISO 3745 and ISO 11203, method Q2.

Pump size	Max dB(A)
25-40/60/80/100/120	39
32-40/60/80/100/120	
40-40/60	
50-40	
32-120 F	45
40-80/100	
50-60/80	
65-40/60	
80-40	
40-120/150/180	50
50-100/120/150/180	
65-80/100/120	
80-60/80	
100-40/60	
65-150	55
80-100/120	
100-80/100/120	

Closed valve operation

The pump can operate at any speed against a closed valve for several days without damage to the pump. However, Grundfos recommends you to operate at the lowest possible speed curve to minimise energy losses. There are no minimum flow requirements.

Note: Do not close inlet and outlet valves simultaneously, always keep one open when the pump is running. Media and ambient temperatures must never exceed the specified temperature range.

Pumped liquids

The pump is suitable for thin, clean, non-aggressive liquids, not containing solid particles or fibres that may attack the pump mechanically or chemically.

In heating systems, the water must meet the requirements of accepted standards on water quality in heating systems, for example the German standard VDI 2035.

In domestic hot-water systems, we recommend that you keep the liquid temperature below 65 °C to eliminate the risk of lime precipitation.

Do not use the pump for flammable, combustible or explosive liquids, such as diesel oil and petrol.

Do not use the pump for aggressive liquids, such as acids and seawater.

If the pump is not used during periods of frost, take the necessary steps to prevent frost bursts.

Additives with a density or kinematic viscosity higher than that of water will reduce the hydraulic performance.

Do not use additives that in any way can or will disturb the functionality of the pump.

Whether a pump is suitable for a particular liquid depends on a number of factors of which the most important are lime content, pH value, temperature and content of solvents and oils.

You can use the pump for pumping water or glycol mixtures up to 50 %. See section [General recommendations](#) on page 13.

The pumping of glycol mixtures reduces the hydraulic performance.

Electrical data

Pump type	MAGNA1 (D).
Enclosure class	IPX4D (EN 60529).
Insulation class	F.
Supply voltage	1 x 230 V ± 10 %, 50/60 Hz, PE.
Digital input	External potential-free contact. Contact load: 5 V, 10 mA. Screened cable. Loop resistance: Maximum 130 Ω.
Relay output	Maximum load: 250 V, 2 A, AC1. Minimum load: 5 VCD, 20 mA. Screened cable, depending on signal level.
Leakage current	$I_{\text{leakage}} < 3.5 \text{ mA}$. The leakage current is measured in accordance with EN 60335-1.
EMC	EN 55014-1:2006, EN 55014-2:1998, EN 61000-3-3:2013 and EN 61000-3-2:2006.

4. Installation

Mechanical installation

The pump is designed for indoor installation.

The pump must be installed with horizontal motor shaft.

The pump may be installed in horizontal as well as vertical pipes.

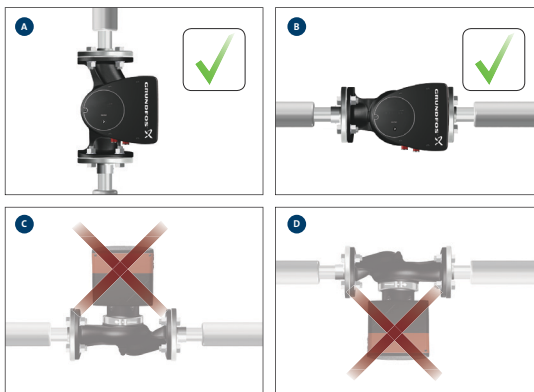

Fig. 9 Installation positions

Arrows on the pump housing indicate the liquid flow direction through the pump.

The control box must be in the horizontal position with the Grundfos logo in the vertical position. See fig. 9.

This is described in the installation and operating instructions, which will be released together with the product launch.



net.grundfos.com/qr/i/99209952

The pump must be installed in such a way that it is not stressed by the pipes.

The pump may be suspended directly in the pipes, provided that the pipes can support the pump.

Twin-head pumps are prepared for installation on a mounting bracket or base plate.

To ensure adequate cooling of motor and electronics, the following must be observed:

- Make sure that the control box is in horizontal position with the Grundfos logo in vertical position. The ambient temperature must not exceed 40 °C.

Insulating shells

The insulating shells supplied with single-head pumps are for heating systems and must be fitted as part of the installation.

Insulating shells for pumps for air-conditioning and cooling systems are available as an accessory.

See section *Insulating kits for air-conditioning and cooling systems* on page 108.

Note: Insulating shells are not available for twin-head pumps.

Electrical installation

The electrical connection and protection must be carried out in accordance with local regulations.

- The pump must be connected to an external main switch.
- The pump must always be correctly earthed.
- The pump requires no external motor protection.
- The pump incorporates thermal protection against slow overloading and blocking.
- When switched on via the power supply, the pump will start pumping after approximately 5 seconds.

Note: The number of starts and stops via the power supply must not exceed four times per hour.

The main connection of the pump must be made as shown in fig. 10 on page 16.

Cables

All cables used must be connected in accordance with local regulations.

Additional protection

If the pump is connected to an electric installation where an earth leakage circuit breaker (ELCB), residual-current device (RCD) or residual-current circuit device (RCCB) is used as an additional protection, this circuit breaker must trip when earth fault currents with DC content (pulsating DC) occur.

The earth leakage circuit breaker must be marked with the first or both of the symbols shown below:

Symbol	Description
	High-sensitivity ELCB, type A, according to IEC 60775
	High-sensitivity ELCB, type B, according to IEC 60775

TM05 5518 3812

QR 99209952

Wiring diagrams

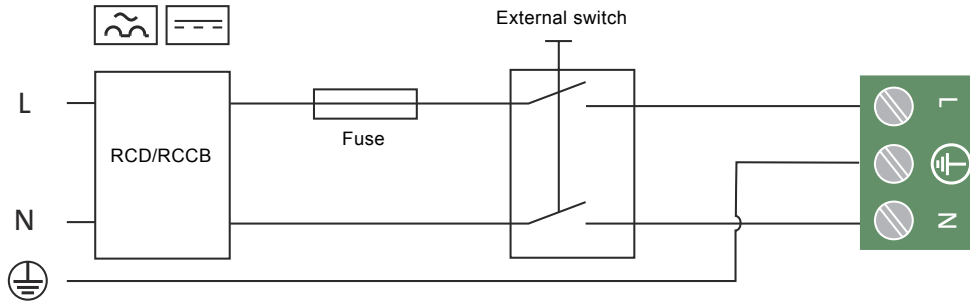

Fig. 10 Example of terminal connection, 1 x 230 V ± 10 %, 50/60 Hz, PE

TM03 2397 3712

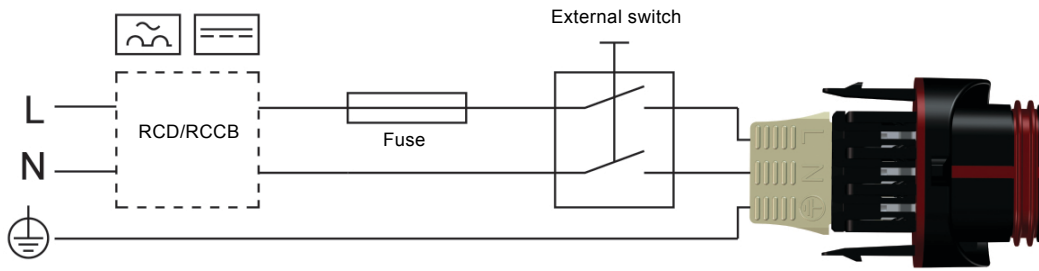

Fig. 11 Example of a plug-connected motor with main switch, backup fuse and additional protection

TM05 5277 3712

Connection to external control

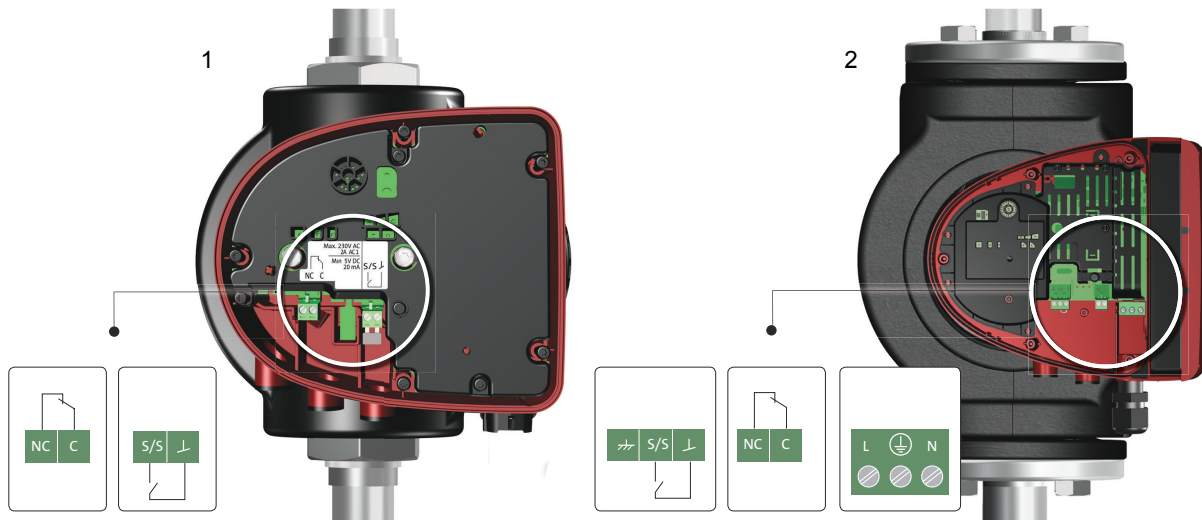

Fig. 12 External control connections in the control box

TM06 9079 3617

Pos.	Description
1	Plug-connected versions
2	Terminal-connected versions

Digital input

You can use the digital input for external control of start/stop.

Note: If no external on/off switch is connected, maintain the jumper between terminals Start/Stop (S/S) and frame (\perp). This connection is the factory setting.

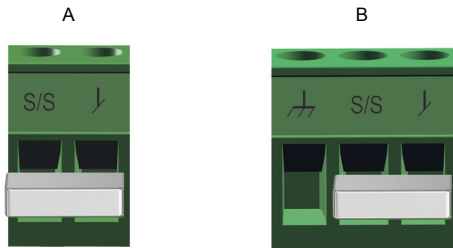

TM06 8041 0317 / TM06 9080 3617

Fig. 13 Digital input in the control box
A: Plug-connected versions
B: Terminal-connected versions

Contact symbol	Function
S/S	Start/Stop
\perp	Frame connection
$\text{—} \diagup \text{—}$	Cable shield

Start/Stop

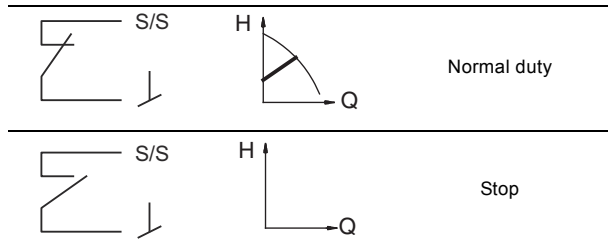

For more information on communication, see section [External control and monitoring](#) on page 22.

Relay output

The relay output is used as a fault signal.



TM06 8041 0317

Fig. 14 Relay output in the control box

Contact symbol	Function
NC	Normally closed
C	Common

The functions of the signal relay are as shown in the table below:

Signal relay	Alarm signal
	Not activated: <ul style="list-style-type: none"> The power supply has been switched off. The pump has not registered a fault.
	Activated: <ul style="list-style-type: none"> The pump has registered a fault or there is a wirebreak.

For more information on communication, see section [External control and monitoring](#) on page 22.

5. Control and communication

	Models A and B	Model C	Page
Control modes			
Proportional pressure	•	•	18
Constant pressure	•	•	
Constant curve	•	•	
Twin-head pump function			
Alternating operation		•	20
External control and monitoring			
Digital input		•	22
Relay output		•	
Communication			
Grundfos GO Remote		•	21

Control modes

Proportional-pressure curve (PP1, PP2 or PP3)

Proportional-pressure control adjusts the pump performance to the actual flow demand in the system, but the pump performance follows the selected performance curve, PP1, PP2 or PP3. See fig. 15 where PP2 has been selected.

For further information, see section [Control modes](#) on page 18.

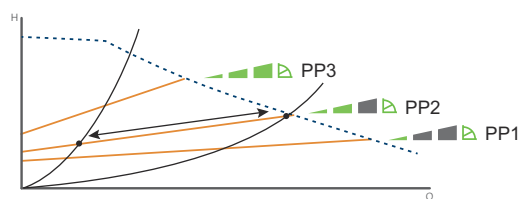

TM05 5555 3812

Fig. 15 Three proportional-pressure curves or settings

The selection of the right proportional-pressure setting depends on the characteristics of the system in question and the actual flow demand.

Constant-pressure curve (CP1, CP2 or CP3)

Constant-pressure control adjusts the pump performance to the actual flow demand in the system, but the pump performance follows the selected performance curve, CP1, CP2 or CP3. See fig. 16 where CP1 has been selected.

For further information, see section [Control modes](#) on page 18.

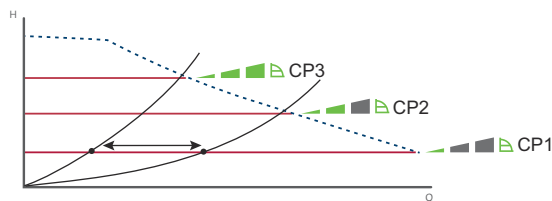

TM05 5556 3812

Fig. 16 Three constant-pressure curves or settings

The selection of the right constant-pressure setting depends on the characteristics of the system in question and the actual flow demand.

Constant curve or constant speed (I, II or III)

In constant-curve or constant-speed operation, the pump runs at a constant speed, independent of the actual flow demand in the system. The pump performance follows the selected performance curve, I, II or III. See fig. 17 where II has been selected.

For further information, see section [Control modes](#) on page 18.

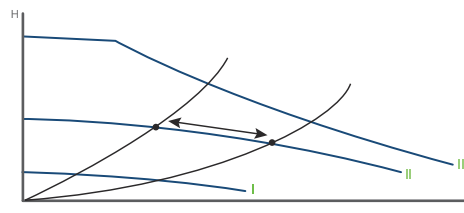

TM05 5557 3812

Fig. 17 Three constant-curve or constant-speed settings

The selection of the right constant-curve or constant-speed setting depends on the characteristics of the system in question.

Overview of the control modes

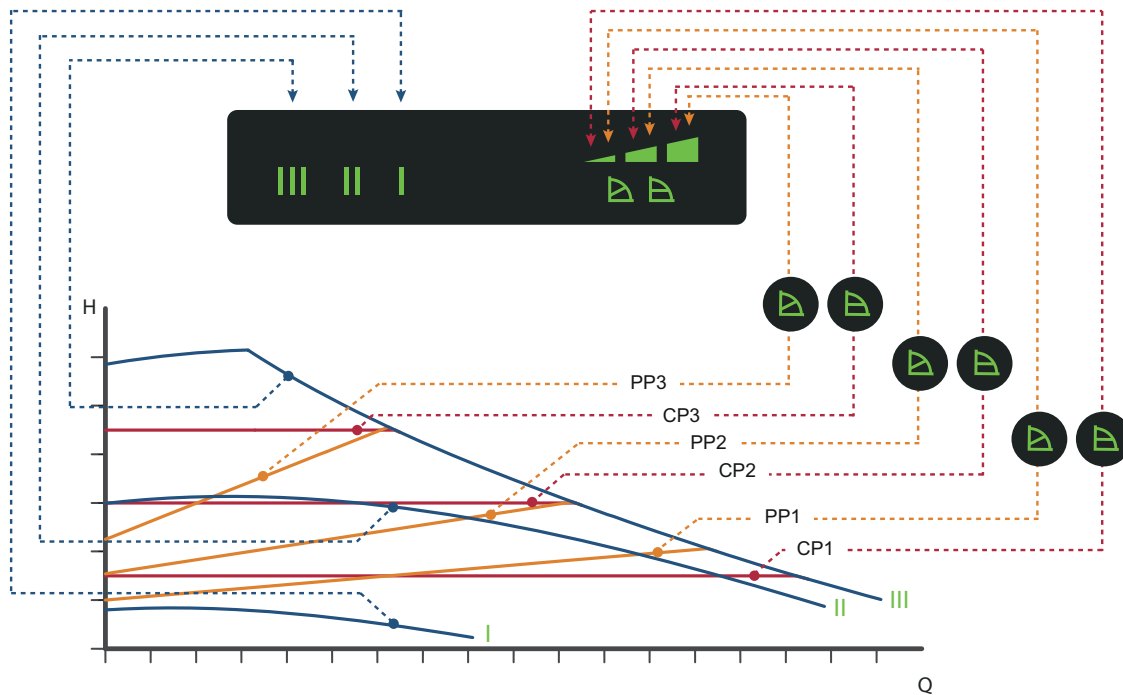

TM05 2776 3617

Fig. 18 Control mode in relation to system requirements

Setting	Pump curve	Function
PP1	Lowest proportional-pressure curve	The duty point of the pump will move up or down on the lowest proportional-pressure curve, depending on the flow demand. The head (pressure) is reduced at falling heat demand and increased at rising flow demand.
PP2	Intermediate proportional-pressure curve	The duty point of the pump will move up or down on the intermediate proportional-pressure curve, depending on the flow demand. The head (pressure) is reduced at falling flow demand and increased at rising flow demand.
PP3	Highest proportional-pressure curve	The duty point of the pump will move up or down on the highest proportional-pressure curve, depending on the flow demand. The head (pressure) is reduced at falling flow demand and increased at rising flow demand.
CP1	Lowest constant-pressure curve	The duty point of the pump will move out or in on the lowest constant-pressure curve, depending on the flow demand in the system. The head (pressure) is kept constant, irrespective of the flow demand.
CP2	Intermediate constant-pressure curve	The duty point of the pump will move out or in on the intermediate constant-pressure curve, depending on the flow demand in the system. The head (pressure) is kept constant, irrespective of the flow demand.
CP3	Highest constant-pressure curve	The duty point of the pump will move out or in on the highest constant-pressure curve, depending on the flow demand in the system. The head (pressure) is kept constant, irrespective of the flow demand.
III	Speed III	The pump runs on a constant curve which means that it runs at a constant speed. At speed III, the pump is set to run on the maximum curve under all operating conditions. Quick venting of the pump can be obtained by setting the pump to speed III for a short period.
II	Speed II	The pump runs on a constant curve which means that it runs at a constant speed. At speed II, the pump is set to run on the intermediate curve under all operating conditions.
I	Speed I	The pump runs on a constant curve which means that it runs at a constant speed. At speed I, the pump is set to run on the minimum curve under all operating conditions.

Selecting control mode

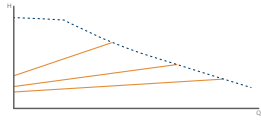
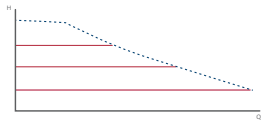
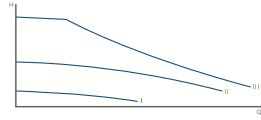
System application	Select this control mode
<p>In systems with relatively large pressure losses in the distribution pipes and in air-conditioning and cooling systems.</p> <ul style="list-style-type: none"> Two-pipe heating systems with thermostatic valves and <ul style="list-style-type: none"> very long distribution pipes strongly throttled balancing valves differential-pressure regulators large pressure losses in those parts of the system through which the total quantity of water flows, for example a boiler, a heat exchanger and a distribution pipe up to the first branching. Primary circuit pumps in systems with large pressure losses in the primary circuit. Air-conditioning systems with <ul style="list-style-type: none"> heat exchangers (fan coils) cooling ceilings cooling surfaces. 	<p>Proportional pressure</p> 
<p>In systems with relatively small pressure losses in the distribution pipes.</p> <ul style="list-style-type: none"> Two-pipe heating systems with thermostatic valves and <ul style="list-style-type: none"> dimensioned for natural circulation small pressure losses in those parts of the system through which the total quantity of water flows, for example a boiler, a heat exchanger and a distribution pipe up to the first branching or <ul style="list-style-type: none"> modified to a high differential temperature between the flow pipe and return pipe, for example district heating. Underfloor heating systems with thermostatic valves. One-pipe heating systems with thermostatic valves or pipe balancing valves. Primary circuit pumps in systems with small pressure losses in the primary circuit. 	<p>Constant pressure</p> 
<p>For operation according to the maximum or minimum curve, like an uncontrolled pump:</p> <ul style="list-style-type: none"> Use the maximum curve mode in periods in which a maximum flow rate is required. This operating mode is for instance suitable for hot-water priority in domestic hot-water systems. Use the minimum curve mode in periods in which a minimum flow rate is required. 	<p>Constant curve</p> 

Twin-head pump function

The twin-head pump function allows you to control twin-head pumps without the use of an external controller. The pumps operate in alternating mode, meaning that only one pump runs at a time. The two pumps communicate with each other via wireless connection and change from one pump to the other every 24 hours or if one of the pumps experiences an alarm.

Operating panel

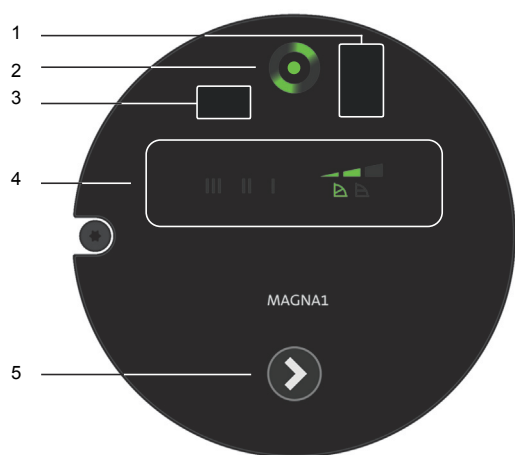

TM06 9078 3617

Fig. 19 Operating panel at first startup

The operating panel on the pump comprises the following:

Pos.	Description
1	Infrared receiver, Grundfos GO MAGNA1 25-40 - 32-120
2	Grundfos Eye operating status.
3	Infrared receiver, Grundfos GO MAGNA1 32-40 F - 100-120 F
4	LED indication of the control mode
5	Push-button for selection of a control mode.

Grundfos Eye

Grundfos Eye is on when the power supply has been switched on. See 1 in fig. 19.

Grundfos Eye is an indicator light providing information about the actual pump status.

The indicator light will flash in different sequences and provide information about the following:

- power on or off
- pump running or stopped
- pump alarms
- twin-head connection.

LEDs indicating the control mode

The pump has nine optional performance settings which you can select with the push-button. See 3 in fig. 19.

The control mode is indicated by the LEDs in the display. The pump is factory set to proportional-pressure (PP2).

Button presses	Active light fields	Description
0		Intermediate proportional-pressure curve, referred to as PP2 Factory setting
1		Highest proportional-pressure curve, referred to as PP3
2		Lowest constant-pressure curve, referred to as CP1
3		Intermediate constant-pressure curve, referred to as CP2
4		Highest constant-pressure curve, referred to as CP3
5		Constant curve or constant speed III
6		Constant curve or constant speed II
7		Constant curve or constant speed I
8		Lowest proportional-pressure curve, referred to as PP1

Communication

Grundfos GO Remote

MAGNA1 single-head pumps are designed for infrared communication (IR) with Grundfos GO Remote, while MAGNA1 twin-head pumps can also communicate via radio.

You can use Grundfos GO Remote for the following:

- Adjusting the setpoint of the proportional-pressure curve
- Managing the fault-relay trigger setting in twin-head pumps
- Reading of warning and alarm indications.

MAGNA1 also enables communication via the following:

- digital input (start/stop)
- relay output.

For further information, see section [External control and monitoring](#) on page 22.

External control and monitoring

Monitoring and controlling your system decreases the overall system downtime, and MAGNA1 model C offers several ways of meeting this demand. If the pump experiences a fault, the alarm relay sends a signal to the controller, which will subsequently trigger further events depending on your chosen strategy. See fig. 20.

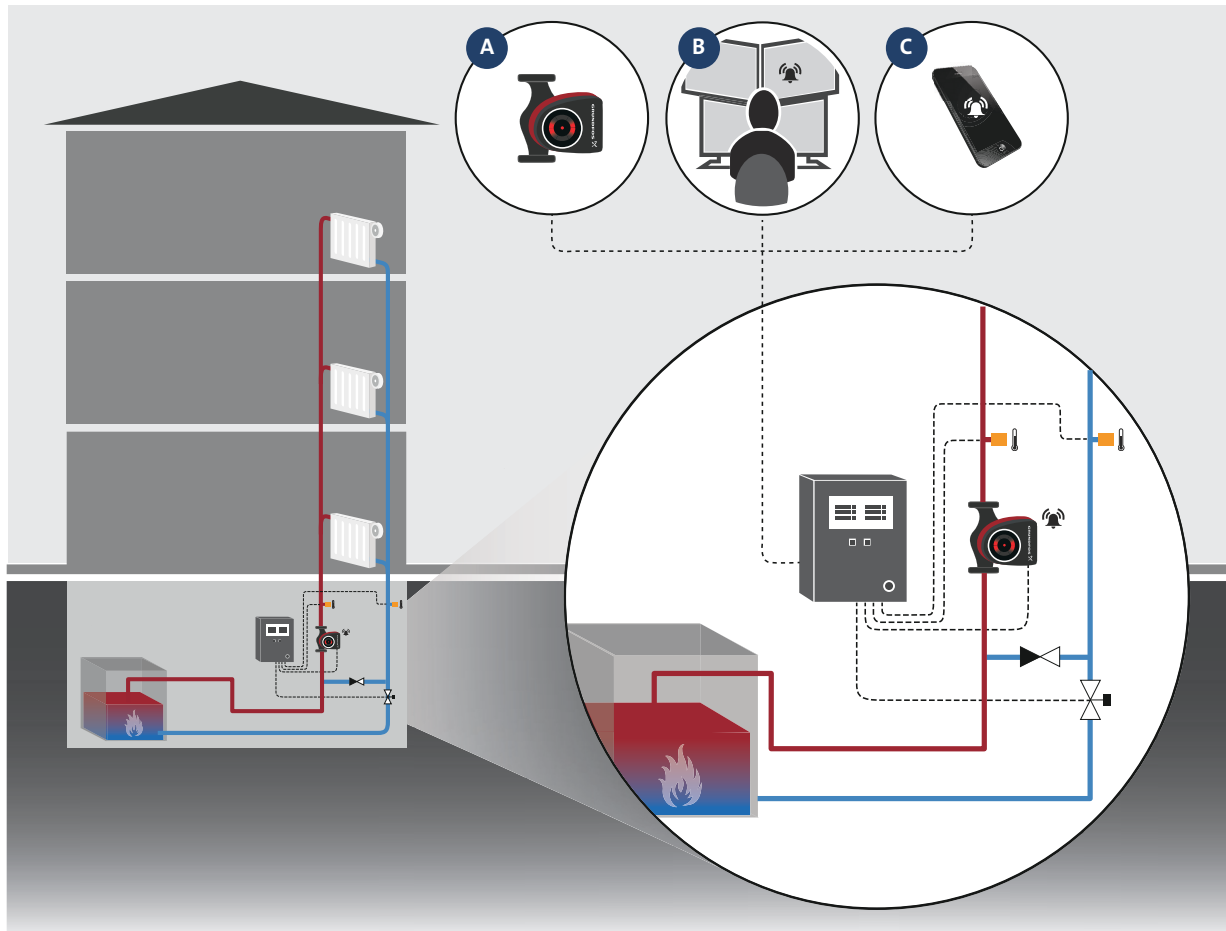

TM06 8040 0317

Fig. 20 External control and monitoring

A: Local control and monitoring

The alarm relay output from the pump can be used to trigger other actions locally in the system, for example stopping a boiler. Other components in the system can use the "no fault signal" as part of an overall startup routine. If a twin-head pump experiences a fault on one of its heads, MAGNA1 will immediately shift to the other head, ensuring continuous operation.

B: Digital integration

SCADA integration ensures continuous monitoring of the entire application, including any faults on the pump. By using the digital input, the pumps can be started and stopped remotely.

C: Remote notifications

In addition to local control and monitoring, it is possible to use the alarm relay output to receive fault notifications on mobile devices, as long as your building management system allows it.

For more information, see sections [Connection to external control](#) on page 16, [Digital input](#) on page 17, and [Relay output](#) on page 17.

6. Performance curves

How to read the curve charts

Each control mode has its own performance curve, QH curve. A power curve, P1 curve, is associated with each QH curve. The power curve shows the power consumption of the pump, P1, in watt at a given QH curve.

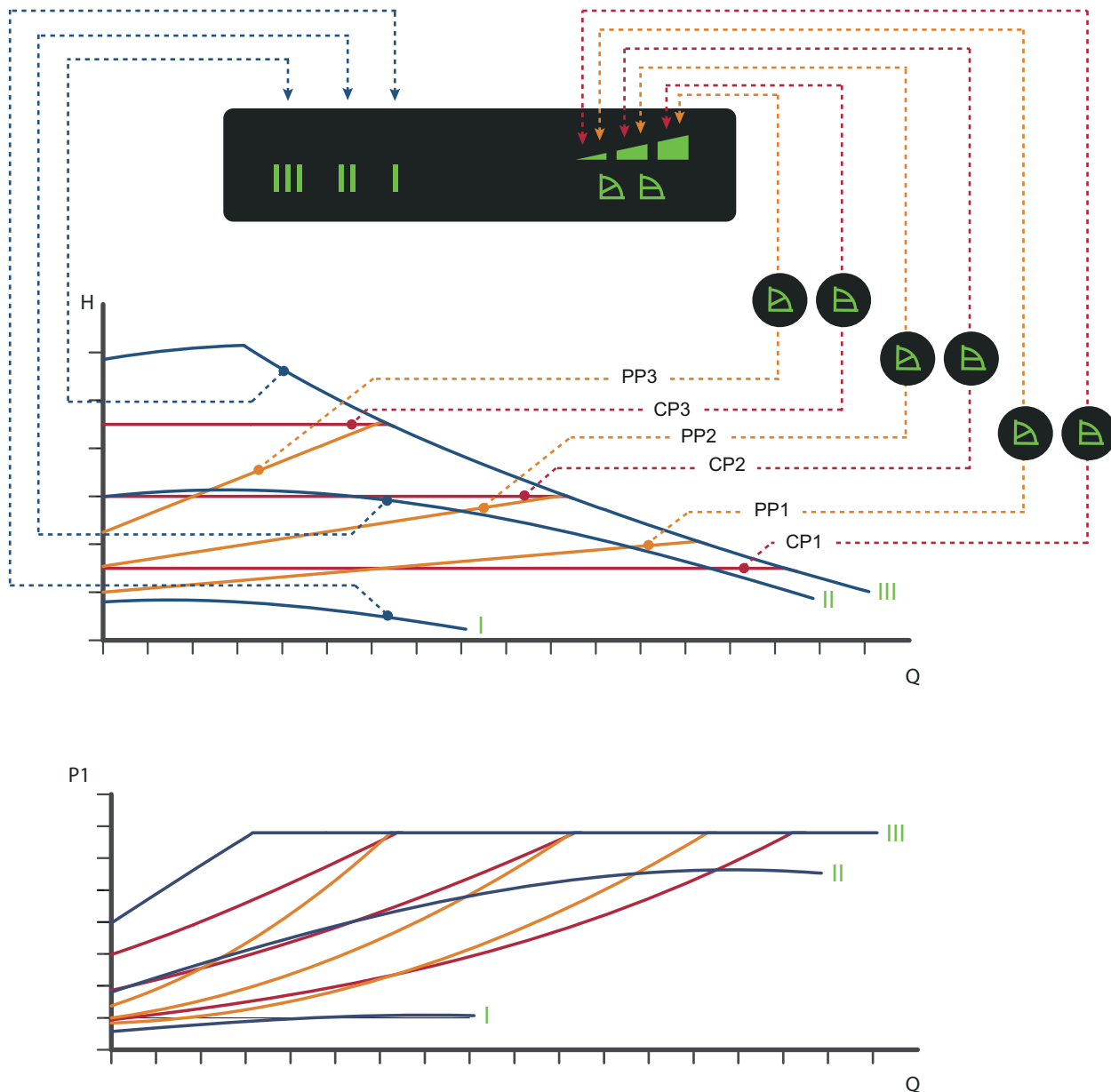

Fig. 21 Performance curves in relation to control modes

Setting	Pump curve
PP1	Lowest proportional-pressure curve
PP2	Intermediate proportional-pressure curve
PP3	Highest proportional-pressure curve
CP1	Lowest constant-pressure curve
CP2	Intermediate constant-pressure curve
CP3	Highest constant-pressure curve
III	Constant-curve duty, fixed speed III
II	Constant-curve duty, fixed speed II
I	Constant-curve duty, fixed speed I

TM05 2778 3617

Curve conditions

The guidelines below apply to the performance curves on pages 26 to 107:

- Test liquid: airless water.
- The curves apply to a density of $\rho = 998.2 \text{ kg/m}^3$ and a liquid temperature of $20 \text{ }^\circ\text{C}$.
- All curves show average values and must not be used as guarantee curves. If a specific minimum performance is required, make individual measurements.
- The curves apply to a kinematic viscosity of $\nu = 1.004 \text{ mm}^2/\text{s}$ (1.004 cSt).
- Reference supply voltage: 1 x 230 V, 50 Hz.
- Curves obtained according to EN 16297.

Symbols used on the following pages

The pump is energy-optimised and complies with the EuP Directive, Commission Regulation (EC) No 641/2009, which has been effective as from 1 January 2013.

For MAGNA1 model C single-head pumps, the energy efficiency index (EEI) is ≤ 0.20 .

Figure 22 shows the energy consumption index for a typical circulator pump compared to the various EEI limits.

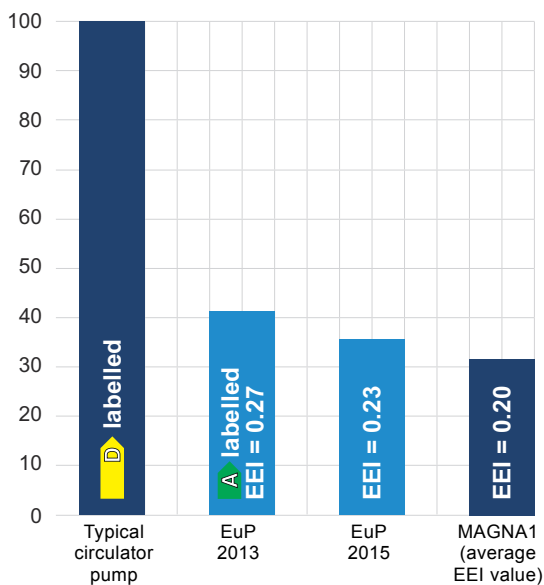

TM07 0028 3817

Fig. 22 Energy consumption index, single-head pumps

With an energy efficiency index (EEI) equal to the EuP 2015, you can achieve significant energy savings compared to a typical circulator pump and thus a remarkably fast return on investment.

Additional information

Use Grundfos GO Remote to scan the QR code on the pump and get the following information:

- product photo
- pump performance curves
- dimensional sketches
- wiring diagram
- quotation text
- technical data
- service parts list
- PDF files, such as data booklet and installation and operating instructions.



TM05 3826 1712

Fig. 23 QR code on the pump nameplate

Markings and approvals

The following marks are available after positive testing of the pump:

Mark	Description
	The EC marking is based on the declaration of conformity issued by the manufacturer who certifies that the product meets all the appropriate provisions of the relevant legislation implementing certain European Directives.
	Electro-technical products including products according to the Product Safety Act (ProdSG) and medical products according to the Medical Product Act (MPG) according to German VDE/EN/IEC standards, other technical specifications as well as possible provisions of law with respect to safety and health requirements.
	Mark of Conformity in the Russia, Kazakhstan, Armenia, Kyrgyzstan and Belarus Customs Union for imports of Machinery and Industrial Equipment
	The product complies with the requirements of the United Kingdom Water Supply (Water Fittings) Regulations/Scottish Water Byelaws. Applies to the stainless-steel version only.
	The Turkish Standards Institute (TSE) certified that this product complies with the relevant directives and standards.
ACS	ACS - Attestation de Conformité Sanitaire. The suitability of this product to come into contact with water destined for human consumption has been evaluated and approved by a laboratory accredited by the French Ministry of Health.

7. Performance curves and technical data

MAGNA1 25-40 (N) PN 10

1 x 230 V, 50/60 Hz

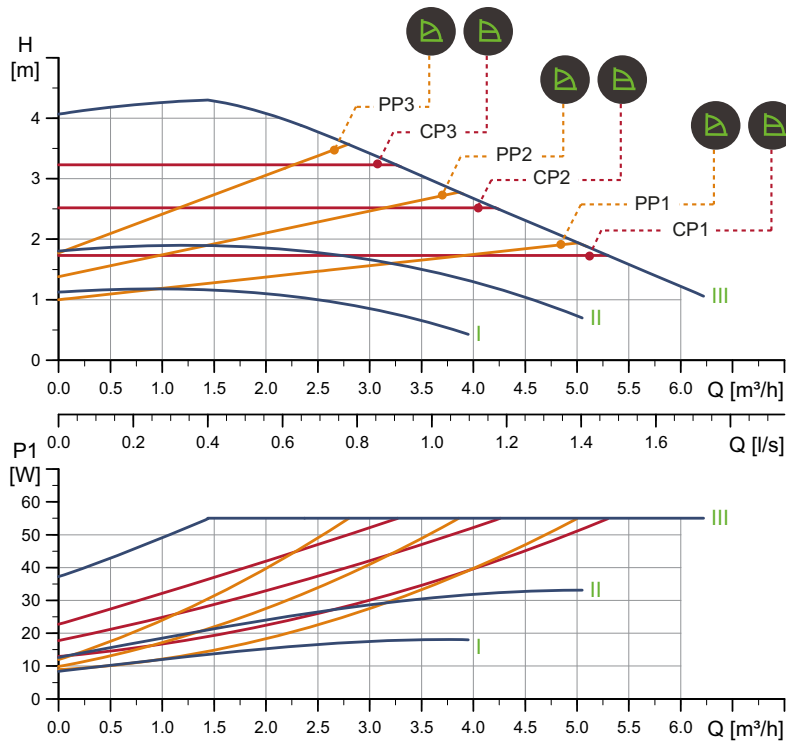

TM05 6316 4711

Speed	P1 [W]	$I_{1/1}$ [A]
Min.	9	0.09
Max.	56	0.45

The pump incorporates overload protection.

Net weight [kg]	Gross weight [kg]	Ship. vol. [m³]
4.4	5.4	0.012

Connections: See section [Pipe connection](#), page 110.
 System pressure: Max. 1.0 MPa (10 bar).
 Liquid temperature: -10 to 110 °C (TF 110).
 Also available with: Stainless-steel pump housing, type N.
 Specific EEI: 0.20.

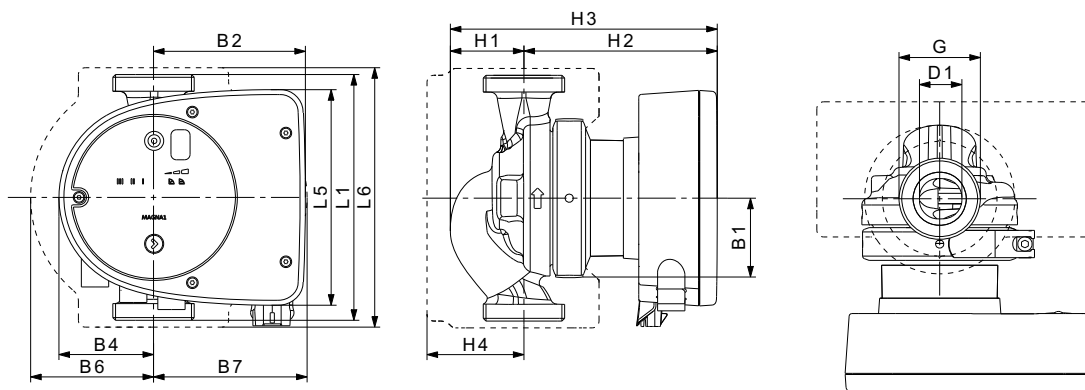

TM06 9948 3717

Pump type	Dimensions [mm]												(inch)	
	L1	L5	L6	B1	B2	B4	B6	B7	H1	H2	H3	H4	D1	G
MAGNA1 25-40 (N)	180	158	190	58	111	69	90	113	54	142	196	71	25	1 1/2

For product numbers, see page 115.

MAGNA1 25-60 (N) PN 10

1 x 230 V, 50/60 Hz

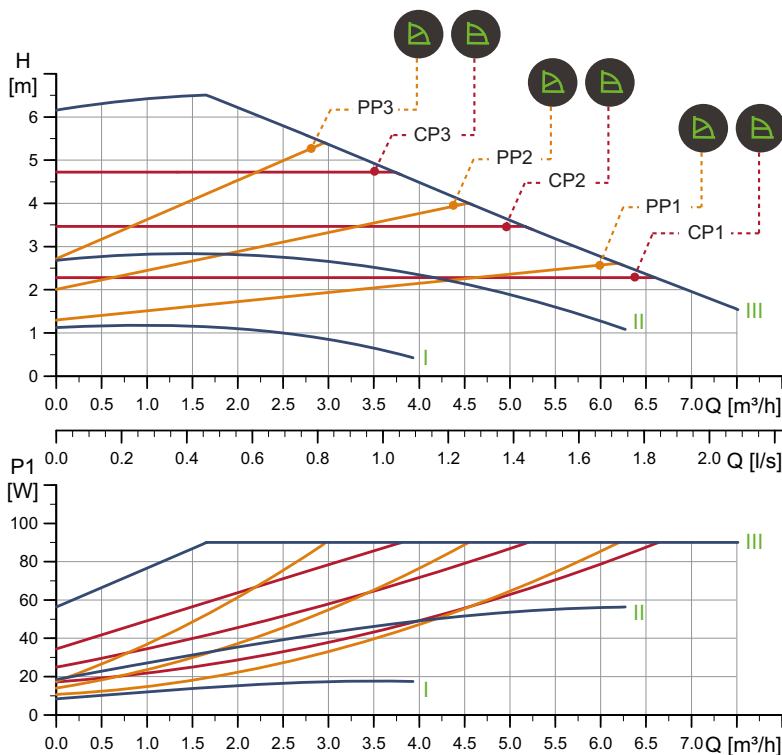

TM07 0562 0318

Speed	P1 [W]	I _{1/1} [A]
Min.	9	0.09
Max.	92	0.74

Connections: See section [Pipe connection](#), page 110.
 System pressure: Max. 1.0 MPa (10 bar).
 Liquid temperature: -10 to 110 °C (TF 110).
 Also available with: Stainless-steel pump housing, type N.
 Specific EEI: 0.20.

The pump incorporates overload protection.

Net weight [kg]	Gross weight [kg]	Ship. vol. [m³]
4.4	5.4	0.012

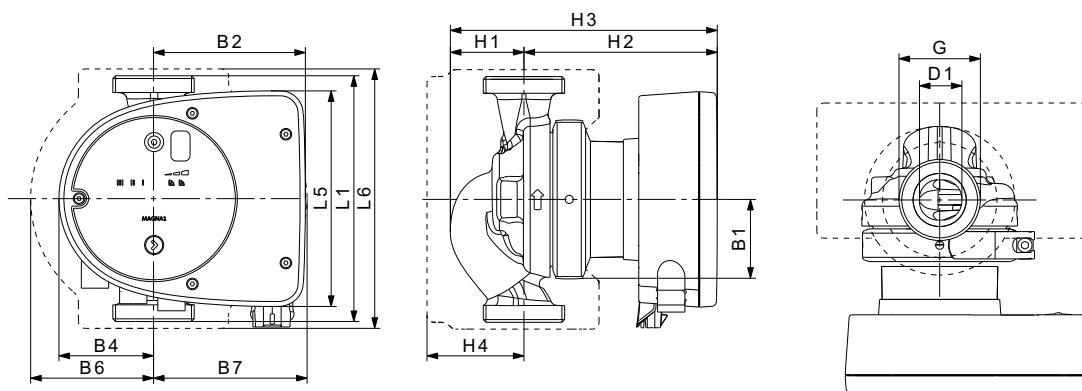

TM06 9948 3717

Pump type	Dimensions [mm]													(inch)
	L1	L5	L6	B1	B2	B4	B6	B7	H1	H2	H3	H4	D1	G
MAGNA1 25-60 (N)	180	158	190	58	111	69	90	113	54	142	196	71	25	1 1/2

For product numbers, see page 115.

MAGNA1 25-80 (N) PN 10

1 x 230 V, 50/60 Hz

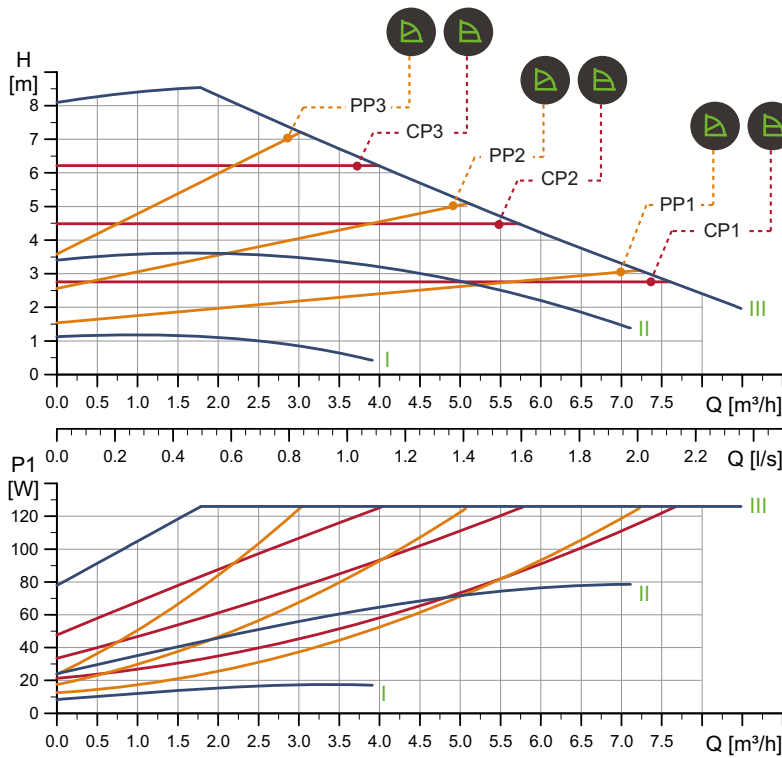

Speed	P1 [W]	I _{1/1} [A]
Min.	9	0.09
Max.	128	1.03

The pump incorporates overload protection.

Net weight [kg]	Gross weight [kg]	Ship. vol. [m³]
4.4	5.4	0.012

Connections: See section [Pipe connection](#), page 110.
 System pressure: Max. 1.0 MPa (10 bar).
 Liquid temperature: -10 to 110 °C (TF 110).
 Also available with: Stainless-steel pump housing, type N.
 Specific EEI: 0.20.

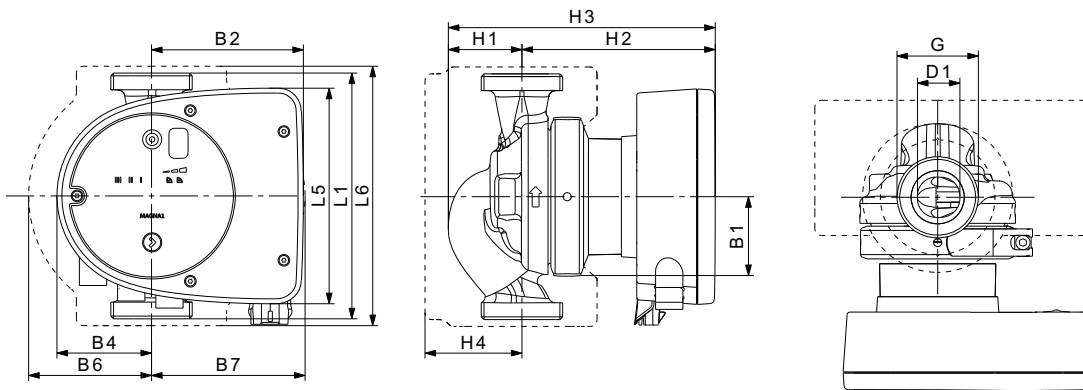

Pump type	Dimensions [mm]													(inch)	
	L1	L5	L6	B1	B2	B4	B6	B7	H1	H2	H3	H4	D1	G	
MAGNA1 25-80 (N)	180	158	190	58	111	69	90	113	54	142	196	71	25	1 1/2	

For product numbers, see page 115.

TM07 0563 0318

TM06 9948 3717

MAGNA1 25-100 (N) PN 10

1 x 230 V, 50/60 Hz

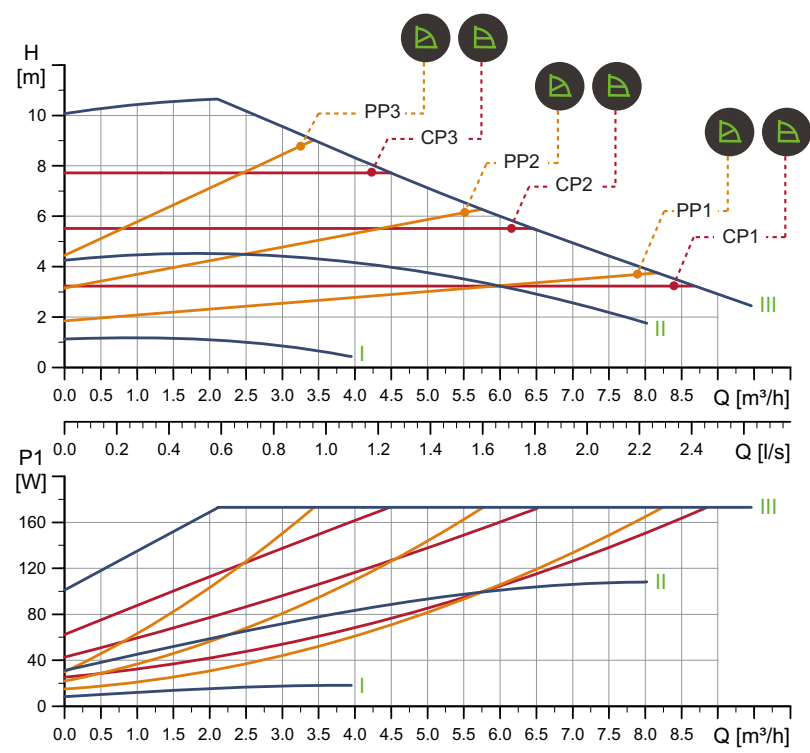

TM05 6322.4712

Speed	P1 [W]	I _{1/1} [A]
Min.	9	0.09
Max.	176	1.42

Connections: See section [Pipe connection](#), page 110.
 System pressure: Max. 1.0 MPa (10 bar).
 Liquid temperature: -10 to 110 °C (TF 110).
 Also available with: Stainless-steel pump housing, type N.
 Specific EEI: 0.20.

The pump incorporates overload protection.

Net weight [kg]	Gross weight [kg]	Ship. vol. [m³]
4.4	5.4	0.012

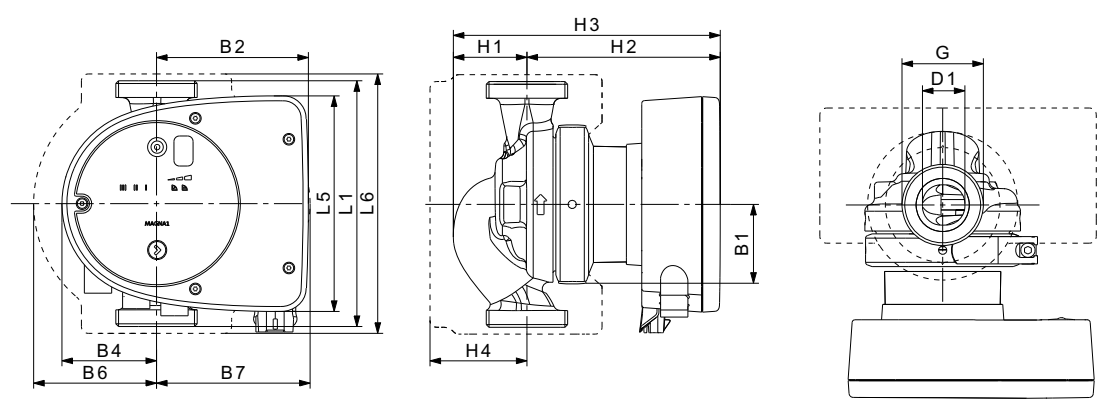

TM06 9948 3717

Pump type	Dimensions [mm]													(inch)
	L1	L5	L6	B1	B2	B4	B6	B7	H1	H2	H3	H4	D1	G
MAGNA1 25-100 (N)	180	158	190	58	111	69	90	113	54	142	196	71	25	1 1/2

For product numbers, see page 115.

MAGNA1 25-120 (N) PN 10

1 x 230 V, 50/60 Hz

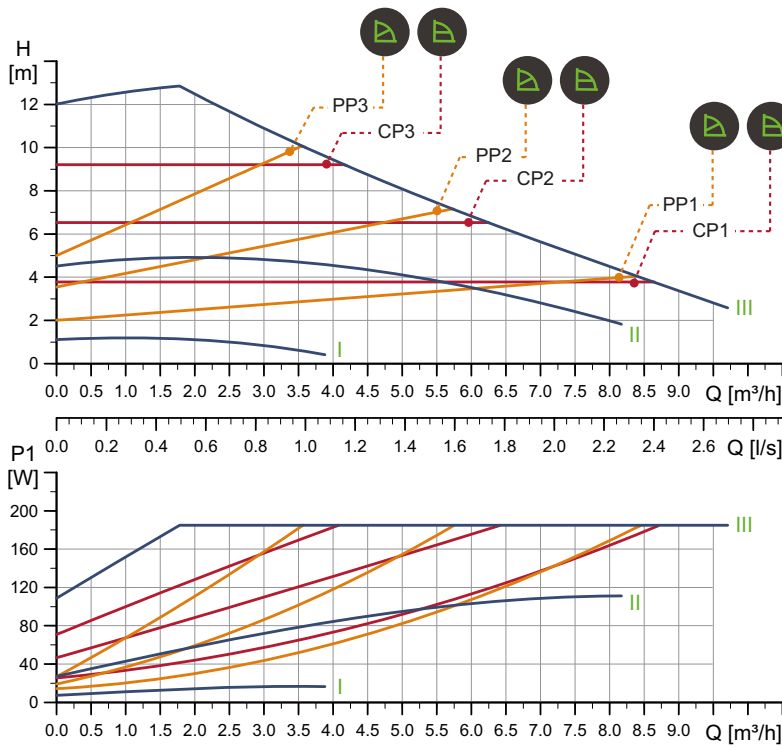

TM05 6324 4712

Speed	P1 [W]	I _{1/1} [A]
Min.	8	0.08
Max.	188	1.51

Connections: See section [Pipe connection](#), page 110.
 System pressure: Max. 1.0 MPa (10 bar).
 Liquid temperature: -10 to 110 °C (TF 110).
 Also available with: Stainless-steel pump housing, type N.
 Specific EEI: 0.20.

The pump incorporates overload protection.

Net weight [kg]	Gross weight [kg]	Ship. vol. [m³]
4.4	5.4	0.012

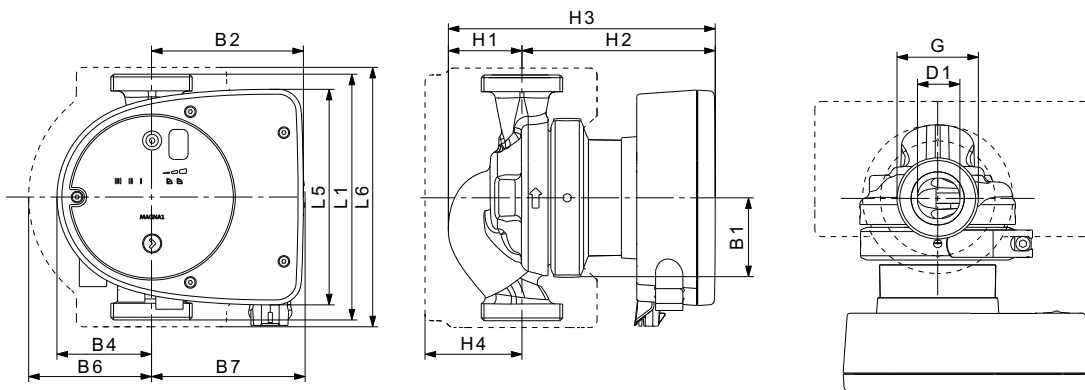

TM06 9948 3717

Pump type	Dimensions [mm]													(inch)	
	L1	L5	L6	B1	B2	B4	B6	B7	H1	H2	H3	H4	D1	G	
MAGNA1 25-120 (N)	180	158	190	58	111	69	90	113	54	142	196	71	25	1 1/2	

For product numbers, see page 115.

MAGNA1 32-40 (N) PN 10

1 x 230 V, 50/60 Hz

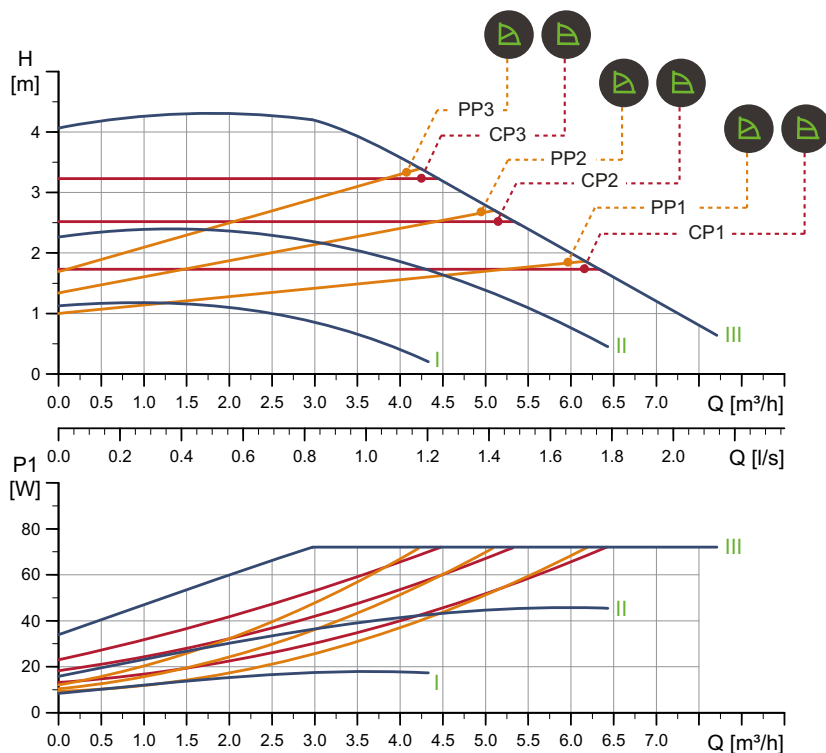

TM05 6325 4712

Speed	P1 [W]	I _{1/1} [A]
Min.	9	0.09
Max.	73	0.59

The pump incorporates overload protection.

Connections: See section [Pipe connection](#), page 110.
 System pressure: Max. 1.0 MPa (10 bar).
 Liquid temperature: -10 to 110 °C (TF 110).
 Also available with: Stainless-steel pump housing, type N.
 Specific EEI: 0.20.

Net weight [kg]	Gross weight [kg]	Ship. vol. [m ³]
4.4	5.4	0.012

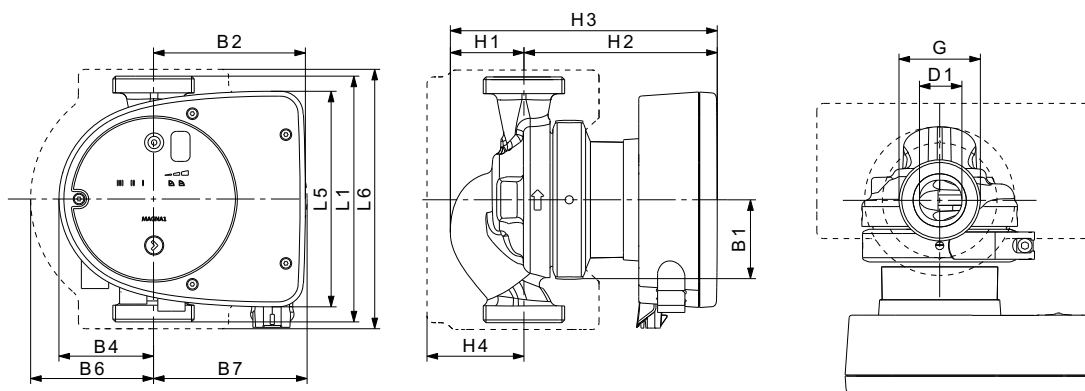

TM06 9948 3717

Pump type	Dimensions [mm]													(inch)	
	L1	L5	L6	B1	B2	B4	B6	B7	H1	H2	H3	H4	D1	G	
MAGNA1 32-40 (N)	180	158	190	58	111	69	90	113	54	142	196	71	32	2	

For product numbers, see page 115.

MAGNA1 D 32-40 PN 10

1 x 230 V, 50/60 Hz

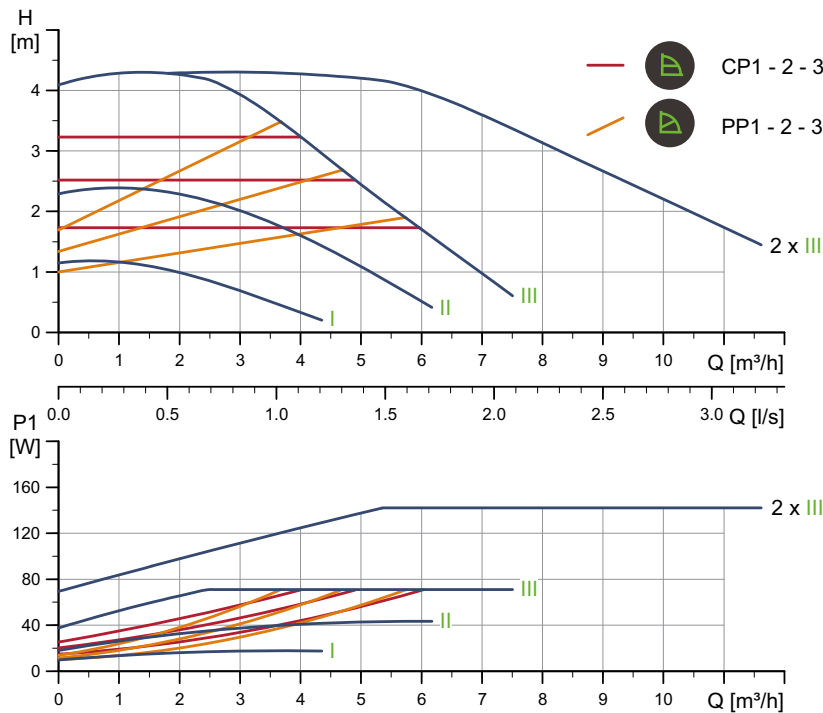

Speed	P1 [W]	I _{1/1} [A]
Min.	9	0.09
Max.	73	0.59

Connections: See section [Pipe connection](#), page 110.
 System pressure: Max. 1.0 MPa (10 bar).
 Liquid temperature: -10 to 110 °C (TF 110).
 Specific EEI: 0.23.

The pump incorporates overload protection.

Net weight [kg]	Gross weight [kg]	Ship. vol. [m³]
12.4	13.4	0.045

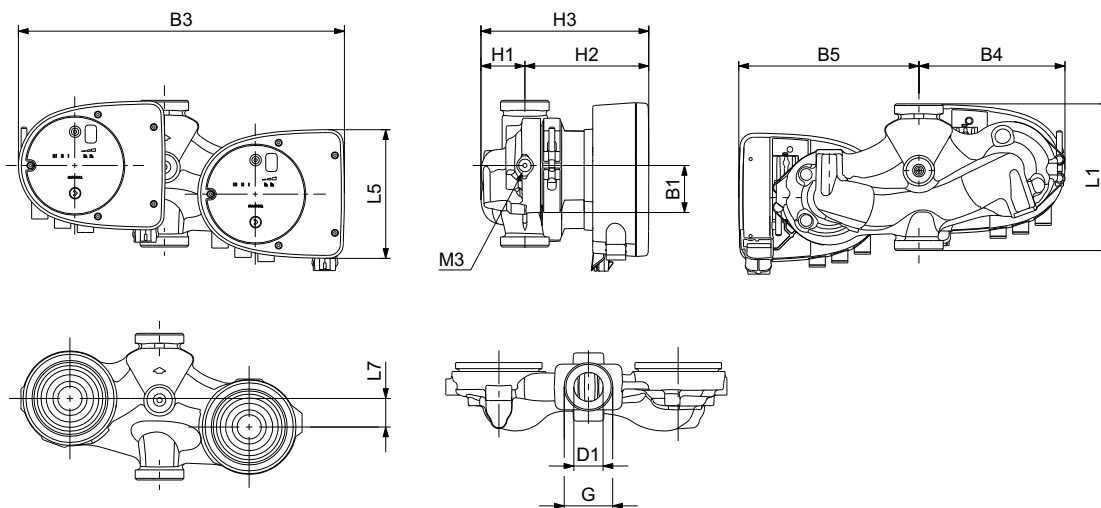

Pump type	Dimensions [mm]											(inch)		
	L1	L5	L7	B1	B3	B4	B5	H1	H2	H3	D1	G	M3	
MAGNA1 D 32-40	180	158	35	58	400	179	221	54	142	196	32	2	1/4	

For product numbers, see page 115.

TM05 6363 4712

TM07 0068 4117

MAGNA1 32-60 (N) PN 10

1 x 230 V, 50/60 Hz

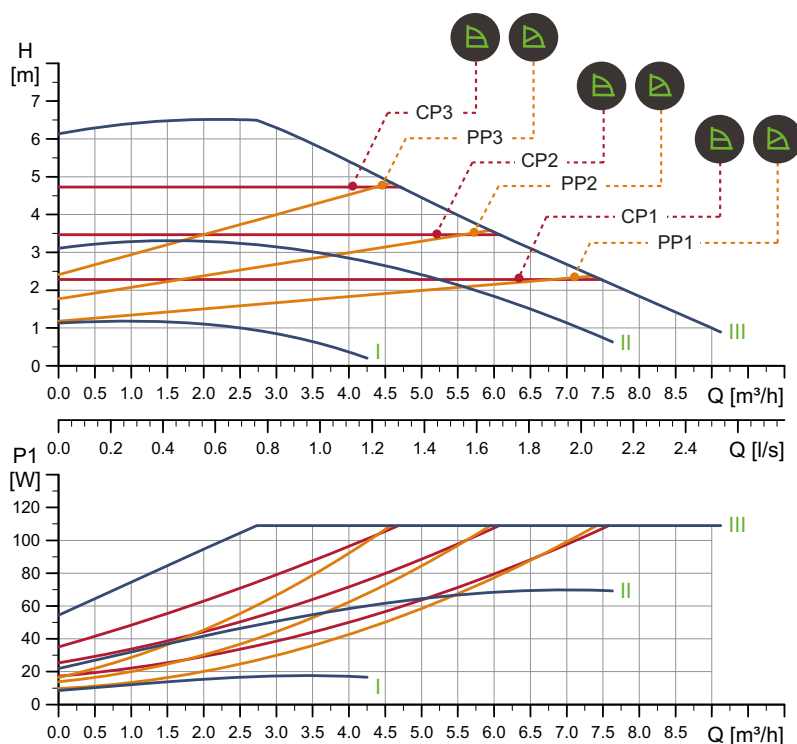

TM05 6327 4712

Speed	P1 [W]	$I_{1/1}$ [A]
Min.	9	0.09
Max.	111	0.9

The pump incorporates overload protection.

Net weight [kg]	Gross weight [kg]	Ship. vol. [m³]
4.4	5.4	0.012

Connections: See section [Pipe connection](#), page 110.
 System pressure: Max. 1.0 MPa (10 bar).
 Liquid temperature: -10 to 110 °C (TF 110).
 Also available with: Stainless-steel pump housing, type N.
 Specific EEI: 0.20.

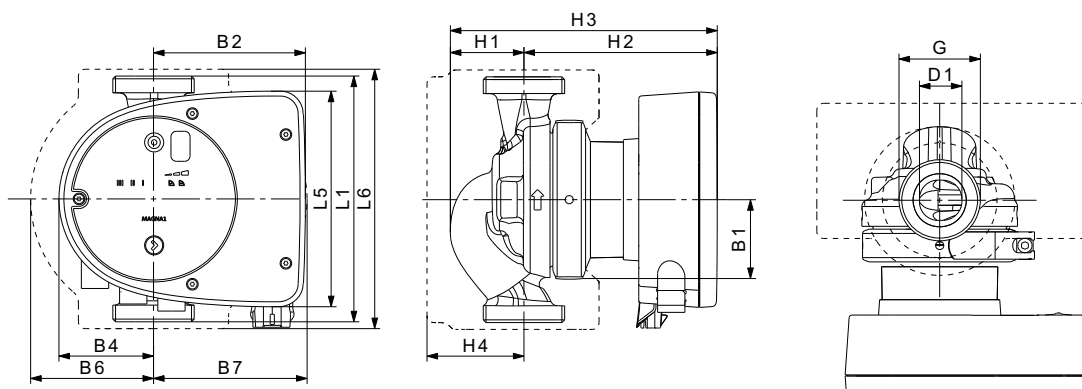

TM06 9948 3717

Pump type	Dimensions [mm]												(inch)	
	L1	L5	L6	B1	B2	B4	B6	B7	H1	H2	H3	H4	D1	G
MAGNA1 32-60 (N)	180	158	190	58	111	69	90	113	54	142	196	71	32	2

For product numbers, see page 115.

MAGNA1 D 32-60 PN 10

1 x 230 V, 50/60 Hz

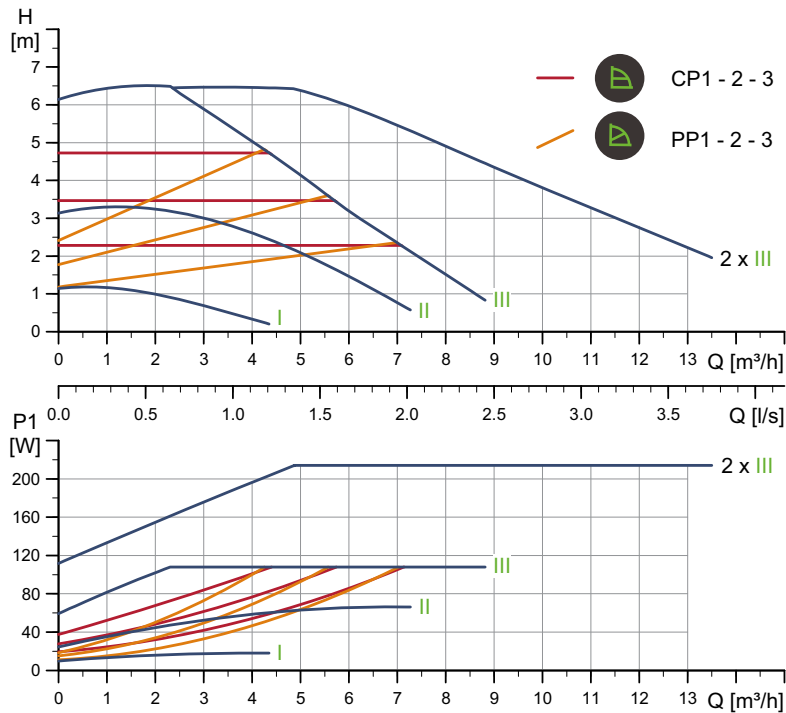

TM05 6365 4712

Speed	P1 [W]	$I_{1/1}$ [A]
Min.	9	0.09
Max.	111	0.9

Connections: See section [Pipe connection](#), page 110.
 System pressure: Max. 1.0 MPa (10 bar).
 Liquid temperature: -10 to 110 °C (TF 110).
 Specific EEI: 0.23.

The pump incorporates overload protection.

Net weight [kg]	Gross weight [kg]	Ship. vol. [m ³]
12.4	13.4	0.045

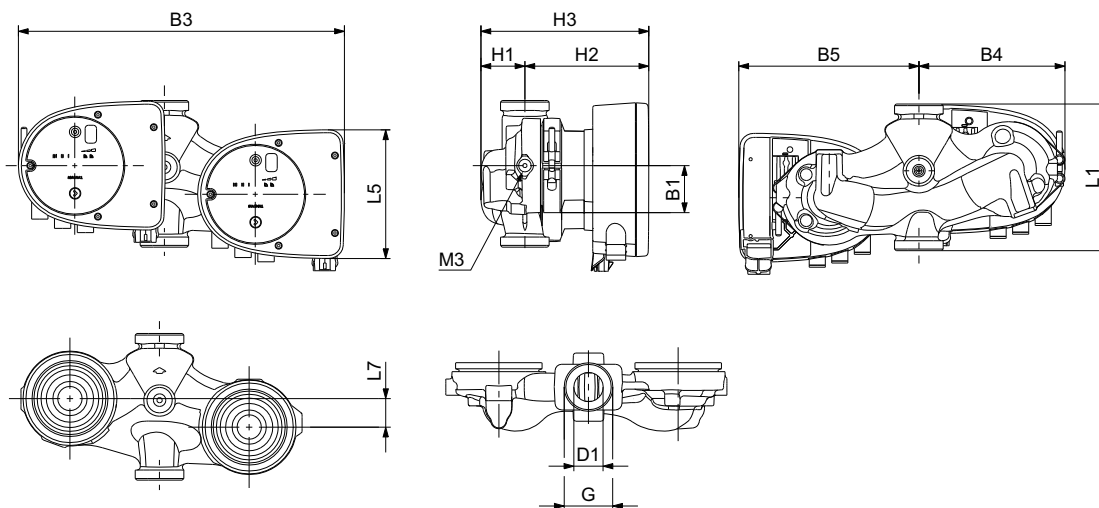

TM07 0068 4117

Pump type	Dimensions [mm]											(inch)	
	L1	L5	L7	B1	B3	B4	B5	H1	H2	H3	D1	G	M3
MAGNA1 D 32-60	180	158	35	58	400	179	221	54	142	196	32	2	1/4

For product numbers, see page 115.

MAGNA1 32-80 (N) PN 10

1 x 230 V, 50/60 Hz

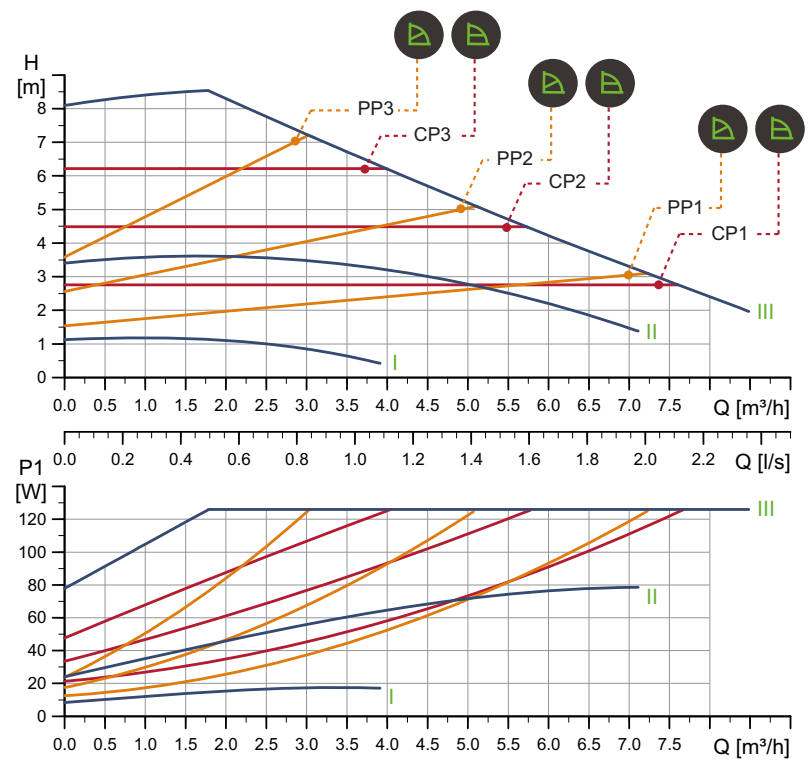

TM07 0564 0318

Speed	P1 [W]	I _{1/1} [A]
Min.	9	0.09
Max.	151	1.22

The pump incorporates overload protection.

Connections: See section [Pipe connection](#), page 110.
 System pressure: Max. 1.0 MPa (10 bar).
 Liquid temperature: -10 to 110 °C (TF 110).
 Also available with: Stainless-steel pump housing, type N.
 Specific EEI: 0.20.

Net weight [kg]	Gross weight [kg]	Ship. vol. [m³]
4.4	5.4	0.012

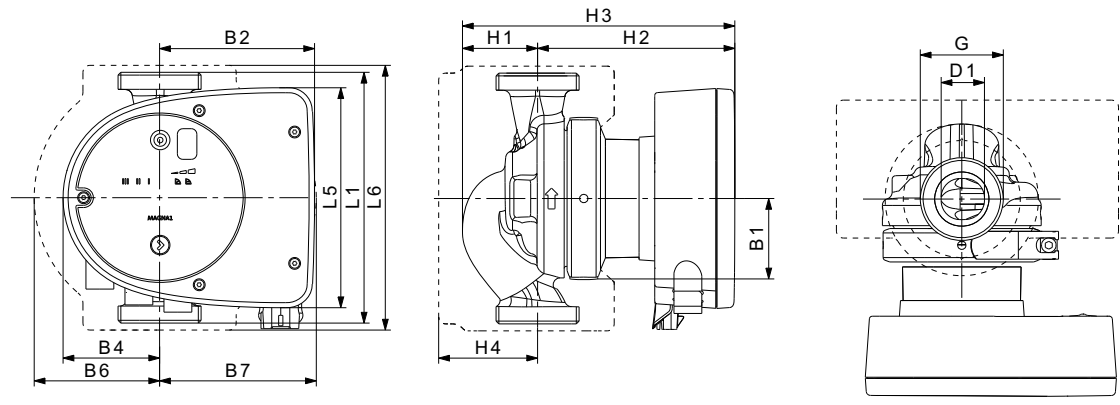

TM06 9948 3717

Pump type	Dimensions [mm]													(inch)	
	L1	L5	L6	B1	B2	B4	B6	B7	H1	H2	H3	H4	D1	G	
MAGNA1 32-80 (N)	180	158	190	58	111	69	90	113	54	142	196	71	32	2	

For product numbers, see page 115.

MAGNA1 D 32-80 PN 10

1 x 230 V, 50/60 Hz

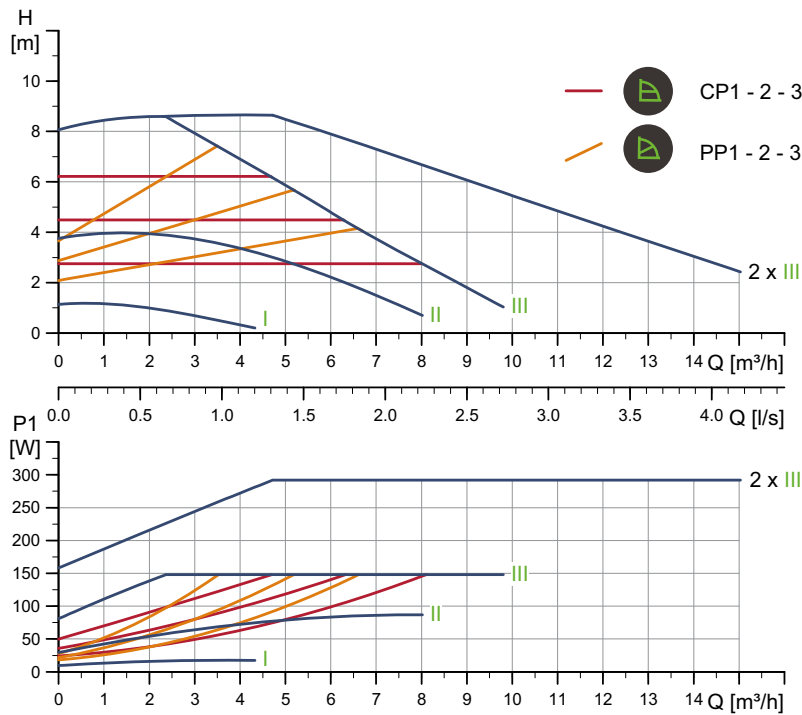

Speed	P1 [W]	I _{1/1} [A]
Min.	9	0.09
Max.	151	1.22

Connections: See section [Pipe connection](#), page 110.
 System pressure: Max. 1.0 MPa (10 bar).
 Liquid temperature: -10 to 110 °C (TF 110).
 Specific EEI: 0.23.

The pump incorporates overload protection.

Net weight [kg]	Gross weight [kg]	Ship. vol. [m³]
12.4	13.4	0.045

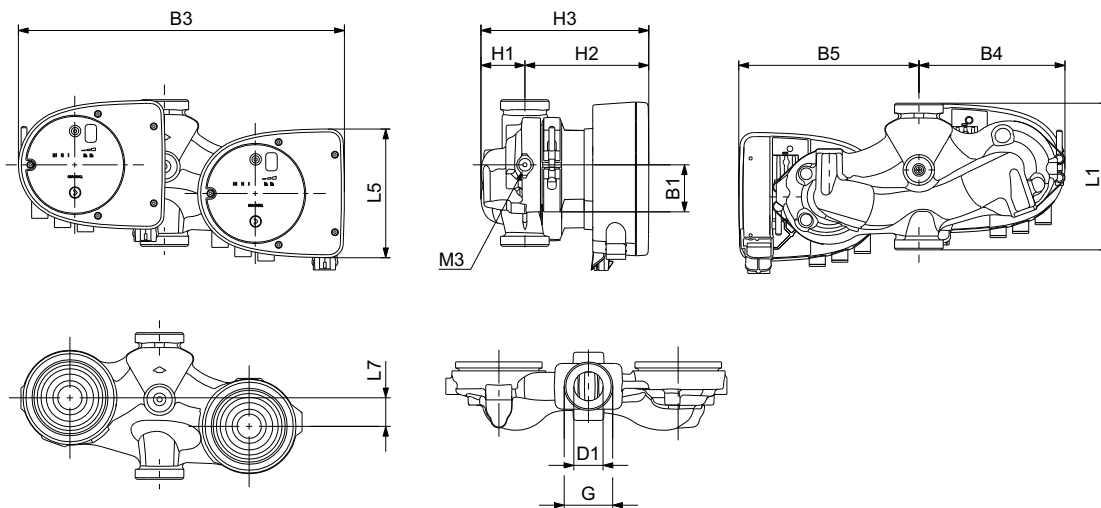

Pump type	Dimensions [mm]											(inch)		
	L1	L5	L7	B1	B3	B4	B5	H1	H2	H3	D1	G	M3	
MAGNA1 D 32-80	180	158	35	58	400	179	221	54	142	196	32	2	1/4	

For product numbers, see page 115.

TM05 6367 4712

TM07 0068 4117

MAGNA1 32-100 (N) PN 10

1 x 230 V, 50/60 Hz

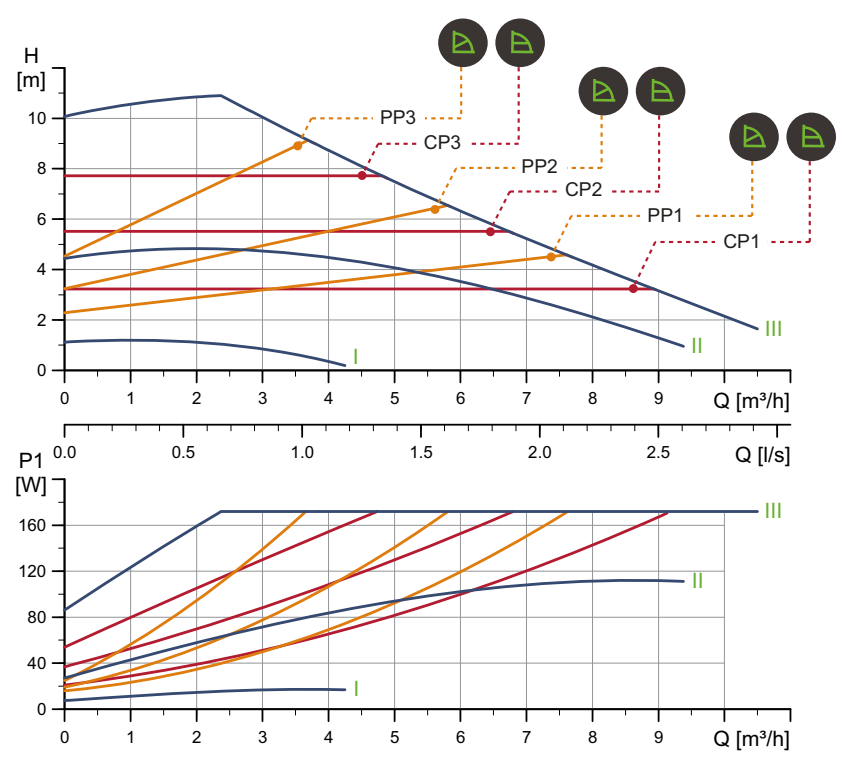

Speed	P1 [W]	I _{1/1} [A]
Min.	8	0.08
Max.	175	1.41

The pump incorporates overload protection.

Connections: See section [Pipe connection](#), page 110.
 System pressure: Max. 1.0 MPa (10 bar).
 Liquid temperature: -10 to 110 °C (TF 110).
 Also available with: Stainless-steel pump housing, type N.
 Specific EEI: 0.20.

Net weight [kg]	Gross weight [kg]	Ship. vol. [m ³]
4.4	5.4	0.012

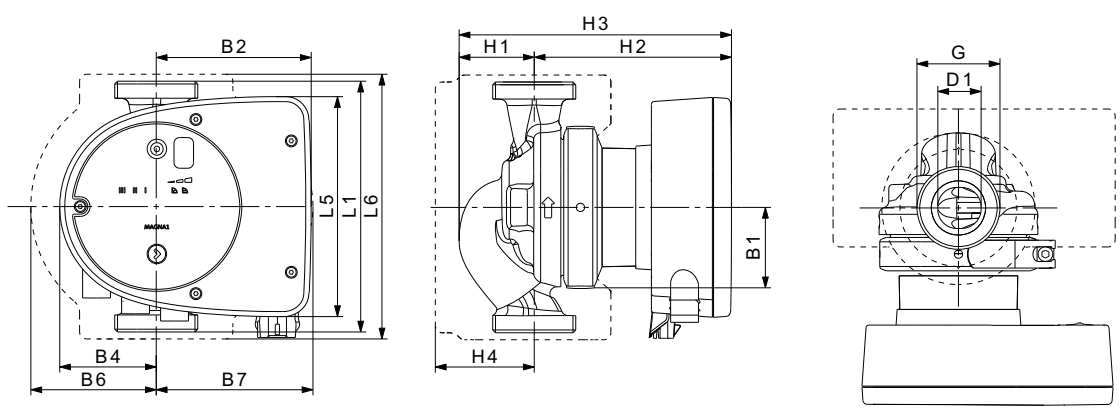

Pump type	Dimensions [mm]												(inch)	
	L1	L5	L6	B1	B2	B4	B6	B7	H1	H2	H3	H4	D1	G
MAGNA1 32-100 (N)	180	158	190	58	111	69	90	113	54	142	196	71	32	2

For product numbers, see page 115.

TM05 6331 4712

TM06 9948 3717

MAGNA1 D 32-100 PN 10

1 x 230 V, 50/60 Hz

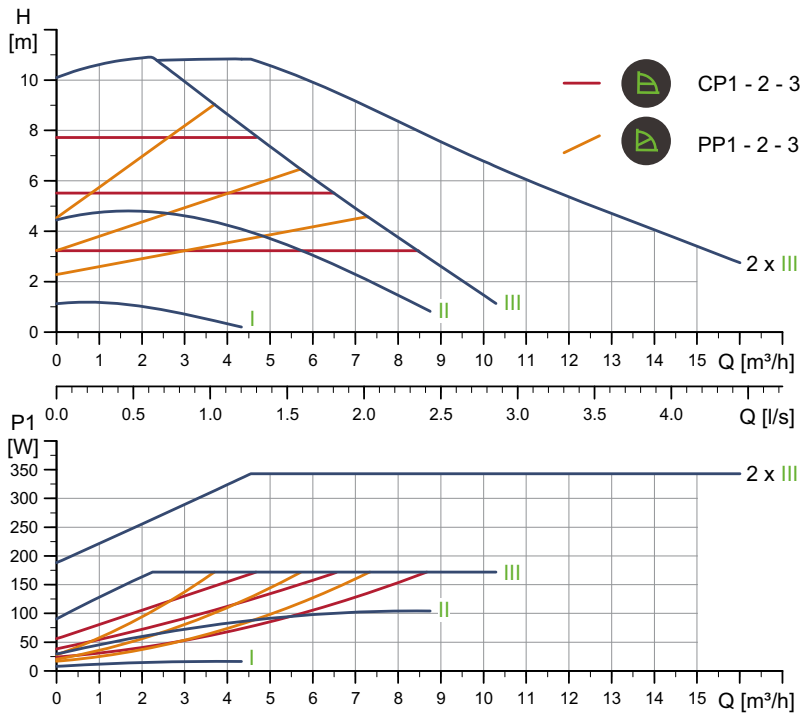

Speed	P1 [W]	I _{1/1} [A]
Min.	8	0.08
Max.	175	1.41

Connections: See section [Pipe connection](#), page 110.
 System pressure: Max. 1.0 MPa (10 bar).
 Liquid temperature: -10 to 110 °C (TF 110).
 Specific EEI: 0.22.

The pump incorporates overload protection.

Net weight [kg]	Gross weight [kg]	Ship. vol. [m³]
12.4	13.4	0.045

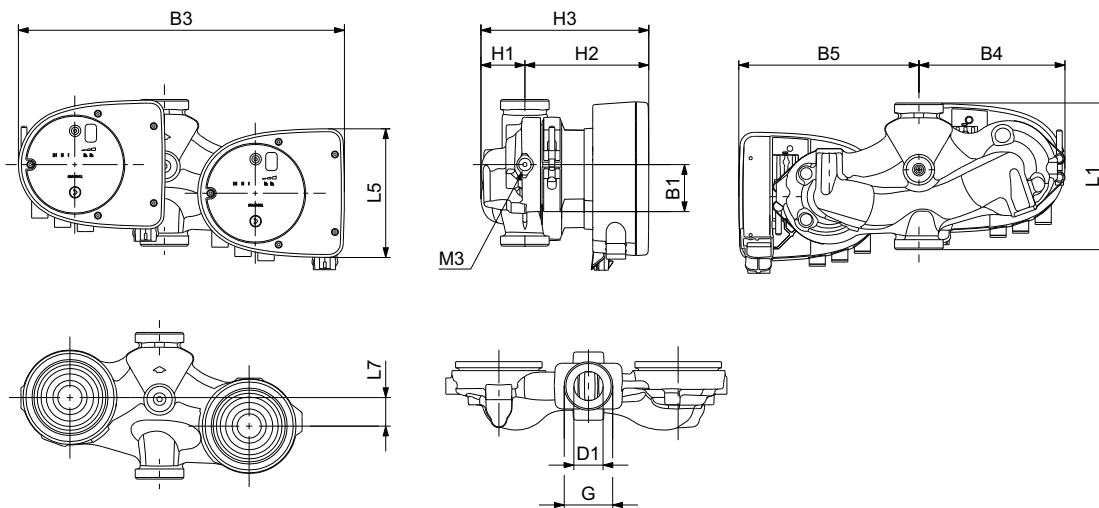

Pump type	Dimensions [mm]											(inch)		
	L1	L5	L7	B1	B3	B4	B5	H1	H2	H3	D1	G	M3	
MAGNA1 D 32-100	180	158	35	58	400	179	221	54	142	196	32	2	1/4	

For product numbers, see page 115.

TM05 6369 4712

TM07 0068 4117

MAGNA1 32-120 (N) PN 10

1 x 230 V, 50/60 Hz

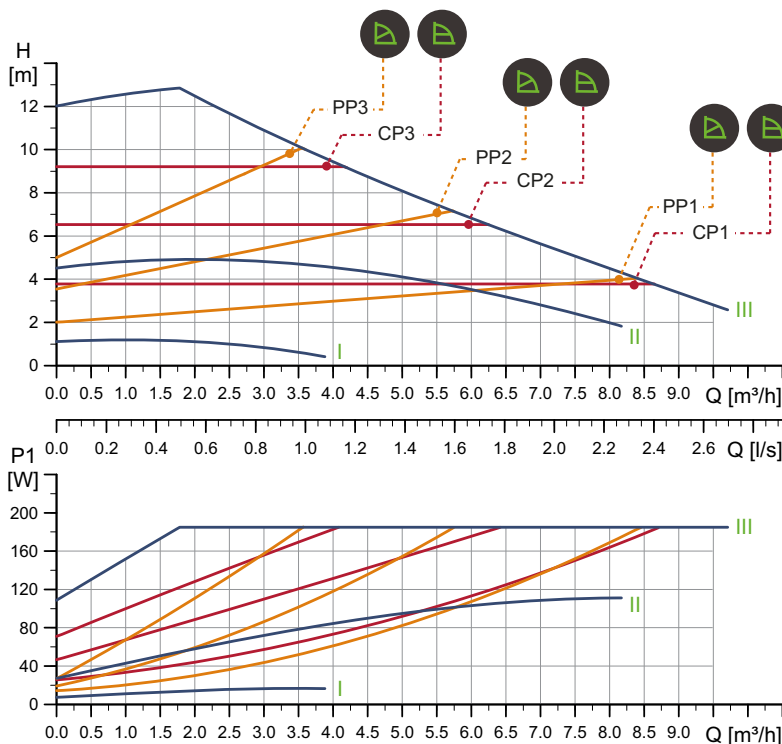

TM05 6324 4712

Speed	P1 [W]	I _{1/1} [A]
Min.	8	0.08
Max.	188	1.51

The pump incorporates overload protection.

Connections: See section [Pipe connection](#), page 110.
 System pressure: Max. 1.0 MPa (10 bar).
 Liquid temperature: -10 to 110 °C (TF 110).
 Also available with: Stainless-steel pump housing, type N.
 Specific EEI: 0.20.

Net weight [kg]	Gross weight [kg]	Ship. vol. [m³]
4.4	5.4	0.012

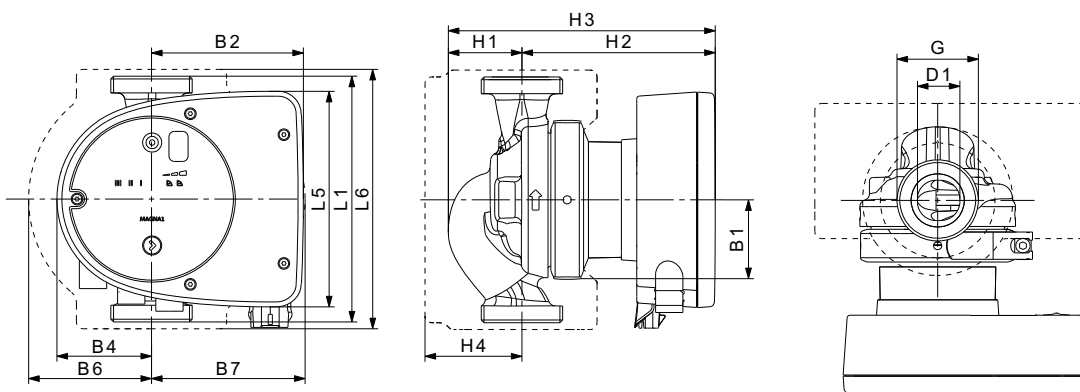

TM06 9948 3717

Pump type	Dimensions [mm]													(inch)	
	L1	L5	L6	B1	B2	B4	B6	B7	H1	H2	H3	H4	D1	G	
MAGNA1 32-120 (N)	180	158	190	58	111	69	90	113	54	142	196	71	32	2	

For product numbers, see page 115.

MAGNA1 32-40 F (N) PN 10

1 x 230 V, 50/60 Hz

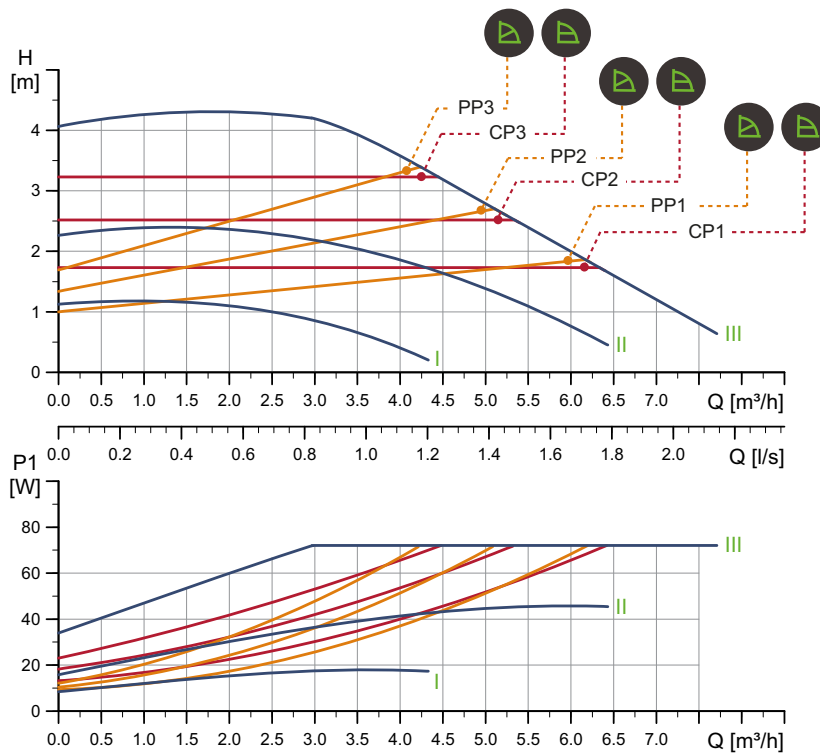

Speed	P1 [W]	I _{1/1} [A]
Min.	9	0.09
Max.	73	0.59

The pump incorporates overload protection.

Connections: See section [Pipe connection](#), page 110.
 System pressure: Max. 1.0 MPa (10 bar).
 Liquid temperature: -10 to 110 °C (TF 110).
 Also available with: Stainless-steel pump housing, type N.
 Specific EEI: 0.20.

Net weight [kg]	Gross weight [kg]	Ship. vol. [m³]
7.4	8.4	0.016

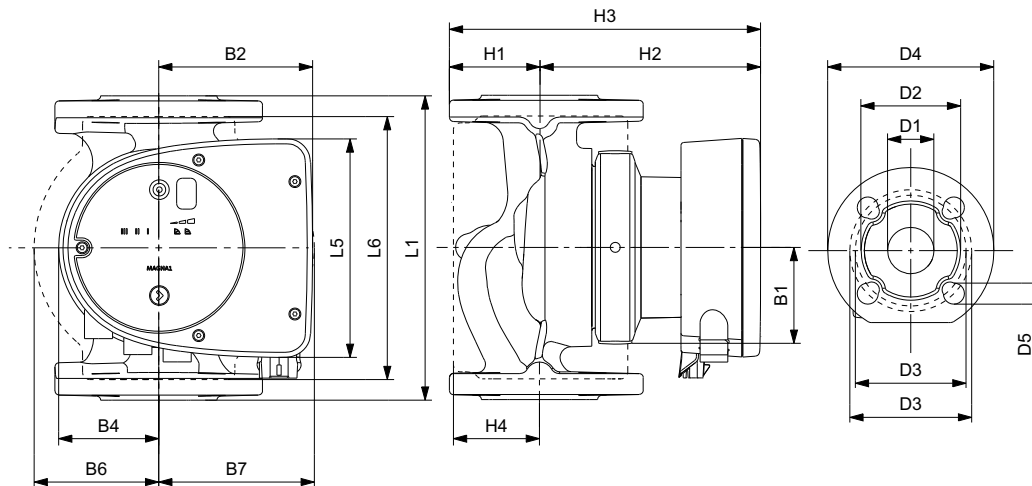

Pump type	Dimensions [mm]																
	L1	L5	L6	B1	B2	B4	B6	B7	H1	H2	H3	H4	D1	D2	D3	D4	D5
MAGNA1 32-40 F (N)	220	158	220	58	111	69	100	110	65	142	207	82	32	76	90/100	140	14/19

For product numbers, see page 115.

TM05 6325 4712

TM07 0067 4117

MAGNA1 D 32-40 F PN 10

1 x 230 V, 50/60 Hz

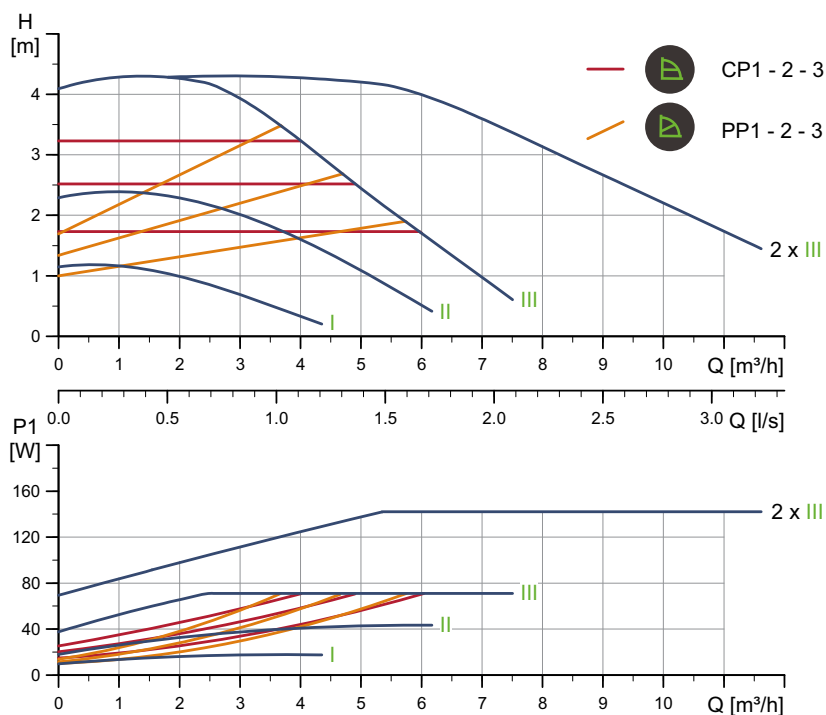

TM05 6363 4712

Speed	P1 [W]	I _{1/1} [A]
Min.	9	0.09
Max.	73	0.59

Connections: See section [Pipe connection](#), page 110.
 System pressure: Max. 1.0 MPa (10 bar).
 Liquid temperature: -10 to 110 °C (TF 110).
 Specific EEI: 0.23.

The pump incorporates overload protection.

Net weight [kg]	Gross weight [kg]	Ship. vol. [m³]
14.7	15.7	0.045

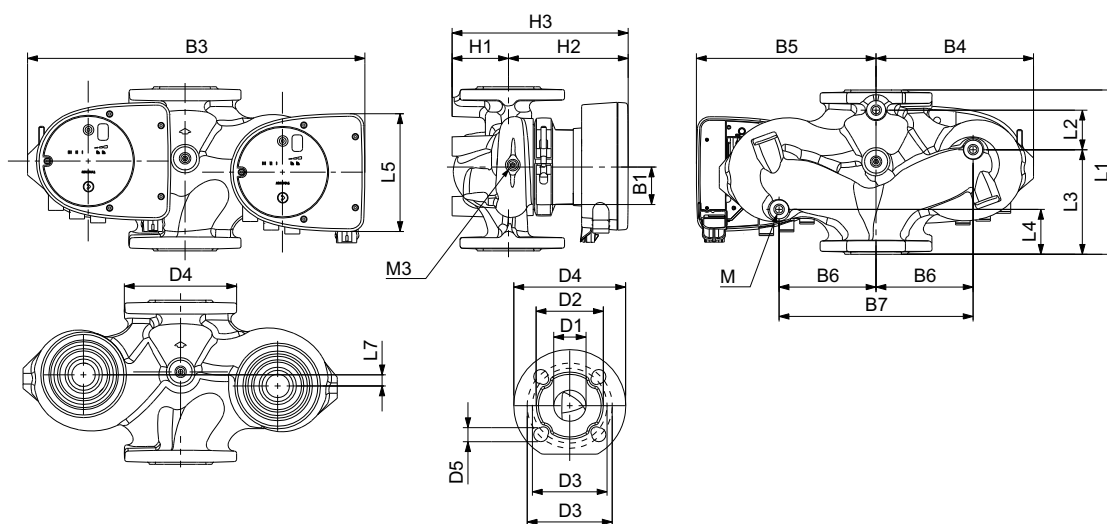

TM07 0069 4117

Pump type	Dimensions [mm]																			Rp		
	L1	L2	L3	L4	L5	L7	B1	B3	B4	B5	B6	B7	H1	H2	H3	D1	D2	D3	D4		D5	M
MAGNA1 D 32-40 F	220	73	120	85	158	35	58	400	179	221	130	260	69	142	211	32	76	90/100	140	14/19	12	1/4

For product numbers, see page 115.

MAGNA1 32-60 F (N) PN 10

1 x 230 V, 50/60 Hz

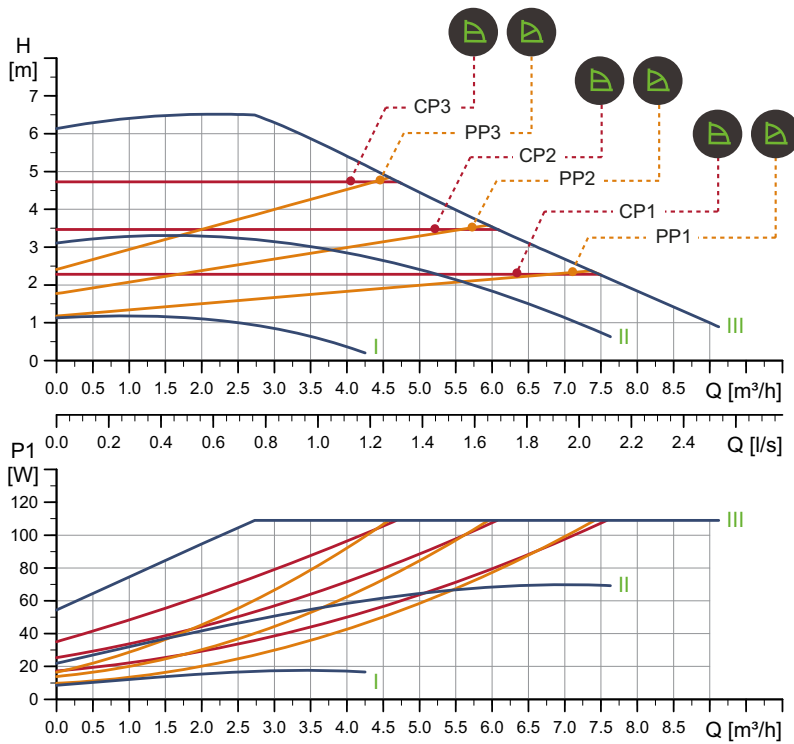

Speed	P1 [W]	I _{1/1} [A]
Min.	9	0.09
Max.	111	0.90

The pump incorporates overload protection.

Connections: See section [Pipe connection](#), page 110.
 System pressure: Max. 1.0 MPa (10 bar).
 Liquid temperature: -10 to 110 °C (TF 110).
 Also available with: Stainless-steel pump housing, type N.
 Specific EEI: 0.20.

Net weight [kg]	Gross weight [kg]	Ship. vol. [m³]
7.4	8.4	0.016

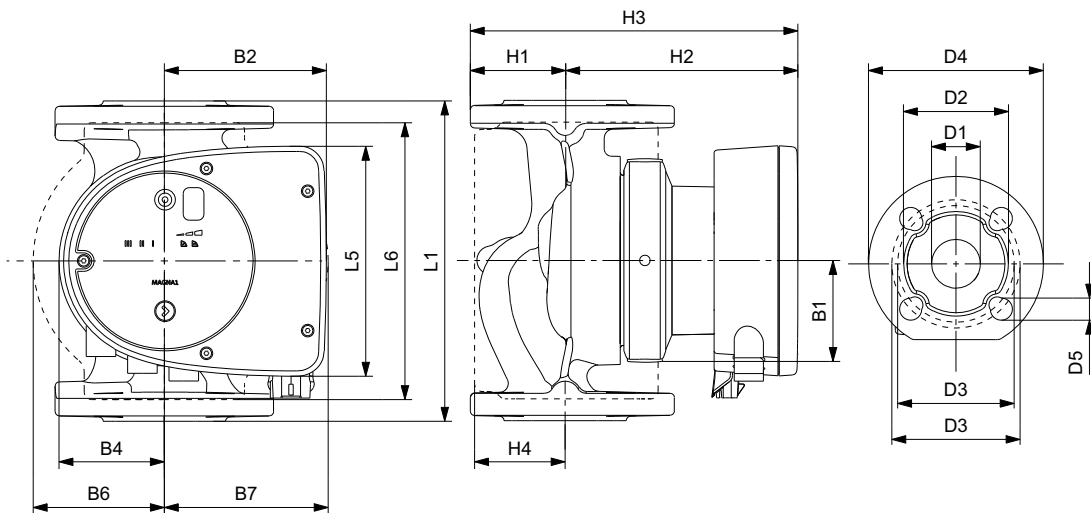

Pump type	Dimensions [mm]																
	L1	L5	L6	B1	B2	B4	B6	B7	H1	H2	H3	H4	D1	D2	D3	D4	D5
MAGNA1 32-60 F (N)	220	158	220	58	111	69	100	110	65	142	207	82	32	76	90/100	140	14/19

For product numbers, see page 115.

TM05 6327 4712

TM07 0067 4117

MAGNA1 D 32-60 F PN 10

1 x 230 V, 50/60 Hz

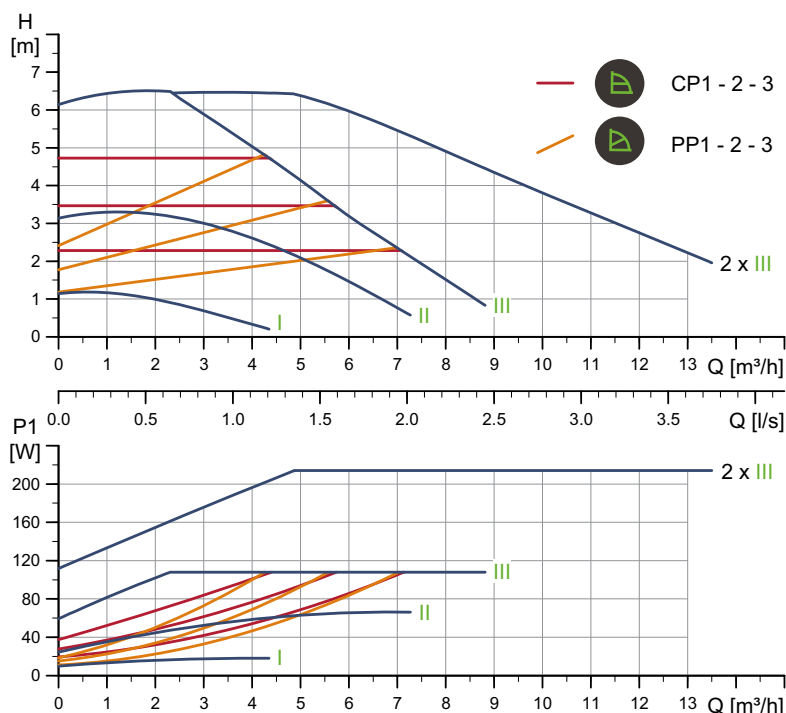

TM05 6365 4712

Speed	P1 [W]	I _{1/1} [A]
Min.	9	0.09
Max.	111	0.90

Connections: See section [Pipe connection](#), page 110.
 System pressure: Max. 1.0 MPa (10 bar).
 Liquid temperature: -10 to 110 °C (TF 110).
 Specific EEI: 0.23.

The pump incorporates overload protection.

Net weight [kg]	Gross weight [kg]	Ship. vol. [m³]
14.7	15.7	0.045

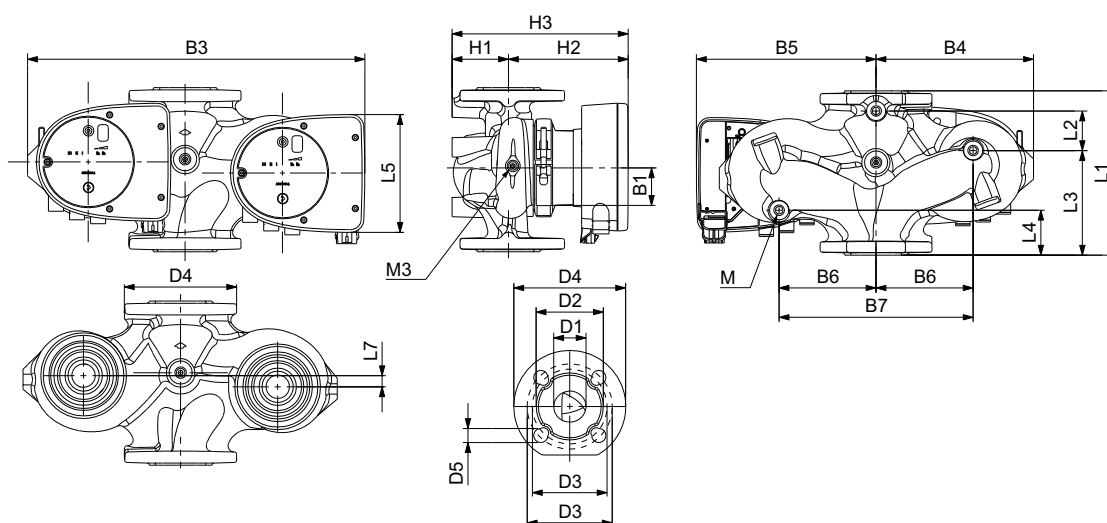

TM07 0069 4117

Pump type	Dimensions [mm]																			Rp		
	L1	L2	L3	L4	L5	L7	B1	B3	B4	B5	B6	B7	H1	H2	H3	D1	D2	D3	D4		D5	M
MAGNA1 D 32-60 F	220	73	120	85	158	35	58	400	179	221	130	260	69	142	211	32	76	90/100	140	14/19	12	1/4

For product numbers, see page 115.

MAGNA1 32-80 F (N) PN 10

1 x 230 V, 50/60 Hz

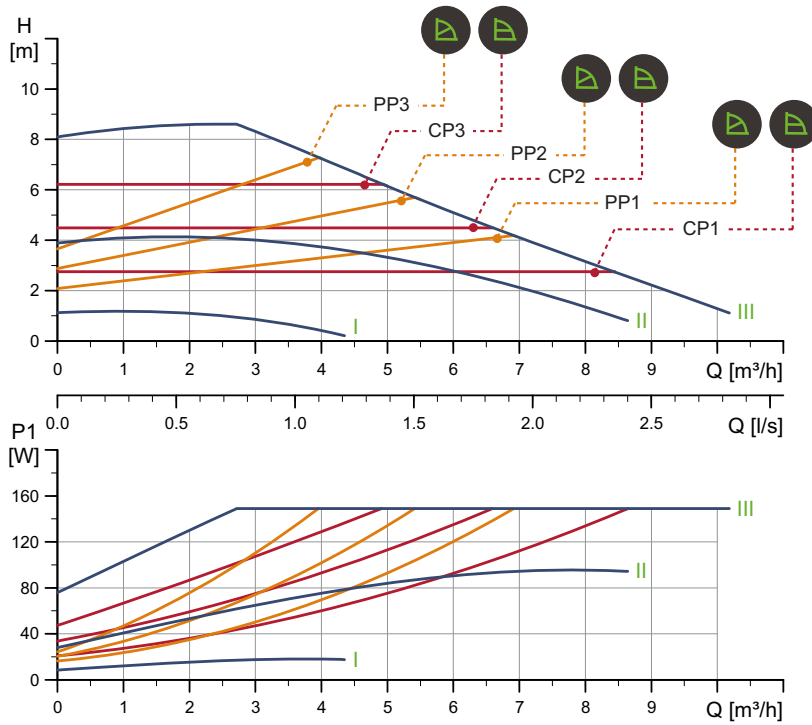

Speed	P1 [W]	I _{1/1} [A]
Min.	9	0.09
Max.	151	1.22

The pump incorporates overload protection.

Connections: See section [Pipe connection](#), page 110.
 System pressure: Max. 1.0 MPa (10 bar).
 Liquid temperature: -10 to 110 °C (TF 110).
 Also available with: Stainless-steel pump housing, type N.
 Specific EEI: 0.20.

Net weight [kg]	Gross weight [kg]	Ship. vol. [m ³]
7.4	8.4	0.016

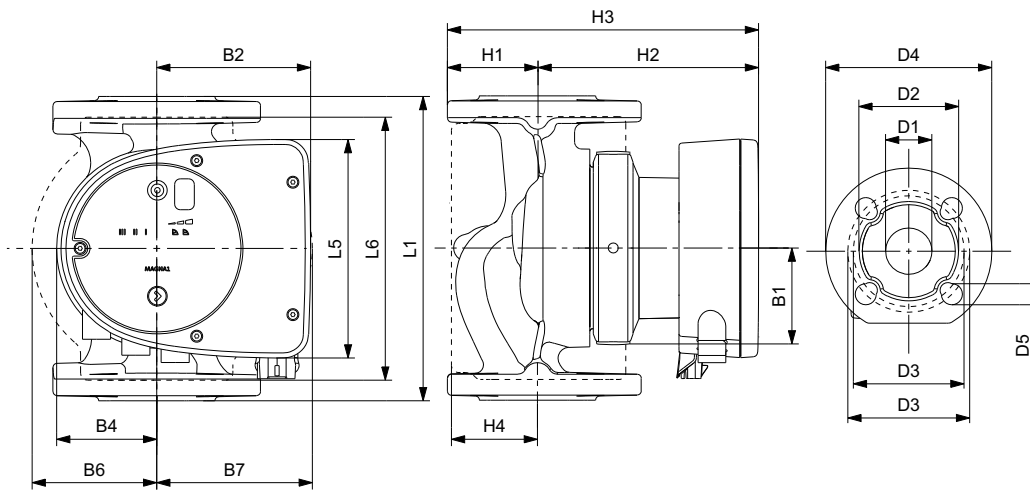

Pump type	Dimensions [mm]																
	L1	L5	L6	B1	B2	B4	B6	B7	H1	H2	H3	H4	D1	D2	D3	D4	D5
MAGNA1 32-80 F (N)	220	158	220	58	111	69	100	110	65	142	207	82	32	76	90/100	140	14/19

For product numbers, see page 115.

TM07 0564 0318

TM07 0067 4117

MAGNA1 D 32-80 F PN 10

1 x 230 V, 50/60 Hz

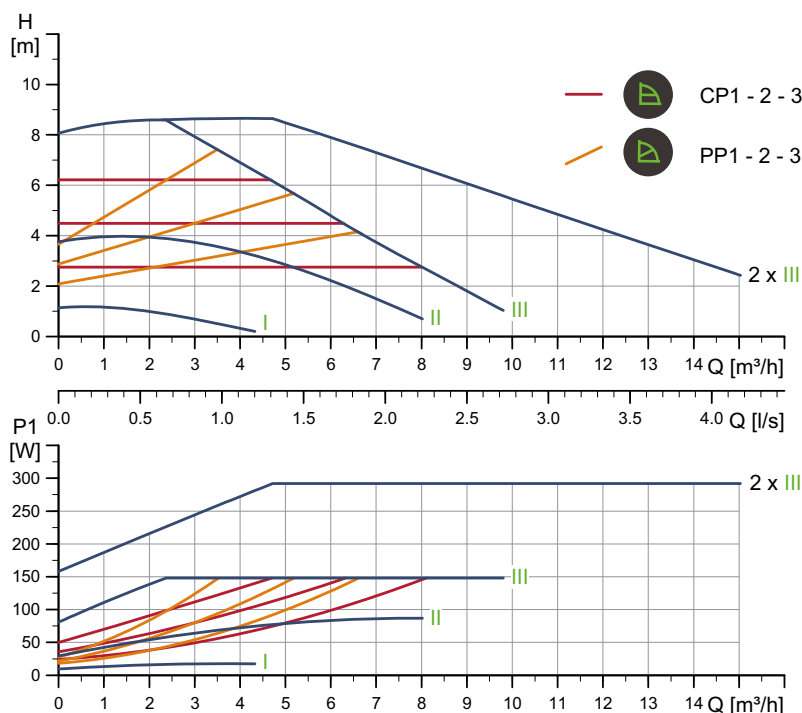

TM05 6367 4712

Speed	P1 [W]	I _{1/1} [A]
Min.	9	0.09
Max.	151	1.22

Connections: See section [Pipe connection](#), page 110.
 System pressure: Max. 1.0 MPa (10 bar).
 Liquid temperature: -10 to 110 °C (TF 110).
 Specific EEI: 0.23.

The pump incorporates overload protection.

Net weight [kg]	Gross weight [kg]	Ship. vol. [m³]
14.7	15.7	0.045

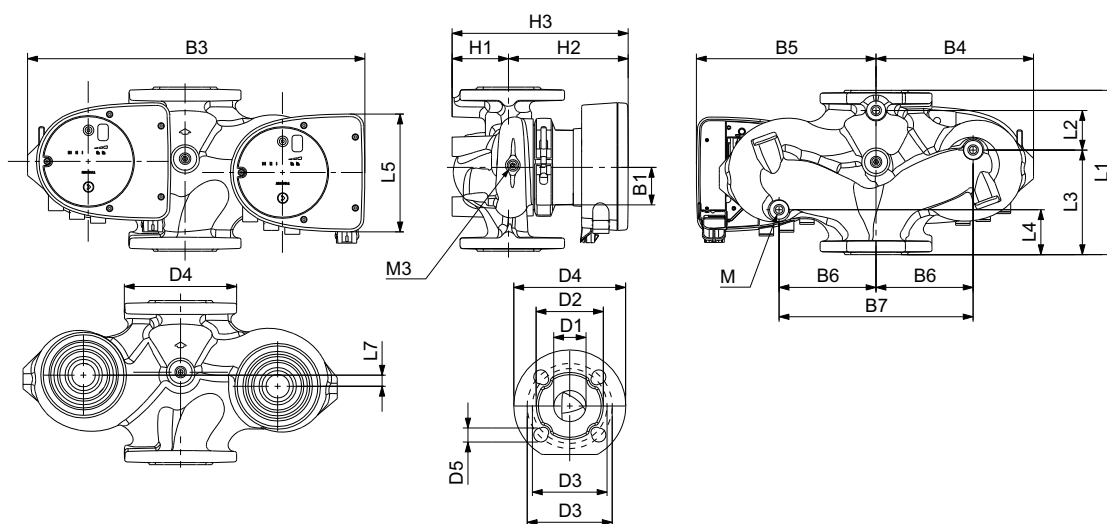

TM07 0069 4117

Pump type	Dimensions [mm]																			Rp		
	L1	L2	L3	L4	L5	L7	B1	B3	B4	B5	B6	B7	H1	H2	H3	D1	D2	D3	D4	D5	M	M3
MAGNA1 D 32-80 F	220	73	120	85	158	35	58	400	179	221	130	260	69	142	211	32	76	90/100	140	14/19	12	1/4

For product numbers, see page 115.

MAGNA1 32-100 F (N) PN 10

1 x 230 V, 50/60 Hz

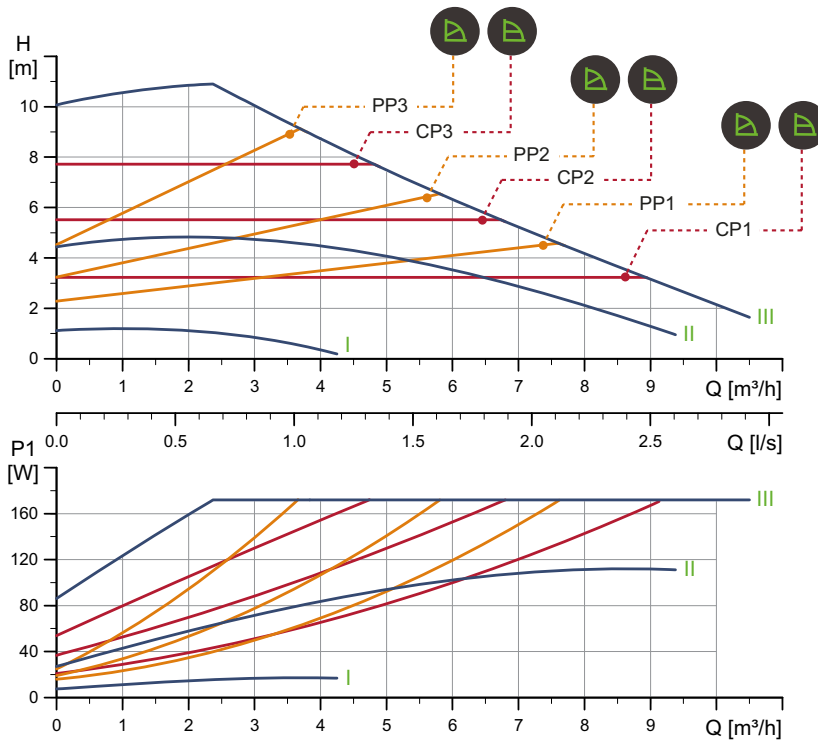

TM05 6331 4712

Speed	P1 [W]	I _{1/1} [A]
Min.	8	0.08
Max.	175	1.41

Connections: See section [Pipe connections](#), page 110.
 System pressure: Max. 1.0 MPa (10 bar).
 Liquid temperature: -10 to 110 °C (TF 110).
 Also available with: Stainless-steel pump housing, type N.
 Specific EEI: 0.20.

The pump incorporates overload protection.

Net weight [kg]	Gross weight [kg]	Ship. vol. [m ³]
7.4	8.4	0.016

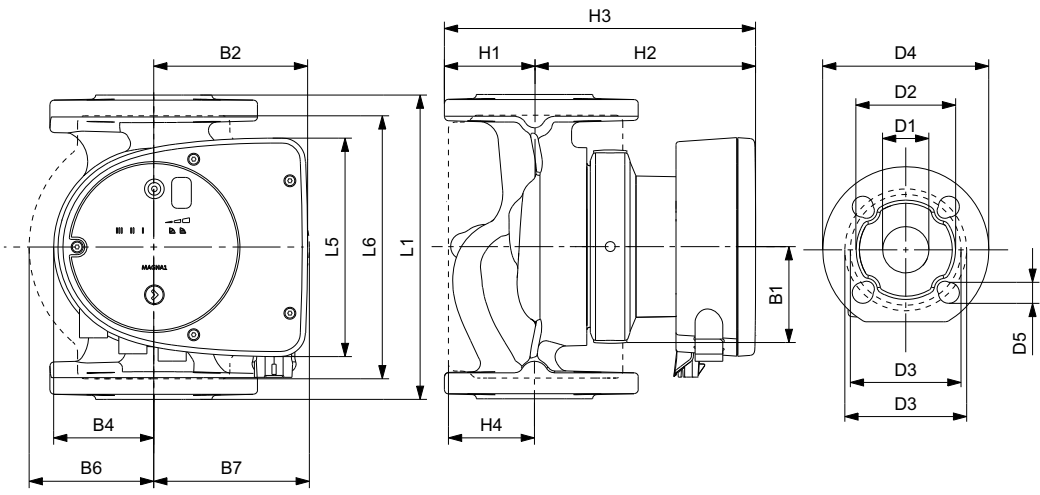

TM07 0067 4117

Pump type	Dimensions [mm]																
	L1	L5	L6	B1	B2	B4	B6	B7	H1	H2	H3	H4	D1	D2	D3	D4	D5
MAGNA1 32-100 F (N)	220	158	220	58	111	69	100	110	65	142	207	82	32	76	90/100	140	14/19

For product numbers, see page 115.

MAGNA1 D 32-100 F PN 10

1 x 230 V, 50/60 Hz

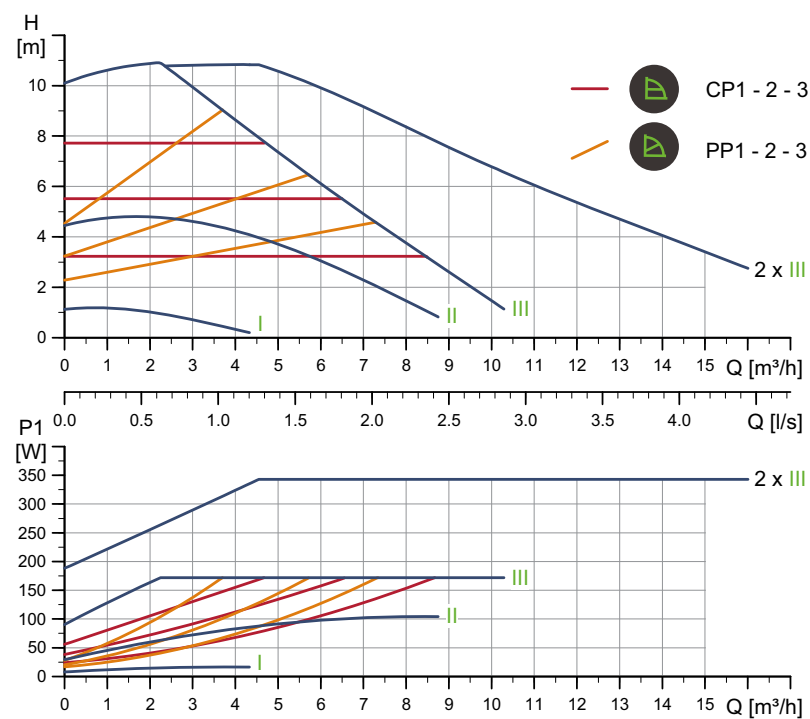

Speed	P1 [W]	I _{1/1} [A]
Min.	8	0.08
Max.	175	1.41

Connections: See section [Pipe connections](#), page 110.
 System pressure: Max. 1.0 MPa (10 bar).
 Liquid temperature: -10 to 110 °C (TF 110).
 Specific EEI: 0.22.

The pump incorporates overload protection.

Net weight [kg]	Gross weight [kg]	Ship. vol. [m³]
14.7	15.7	0.045

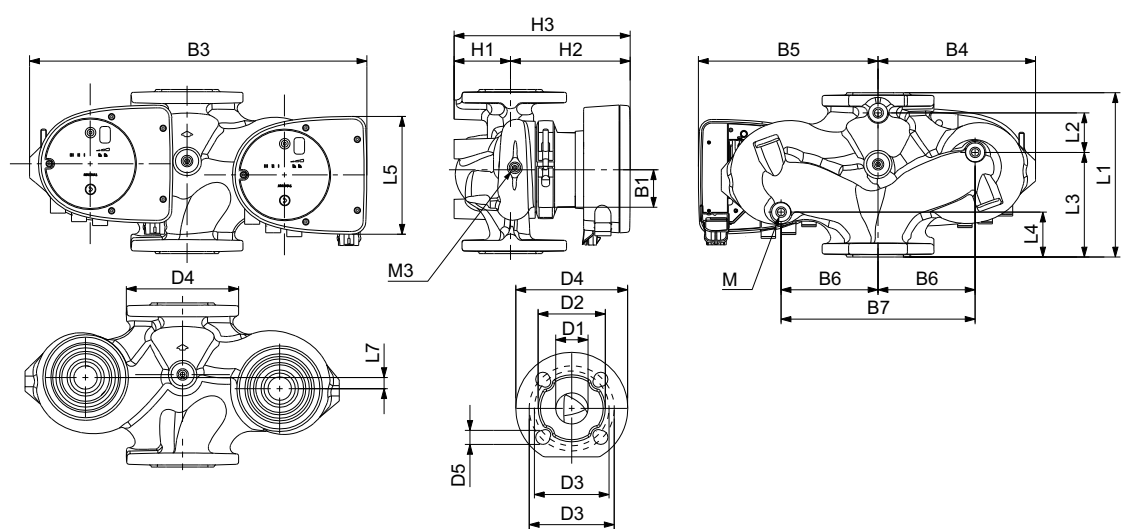

Pump type	Dimensions [mm]																			Rp		
	L1	L2	L3	L4	L5	L7	B1	B3	B4	B5	B6	B7	H1	H2	H3	D1	D2	D3	D4		D5	M
MAGNA1 D 32-100 F	220	73	120	85	158	35	58	400	179	221	130	260	69	142	211	32	76	90/100	140	14/19	12	1/4

For product numbers, see page 115.

TM05 6369 4712

TM07 0069 4117

MAGNA1 32-120 F (N) PN 10

1 x 230 V, 50/60 Hz

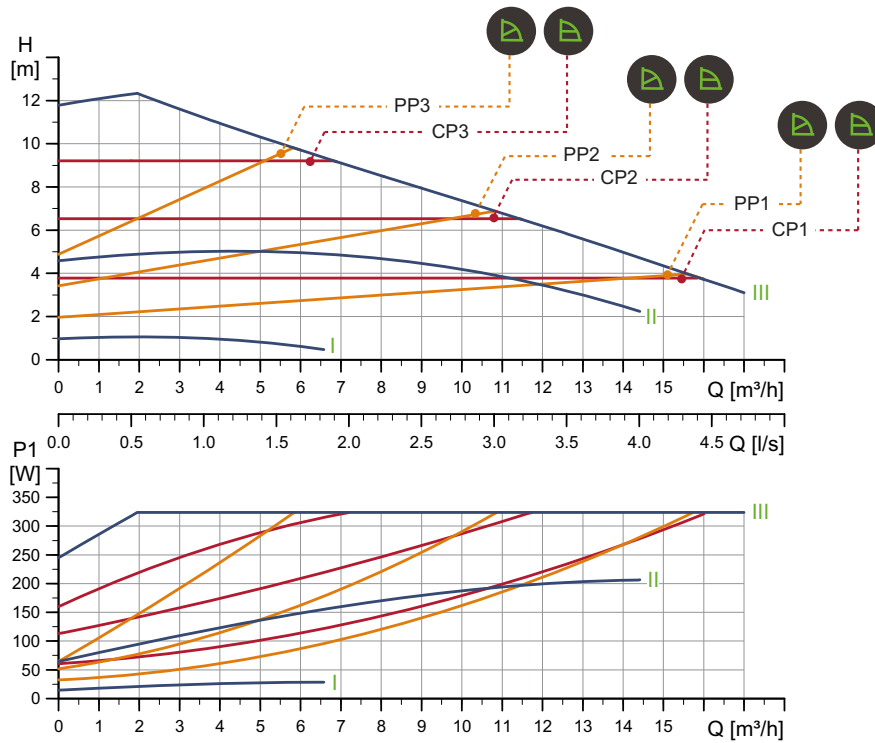

Speed	P1 [W]	I _{1/1} [A]
Min.	15	0.17
Max.	329	1.48

Connections: See section [Pipe connection](#), page 110.
 System pressure: Max. 1.0 MPa (10 bar).
 Liquid temperature: -10 to 110 °C (TF 110).
 Also available with: Stainless-steel pump housing, type N.
 Specific EEI: 0.20.

The pump incorporates overload protection.

Net weight [kg]	Gross weight [kg]	Ship. vol. [m ³]
15.4	17.1	0.040

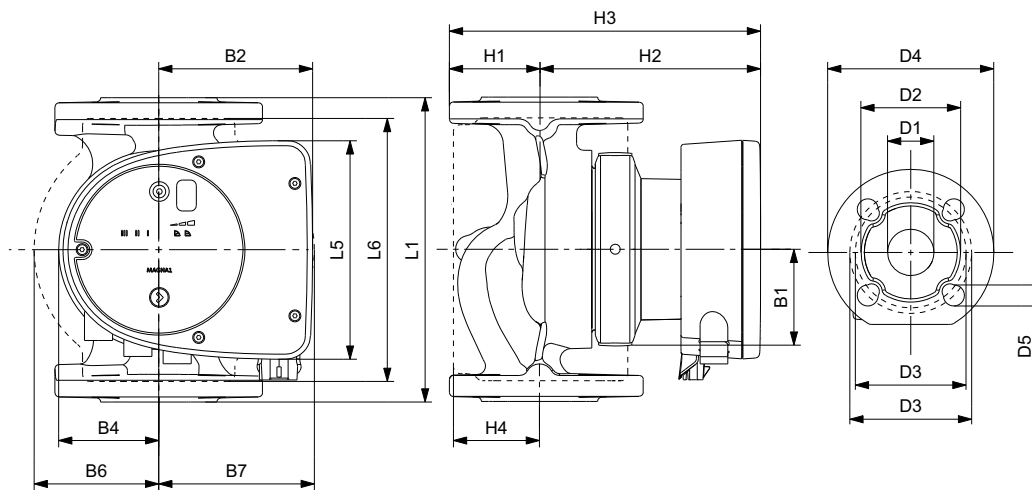

Pump type	Dimensions [mm]																
	L1	L5	L6	B1	B2	B4	B6	B7	H1	H2	H3	H4	D1	D2	D3	D4	D5
MAGNA1 32-120 F (N)	220	204	216	84	164	73	106	116	65	301	366	86	32	76	90/100	140	14/19

For product numbers, see page 115.

TM05 6387 4712

TM07 0067 4117

MAGNA1 D 32-120 F PN 10

1 x 230 V, 50/60 Hz

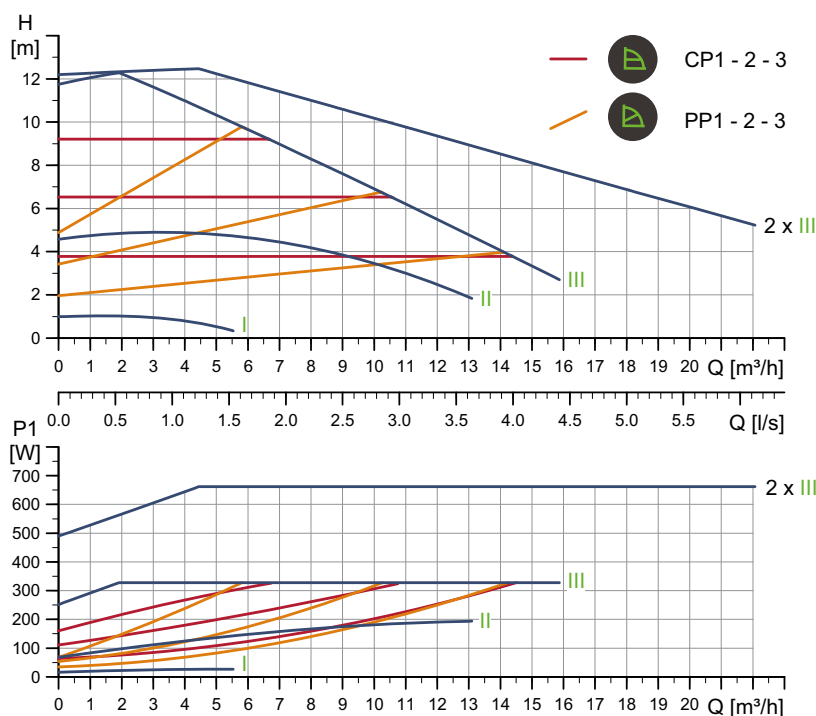

TM05 6334 4712

Speed	P1 [W]	I _{1/1} [A]
Min.	16.3	0.18
Max.	335	1.50

Connections: See section [Pipe connection](#), page 110.
 System pressure: Max. 1.0 MPa (10 bar).
 Liquid temperature: -10 to 110 °C (TF 110).
 Specific EEI: 0.22.

The pump incorporates overload protection.

Net weight [kg]	Gross weight [kg]	Ship. vol. [m ³]
29.8	33.7	0.087

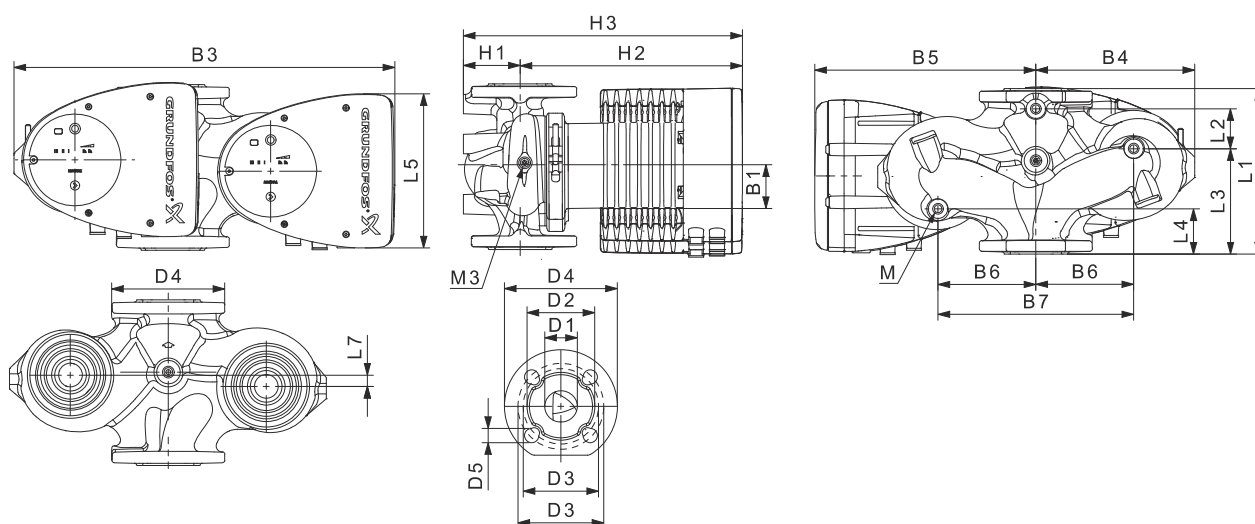

TM05 5937 3613

Pump type	Dimensions [mm]																				Rp	
	L1	L2	L3	L4	L5	L7	B1	B3	B4	B5	B6	B7	H1	H2	H3	D1	D2	D3	D4	D5		M
MAGNA1 D 32-120 F	220	97	90	50	204	50	84	502	210	294	130	260	68	300	368	32	76	90/100	140	14/19	12	1/4

For product numbers, see page 115.

MAGNA1 40-40 F (N)

1 x 230 V, 50/60 Hz

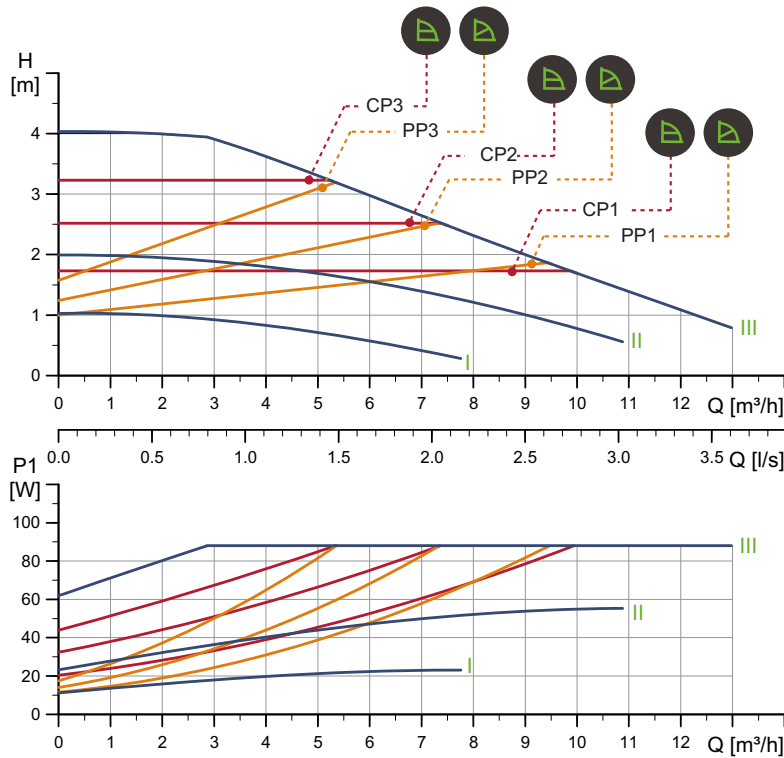

Speed	P1 [W]	I _{1/1} [A]
Min.	12	0.11
Max.	90	0.72

The pump incorporates overload protection.

Connections: See [Pipe connections](#), page 108.
 System pressure: Max. 1.0 MPa (10 bar).
 Liquid temperature: -10 to 110 °C (TF 110).
 Also available with: Stainless-steel pump housing, type N.
 Specific EEI: 0.20.

Net weight [kg]	Gross weight [kg]	Ship. vol. [m³]
9.5	10.5	0.016

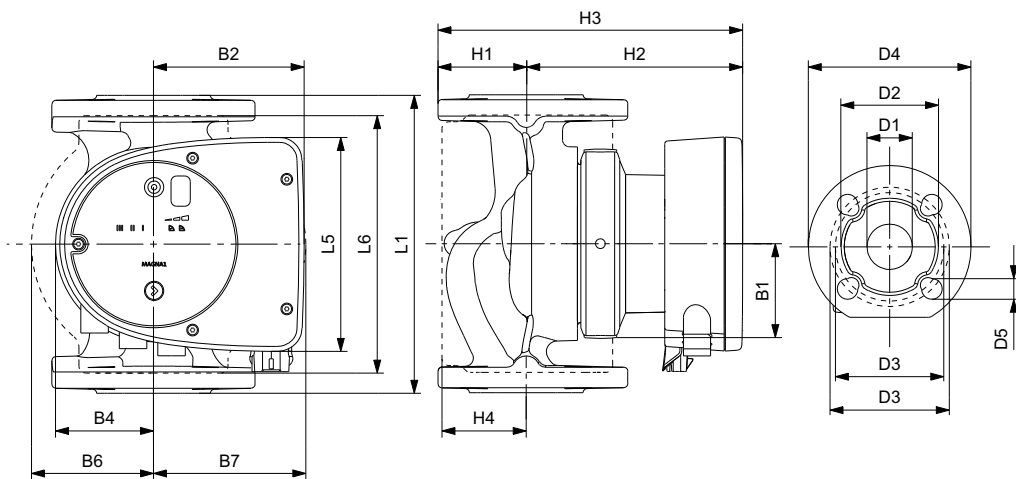

Pump type	Dimensions [mm]																
	L1	L5	L6	B1	B2	B4	B6	B7	H1	H2	H3	H4	D1	D2	D3	D4	D5
MAGNA1 40-40 F (N)	220	158	220	58	111	69	105	105	65	156	221	83	40	84	100/110	150	14/19

For product numbers, see page 114.

TM05 6332 4712

TM07 0067 4117

MAGNA1 D 40-40 F

1 x 230 V, 50/60 Hz

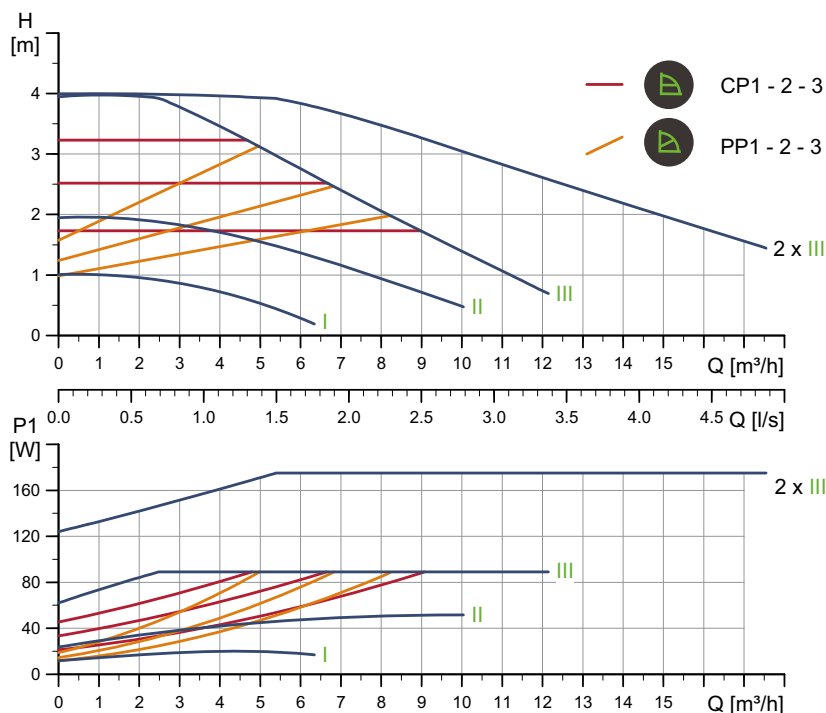

TM05 6370 4712

Speed	P1 [W]	I _{1/1} [A]
Min.	12	0.11
Max.	90	0.72

Connections: See [Pipe connections](#), page 110.
 System pressure: Max. 1.0 MPa (10 bar).
 Liquid temperature: -10 to 110 °C (TF 110).
 Specific EEI: 0.22.

The pump incorporates overload protection.

Net weight [kg]	Gross weight [kg]	Ship. vol. [m ³]
19.0	20.0	0.045

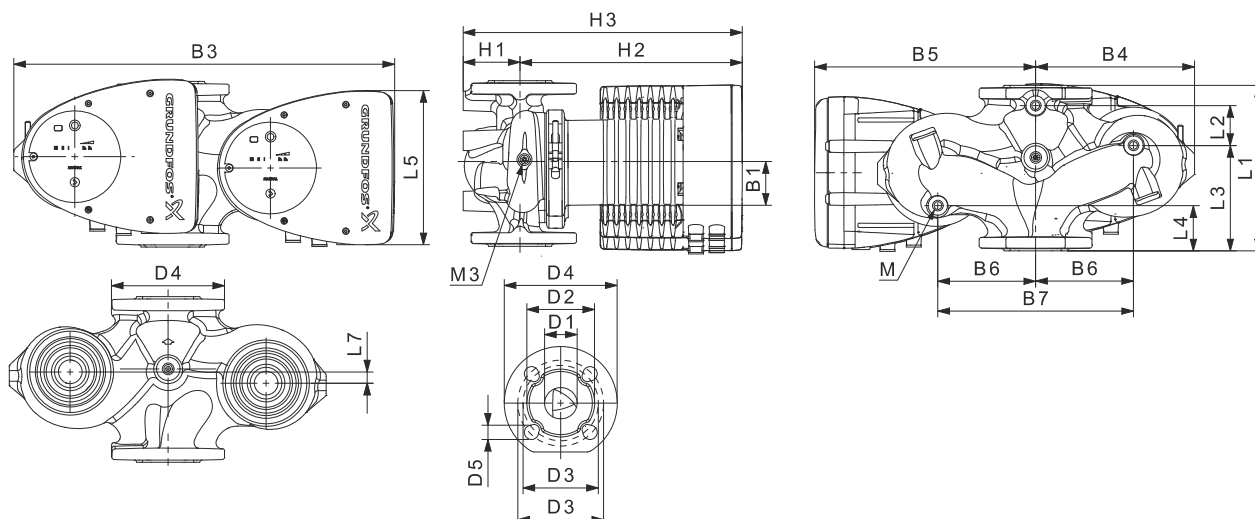

TM05 4960 3012

Pump type	Dimensions [mm]																				Rp	
	L1	L2	L3	L4	L5	L7	B1	B3	B4	B5	B6	B7	H1	H2	H3	D1	D2	D3	D4	D5	M	M3
MAGNA1 D 40-40 F	220	53	140	60	158	15	58	452	211	241	130	260	76	156	232	40	84	100/110	150	14/19	12	1/4

For product numbers, see page 115.

MAGNA1 40-60 F (N)

1 x 230 V, 50/60 Hz

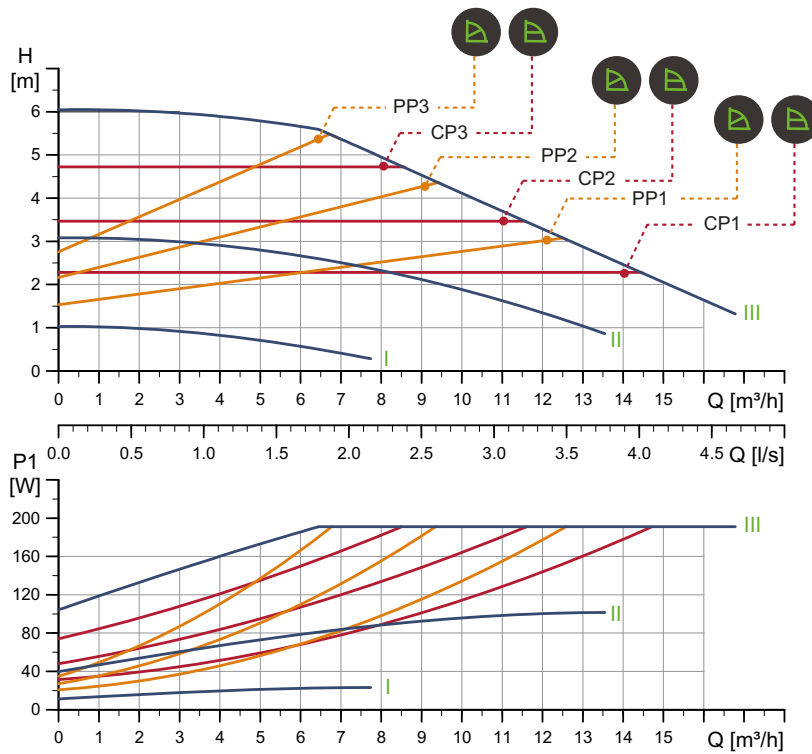

Speed	P1 [W]	I _{1/1} [A]
Min.	12	0.11
Max.	194	1.56

The pump incorporates overload protection.

Connections: See [Pipe connections](#), page 108.
 System pressure: Max. 1.0 MPa (10 bar).
 Liquid temperature: -10 to 110 °C (TF 110).
 Also available with: Stainless-steel pump housing, type N.
 Specific EEI: 0.20.

Net weight [kg]	Gross weight [kg]	Ship. vol. [m ³]
9.5	10.5	0.016

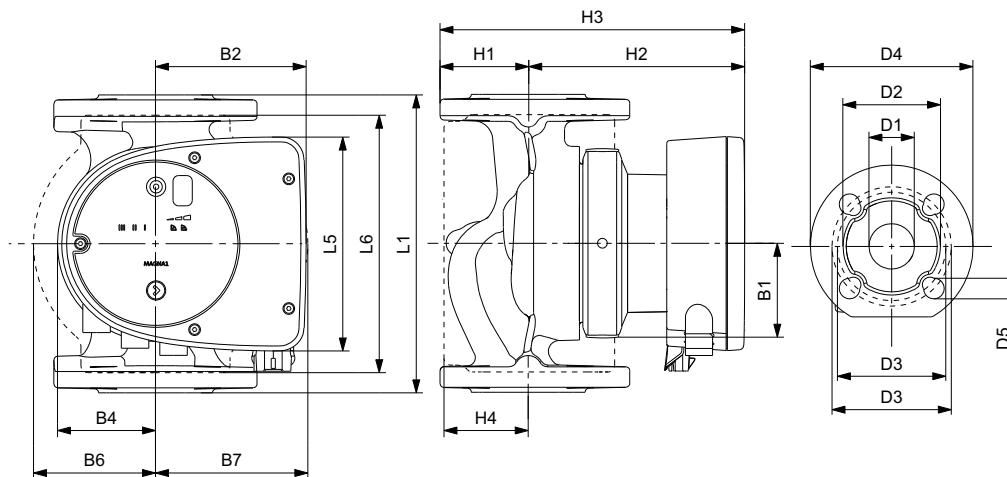

Pump type	Dimensions [mm]																
	L1	L5	L6	B1	B2	B4	B6	B7	H1	H2	H3	H4	D1	D2	D3	D4	D5
MAGNA1 40-60 F (N)	220	158	220	58	111	69	105	105	65	156	221	83	40	84	100/110	150	14/19

For product numbers, see page 114.

TM07 0565 0318

TM07 0067 4117

MAGNA1 D 40-60 F

1 x 230 V, 50/60 Hz

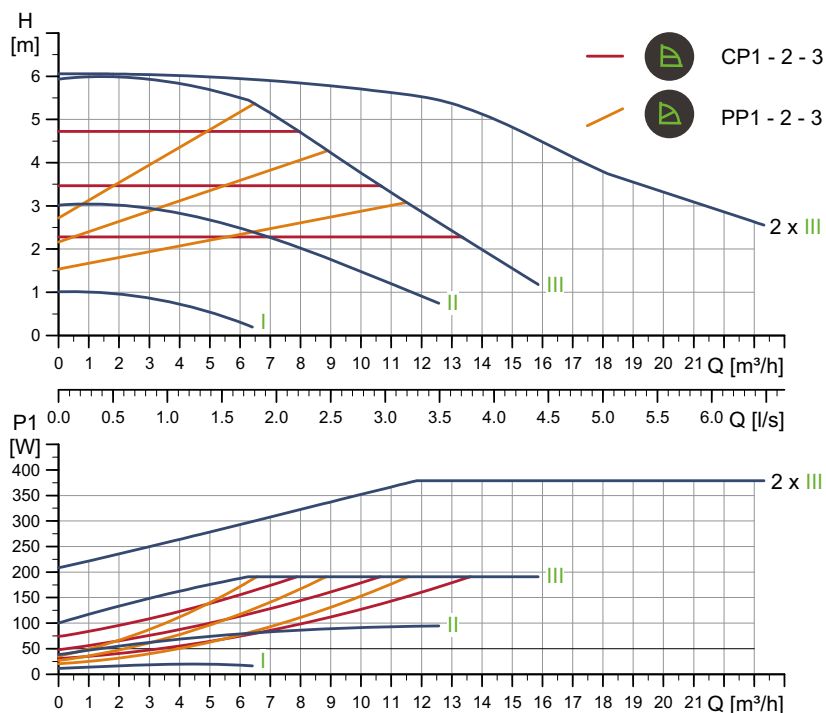

TM05 6371 4712

Speed	P1 [W]	I _{1/1} [A]
Min.	12	0.11
Max.	194	1.56

Connections: See [Pipe connections](#), page 110.
 System pressure: Max. 1.0 MPa (10 bar).
 Liquid temperature: -10 to 110 °C (TF 110).
 Specific EEI: 0.22.

The pump incorporates overload protection.

Net weight [kg]	Gross weight [kg]	Ship. vol. [m ³]
19.0	20.0	0.045

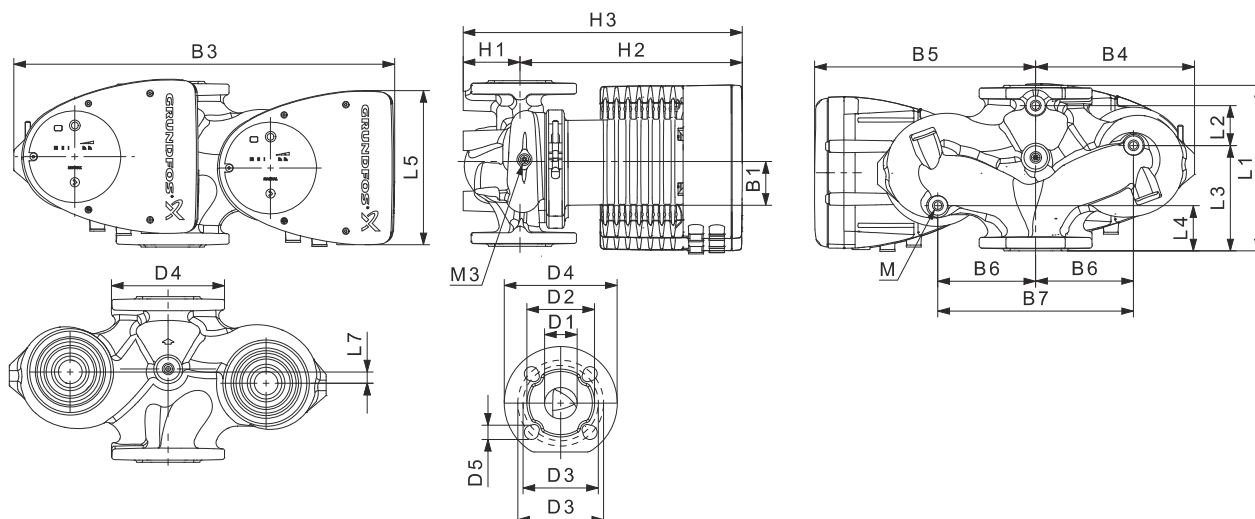

TM05 4960 3012

Pump type	Dimensions [mm]																				Rp	
	L1	L2	L3	L4	L5	L7	B1	B3	B4	B5	B6	B7	H1	H2	H3	D1	D2	D3	D4	D5	M	M3
MAGNA1 D 40-60 F	220	53	140	60	158	15	58	452	211	241	130	260	76	156	232	40	84	100/110	150	14/19	12	1/4

For product numbers, see page 115.

MAGNA1 40-80 F (N) PN 10

1 x 230 V, 50/60 Hz

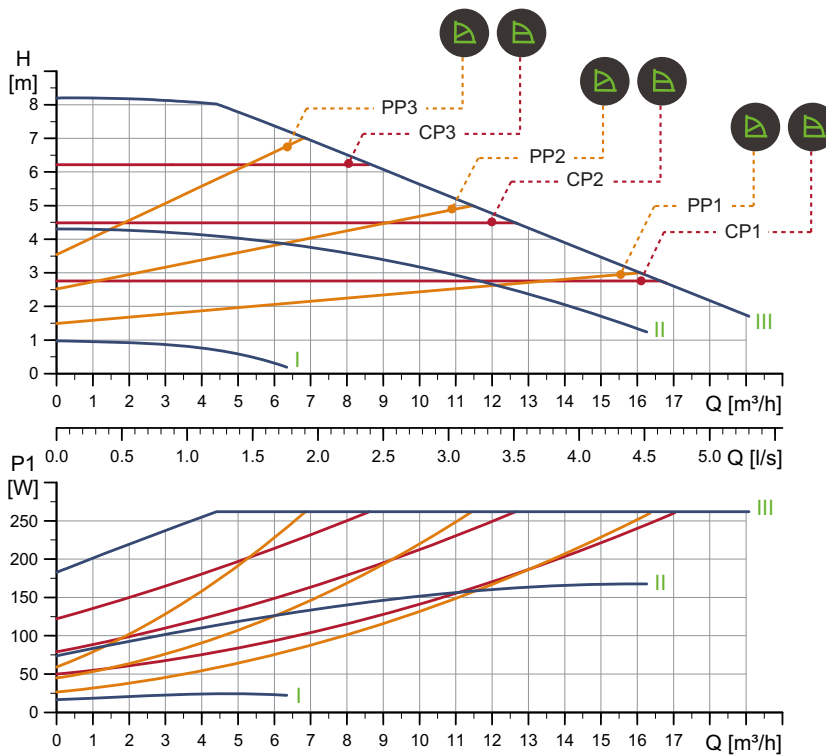

Speed	P1 [W]	I _{1/1} [A]
Min.	17	0.19
Max.	267	1.18

The pump incorporates overload protection.

Connections: See section [Pipe connection](#), page 110.
 System pressure: Max. 1.0 MPa (10 bar).
 Liquid temperature: -10 to 110 °C (TF 110).
 Also available with: Stainless-steel pump housing, type N.
 Specific EEI: 0.20.

Net weight [kg]	Gross weight [kg]	Ship. vol. [m³]
16.5	18.2	0.040

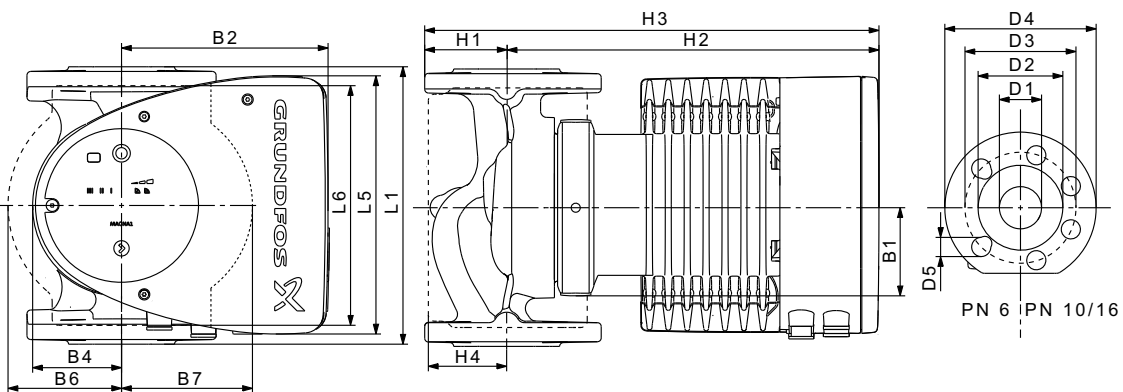

Pump type	Dimensions [mm]																
	L1	L5	L6	B1	B2	B4	B6	B7	H1	H2	H3	H4	D1	D2	D3	D4	D5
MAGNA1 40-80 F (N)	220	204	220	84	164	73	106	128	65	304	369	83	40	84	100/110	150	14/19

For product numbers, see page 115.

TM05 6288 4712

TM05 5276 3512

MAGNA1 D 40-80 F PN 10

1 x 230 V, 50/60 Hz

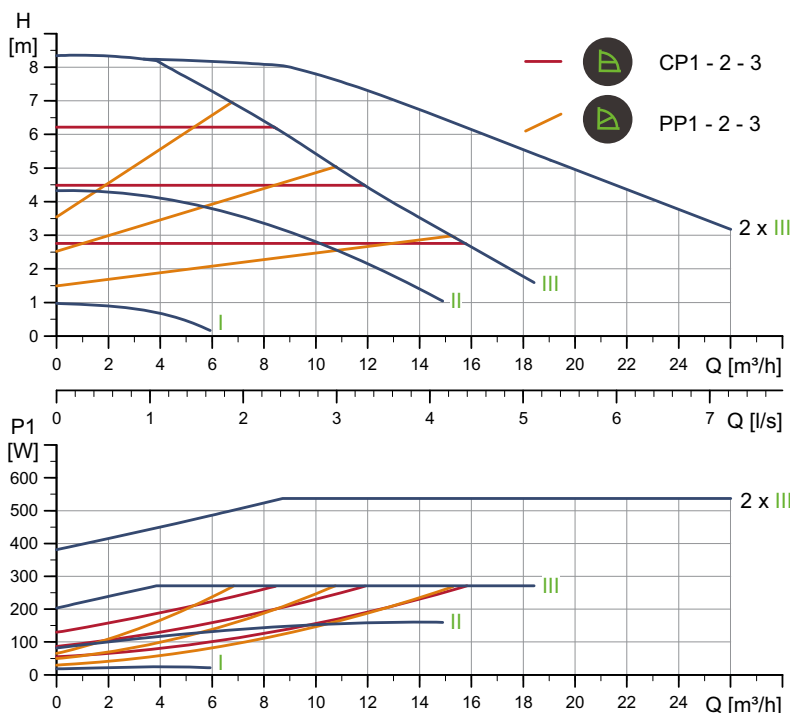

TM05 3733 1912

Speed	P1 [W]	I _{1/1} [A]
Min.	18.4	0.20
Max.	276	1.25

Connections: See section [Pipe connection](#), page 110.
 System pressure: Max. 1.0 MPa (10 bar).
 Liquid temperature: -10 to 110 °C (TF 110).
 Specific EEI: 0.23.

The pump incorporates overload protection.

Net weight [kg]	Gross weight [kg]	Ship. vol. [m ³]
32.3	36.2	0.087

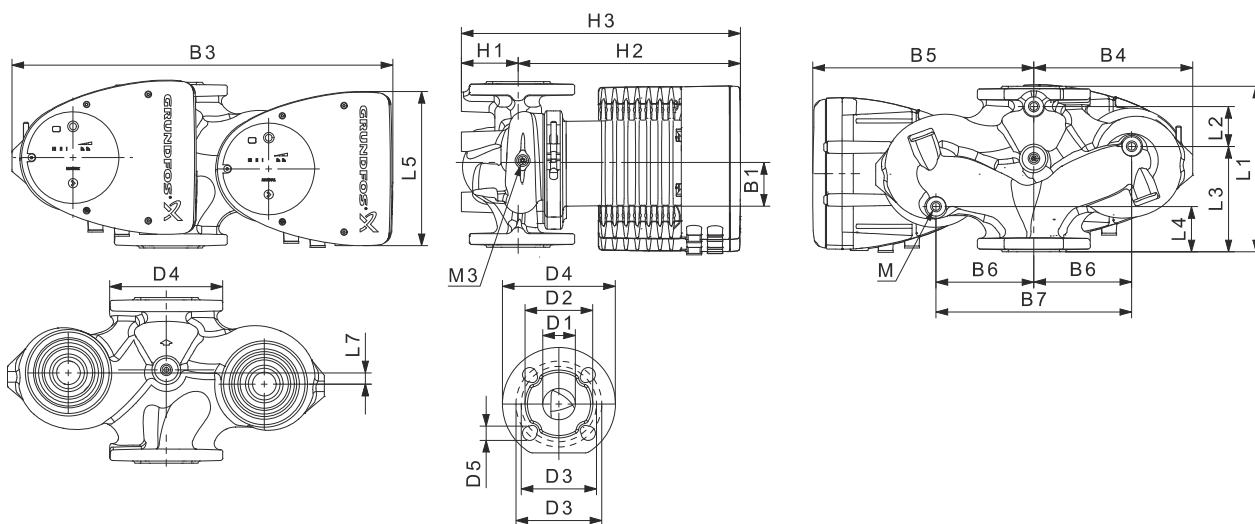

TM05 5937 3613

Pump type	Dimensions [mm]																				Rp	
	L1	L2	L3	L4	L5	L7	B1	B3	B4	B5	B6	B7	H1	H2	H3	D1	D2	D3	D4	D5		M
MAGNA1 D 40-80 F	220	53	140	60	204	15	84	502	210	294	130	260	76	303	379	40	84	100/110	150	14/19	12	1/4

For product numbers, see page 115.

MAGNA1 40-100 F (N) PN 10

1 x 230 V, 50/60 Hz

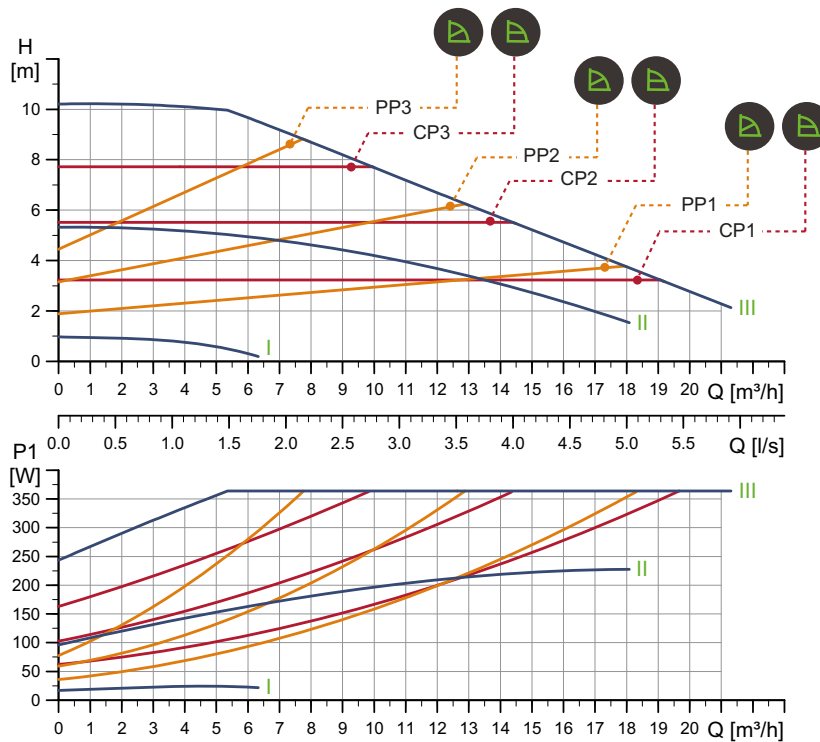

Speed	P1 [W]	I _{1/1} [A]
Min.	17	0.19
Max.	370	1.65

The pump incorporates overload protection.

Connections: See section [Pipe connection](#), page 110.
 System pressure: Max. 1.0 MPa (10 bar).
 Liquid temperature: -10 to 110 °C (TF 110).
 Also available with: Stainless-steel pump housing, type N.
 Specific EEI: 0.20.

Net weight [kg]	Gross weight [kg]	Ship. vol. [m³]
16.5	18.2	0.040

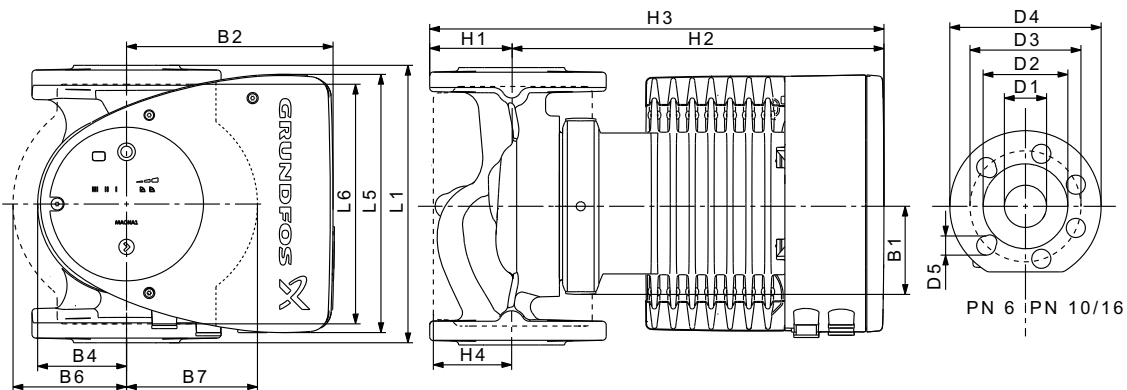

Pump type	Dimensions [mm]																
	L1	L5	L6	B1	B2	B4	B6	B7	H1	H2	H3	H4	D1	D2	D3	D4	D5
MAGNA1 40-100 F (N)	220	204	220	84	164	73	106	128	65	304	369	83	40	84	100/110	150	14/19

For product numbers, see page 115.

TM05 6289 4712

TM05 5276 3512

MAGNA1 D 40-100 F PN 10

1 x 230 V, 50/60 Hz

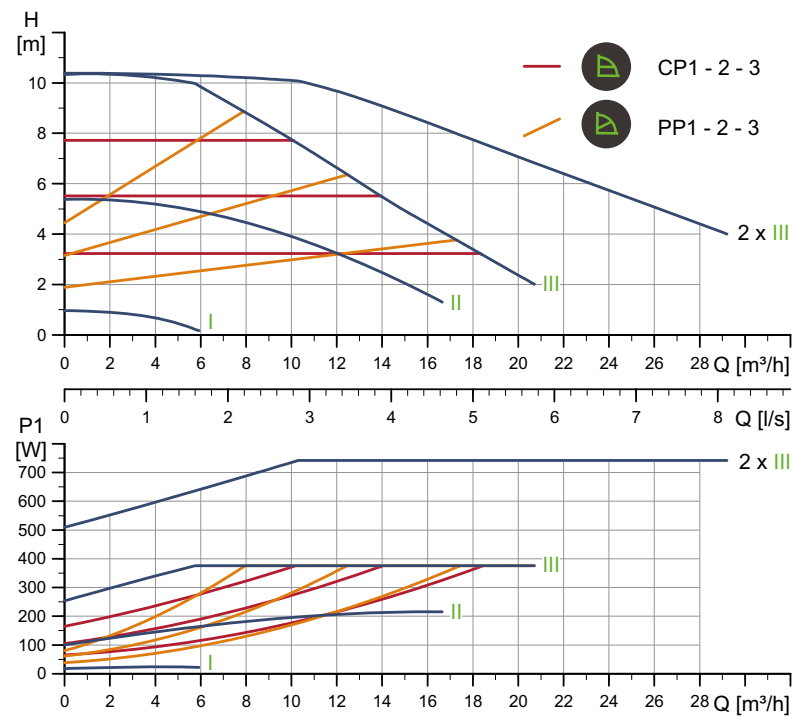

Speed	P1 [W]	I _{1/1} [A]
Min.	18.1	0.20
Max.	383	1.70

Connections: See section [Pipe connection](#), page 110.
 System pressure: Max. 1.0 MPa (10 bar).
 Liquid temperature: -10 to 110 °C (TF 110).
 Specific EEI: 0.23.

The pump incorporates overload protection.

Net weight [kg]	Gross weight [kg]	Ship. vol. [m ³]
32.3	36.2	0.087

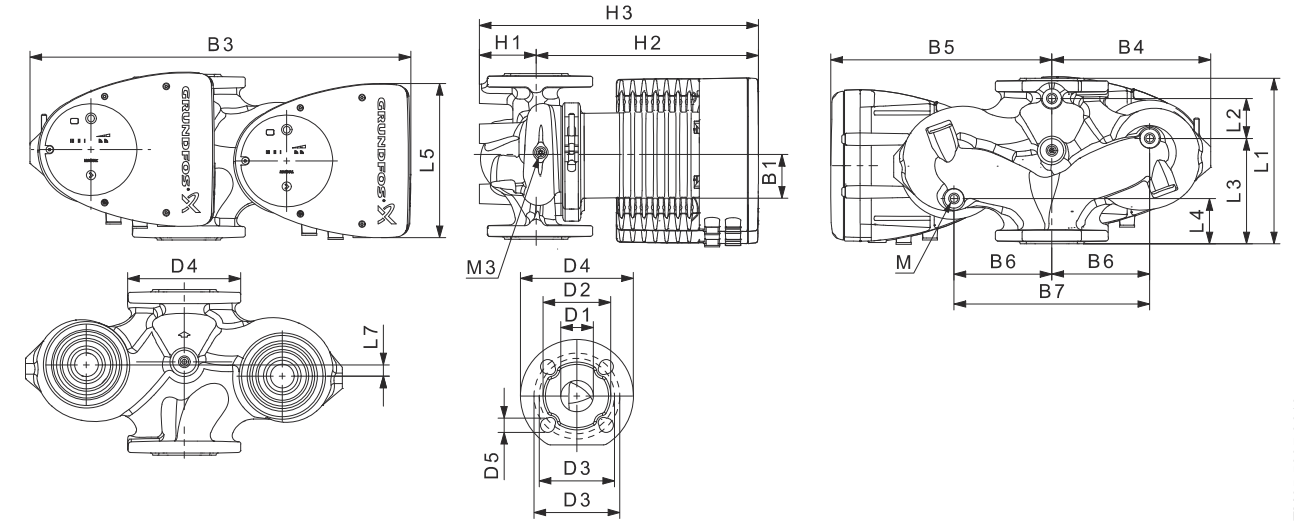

Pump type	Dimensions [mm]																				Rp	
	L1	L2	L3	L4	L5	L7	B1	B3	B4	B5	B6	B7	H1	H2	H3	D1	D2	D3	D4	D5	M	M3
MAGNA1 D 40-100 F	220	53	140	60	204	15	84	502	210	294	130	260	76	303	379	40	84	100/110	150	14/19	12	1/4

For product numbers, see page 115.

TM05 6336 4712

TM05 5937 3613

MAGNA1 40-120 F (N) PN 10

1 x 230 V, 50/60 Hz

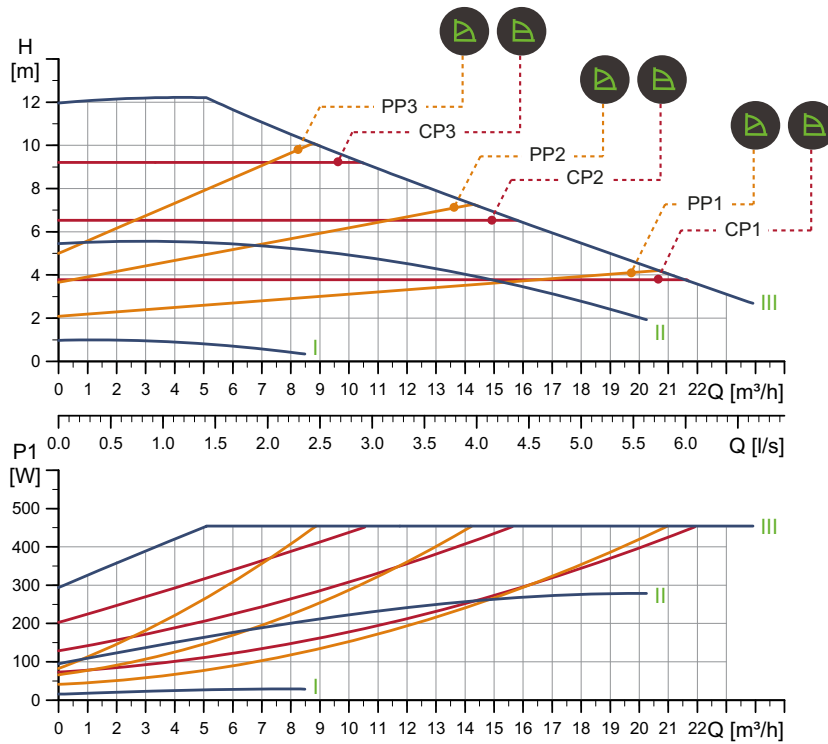

Speed	P1 [W]	I _{1/1} [A]
Min.	15	0.18
Max.	463	2.05

The pump incorporates overload protection.

Connections: See section [Pipe connection](#), page 110.
 System pressure: Max. 1.0 MPa (10 bar).
 Liquid temperature: -10 to 110 °C (TF 110).
 Also available with: Stainless-steel pump housing, type N.
 Specific EEI: 0.20.

Net weight [kg]	Gross weight [kg]	Ship. vol. [m³]
16.2	17.7	0.040

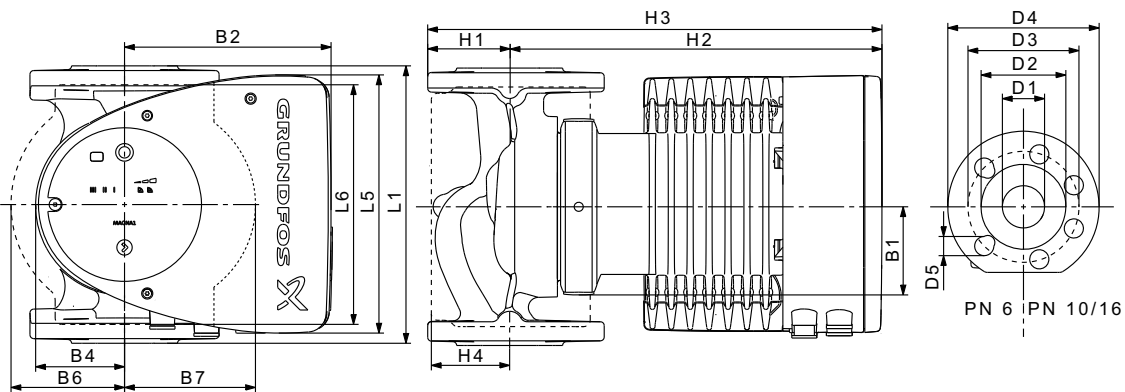

Pump type	Dimensions [mm]																
	L1	L5	L6	B1	B2	B4	B6	B7	H1	H2	H3	H4	D1	D2	D3	D4	D5
MAGNA1 40-120 F (N)	250	204	220	84	164	73	106	128	65	304	369	83	40	84	100/110	150	14/19

For product numbers, see page 115.

TM05 6290 4712

TM05 5276 3512

MAGNA1 D 40-120 F PN 10

1 x 230 V, 50/60 Hz

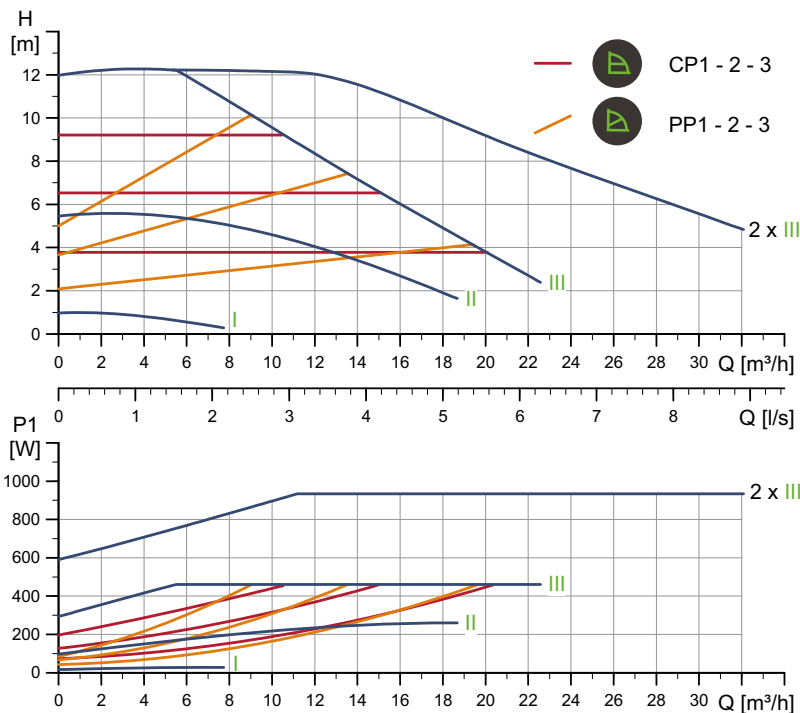

TM05 6337 4712

Speed	P1 [W]	I _{1/1} [A]
Min.	17	0.19
Max.	476	2.10

Connections: See section [Pipe connection](#), page 110.
 System pressure: Max. 1.0 MPa (10 bar).
 Liquid temperature: -10 to 110 °C (TF 110).
 Specific EEI: 0.22.

The pump incorporates overload protection.

Net weight [kg]	Gross weight [kg]	Ship. vol. [m³]
31.4	35.3	0.087

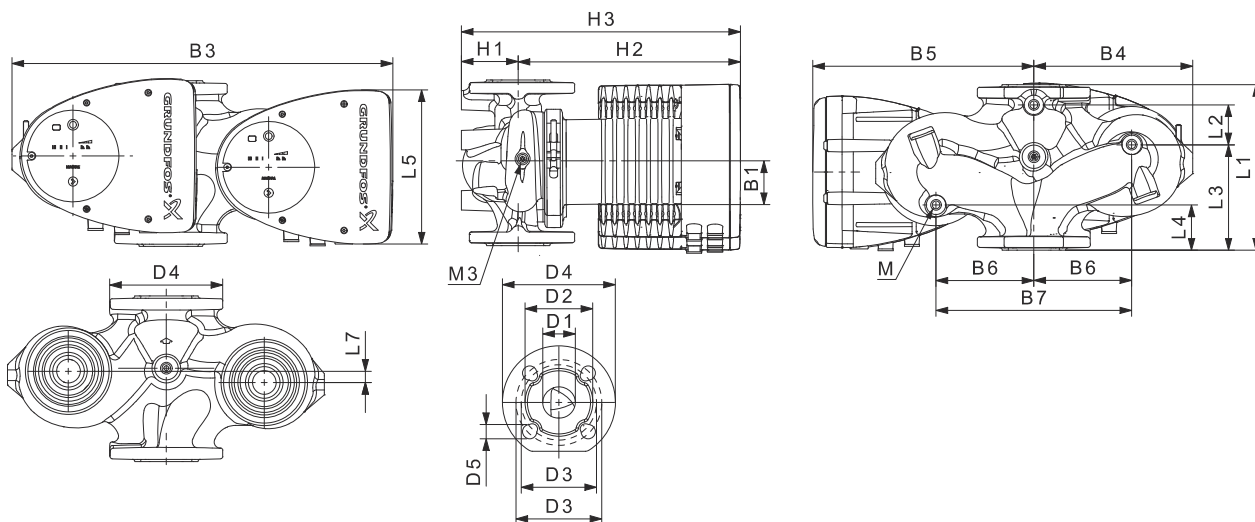

TM05 5937 3613

Pump type	Dimensions [mm]																				Rp	
	L1	L2	L3	L4	L5	L7	B1	B3	B4	B5	B6	B7	H1	H2	H3	D1	D2	D3	D4	D5		M
MAGNA1 D 40-120 F	250	58	155	75	204	0	84	512	220	294	130	260	69	303	372	40	84	100/110	150	14/19	12	1/4

For product numbers, see page 115.

MAGNA1 40-150 F (N) PN 10

1 x 230 V, 50/60 Hz

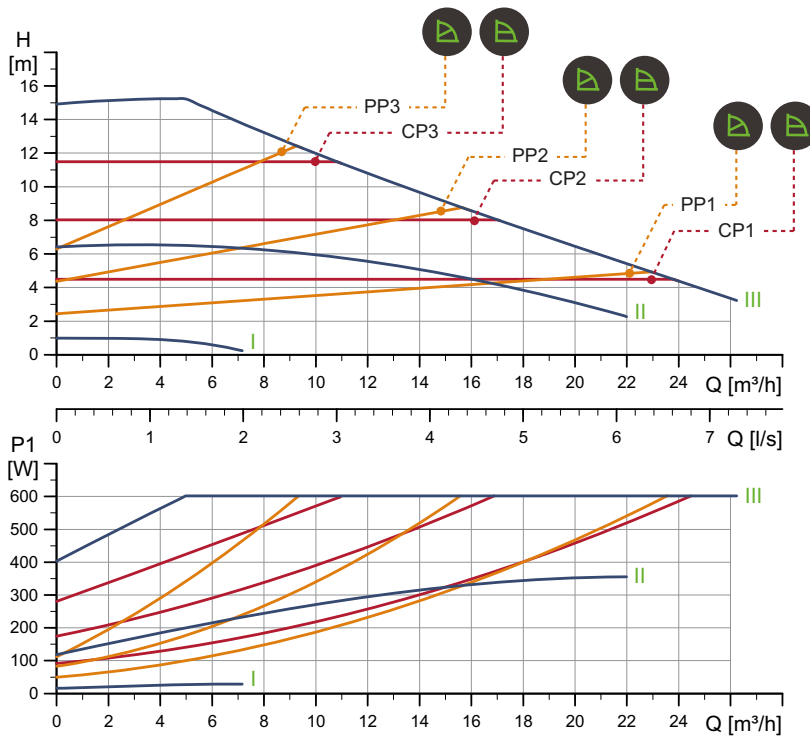

TM05 6291 4712

Speed	P1 [W]	I _{1/1} [A]
Min.	16	0.18
Max.	615	2.71

Connections: See section [Pipe connection](#), page 110.
 System pressure: Max. 1.0 MPa (10 bar).
 Liquid temperature: -10 to 110 °C (TF 110).
 Also available with: Stainless-steel pump housing, type N.
 Specific EEI: 0.20.

The pump incorporates overload protection.

Net weight [kg]	Gross weight [kg]	Ship. vol. [m³]
16.2	17.7	0.040

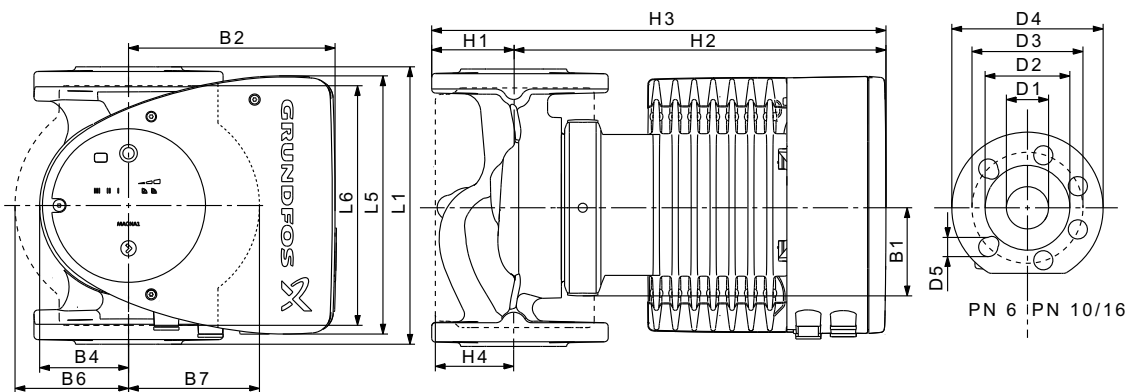

TM05 6276 3512

Pump type	Dimensions [mm]																
	L1	L5	L6	B1	B2	B4	B6	B7	H1	H2	H3	H4	D1	D2	D3	D4	D5
MAGNA1 40-150 F (N)	250	204	220	84	164	73	106	128	65	304	369	83	40	84	100/110	150	14/19

For product numbers, see page 115.

MAGNA1 D 40-150 F PN 10

1 x 230 V, 50/60 Hz

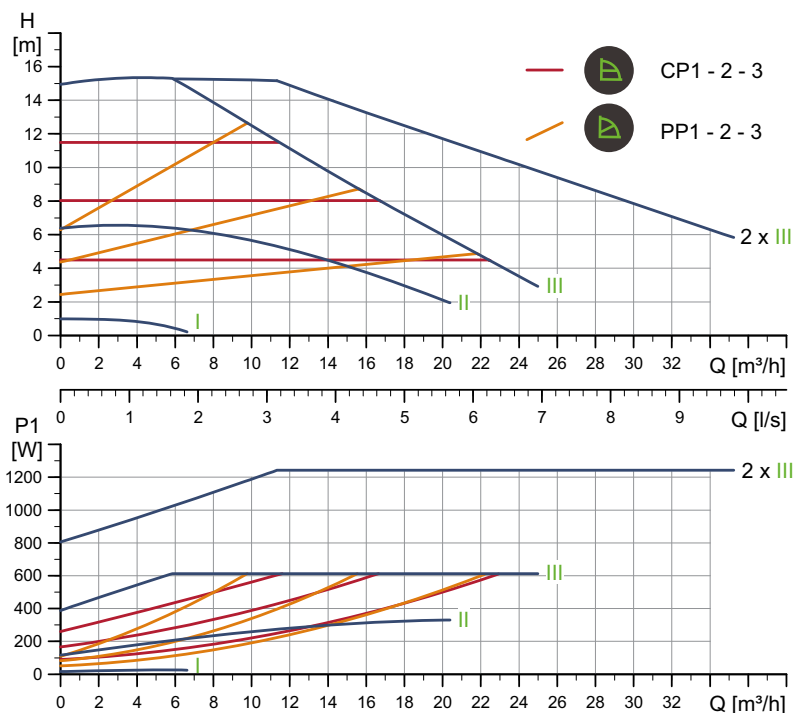

TM05 6338 4712

Speed	P1 [W]	I _{1/1} [A]
Min.	16.9	0.18
Max.	630	2.77

Connections: See section [Pipe connection](#), page 110.
 System pressure: Max. 1.0 MPa (10 bar).
 Liquid temperature: -10 to 110 °C (TF 110).
 Specific EEI: 0.21.

The pump incorporates overload protection.

Net weight [kg]	Gross weight [kg]	Ship. vol. [m ³]
31.4	35.3	0.087

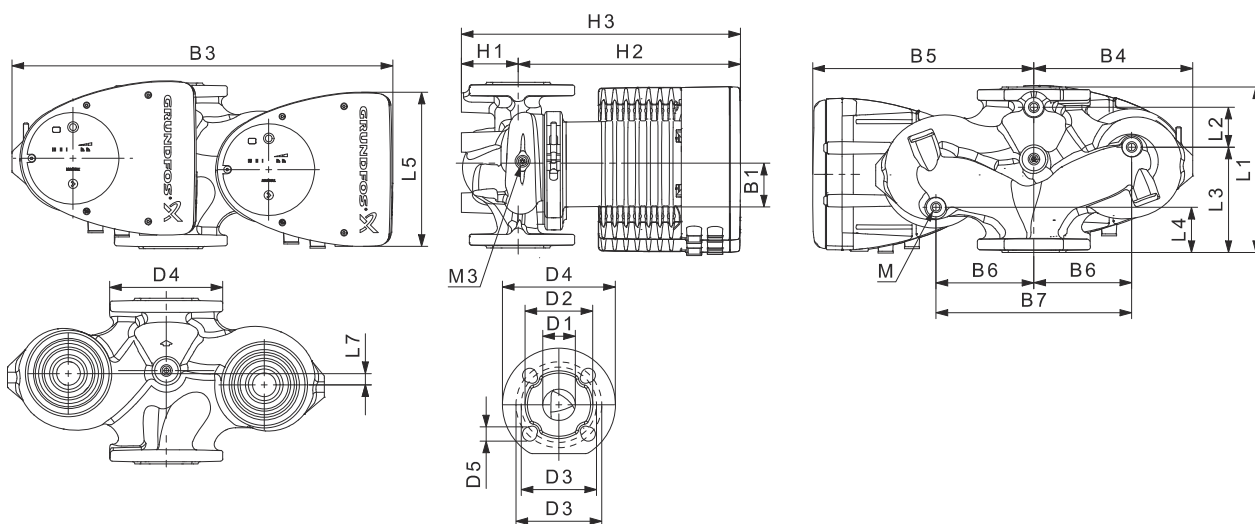

TM05 5937 3613

Pump type	Dimensions [mm]																				Rp	
	L1	L2	L3	L4	L5	L7	B1	B3	B4	B5	B6	B7	H1	H2	H3	D1	D2	D3	D4	D5	M	M3
MAGNA1 D 40-150 F	250	58	155	75	204	0	84	512	220	294	130	260	69	303	372	40	84	100/110	150	14/19	12	1/4

For product numbers, see page 115.

MAGNA1 40-180 F (N) PN 10

1 x 230 V, 50/60 Hz

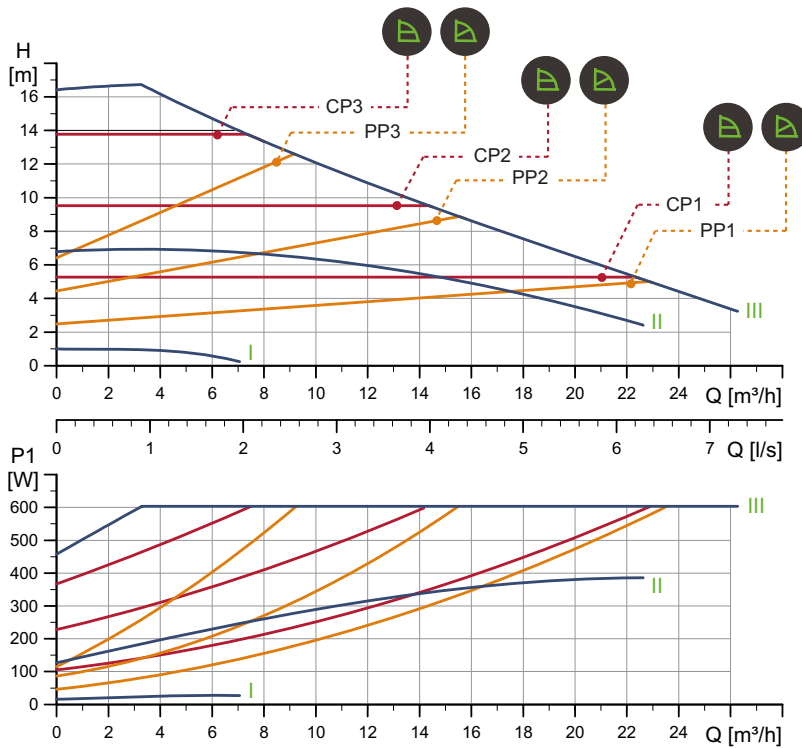

TM05 6292 4712

Speed	P1 [W]	I _{1/1} [A]
Min.	16	0.22
Max.	615	2.71

Connections: See section *Pipe connection*, page 110.
 System pressure: Max. 1.0 MPa (10 bar).
 Liquid temperature: -10 to 110 °C (TF 110).
 Also available with: Stainless-steel pump housing, type N.
 Specific EEI: 0.20.

The pump incorporates overload protection.

Net weight [kg]	Gross weight [kg]	Ship. vol. [m³]
16.2	17.7	0.040

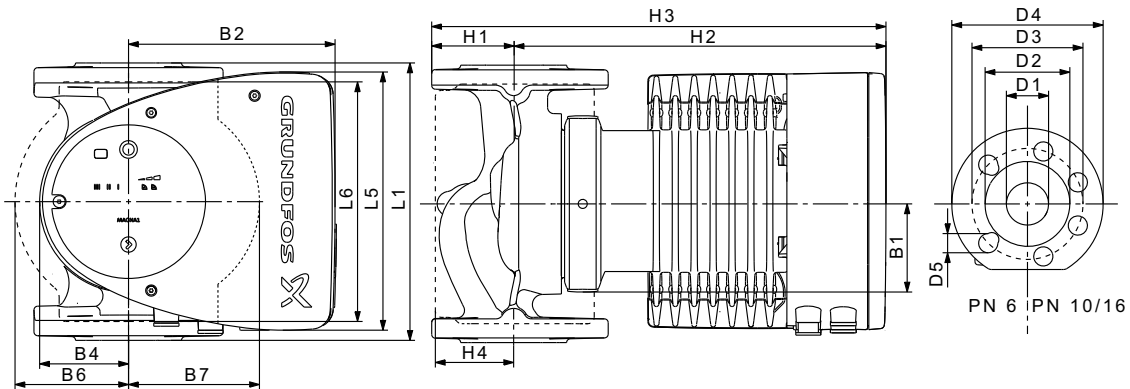

TM05 5276 3512

Pump type	Dimensions [mm]																
	L1	L5	L6	B1	B2	B4	B6	B7	H1	H2	H3	H4	D1	D2	D3	D4	D5
MAGNA1 40-180 F (N)	250	204	220	84	164	73	106	128	65	304	369	83	40	84	100/110	150	14/19

For product numbers, see page 115.

MAGNA1 D 40-180 F PN 10

1 x 230 V, 50/60 Hz

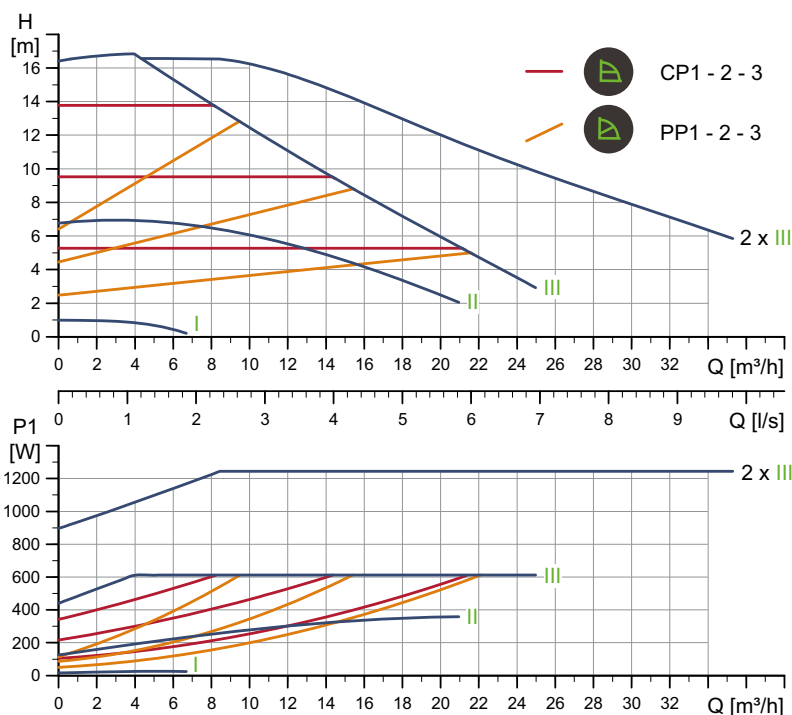

TM05 6339 4712

Speed	P1 [W]	I _{1/1} [A]
Min.	15.4	0.19
Max.	629	2.75

Connections: See section [Pipe connection](#), page 110.
 System pressure: Max. 1.0 MPa (10 bar).
 Liquid temperature: -10 to 110 °C (TF 110).
 Specific EEI: 0.21.

The pump incorporates overload protection.

Net weight [kg]	Gross weight [kg]	Ship. vol. [m³]
31.4	35.3	0.087

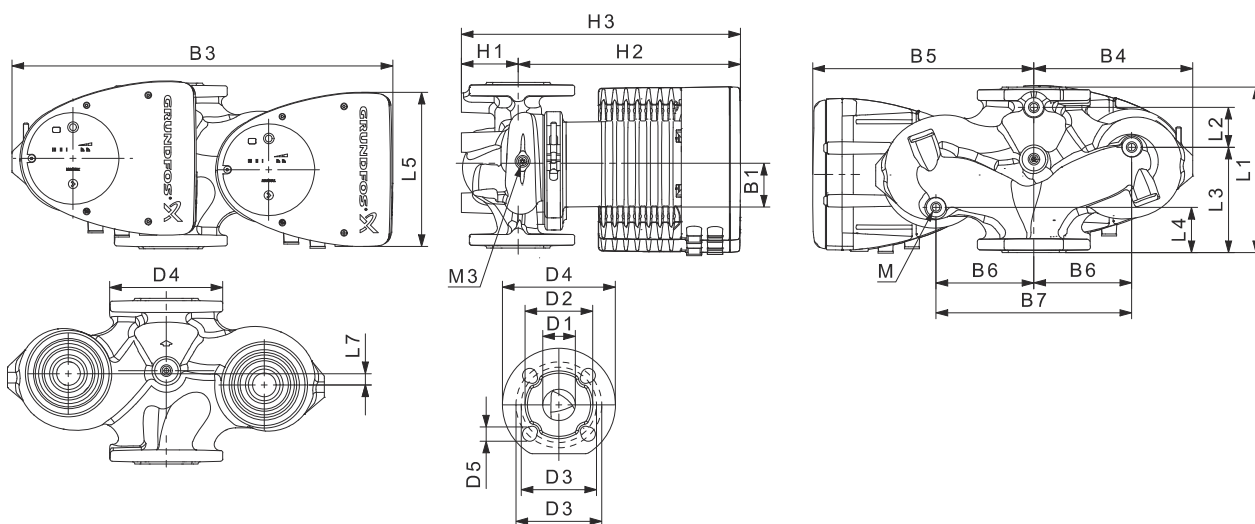

TM05 5937 3613

Pump type	Dimensions [mm]																			Rp		
	L1	L2	L3	L4	L5	L7	B1	B3	B4	B5	B6	B7	H1	H2	H3	D1	D2	D3	D4	D5	M	M3
MAGNA1 D 40-180 F	250	58	155	75	204	0	84	512	220	294	130	260	69	303	372	40	84	100/110	150	14/19	12	1/4

For product numbers, see page 115.

MAGNA1 D 50-40 F PN 10

1 x 230 V, 50/60 Hz

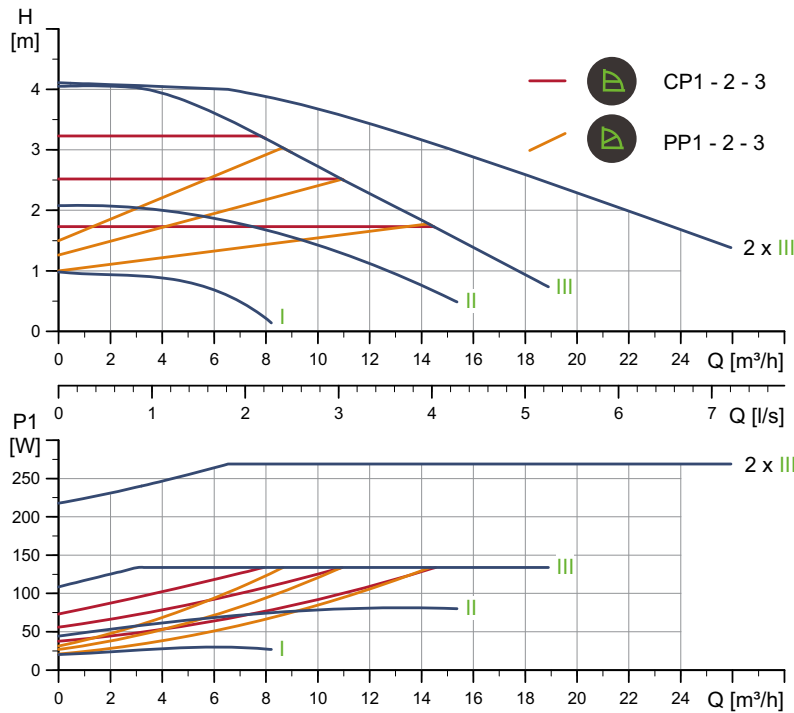

Speed	P1 [W]	I _{1/1} [A]
Min.	21.1	0.22
Max.	137	0.65

Connections: See section [Pipe connection](#), page 110.
 System pressure: Max. 1.0 MPa (10 bar).
 Liquid temperature: -10 to 110 °C (TF 110).
 Specific EEI: 0.23.

The pump incorporates overload protection.

Net weight [kg]	Gross weight [kg]	Ship. vol. [m³]
34.3	42.0	0.132

TM05 6340 4712

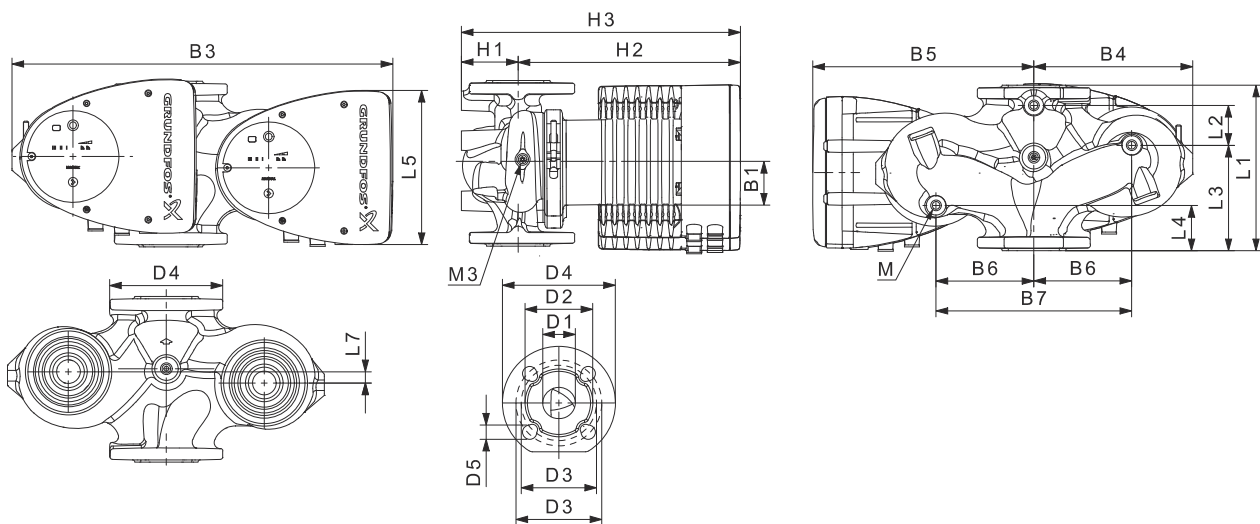

TM05 5937 3613

Pump type	Dimensions [mm]																				Rp	
	L1	L2	L3	L4	L5	L7	B1	B3	B4	B5	B6	B7	H1	H2	H3	D1	D2	D3	D4	D5	M	M3
MAGNA1 D 50-40 F	240	48	160	45	204	45	84	515	221	294	130	260	75	304	379	50	102	110/125	165	14/19	12	1/4

For product numbers, see page 115.

MAGNA1 50-60 F (N) PN 10

1 x 230 V, 50/60 Hz

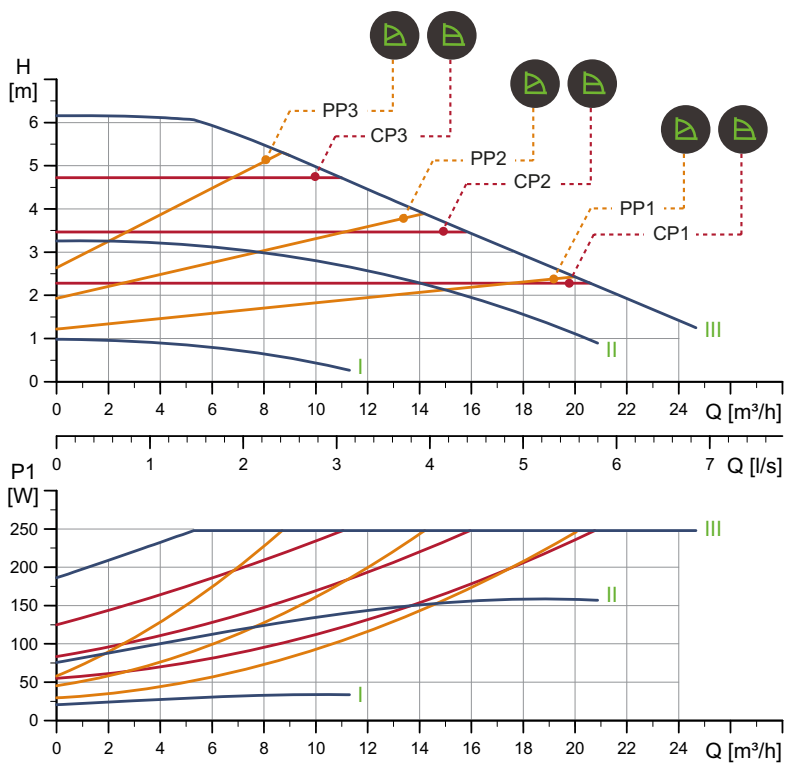

TM05 6294 4712

Speed	P1 [W]	I _{1/1} [A]
Min.	20.9	0.22
Max.	252	1.15

Connections: See section [Pipe connection](#), page 110.
 System pressure: Max. 1.0 MPa (10 bar).
 Liquid temperature: -10 to 110 °C (TF 110).
 Also available with: Stainless-steel pump housing, type N.
 Specific EEI: 0.20.

The pump incorporates overload protection.

Net weight [kg]	Gross weight [kg]	Ship. vol. [m³]
17.7	19.8	0.046

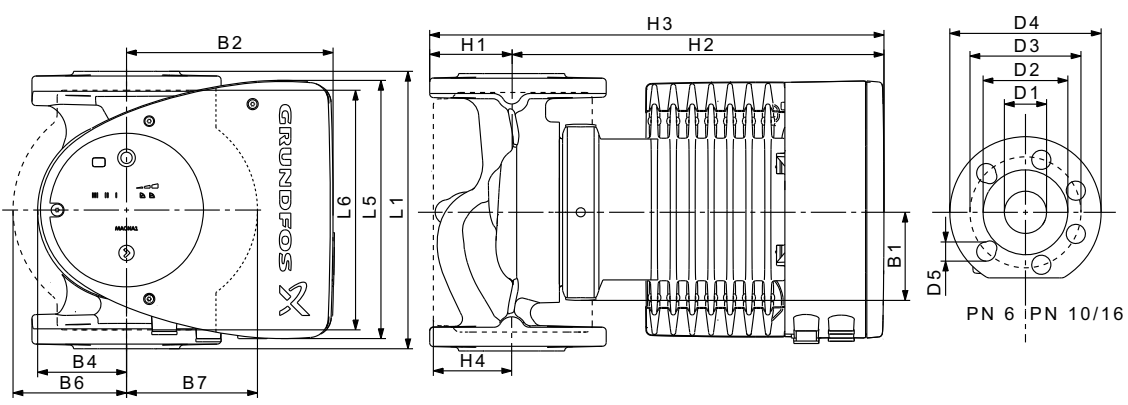

TM05 5276 3512

Pump type	Dimensions [mm]																
	L1	L5	L6	B1	B2	B4	B6	B7	H1	H2	H3	H4	D1	D2	D3	D4	D5
MAGNA1 50-60 F (N)	240	204	240	84	164	73	127	127	71	304	375	97	50	102	110/125	165	14/19

For product numbers, see page 115.

MAGNA1 D 50-60 F PN 10

1 x 230 V, 50/60 Hz

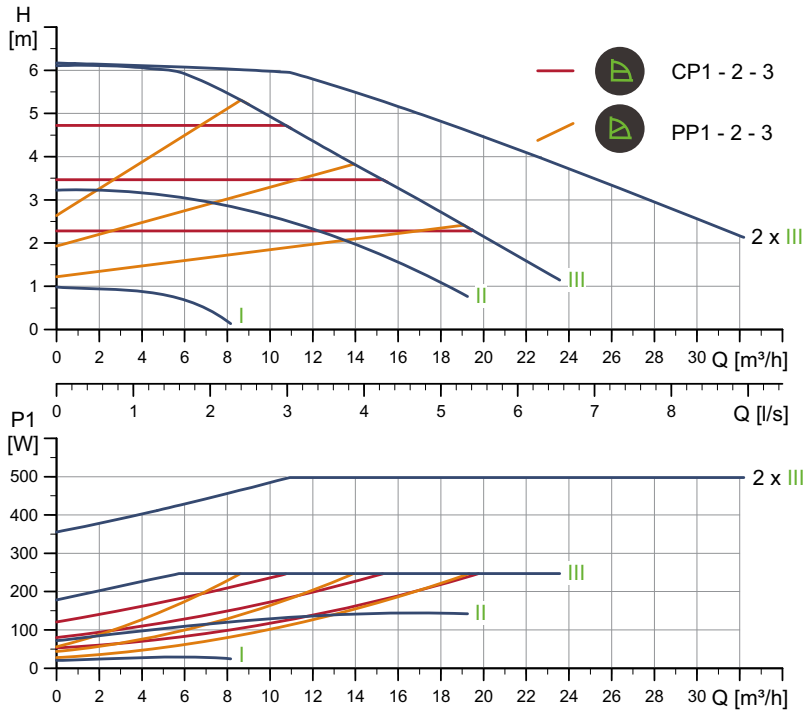

TM05 6341 4817

Speed	P1 [W]	I _{1/1} [A]
Min.	20.9	0.22
Max.	253	1.15

Connections: See section [Pipe connection](#), page 110.
 System pressure: Max. 1.0 MPa (10 bar).
 Liquid temperature: -10 to 110 °C (TF 110).
 Specific EEI: 0.23.

The pump incorporates overload protection.

Net weight [kg]	Gross weight [kg]	Ship. vol. [m ³]
34.3	42.0	0.132

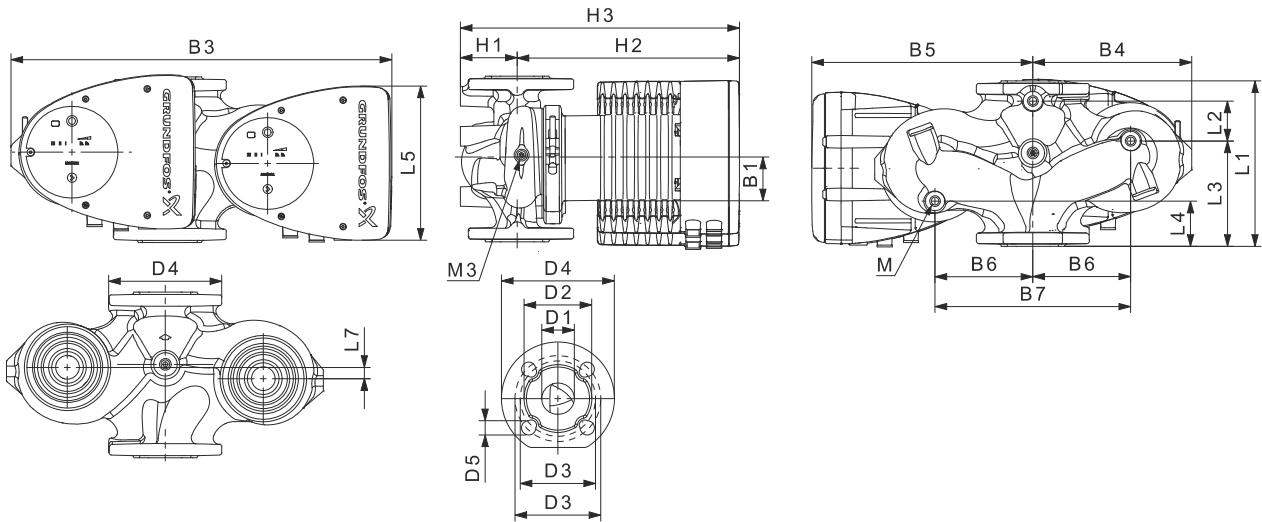

TM05 4960 3012

Pump type	Dimensions [mm]																				Rp	
	L1	L2	L3	L4	L5	L7	B1	B3	B4	B5	B6	B7	H1	H2	H3	D1	D2	D3	D4	D5	M	M3
MAGNA1 D 50-60 F	240	48	160	45	204	45	84	515	221	294	130	260	75	304	379	50	102	110/125	165	14/19	12	1/4

For product numbers, see page 115.

MAGNA1 50-80 F (N) PN 10

1 x 230 V, 50/60 Hz

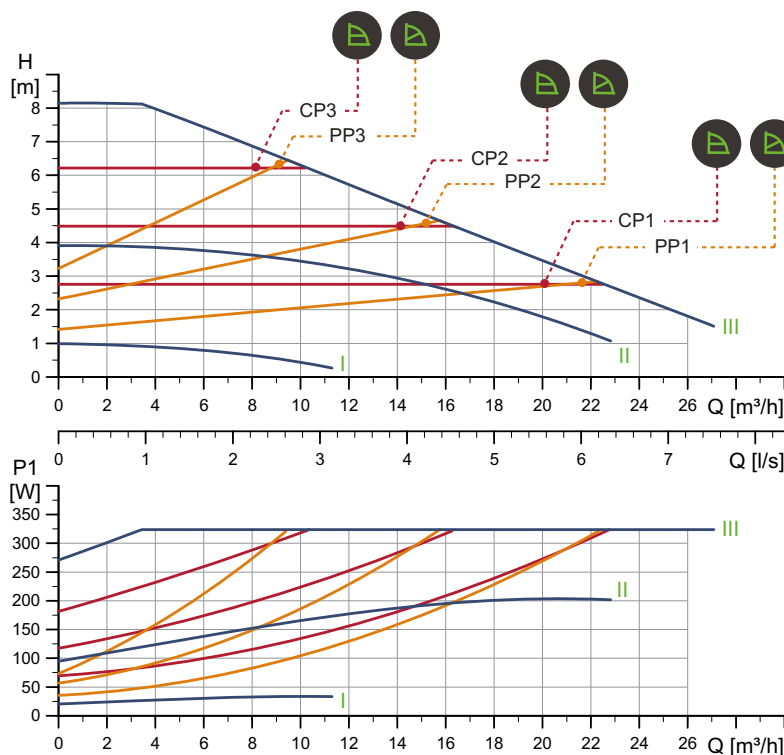

Speed	P1 [W]	I _{1/1} [A]
Min.	20.9	0.22
Max.	331	1.48

The pump incorporates overload protection.

Net weight [kg]	Gross weight [kg]	Ship. vol. [m ³]
17.7	19.8	0.046

Connections: See section [Pipe connection](#), page 110.
 System pressure: Max. 1.0 MPa (10 bar).
 Liquid temperature: -10 to 110 °C (TF 110).
 Also available with: Stainless-steel pump housing, type N.
 Specific EEI: 0.20.

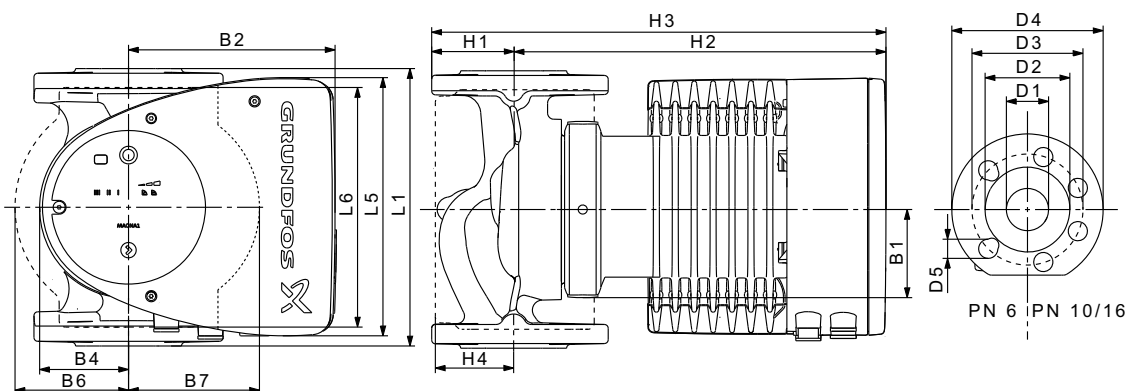

Pump type	Dimensions [mm]																
	L1	L5	L6	B1	B2	B4	B6	B7	H1	H2	H3	H4	D1	D2	D3	D4	D5
MAGNA1 50-80 F (N)	240	204	240	84	164	73	127	127	71	304	374	97	50	102	110/125	165	14/19

For product numbers, see page 115.

TM05 6295 4712

TM05 5276 3512

MAGNA1 D 50-80 F PN 10

1 x 230 V, 50/60 Hz

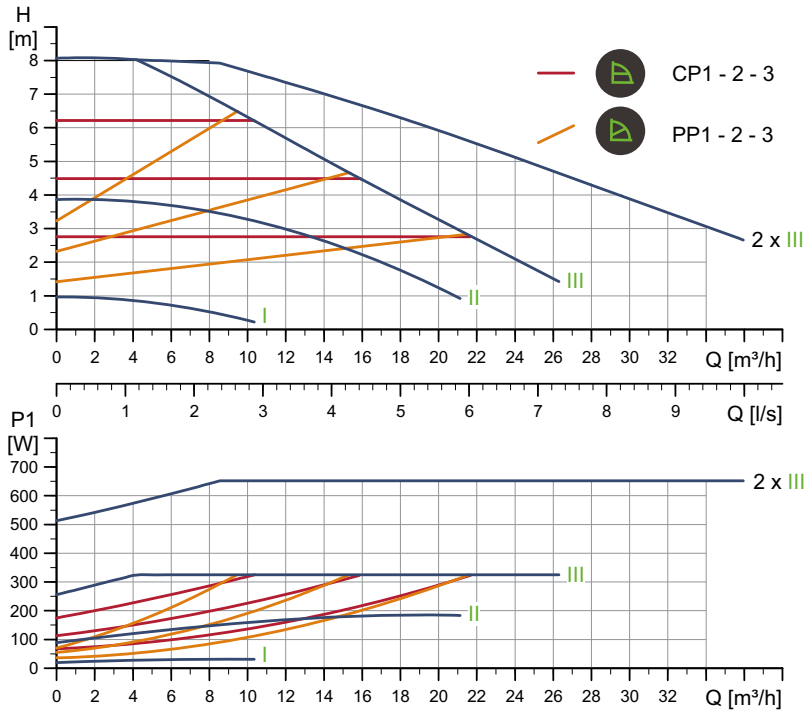

Speed	P1 [W]	I _{1/1} [A]
Min.	20.6	0.22
Max.	331	1.48

Connections: See section [Pipe connection](#), page 110.
 System pressure: Max. 1.0 MPa (10 bar).
 Liquid temperature: -10 to 110 °C (TF 110).
 Specific EEI: 0.22.

The pump incorporates overload protection.

Net weight [kg]	Gross weight [kg]	Ship. vol. [m³]
34.3	42.0	0.132

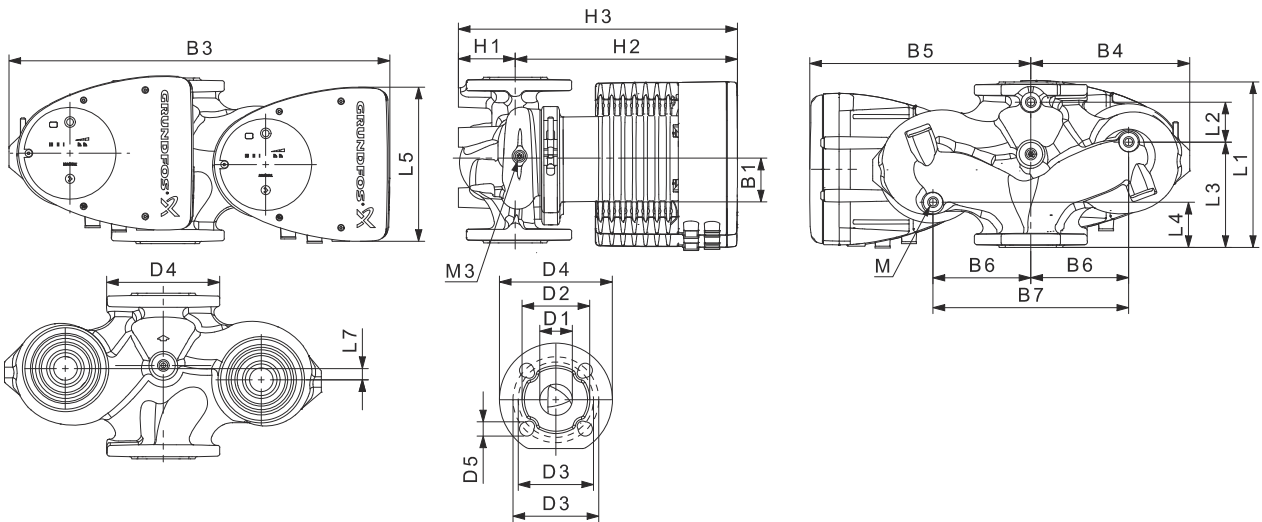

Pump type	Dimensions [mm]																				Rp	
	L1	L2	L3	L4	L5	L7	B1	B3	B4	B5	B6	B7	H1	H2	H3	D1	D2	D3	D4	D5		M
MAGNA1 D 50-80 F	240	48	160	45	204	45	84	515	221	294	130	260	75	304	379	50	102	110/125	165	14/19	12	1/4

For product numbers, see page 115.

TM05 6342 4712

TM05 5937 3613

MAGNA1 50-100 F (N) PN 10

1 x 230 V, 50/60 Hz

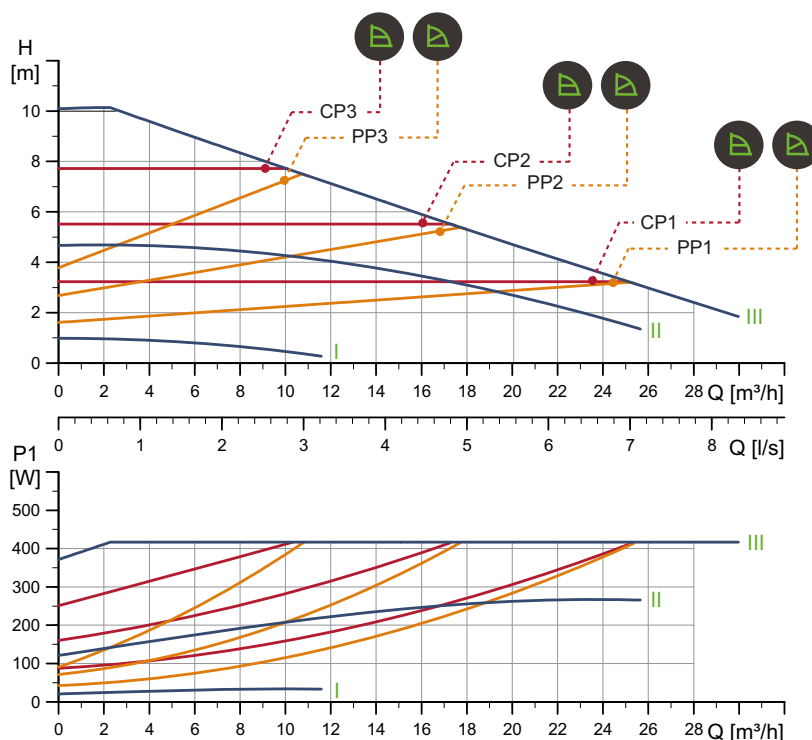

Speed	P1 [W]	I _{1/1} [A]
Min.	20.9	0.22
Max.	425	1.90

The pump incorporates overload protection.

Net weight [kg]	Gross weight [kg]	Ship. vol. [m³]
18.2	20.4	0.046

Connections: See section [Pipe connection](#), page 110.
 System pressure: Max. 1.0 MPa (10 bar).
 Liquid temperature: -10 to 110 °C (TF 110).
 Also available with: Stainless-steel pump housing, type N.
 Specific EEI: 0.20.

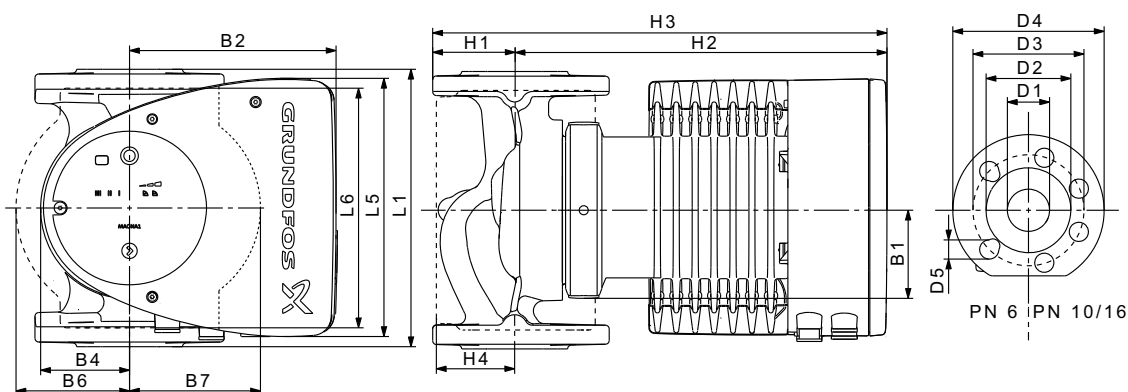

Pump type	Dimensions [mm]																
	L1	L5	L6	B1	B2	B4	B6	B7	H1	H2	H3	H4	D1	D2	D3	D4	D5
MAGNA1 50-100 F (N)	280	204	240	84	164	73	127	127	72	304	376	97	50	102	110/125	165	14/19

For product numbers, see page 115.

TM05 6296 4712

TM05 6276 3512

MAGNA1 D 50-100 F PN 10

1 x 230 V, 50/60 Hz

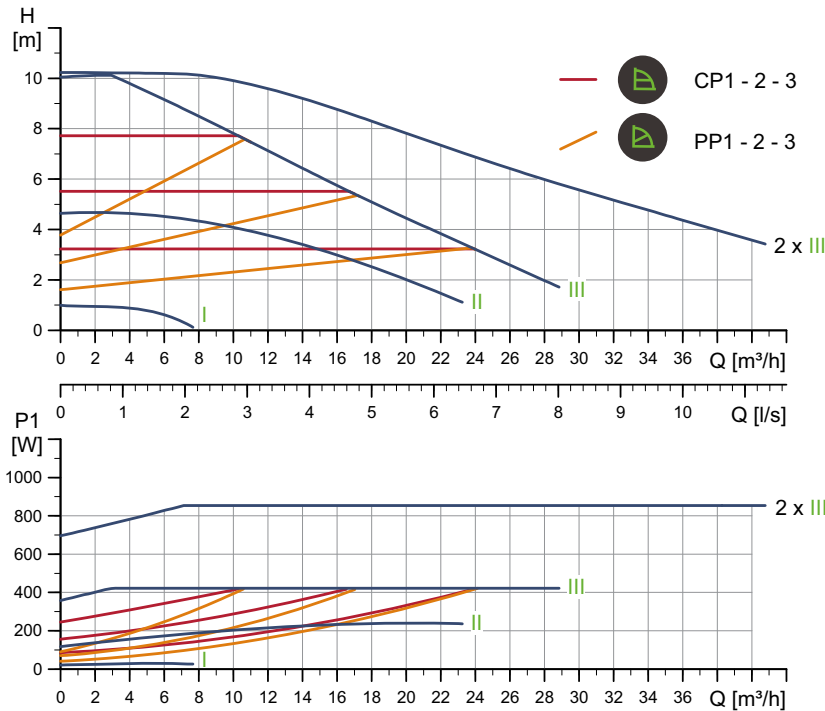

Speed	P1 [W]	I _{1/1} [A]
Min.	21	0.22
Max.	433	1.93

Connections: See section [Pipe connection](#), page 110.
 System pressure: Max. 1.0 MPa (10 bar).
 Liquid temperature: -10 to 110 °C (TF 110).
 Specific EEI: 0.22.

The pump incorporates overload protection.

Net weight [kg]	Gross weight [kg]	Ship. vol. [m ³]
34.3	42.0	0.132

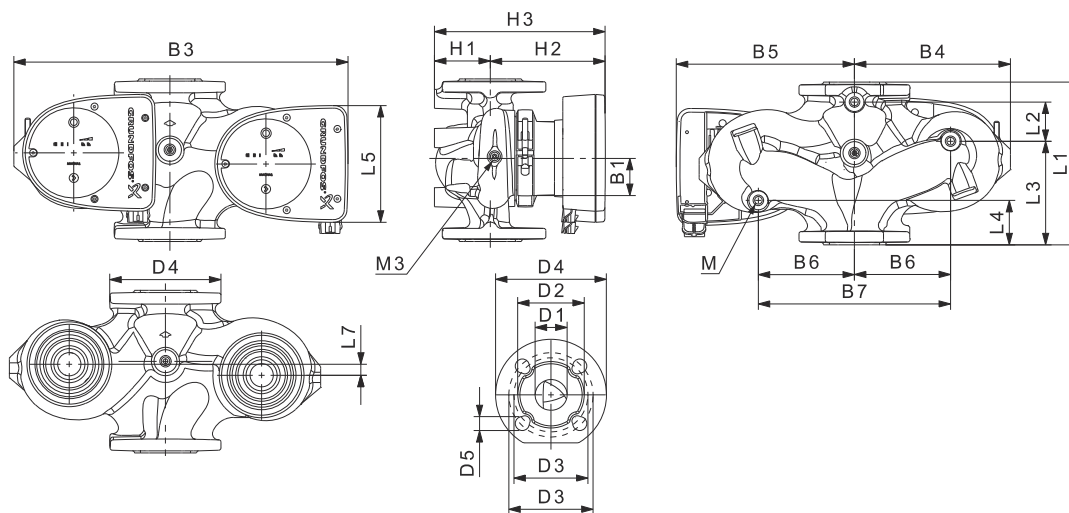

Pump type	Dimensions [mm]																				Rp	
	L1	L2	L3	L4	L5	L7	B1	B3	B4	B5	B6	B7	H1	H2	H3	D1	D2	D3	D4	D5	M	M3
MAGNA1 D 50-100 F	280	175	75	75	204	0	84	517	223	294	130	260	75	304	379	50	102	110/125	165	14/19	12	1/4

For product numbers, see page 115.

TM05 6343 4712

TM05 4960 3012

MAGNA1 50-120 F (N) PN 10

1 x 230 V, 50/60 Hz

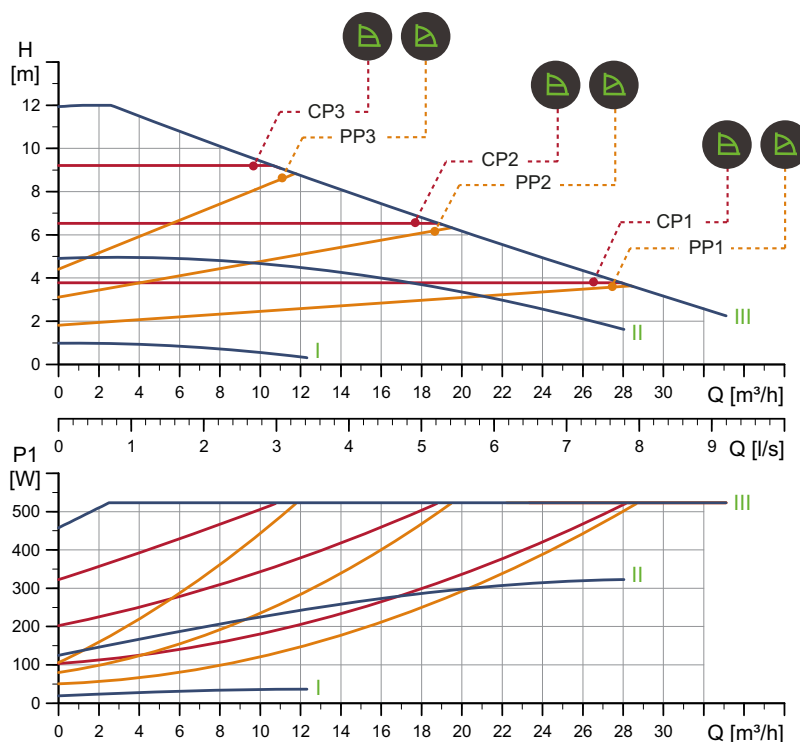

TM05 6297 4712

Speed	P1 [W]	I _{1/1} [A]
Min.	20.2	0.22
Max.	533	2.37

The pump incorporates overload protection.

Connections: See section [Pipe connection](#), page 110.
 System pressure: Max. 1.0 MPa (10 bar).
 Liquid temperature: -10 to 110 °C (TF 110).
 Also available with: Stainless-steel pump housing, type N.
 Specific EEI: 0.20.

Net weight [kg]	Gross weight [kg]	Ship. vol. [m³]
18.2	20.4	0.046

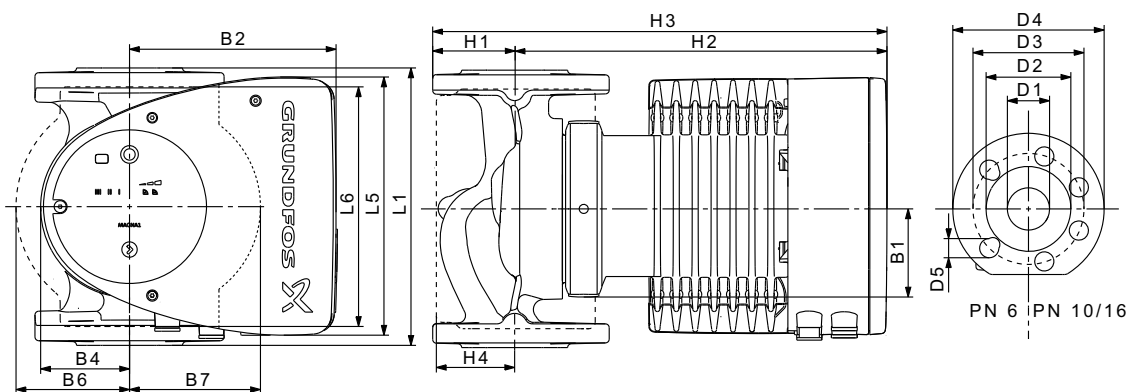

TM05 5276 3512

Pump type	Dimensions [mm]																
	L1	L5	L6	B1	B2	B4	B6	B7	H1	H2	H3	H4	D1	D2	D3	D4	D5
MAGNA1 50-120 F (N)	280	204	240	84	164	73	127	127	72	304	376	97	50	102	110/125	165	14/19

For product numbers, see page 115.

MAGNA1 D 50-120 F PN 10

1 x 230 V, 50/60 Hz

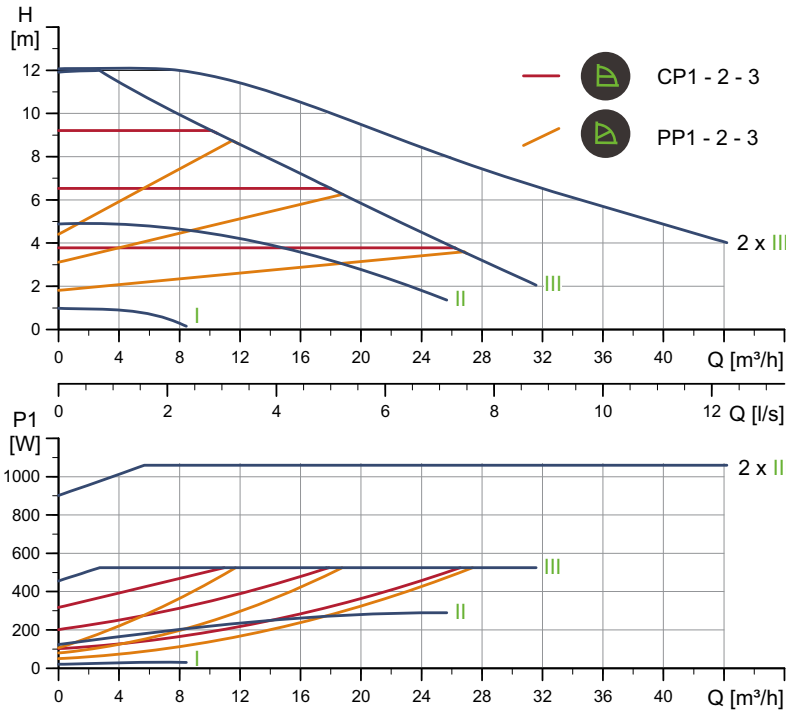

Speed	P1 [W]	I _{1/1} [A]
Min.	20.7	0.22
Max.	534	2.37

Connections: See section [Pipe connection](#), page 110.
 System pressure: Max. 1.0 MPa (10 bar).
 Liquid temperature: -10 to 110 °C (TF 110).
 Specific EEI: 0.22.

The pump incorporates overload protection.

Net weight [kg]	Gross weight [kg]	Ship. vol. [m ³]
34.3	42.0	0.132

TM05 6344 4712

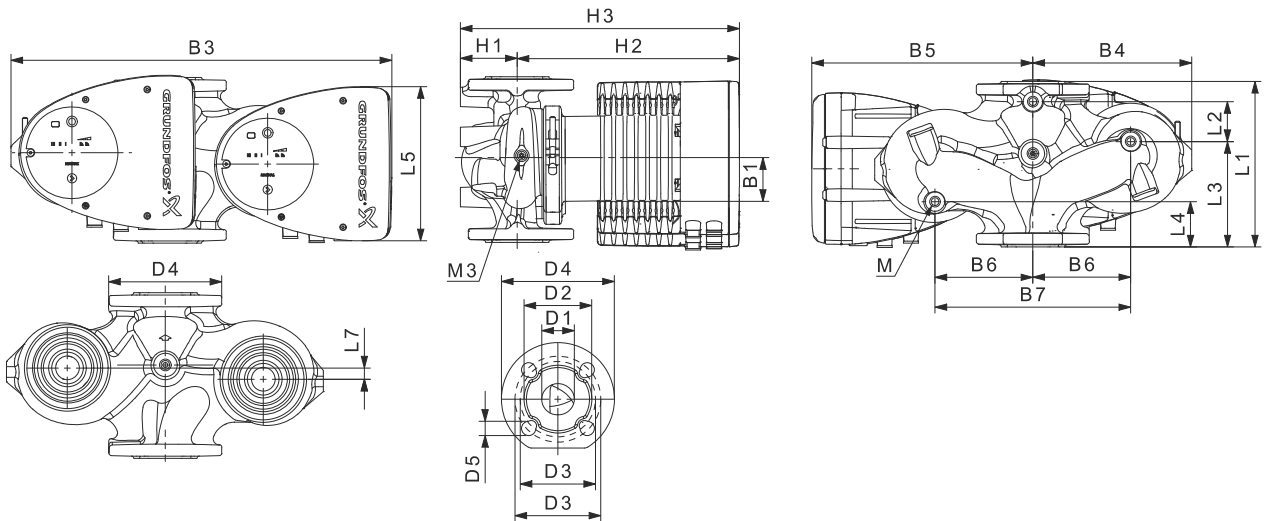

TM05 5937 3613

Pump type	Dimensions [mm]																				Rp	
	L1	L2	L3	L4	L5	L7	B1	B3	B4	B5	B6	B7	H1	H2	H3	D1	D2	D3	D4	D5		M
MAGNA1 D 50-120 F	280	175	75	75	204	0	84	517	223	294	130	260	75	304	379	50	102	110/125	165	14/19	12	1/4

For product numbers, see page 115.

MAGNA1 50-150 F (N) PN 10

1 x 230 V, 50/60 Hz

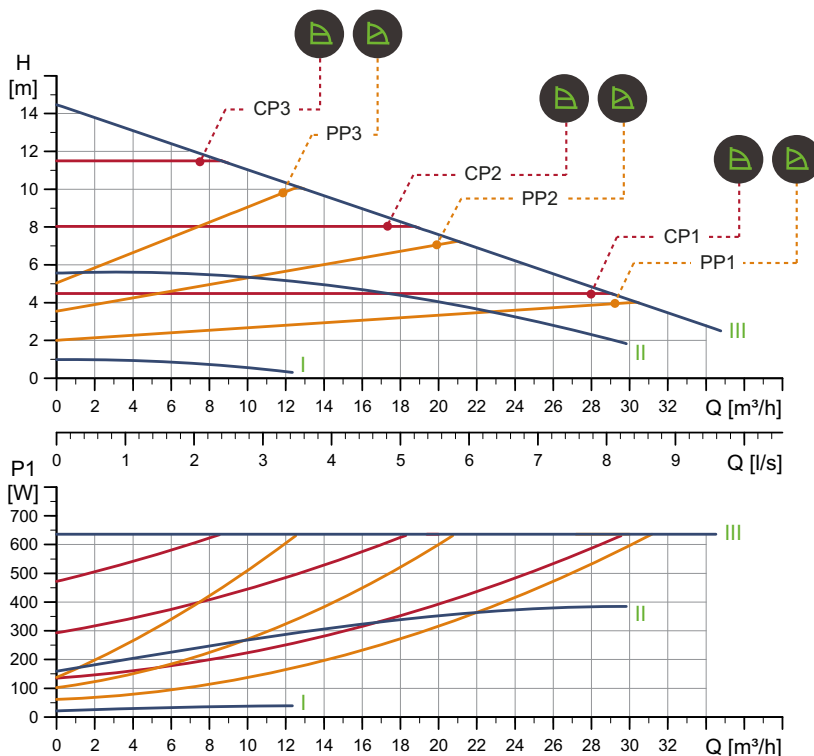

TM05 6298 4712

Speed	P1 [W]	I _{1/1} [A]
Min.	22.2	0.24
Max.	649	2.87

Connections: See section [Pipe connection](#), page 110.
 System pressure: Max. 1.0 MPa (10 bar).
 Liquid temperature: -10 to 110 °C (TF 110).
 Also available with: Stainless-steel pump housing, type N.
 Specific EEI: 0.20.

The pump incorporates overload protection.

Net weight [kg]	Gross weight [kg]	Ship. vol. [m³]
19.1	21.3	0.046

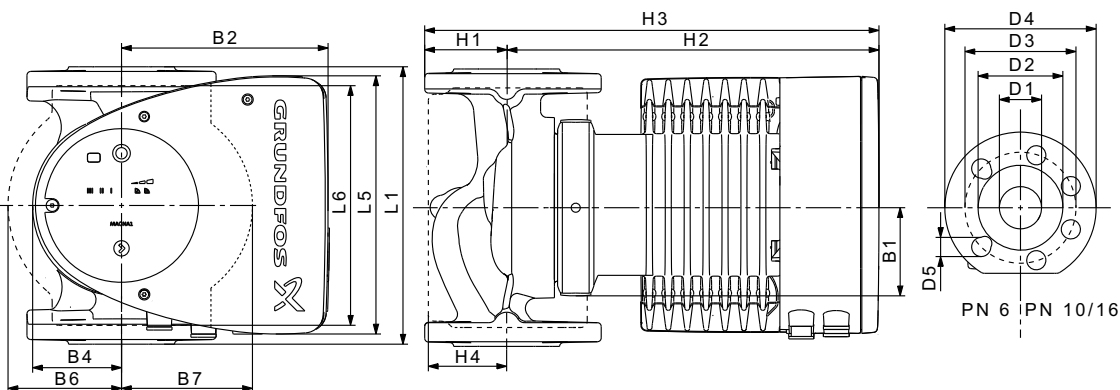

TM05 5200 3412

Pump type	Dimensions [mm]																
	L1	L5	L6	B1	B2	B4	B6	B7	H1	H2	H3	H4	D1	D2	D3	D4	D5
MAGNA1 50-150 F (N)	280	204	240	84	164	73	127	127	72	304	376	97	50	102	110/125	165	14/19

For product numbers, see page 115.

MAGNA1 D 50-150 F PN 10

1 x 230 V, 50/60 Hz

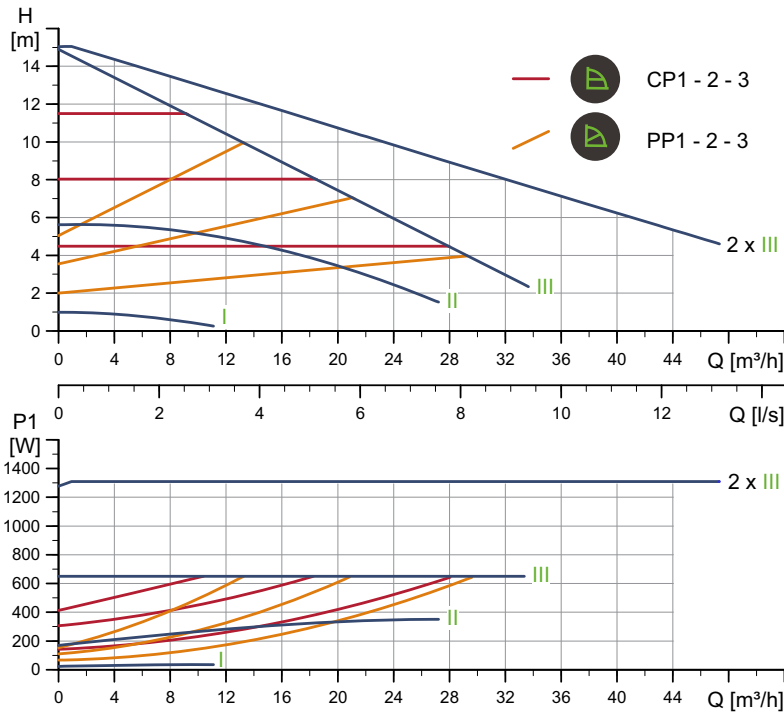

TM05 6345 4712

Speed	P1 [W]	I _{1/1} [A]
Min.	23.8	0.26
Max.	653	2.88

Connections: See section [Pipe connection](#), page 110.
 System pressure: Max. 1.0 MPa (10 bar).
 Liquid temperature: -10 to 110 °C (TF 110).
 Specific EEI: 0.21.

The pump incorporates overload protection.

Net weight [kg]	Gross weight [kg]	Ship. vol. [m ³]
36.1	43.7	0.132

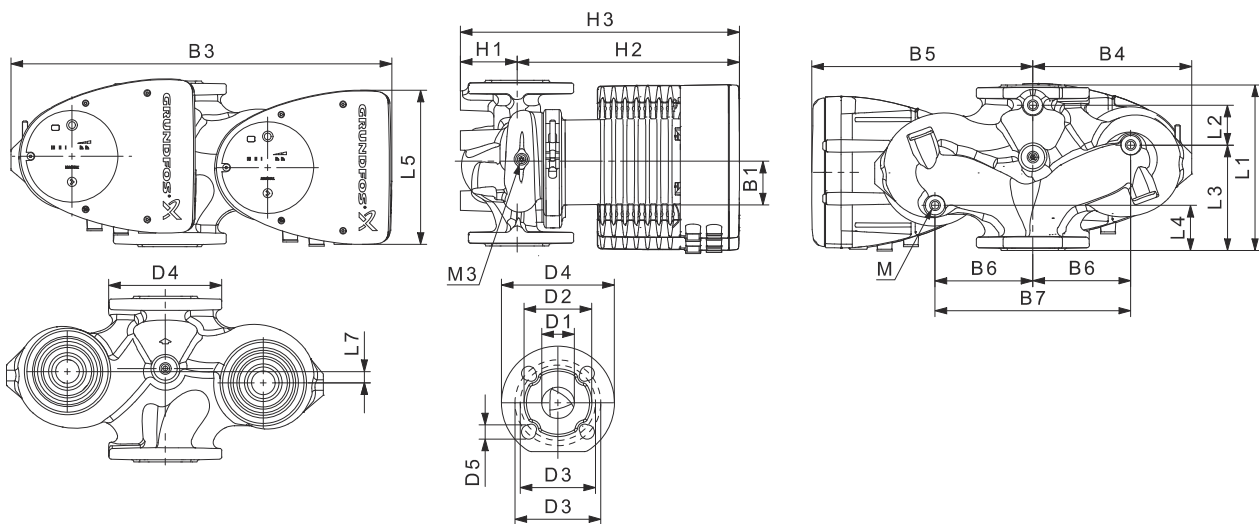

TM05 5837 3613

Pump type	Dimensions [mm]																				Rp	
	L1	L2	L3	L4	L5	L7	B1	B3	B4	B5	B6	B7	H1	H2	H3	D1	D2	D3	D4	D5		M
MAGNA1 D 50-150 F	280	175	75	75	204	0	84	517	223	294	130	260	75	304	379	50	102	110/125	165	14/19	12	1/4

For product numbers, see page 115.

MAGNA1 50-180 F (N) PN 10

1 x 230 V, 50/60 Hz

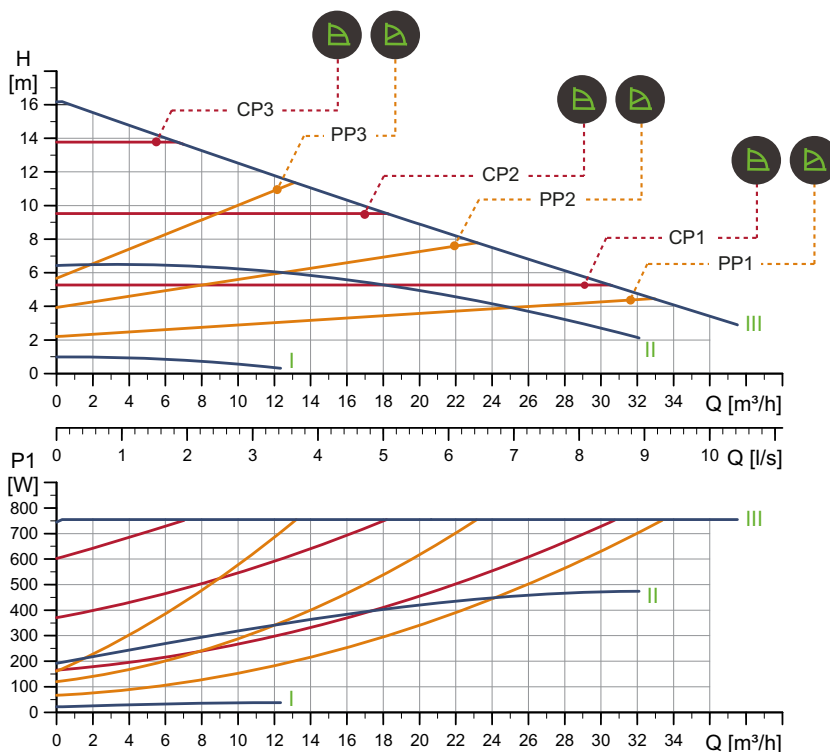

TM05 6299 4712

Speed	P1 [W]	I _{1/1} [A]
Min.	22.1	0.24
Max.	769	3.40

The pump incorporates overload protection.

Connections: See section [Pipe connection](#), page 110.
 System pressure: Max. 1.0 MPa (10 bar).
 Liquid temperature: -10 to 110 °C (TF 110).
 Also available with: Stainless-steel pump housing, type N.
 Specific EEI: 0.20.

Net weight [kg]	Gross weight [kg]	Ship. vol. [m³]
19.1	21.3	0.046

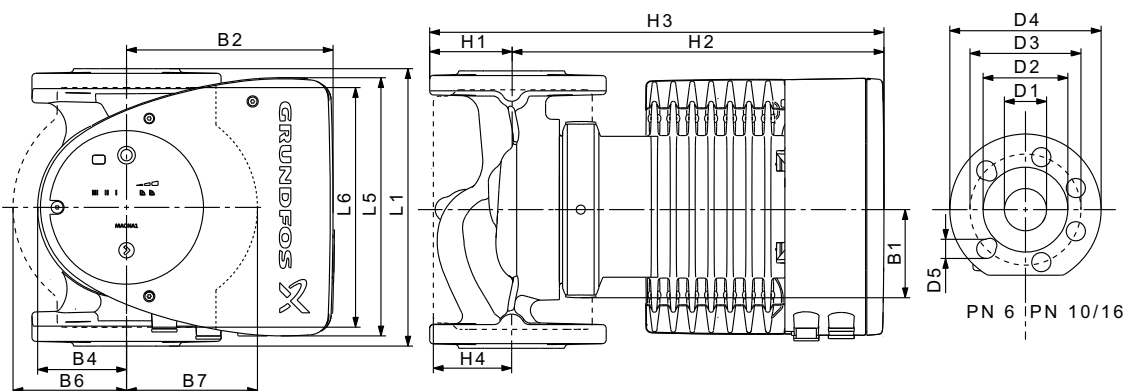

TM05 5276 3512

Pump type	Dimensions [mm]																
	L1	L5	L6	B1	B2	B4	B6	B7	H1	H2	H3	H4	D1	D2	D3	D4	D5
MAGNA1 50-180 F (N)	280	204	240	84	164	73	127	127	72	304	376	97	50	102	110/125	165	14/19

For product numbers, see page 115.

MAGNA1 D 50-180 F PN 10

1 x 230 V, 50/60 Hz

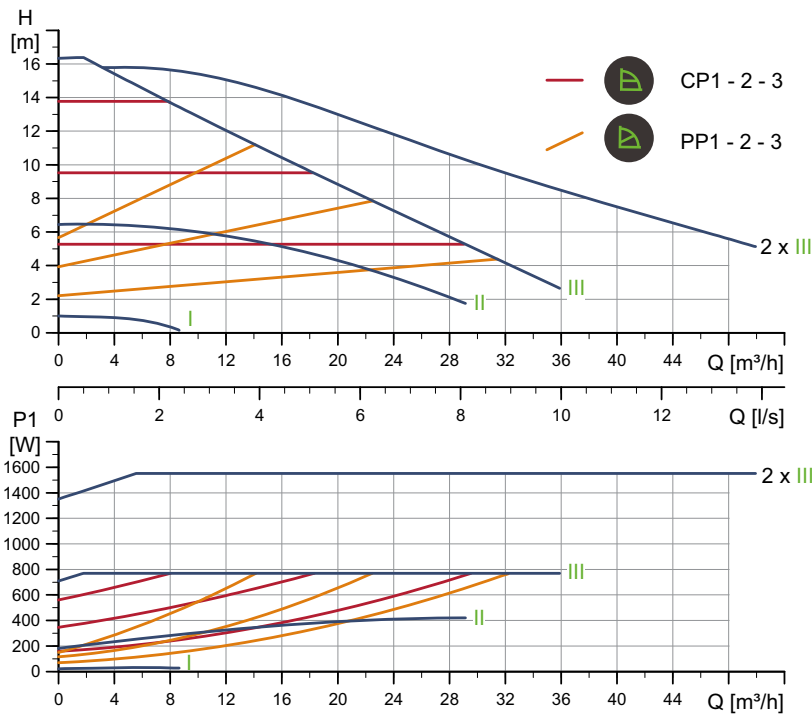

Speed	P1 [W]	I _{1/1} [A]
Min.	22.4	0.23
Max.	785	3.46

Connections: See section [Pipe connection](#), page 110.
 System pressure: Max. 1.0 MPa (10 bar).
 Liquid temperature: -10 to 110 °C (TF 110).
 Specific EEI: 0.22.

The pump incorporates overload protection.

Net weight [kg]	Gross weight [kg]	Ship. vol. [m³]
36.1	43.7	0.132

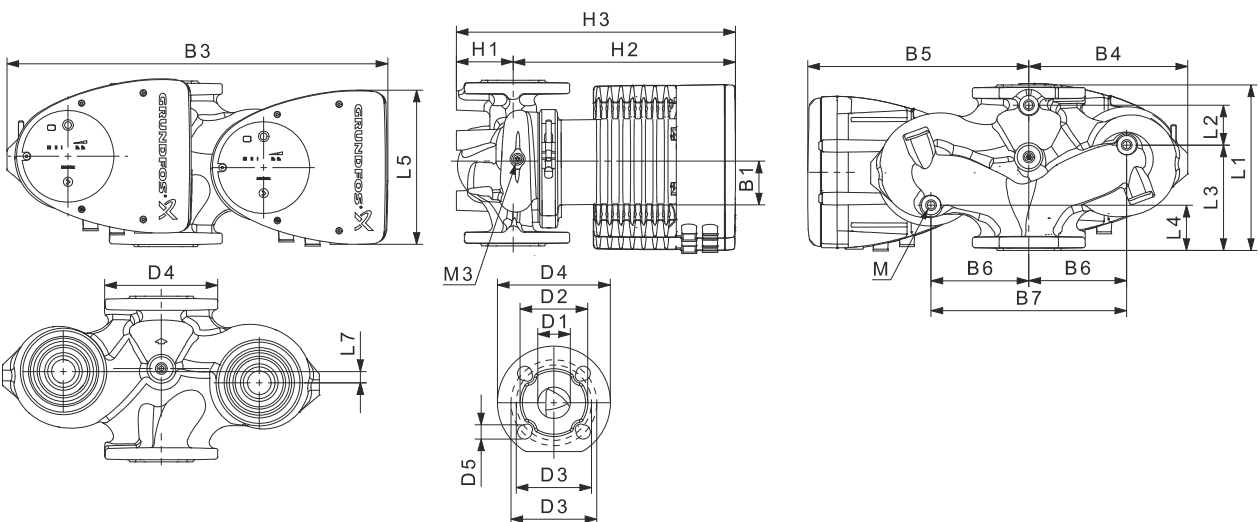

Pump type	Dimensions [mm]																			Rp		
	L1	L2	L3	L4	L5	L7	B1	B3	B4	B5	B6	B7	H1	H2	H3	D1	D2	D3	D4	D5	M	M3
MAGNA1 D 50-180 F	280	175	75	75	204	0	84	517	223	294	130	260	75	304	379	50	102	110/125	165	14/19	12	1/4

For product numbers, see page 115.

TM05 6346 4712

TM05 5937 3613

MAGNA1 65-40 F (N) PN 10

1 x 230 V, 50/60 Hz

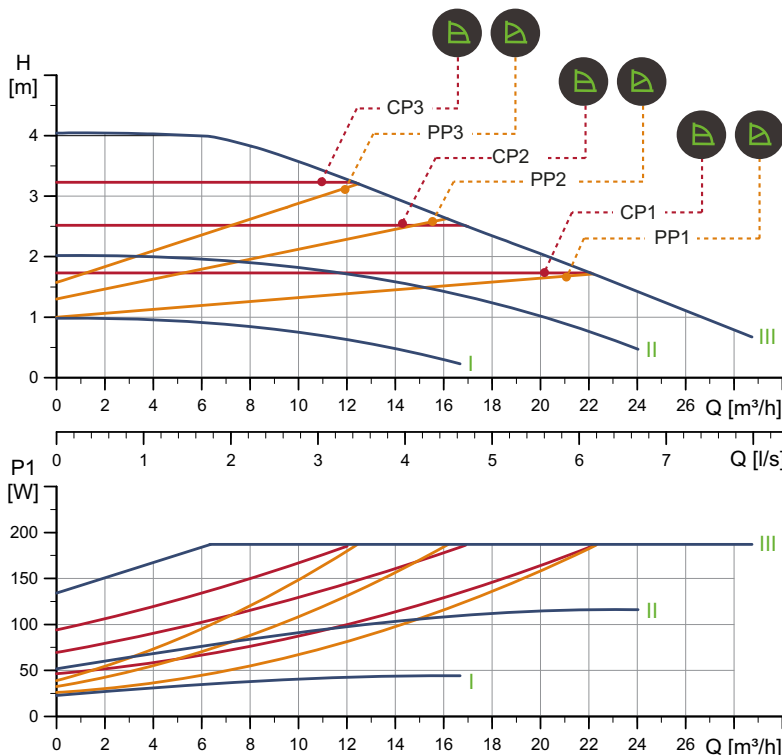

TM05 6300 4712

Speed	P1 [W]	I _{1/1} [A]
Min.	23.2	0.24
Max.	190	0.90

The pump incorporates overload protection.

Connections: See section [Pipe connection](#), page 110.
 System pressure: Max. 1.0 MPa (10 bar).
 Liquid temperature: -10 to 110 °C (TF 110).
 Also available with: Stainless-steel pump housing, type N.
 Specific EEI: 0.20.

Net weight [kg]	Gross weight [kg]	Ship. vol. [m³]
20.7	23.0	0.057

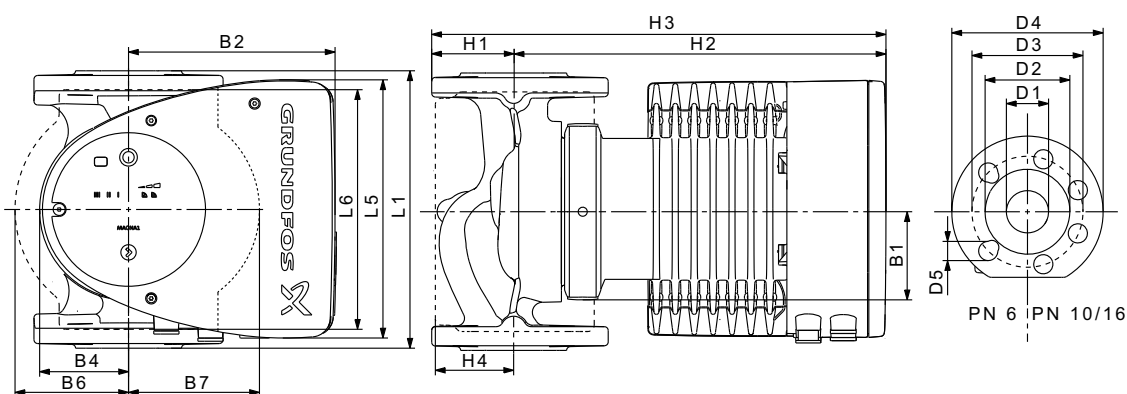

TM05 5276 3512

Pump type	Dimensions [mm]																
	L1	L5	L6	B1	B2	B4	B6	B7	H1	H2	H3	H4	D1	D2	D3	D4	D5
MAGNA1 65-40 F (N)	340	204	296	84	164	73	133	133	74	312	386	94	65	119	130/145	185	14/19

For product numbers, see page 115.

MAGNA1 D 65-40 F PN 10

1 x 230 V, 50/60 Hz

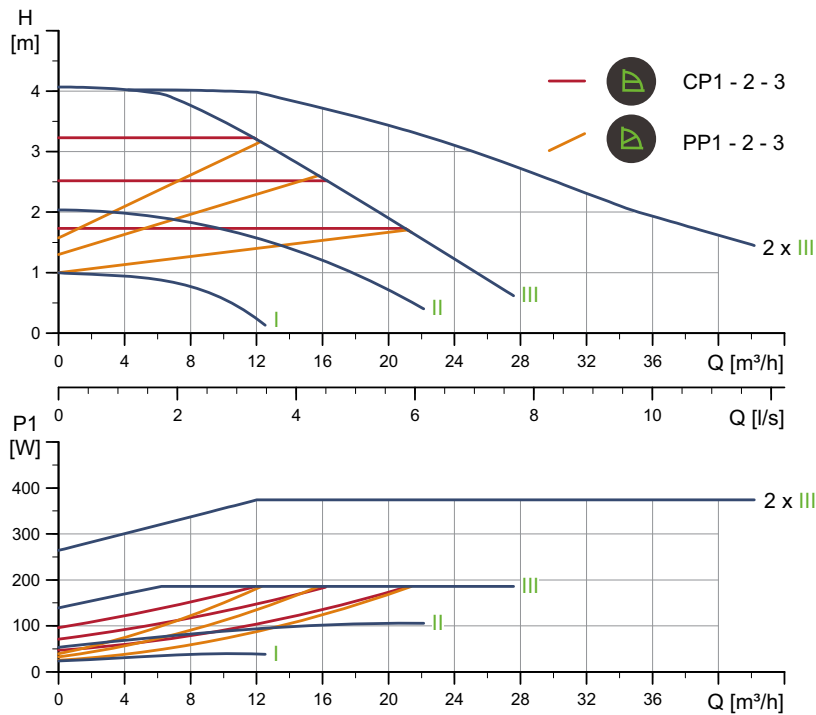

TM05 6347 4712

Speed	P1 [W]	I _{1/1} [A]
Min.	23.9	0.26
Max.	189	0.89

Connections: See section [Pipe connection](#), page 110.
 System pressure: Max. 1.0 MPa (10 bar).
 Liquid temperature: -10 to 110 °C (TF 110).
 Specific EEI: 0.23.

The pump incorporates overload protection.

Net weight [kg]	Gross weight [kg]	Ship. vol. [m ³]
38.5	46.0	0.132

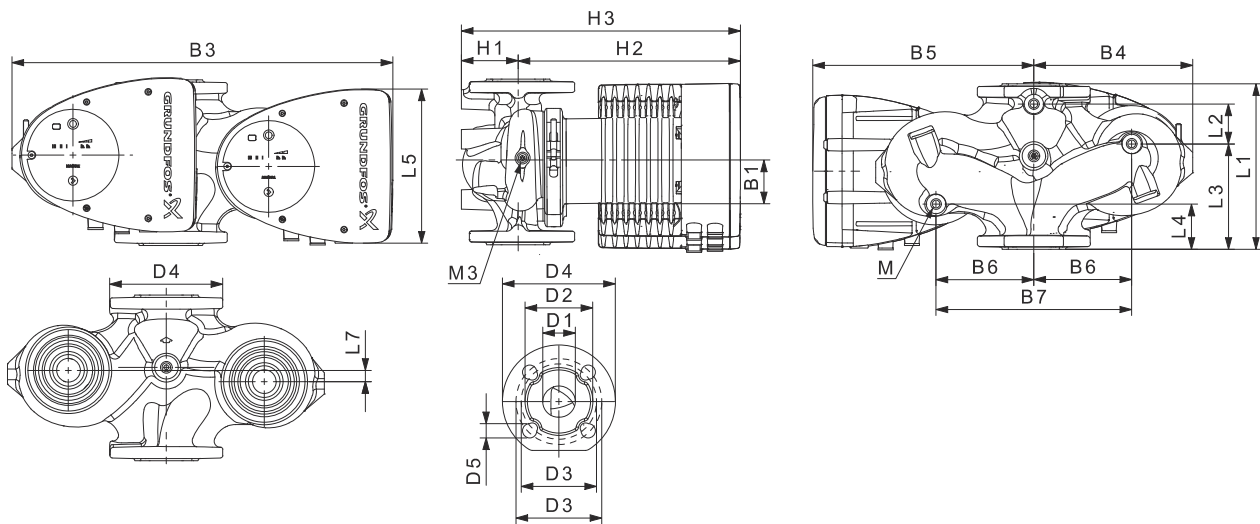

TM05 5937 3613

Pump type	Dimensions [mm]																				Rp	
	L1	L2	L3	L4	L5	L7	B1	B3	B4	B5	B6	B7	H1	H2	H3	D1	D2	D3	D4	D5	M	M3
MAGNA1 D 65-40 F	340	218	92	92	204	0	84	522	228	294	130	260	77	312	389	65	119	130/145	185	14/19	12	1/4

For product numbers, see page 115.

MAGNA1 65-60 F (N) PN 10

1 x 230 V, 50/60 Hz

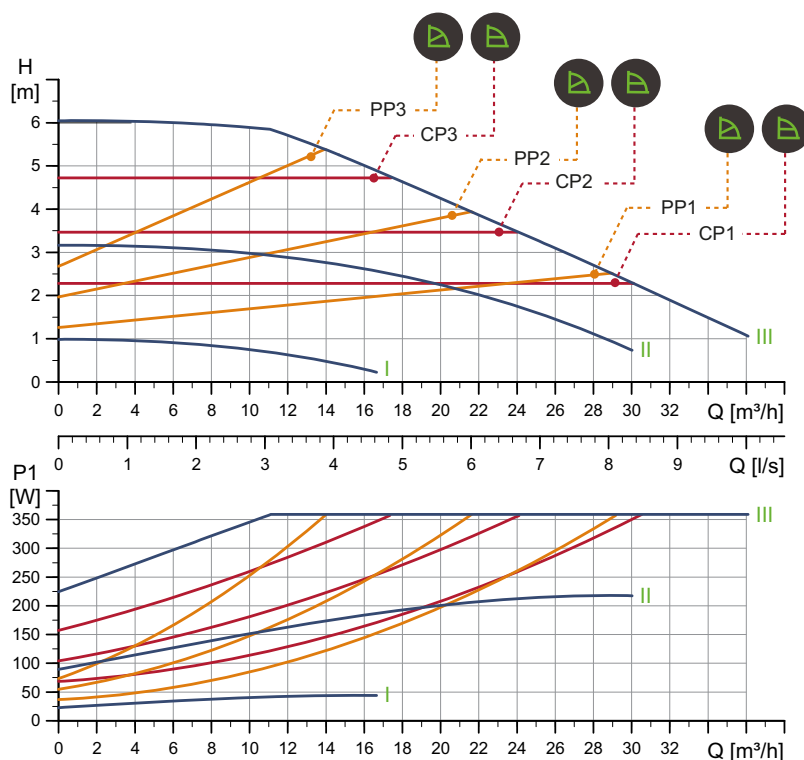

Speed	P1 [W]	I _{1/1} [A]
Min.	23.2	0.24
Max.	365	1.64

The pump incorporates overload protection.

Connections: See section [Pipe connection](#), page 110.
 System pressure: Max. 1.0 MPa (10 bar).
 Liquid temperature: -10 to 110 °C (TF 110).
 Also available with: Stainless-steel pump housing, type N.
 Specific EEI: 0.20

Net weight [kg]	Gross weight [kg]	Ship. vol. [m³]
20.7	23.0	0.057

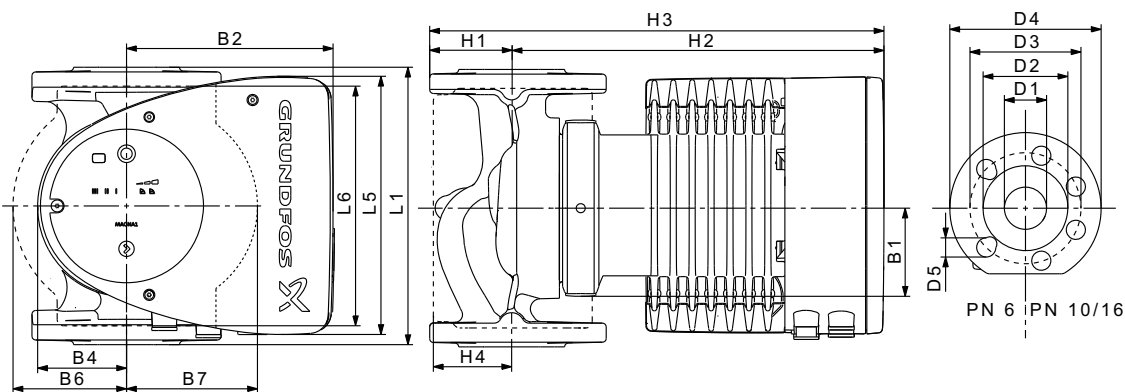

Pump type	Dimensions [mm]																
	L1	L5	L6	B1	B2	B4	B6	B7	H1	H2	H3	H4	D1	D2	D3	D4	D5
MAGNA1 65-60 F (N)	340	204	296	84	164	73	133	133	74	312	386	94	65	119	130/145	185	14/19

For product numbers, see page 115.

TM05 6301 4712

TM05 5276 3512

MAGNA1 D 65-60 F PN 10

1 x 230 V, 50/60 Hz

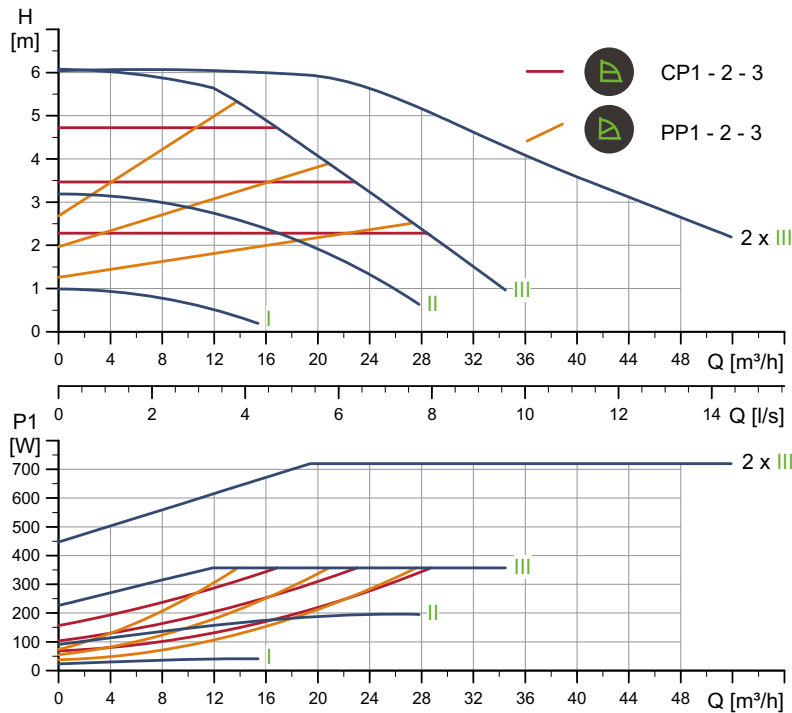

TM05 6348 4712

Speed	P1 [W]	I _{1/1} [A]
Min.	21	0.24
Max.	364	1.63

Connections: See section [Pipe connection](#), page 110.
 System pressure: Max. 1.0 MPa (10 bar).
 Liquid temperature: -10 to 110 °C (TF 110).
 Specific EEI: 0.22.

The pump incorporates overload protection.

Net weight [kg]	Gross weight [kg]	Ship. vol. [m³]
38.5	46.0	0.132

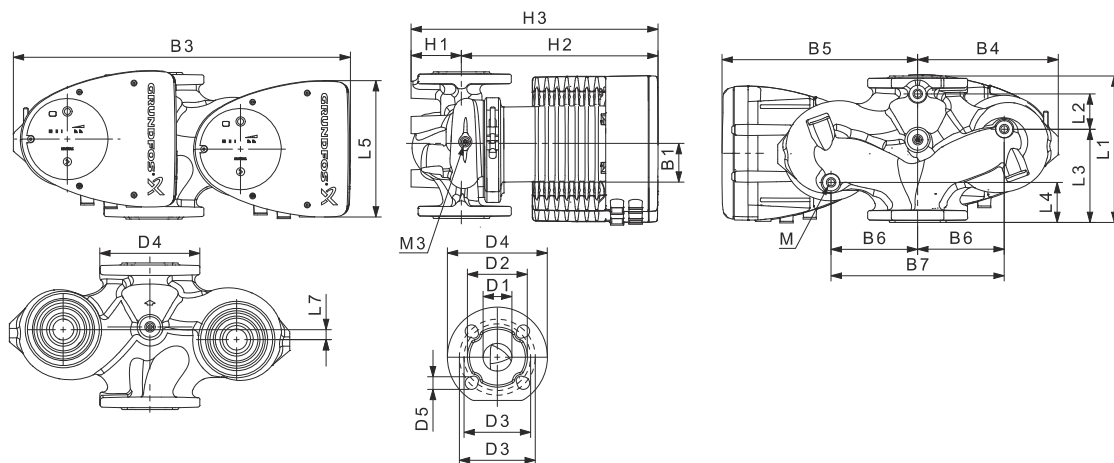

TM05 5937 3613

Pump type	Dimensions [mm]																				Rp	
	L1	L2	L3	L4	L5	L7	B1	B3	B4	B5	B6	B7	H1	H2	H3	D1	D2	D3	D4	D5		M
MAGNA1 D 65-60 F	340	218	92	92	204	0	84	522	228	294	130	260	77	312	389	65	119	130/145	185	14/19	12	1/4

For product numbers, see page 115.

MAGNA1 65-80 F (N) PN 10

1 x 230 V, 50/60 Hz

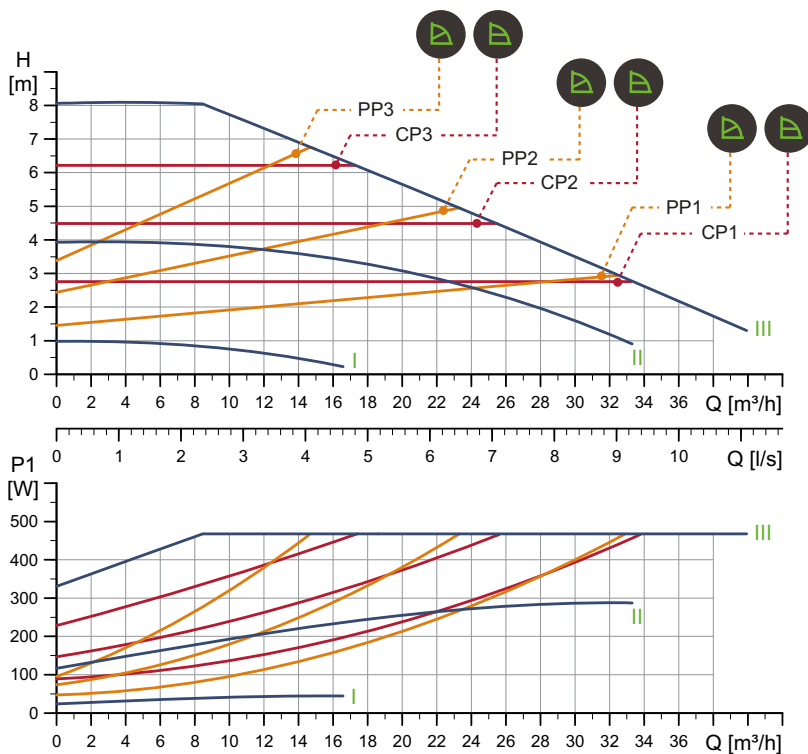

TM05 6302 4712

Speed	P1 [W]	I _{1/1} [A]
Min.	24.2	0.26
Max.	476	2.11

Connections: See section [Pipe connection](#), page 110.
 System pressure: Max. 1.0 MPa (10 bar).
 Liquid temperature: -10 to 110 °C (TF 110).
 Also available with: Stainless-steel pump housing, type N.
 Specific EEI: 0.20.

The pump incorporates overload protection.

Net weight [kg]	Gross weight [kg]	Ship. vol. [m³]
21.6	23.8	0.057

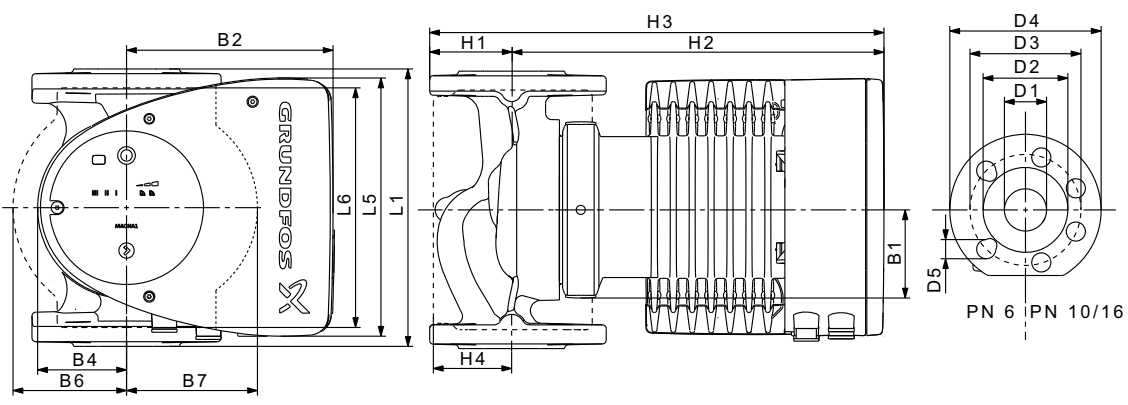

TM05 5276 3512

Pump type	Dimensions [mm]																
	L1	L5	L6	B1	B2	B4	B6	B7	H1	H2	H3	H4	D1	D2	D3	D4	D5
MAGNA1 65-80 F (N)	340	204	296	84	164	73	133	133	74	312	386	94	65	119	130/145	185	14/19

For product numbers, see page 115.

MAGNA1 D 65-80 F PN 10

1 x 230 V, 50/60 Hz

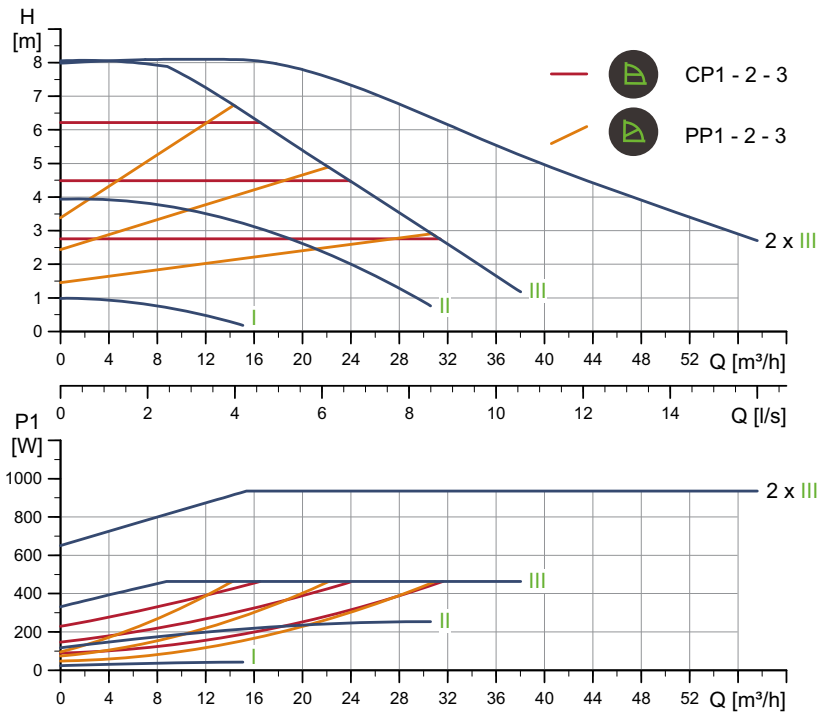

Speed	P1 [W]	I _{1/1} [A]
Min.	24.2	0.26
Max.	472	2.11

Connections: See section [Pipe connection](#), page 110.
 System pressure: Max. 1.0 MPa (10 bar).
 Liquid temperature: -10 to 110 °C (TF 110).
 Specific EEI: 0.21.

The pump incorporates overload protection.

Net weight [kg]	Gross weight [kg]	Ship. vol. [m ³]
40.3	47.8	0.132

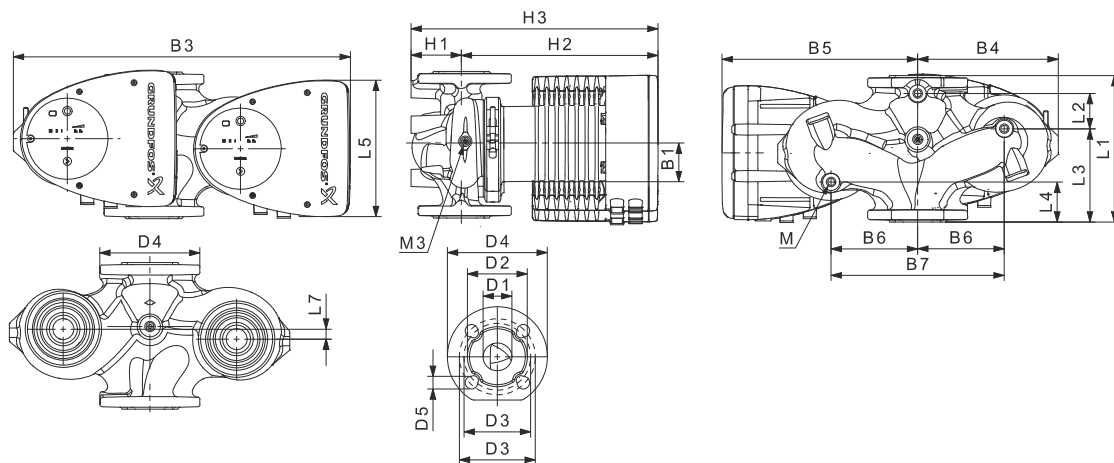

Pump type	Dimensions [mm]																				Rp	
	L1	L2	L3	L4	L5	L7	B1	B3	B4	B5	B6	B7	H1	H2	H3	D1	D2	D3	D4	D5		M
MAGNA1 D 65-80 F	340	218	92	92	204	0	84	522	228	294	130	260	77	312	389	65	119	130/145	185	14/19	12	1/4

For product numbers, see page 115.

TM05 6349 4712

TM05 5937 3613

MAGNA1 65-100 F (N) PN 10

1 x 230 V, 50/60 Hz

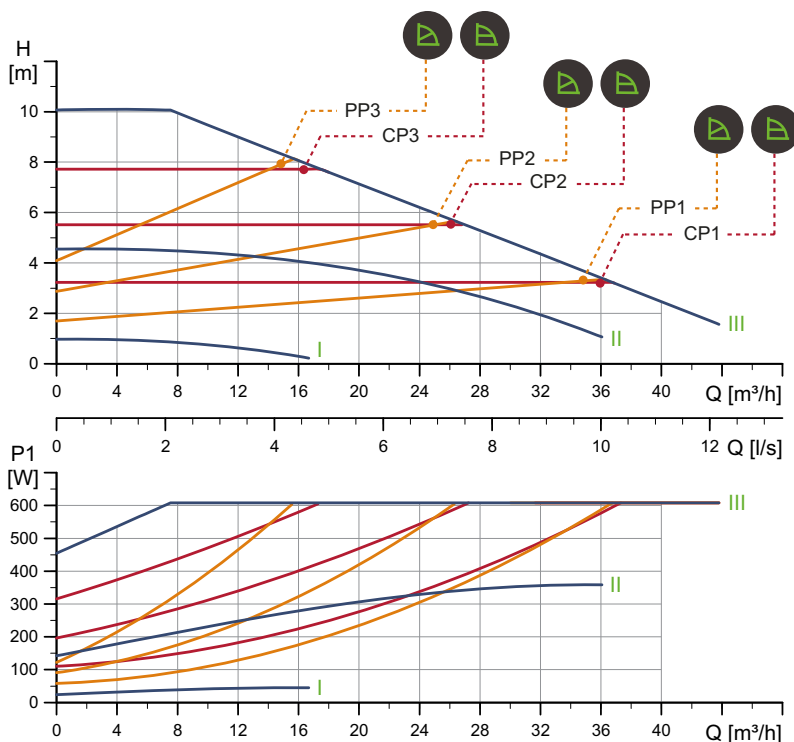

TM05 6303 4712

Speed	P1 [W]	I _{1/1} [A]
Min.	24.7	0.26
Max.	619	2.73

Connections: See section [Pipe connection](#), page 110.
 System pressure: Max. 1.0 MPa (10 bar).
 Liquid temperature: -10 to 110 °C (TF 110).
 Also available with: Stainless-steel pump housing, type N.
 Specific EEI: 0.20.

The pump incorporates overload protection.

Net weight [kg]	Gross weight [kg]	Ship. vol. [m ³]
21.6	23.8	0.057

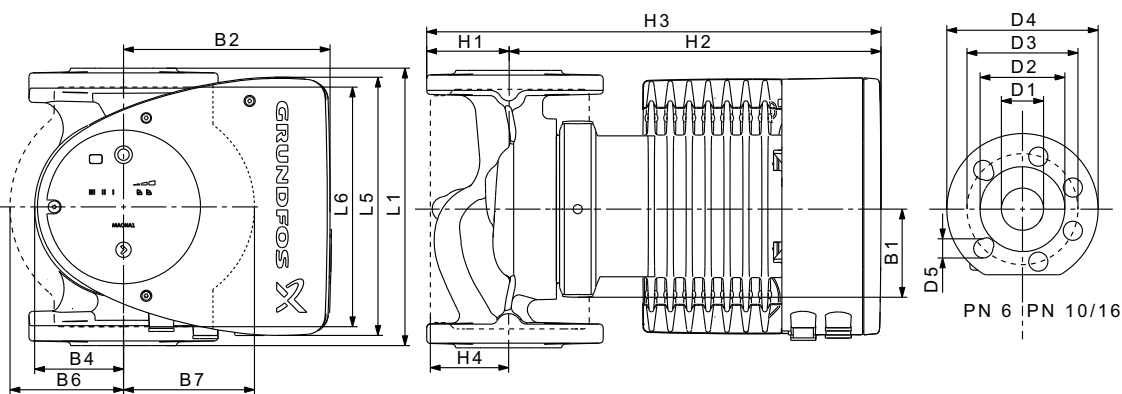

TM05 5276 3512

Pump type	Dimensions [mm]																
	L1	L5	L6	B1	B2	B4	B6	B7	H1	H2	H3	H4	D1	D2	D3	D4	D5
MAGNA1 65-100 F (N)	340	204	296	84	164	73	133	133	74	312	386	94	65	119	130/145	185	14/19

For product numbers, see page 115.

MAGNA1 D 65-100 F PN 10

1 x 230 V, 50/60 Hz

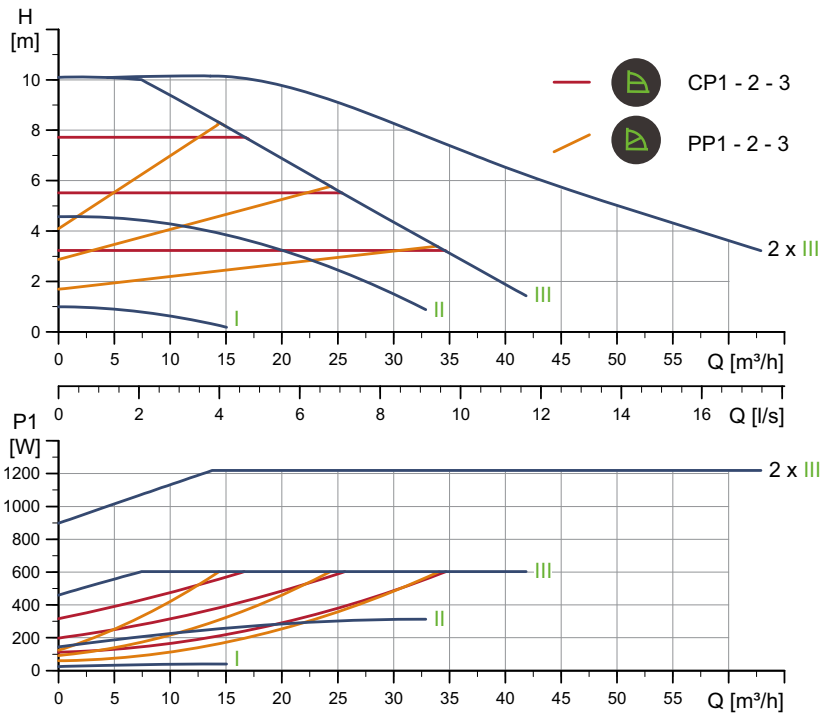

Speed	P1 [W]	I _{1/1} [A]
Min.	24.1	0.26
Max.	614	2.71

Connections: See section [Pipe connection](#), page 110.
 System pressure: Max. 1.0 MPa (10 bar).
 Liquid temperature: -10 to 110 °C (TF 110).
 Specific EEI: 0.21.

The pump incorporates overload protection.

Net weight [kg]	Gross weight [kg]	Ship. vol. [m³]
40.3	47.8	0.132

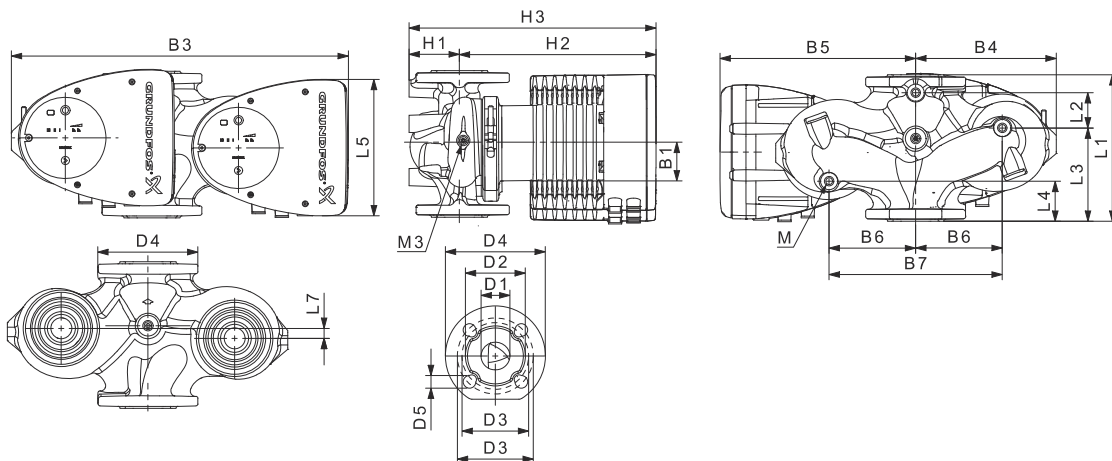

Pump type	Dimensions [mm]																	Rp				
	L1	L2	L3	L4	L5	L7	B1	B3	B4	B5	B6	B7	H1	H2	H3	D1	D2	D3	D4	D5	M	M3
MAGNA1 D 65-100 F	340	218	92	92	204	0	84	522	228	294	130	260	77	312	389	65	119	130/145	185	14/19	12	1/4

For product numbers, see page 115.

TM05 6350 4712

TM05 5937 3613

MAGNA1 65-120 F (N) PN 10

1 x 230 V, 50/60 Hz

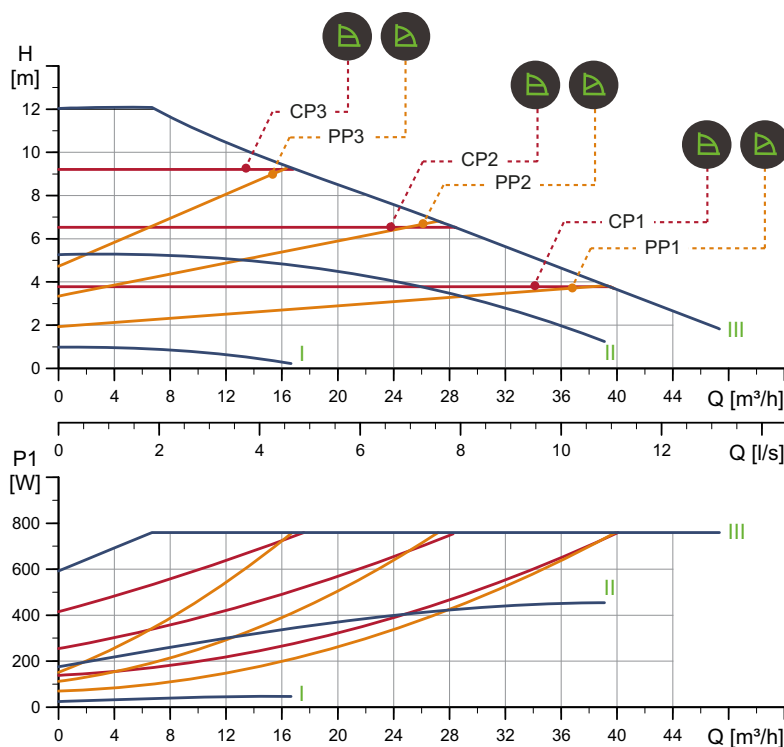

TM05 6304 4712

Speed	P1 [W]	I _{1/1} [A]
Min.	24.38	0.26
Max.	774	3.42

The pump incorporates overload protection.

Connections: See section *Pipe connection*, page 110.
 System pressure: Max. 1.0 MPa (10 bar).
 Liquid temperature: -10 to 110 °C (TF 110).
 Also available with: Stainless-steel pump housing, type N.
 Specific EEI: 0.18.

Net weight [kg]	Gross weight [kg]	Ship. vol. [m³]
21.6	23.8	0.057

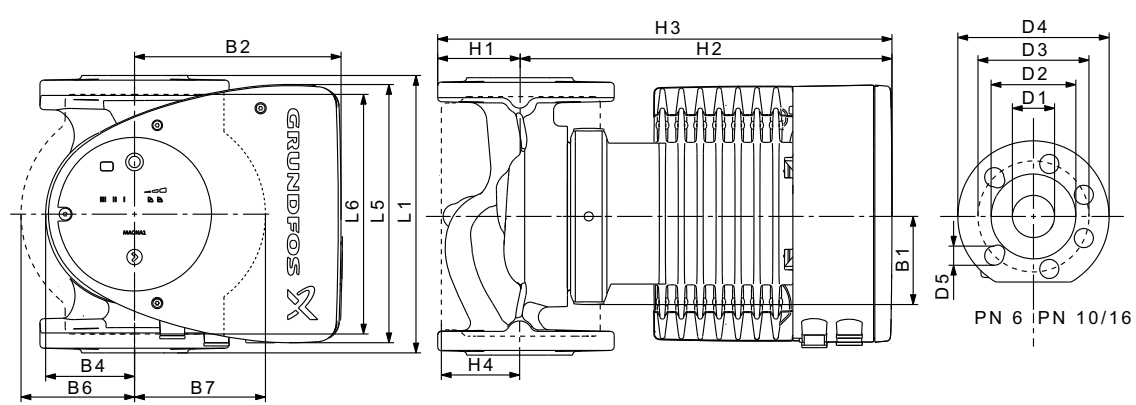

TM05 5276 3512

Pump type	Dimensions [mm]																
	L1	L5	L6	B1	B2	B4	B6	B7	H1	H2	H3	H4	D1	D2	D3	D4	D5
MAGNA1 65-120 F (N)	340	204	296	84	164	73	133	133	74	312	386	94	65	119	130/145	185	14/19

For product numbers, see page 115.

MAGNA1 D 65-120 F PN 10

1 x 230 V, 50/60 Hz

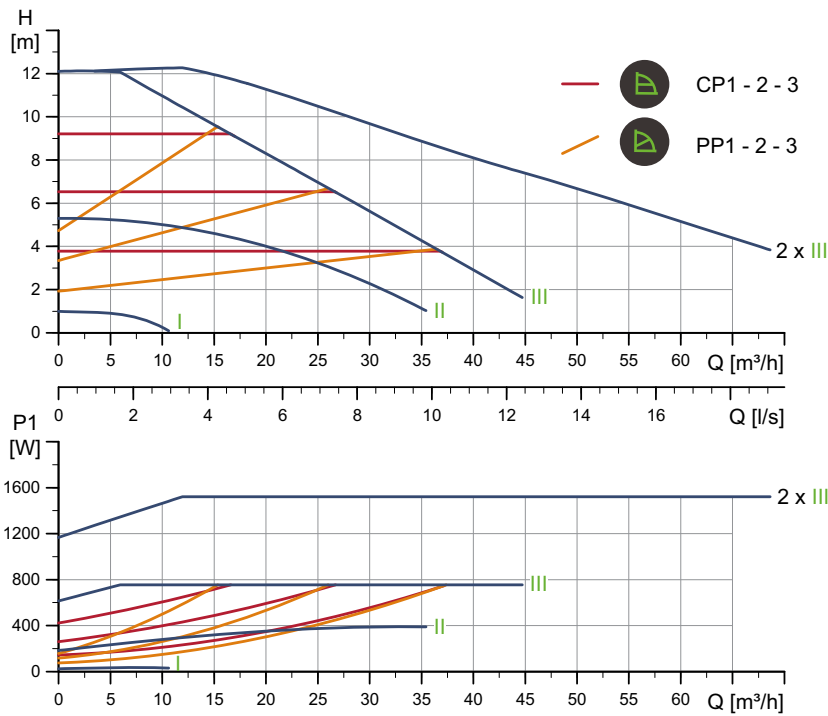

TM05 6351 4712

Speed	P1 [W]	I _{1/1} [A]
Min.	24.9	0.27
Max.	769	3.39

Connections: See section [Pipe connection](#), page 110.
 System pressure: Max. 1.0 MPa (10 bar).
 Liquid temperature: -10 to 110 °C (TF 110).
 Specific EEI: 0.21.

The pump incorporates overload protection.

Net weight [kg]	Gross weight [kg]	Ship. vol. [m³]
40.3	47.8	0.132

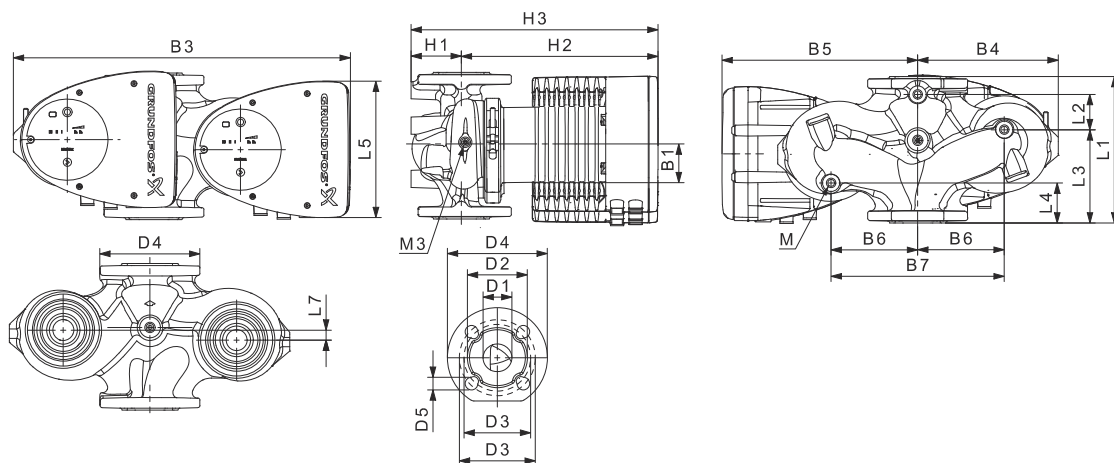

TM05 5937 3613

Pump type	Dimensions [mm]																				Rp	
	L1	L2	L3	L4	L5	L7	B1	B3	B4	B5	B6	B7	H1	H2	H3	D1	D2	D3	D4	D5		M
MAGNA1 D 65-120 F	340	218	92	92	204	0	84	522	228	294	130	260	77	312	389	65	119	130/145	185	14/19	12	1/4

For product numbers, see page 115.

MAGNA1 65-150 F (N) PN 10

1 x 230 V, 50/60 Hz

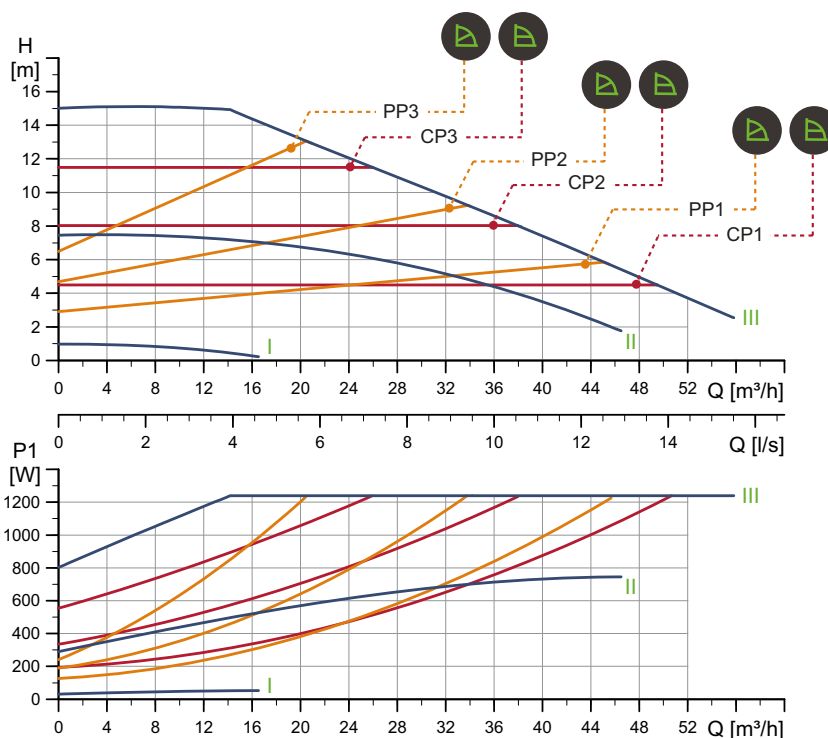

TM05 6305 4712

Speed	P1 [W]	I _{1/1} [A]
Min.	30.7	0.31
Max.	1263	5.53

Connections: See section [Pipe connection](#), page 110.
 System pressure: Max. 1.0 MPa (10 bar).
 Liquid temperature: -10 to 110 °C (TF 110).
 Also available with: Stainless-steel pump housing, type N.
 Specific EEI: 0.18.

The pump incorporates overload protection.

Net weight [kg]	Gross weight [kg]	Ship. vol. [m³]
24.3	26.6	0.057

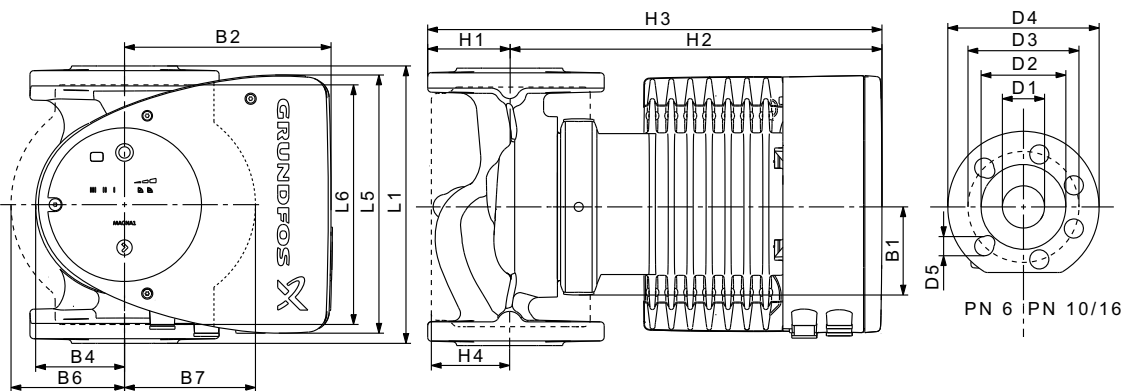

TM05 5276 3512

Pump type	Dimensions [mm]																
	L1	L5	L6	B1	B2	B4	B6	B7	H1	H2	H3	H4	D1	D2	D3	D4	D5
MAGNA1 65-150 F (N)	340	204	296	84	164	73	133	133	74	312	386	94	65	119	130/145	185	14/19

For product numbers, see page 115.

MAGNA1 D 65-150 F PN 10

1 x 230 V, 50/60 Hz

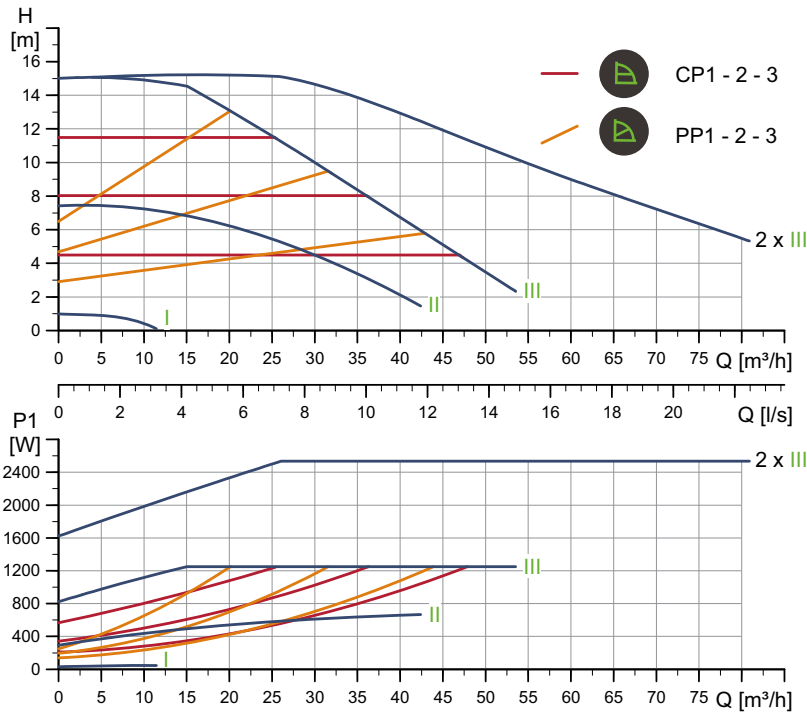

Speed	P1 [W]	I _{1/1} [A]
Min.	32.3	0.33
Max.	1275	5.62

Connections: See section [Pipe connection](#), page 110.
 System pressure: Max. 1.0 MPa (10 bar).
 Liquid temperature: -10 to 110 °C (TF 110).
 Specific EEI: 0.21.

The pump incorporates overload protection.

Net weight [kg]	Gross weight [kg]	Ship. vol. [m ³]
45.7	53.2	0.132

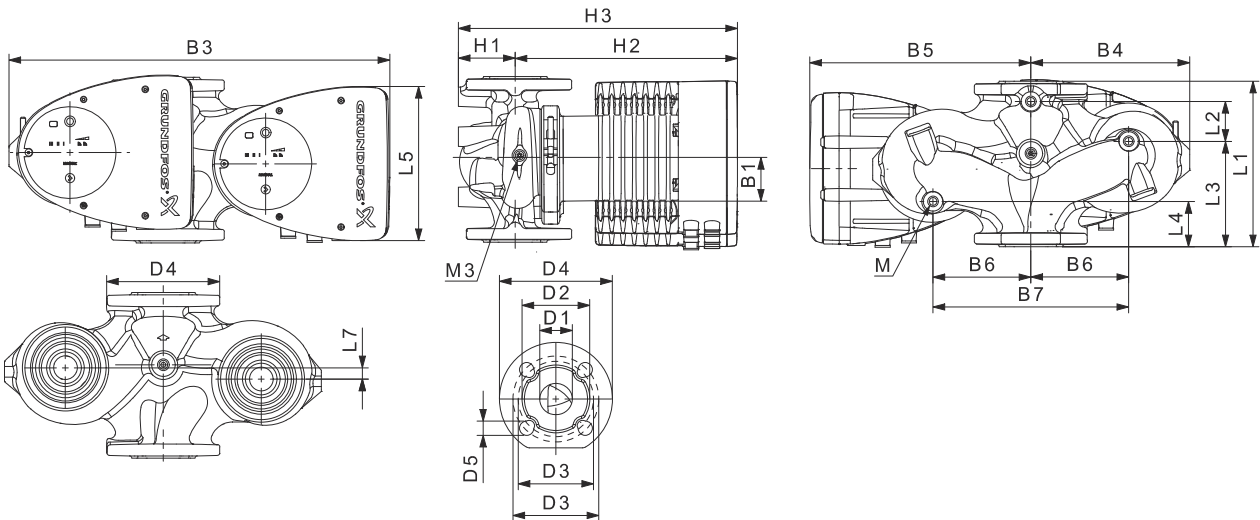

Pump type	Dimensions [mm]																				Rp	
	L1	L2	L3	L4	L5	L7	B1	B3	B4	B5	B6	B7	H1	H2	H3	D1	D2	D3	D4	D5	M	M3
MAGNA1 D 65-150 F	340	218	92	92	204	0	84	522	228	294	130	260	77	312	389	65	119	130/145	185	14/19	12	1/4

For product numbers, see page 115.

TM05 6352 4712

TM05 6937 3613

MAGNA1 D 80-40 F PN 10

1 x 230 V, 50/60 Hz

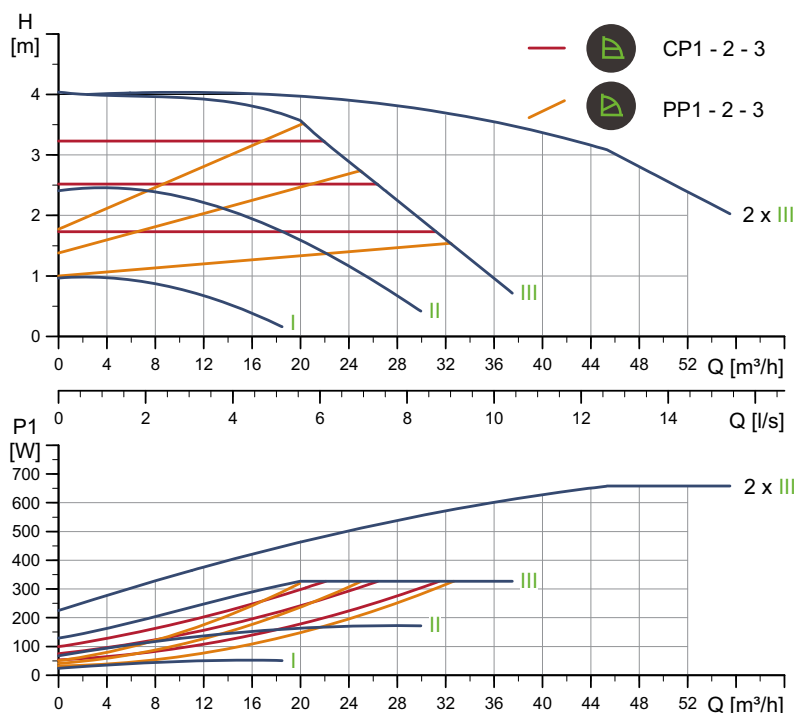

TM05 6353 4712

Speed	P1 [W]	I _{1/1} [A]
Min.	25.3	0.27
Max.	333	1.49

Connections: See section [Pipe connection](#), page 110.
 System pressure: Max. 1.0 MPa (10 bar).
 Liquid temperature: -10 to 110 °C (TF 110).
 Specific EEI: 0.21.

The pump incorporates overload protection.

Net weight [kg]	Gross weight [kg]	Ship. vol. [m³]
45.9	55.7	0.208

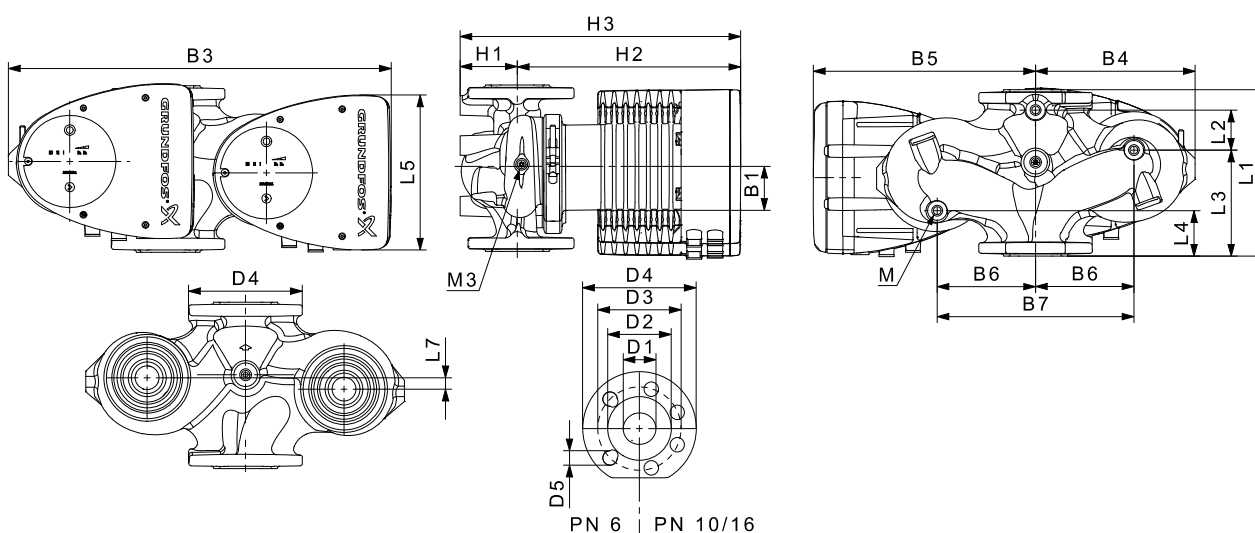

TM05 5275 3512

Pump type	Dimensions [mm]																	Rp				
	L1	L2	L3	L4	L5	L7	B1	B3	B4	B5	B6	B7	H1	H2	H3	D1	D2	D3	D4	D5	M	M3
MAGNA1 D 80-40 F	360	218	102	102	204	0	84	538	244	294	130	260	97	318	415	80	128	150/160	200	19	12	1/4

For product numbers, see page 115.

MAGNA1 80-60 F PN 10

1 x 230 V, 50/60 Hz

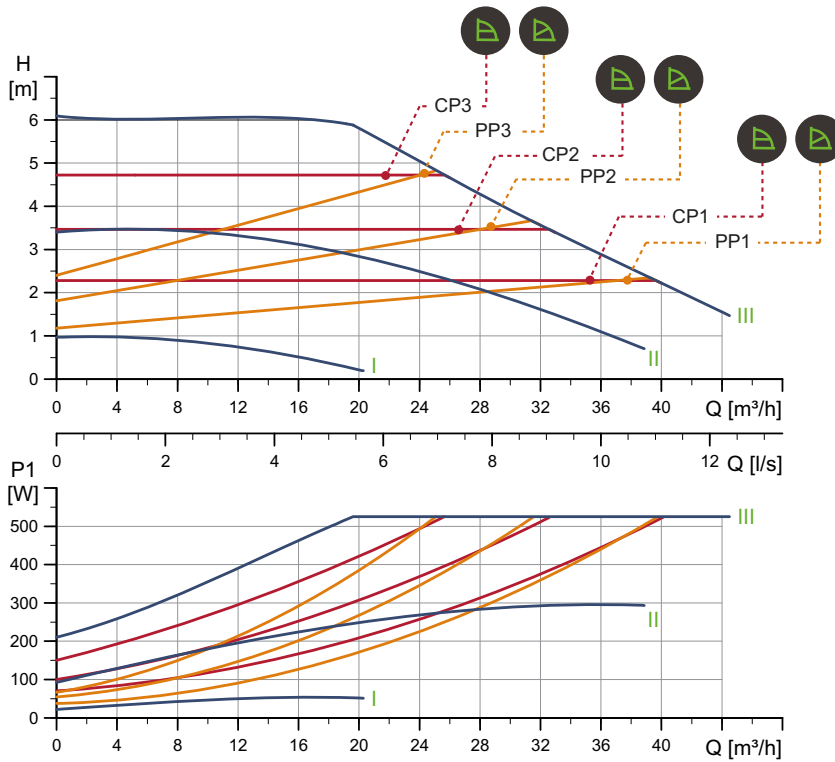

Speed	P1 [W]	$I_{1/1}$ [A]
Min.	23.6	0.24
Max.	536	2.37

Connections: See section [Pipe connection](#), page 110.
 System pressure: Max. 1.0 MPa (10 bar).
 Liquid temperature: -10 to 110 °C (TF 110).
 Specific EEI: 0.20.

The pump incorporates overload protection.

Net weight [kg]	Gross weight [kg]	Ship. vol. [m³]
26.8	29.1	0.072

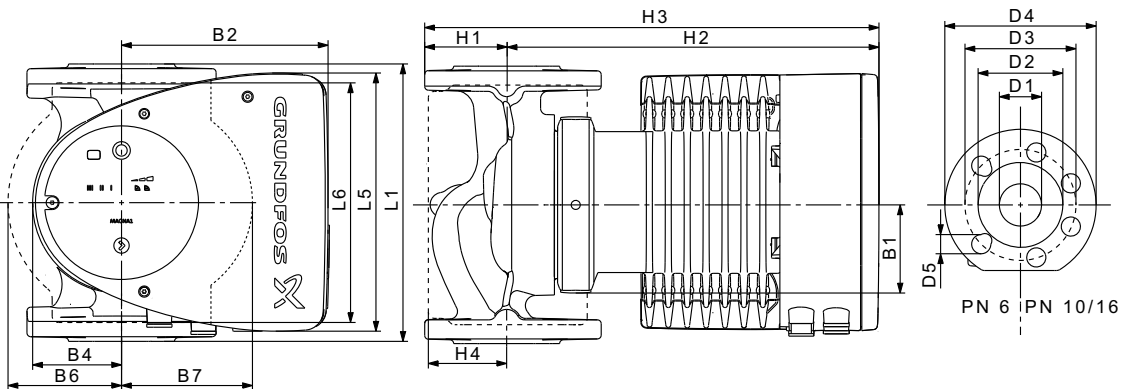

Pump type	Dimensions [mm]																
	L1	L5	L6	B1	B2	B4	B6	B7	H1	H2	H3	H4	D1	D2	D3	D4	D5
MAGNA1 80-60 F	360	204	310	84	164	73	163	163	96	318	413	115	80	128	150/160	200	19

For product numbers, see page 115.

TM05 6307 4712

TM05 5276 3512

MAGNA1 D 80-60 F PN 10

1 x 230 V, 50/60 Hz

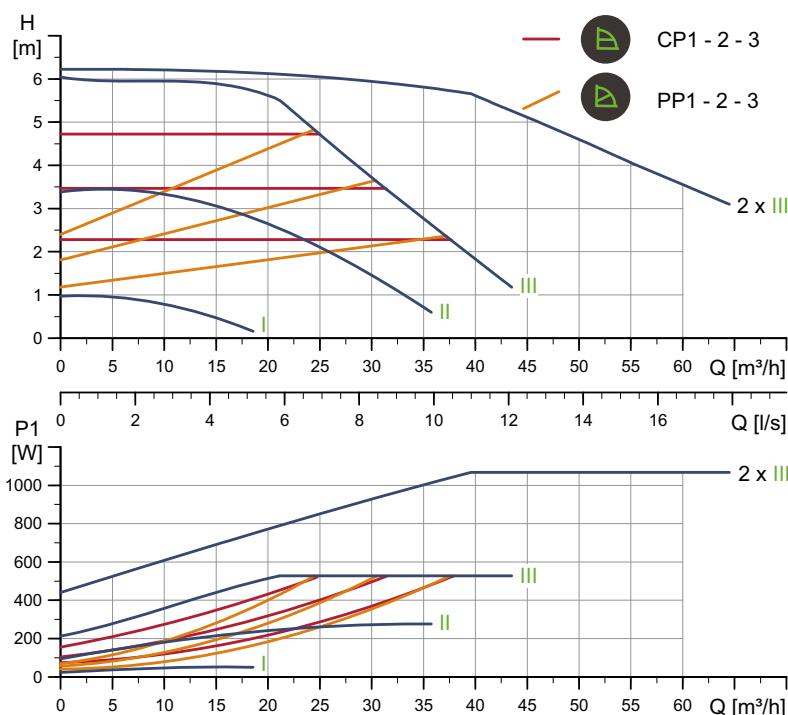

TM05 6354 4712

Speed	P1 [W]	I _{1/1} [A]
Min.	24.7	0.27
Max.	537	2.38

Connections: See section *Pipe connection*, page 110.
 System pressure: Max. 1.0 MPa (10 bar).
 Liquid temperature: -10 to 110 °C (TF 110).
 Specific EEI: 0.20.

The pump incorporates overload protection.

Net weight [kg]	Gross weight [kg]	Ship. vol. [m ³]
45.9	55.7	0.208

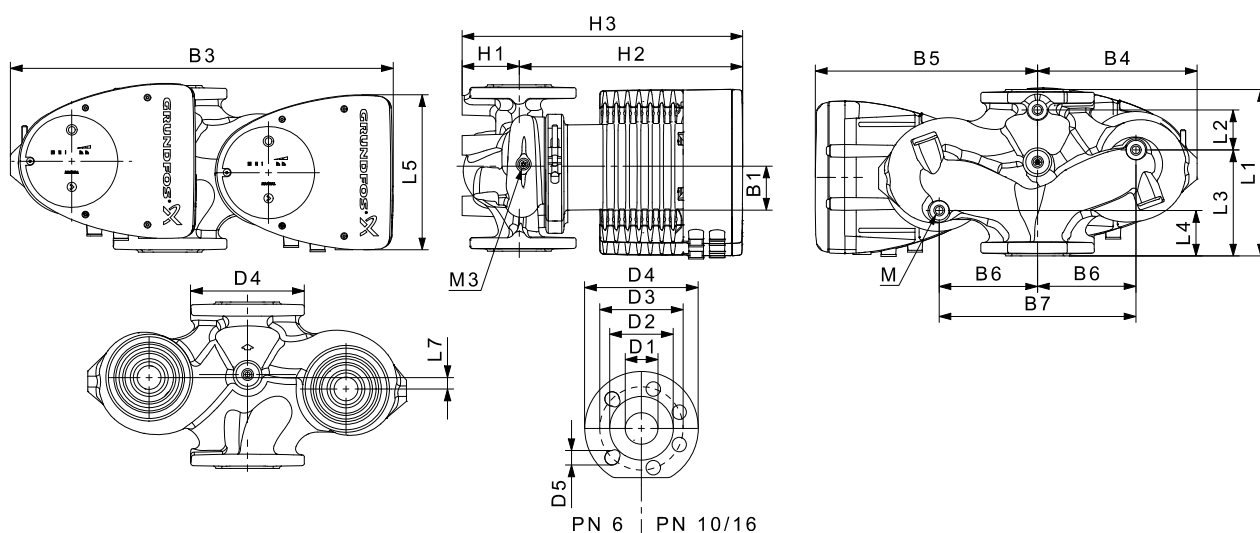

TM05 5275 3512

Pump type	Dimensions [mm]																	Rp				
	L1	L2	L3	L4	L5	L7	B1	B3	B4	B5	B6	B7	H1	H2	H3	D1	D2		D3	D4	D5	M
MAGNA1 D 80-60 F	360	218	102	102	204	0	84	538	244	294	130	260	97	318	415	80	128	150/160	200	19	12	1/4

For product numbers, see page 115.

MAGNA1 80-80 F PN 10

1 x 230 V, 50/60 Hz

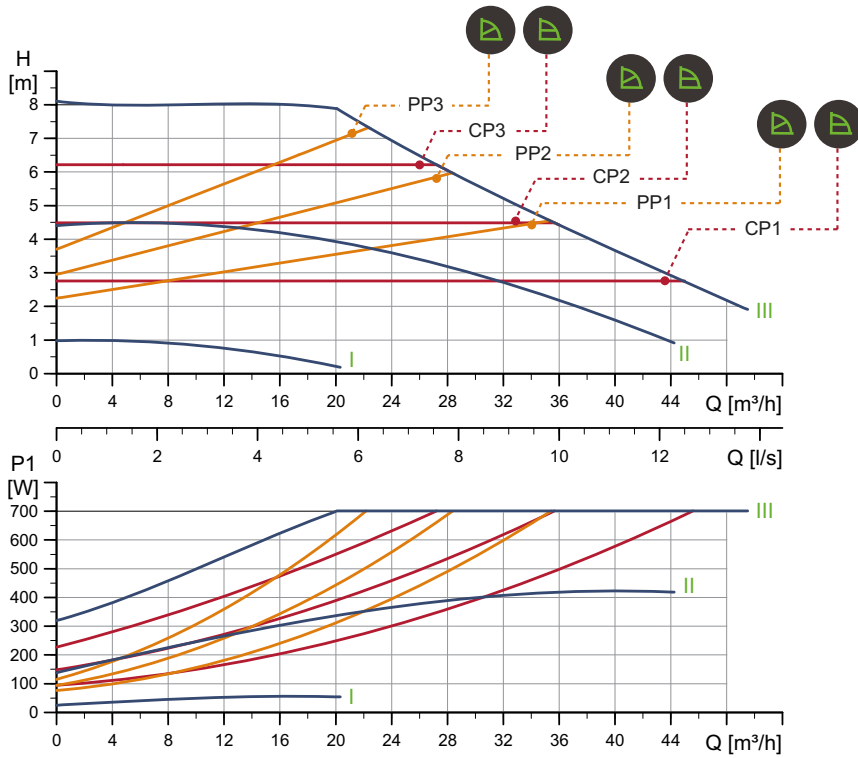

Speed	P1 [W]	I _{1/1} [A]
Min.	26.3	0.28
Max.	715	3.14

Connections: See section *Pipe connection*, page 110.
 System pressure: Max. 1.0 MPa (10 bar).
 Liquid temperature: -10 to 110 °C (TF 110).
 Specific EEI: 0.20.

The pump incorporates overload protection.

Net weight [kg]	Gross weight [kg]	Ship. vol. [m³]
29.6	32.0	0.072

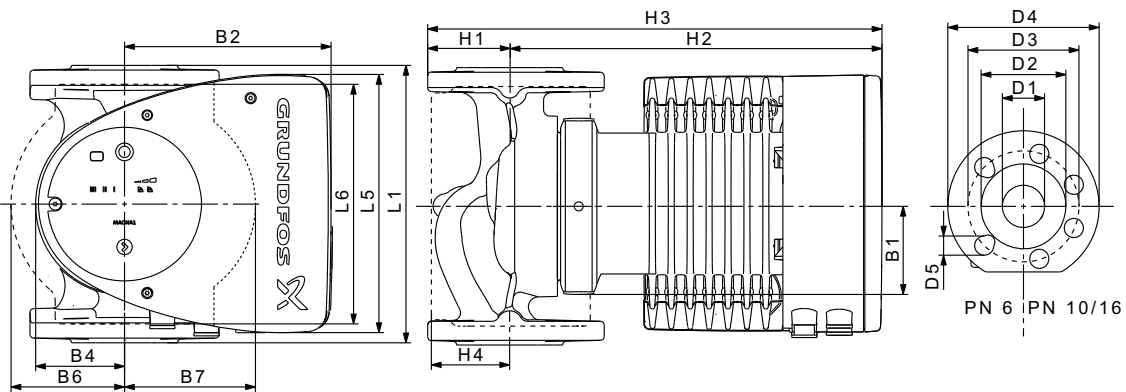

Pump type	Dimensions [mm]																
	L1	L5	L6	B1	B2	B4	B6	B7	H1	H2	H3	H4	D1	D2	D3	D4	D5
MAGNA1 80-80 F	360	204	310	84	164	73	163	163	96	318	413	115	80	128	150/160	200	19

For product numbers, see page 115.

TM05 6308 4712

TM05 6276 3512

MAGNA1 D 80-80 F PN 10

1 x 230 V, 50/60 Hz

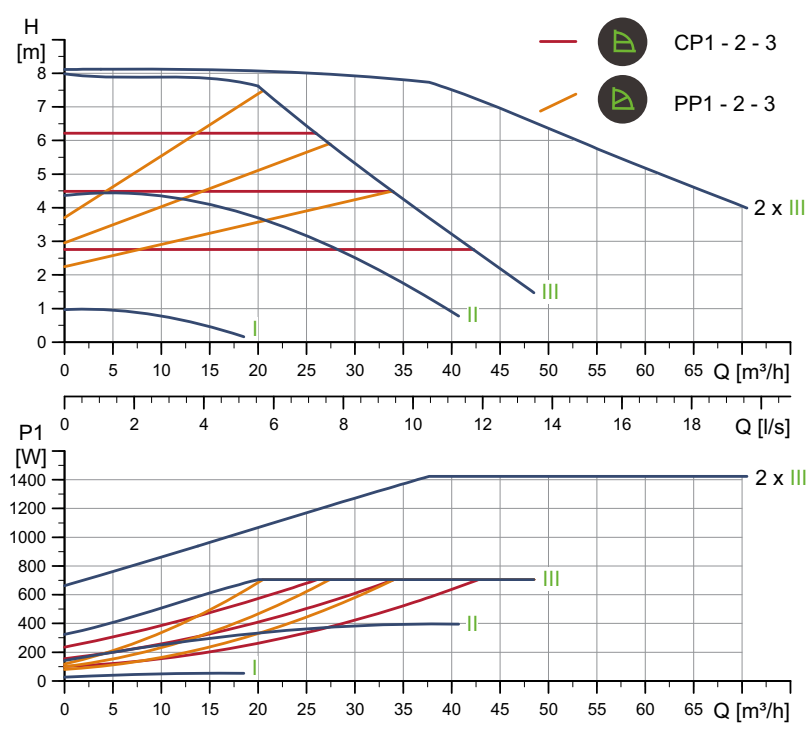

TM05 6355 4712

Speed	P1 [W]	I _{1/1} [A]
Min.	27.3	0.27
Max.	718	3.15

Connections: See section [Pipe connection](#), page 110.
 System pressure: Max. 1.0 MPa (10 bar).
 Liquid temperature: -10 to 110 °C (TF 110).
 Specific EEI: 0.21.

The pump incorporates overload protection.

Net weight [kg]	Gross weight [kg]	Ship. vol. [m ³]
51.6	61.3	0.208

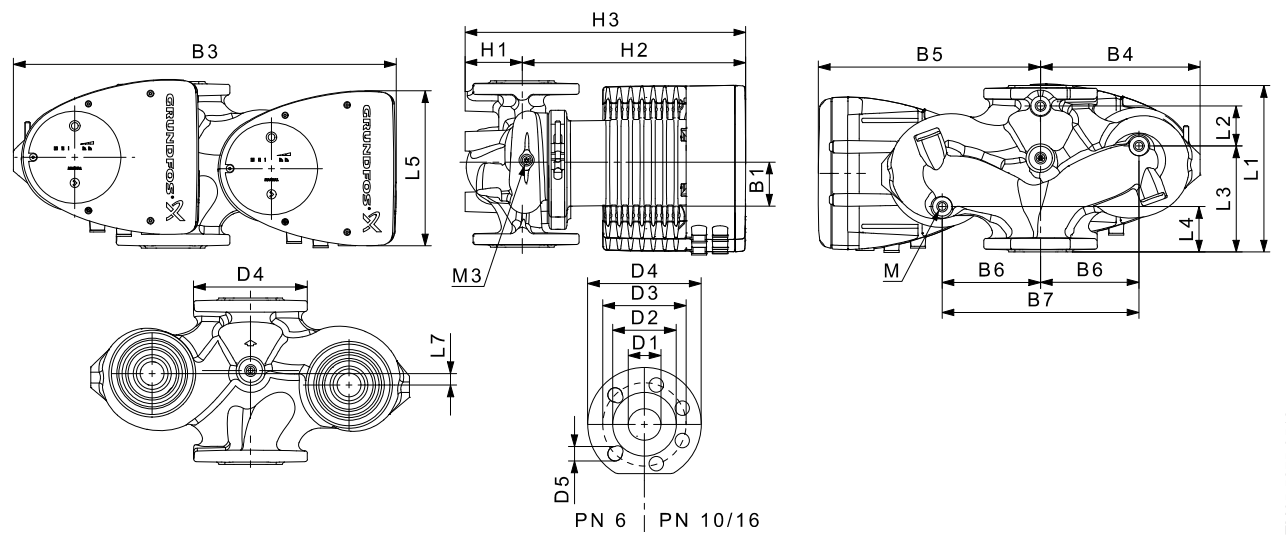

TM05 5275 3512

Pump type	Dimensions [mm]																	Rp				
	L1	L2	L3	L4	L5	L7	B1	B3	B4	B5	B6	B7	H1	H2	H3	D1	D2		D3	D4	D5	M
MAGNA1 D 80-80 F	360	218	102	102	204	0	84	538	244	294	130	260	97	318	415	80	128	150/160	200	19	12	1/4

For product numbers, see page 115.

MAGNA1 80-100 F PN 10

1 x 230 V, 50/60 Hz

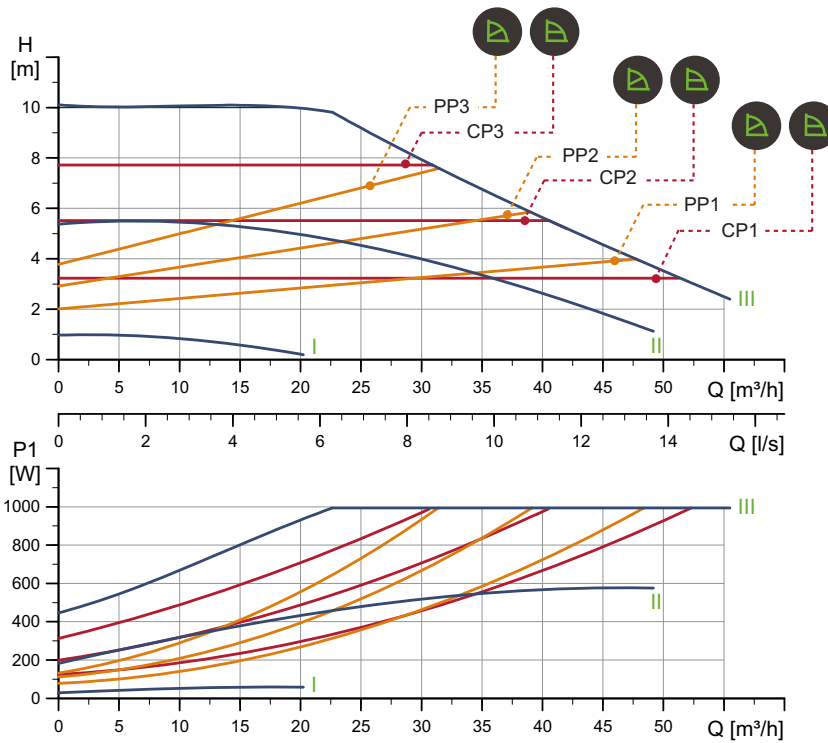

Speed	P1 [W]	I _{1/1} [A]
Min.	30.7	0.31
Max.	1014	4.45

Connections: See section [Pipe connection](#), page 110.
 System pressure: Max. 1.0 MPa (10 bar).
 Liquid temperature: -10 to 110 °C (TF 110).
 Specific EEI: 0.19.

The pump incorporates overload protection.

Net weight [kg]	Gross weight [kg]	Ship. vol. [m³]
30.2	32.6	0.072

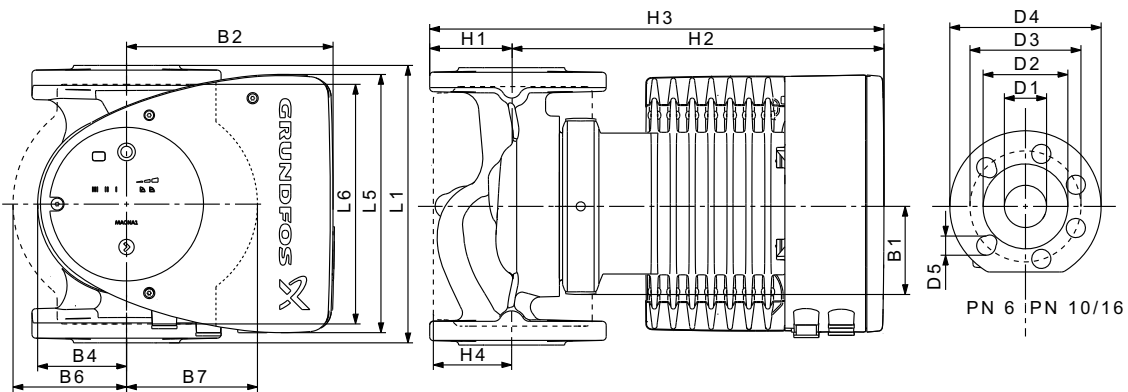

Pump type	Dimensions [mm]																
	L1	L5	L6	B1	B2	B4	B6	B7	H1	H2	H3	H4	D1	D2	D3	D4	D5
MAGNA1 80-100 F	360	204	310	84	164	73	163	163	96	318	413	115	80	128	150/160	200	19

For product numbers, see page 115.

TM05 6309 4712

TM05 5276 3512

MAGNA1 D 80-100 F PN 10

1 x 230 V, 50/60 Hz

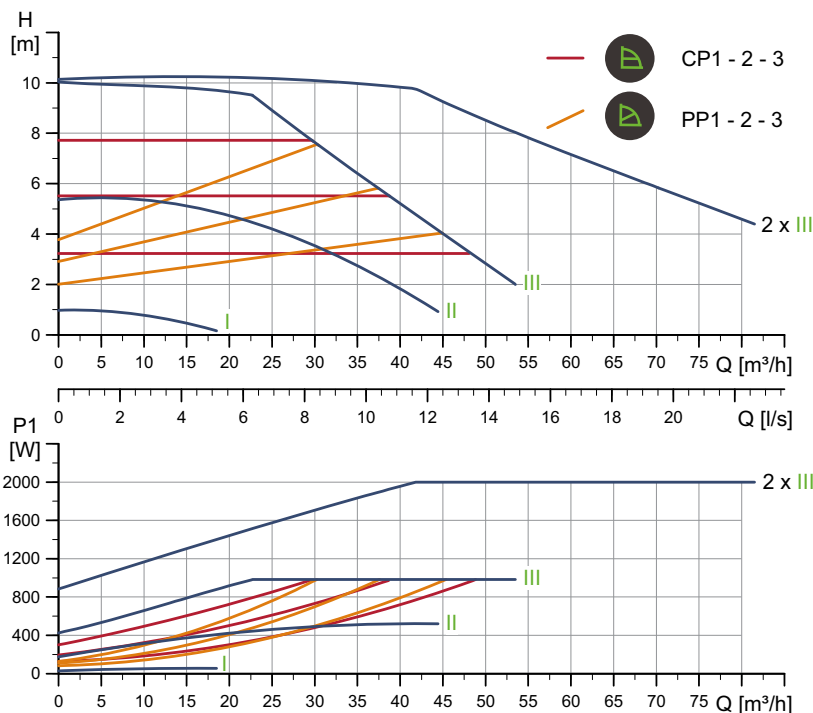

TM05 6356 4712

Speed	P1 [W]	I _{1/1} [A]
Min.	31	0.32
Max.	1002	4.41

Connections: See section [Pipe connection](#), page 110.
 System pressure: Max. 1.0 MPa (10 bar).
 Liquid temperature: -10 to 110 °C (TF 110).
 Specific EEI: 0.21.

The pump incorporates overload protection.

Net weight [kg]	Gross weight [kg]	Ship. vol. [m ³]
52.7	62.5	0.208

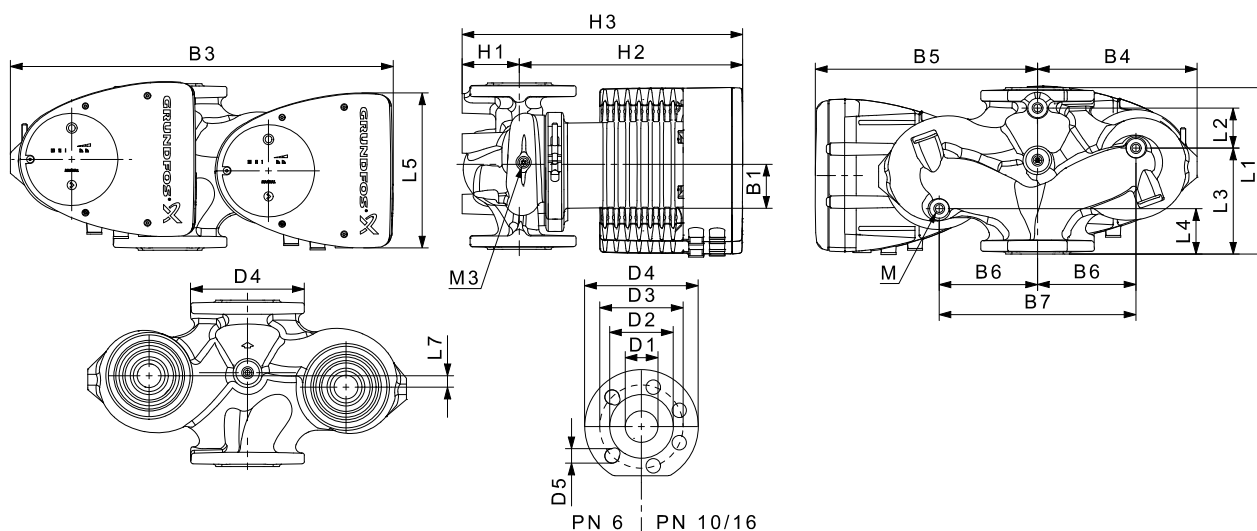

TM05 5275 3512

Pump type	Dimensions [mm]																	Rp				
	L1	L2	L3	L4	L5	L7	B1	B3	B4	B5	B6	B7	H1	H2	H3	D1	D2		D3	D4	D5	M
MAGNA1 D 80-100 F	360	218	102	102	204	0	84	538	244	294	130	260	97	318	415	80	128	150/160	200	19	12	1/4

For product numbers, see page 115.

MAGNA1 80-120 F PN 10

1 x 230 V, 50/60 Hz

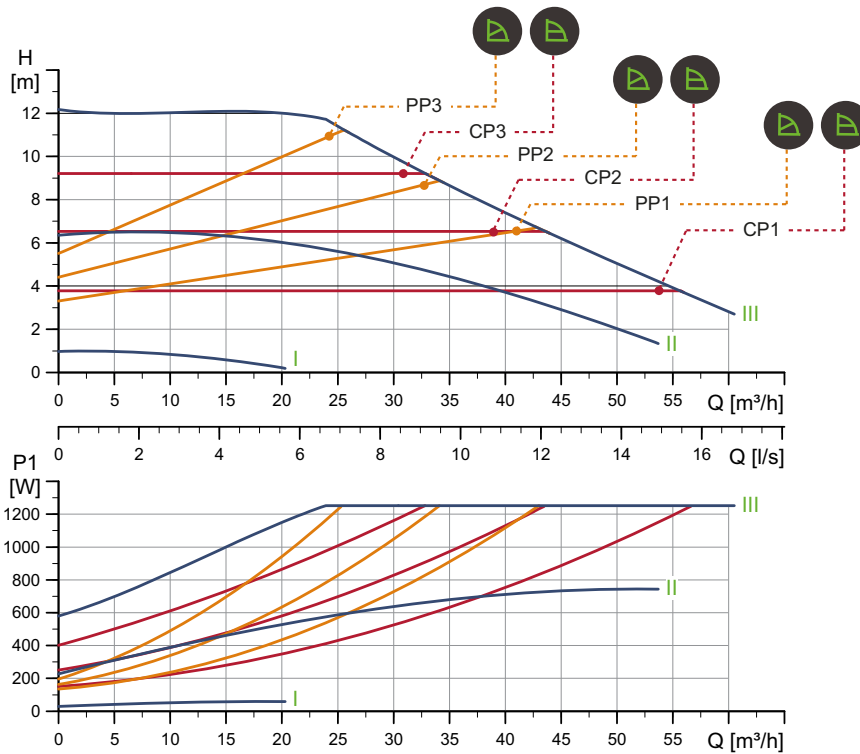

Speed	P1 [W]	I _{1/1} [A]
Min.	30.5	0.31
Max.	1277	5.59

Connections: See section *Pipe connection*, page 110.
 System pressure: Max. 1.0 MPa (10 bar).
 Liquid temperature: -10 to 110 °C (TF 110).
 Specific EEI: 0.19.

The pump incorporates overload protection.

Net weight [kg]	Gross weight [kg]	Ship. vol. [m³]
30.2	32.6	0.072

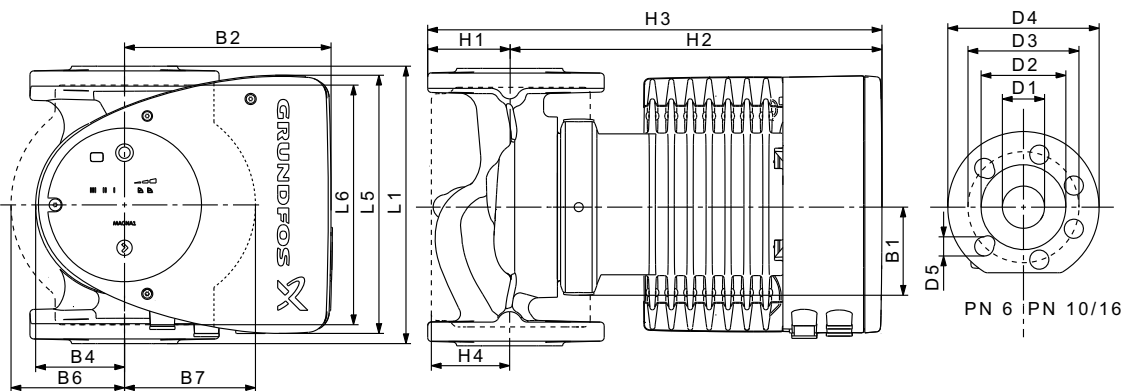

Pump type	Dimensions [mm]																
	L1	L5	L6	B1	B2	B4	B6	B7	H1	H2	H3	H4	D1	D2	D3	D4	D5
MAGNA1 80-120 F	360	204	310	84	164	73	163	163	96	318	413	115	80	128	150/160	200	19

For product numbers, see page 115.

TM05 6310 4712

TM05 6276 3512

MAGNA1 D 80-120 F PN 10

1 x 230 V, 50/60 Hz

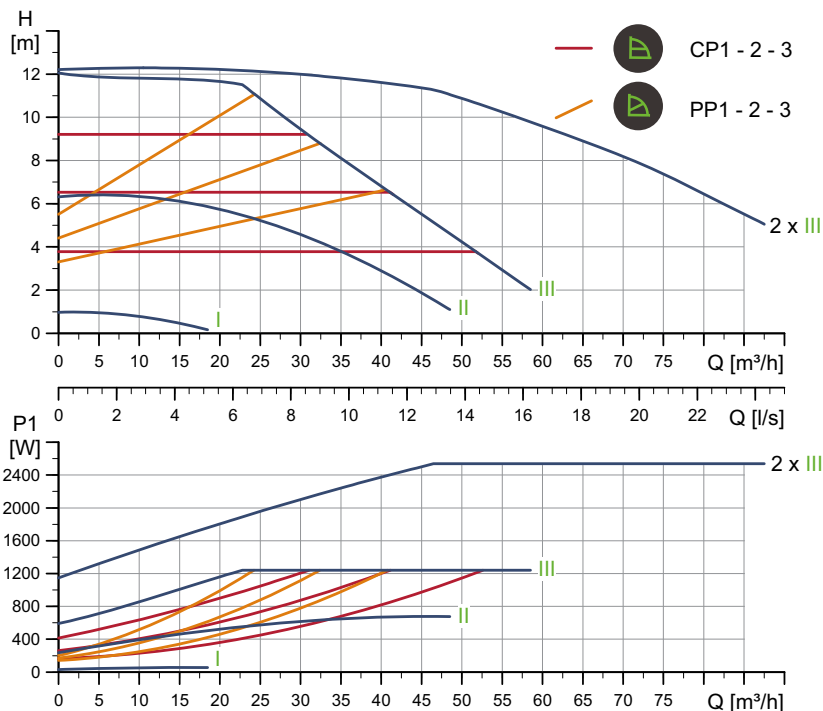

TM05 6357 4712

Speed	P1 [W]	I _{1/1} [A]
Min.	32.2	0.33
Max.	1265	5.54

Connections: See section [Pipe connection](#), page 110.
 System pressure: Max. 1.0 MPa (10 bar).
 Liquid temperature: -10 to 110 °C (TF 110).
 Specific EEI: 0.21.

The pump incorporates overload protection.

Net weight [kg]	Gross weight [kg]	Ship. vol. [m ³]
52.7	62.5	0.208

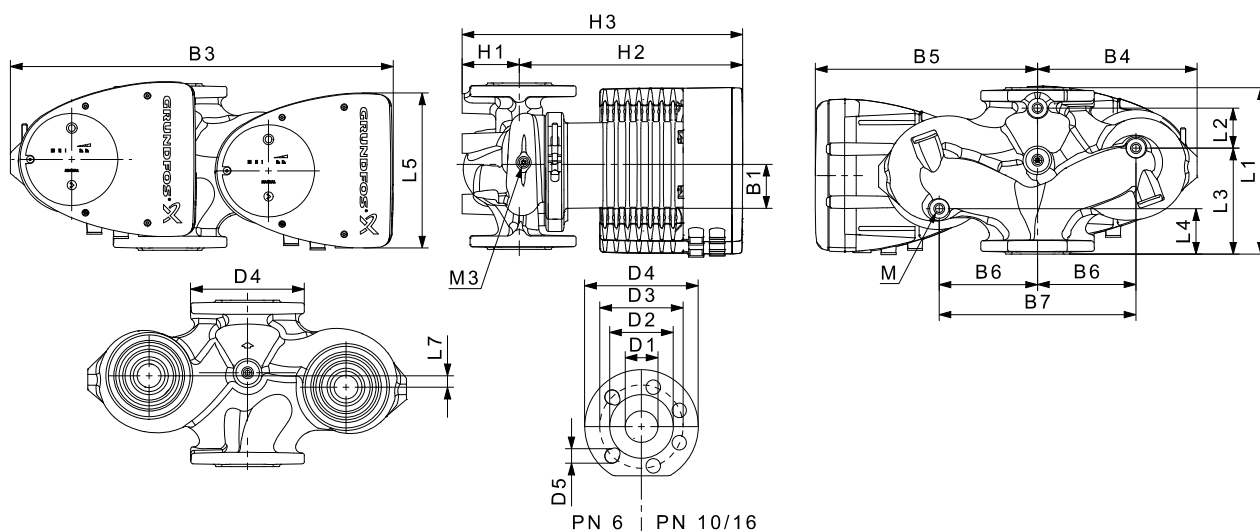

TM05 5275 3512

Pump type	Dimensions [mm]																	Rp				
	L1	L2	L3	L4	L5	L7	B1	B3	B4	B5	B6	B7	H1	H2	H3	D1	D2	D3	D4	D5	M	M3
MAGNA1 D 80-120 F	360	218	102	102	204	0	84	538	244	294	130	260	97	318	415	80	128	150/160	200	19	12	1/4

For product numbers, see page 115.

MAGNA1 100-40 F PN 10

1 x 230 V, 50/60 Hz

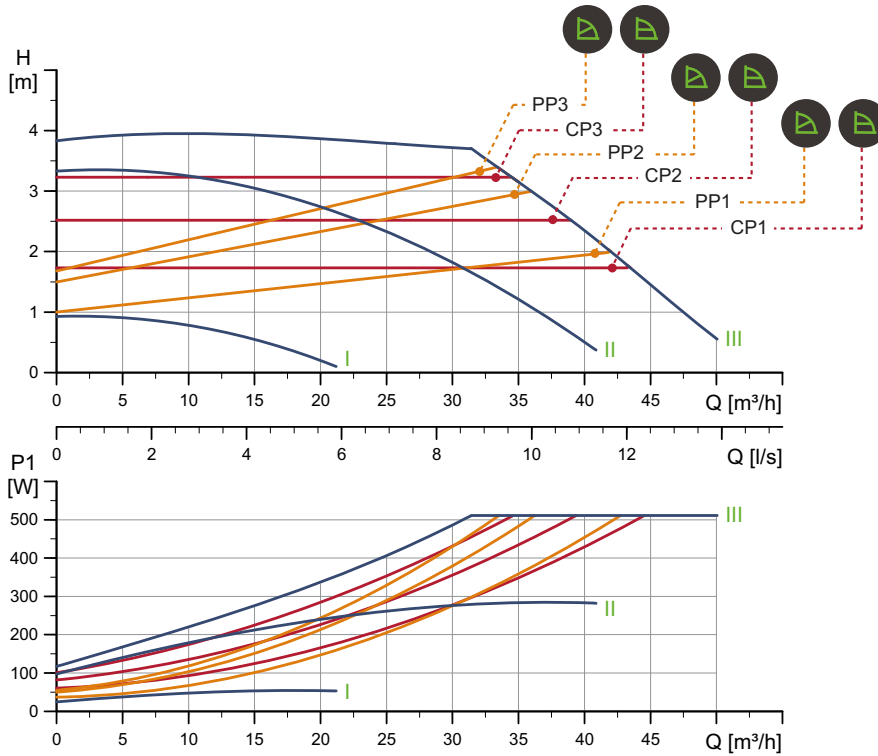

Speed	P1 [W]	I _{1/I1} [A]
Min.	26	0.27
Max.	521	2.32

Connections: See section *Pipe connection*, page 110.
 System pressure: Max. 1.0 MPa (10 bar).
 Liquid temperature: -10 to 110 °C (TF 110).
 Specific EEI: 0.19.

The pump incorporates overload protection.

Net weight [kg]	Gross weight [kg]	Ship. vol. [m ³]
34.2	36.4	0.099

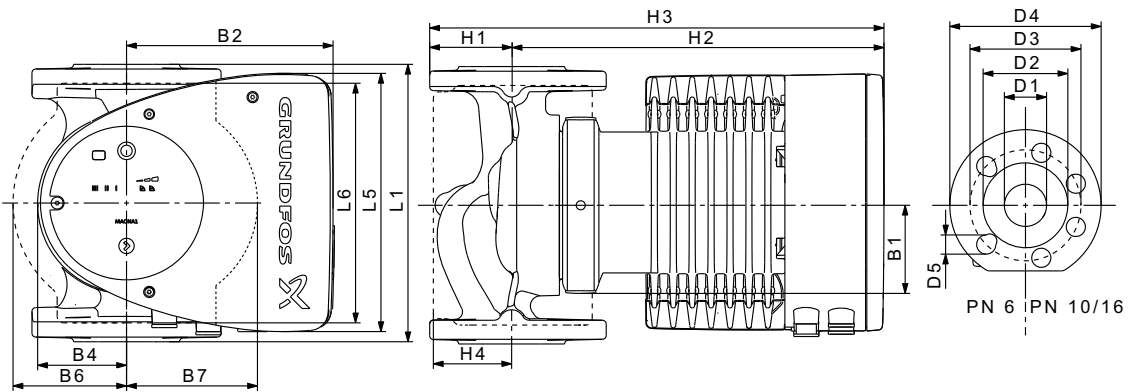

Pump type	Dimensions [mm]																
	L1	L5	L6	B1	B2	B4	B6	B7	H1	H2	H3	H4	D1	D2	D3	D4	D5
MAGNA1 100-40 F	450	204	396	84	164	73	178	178	103	330	433	120	100	160	170	220	19

For product numbers, see page 115.

TM05 6311 4712

TM05 5276 3512

MAGNA1 D 100-40 F PN 10

1 x 230 V, 50/60 Hz

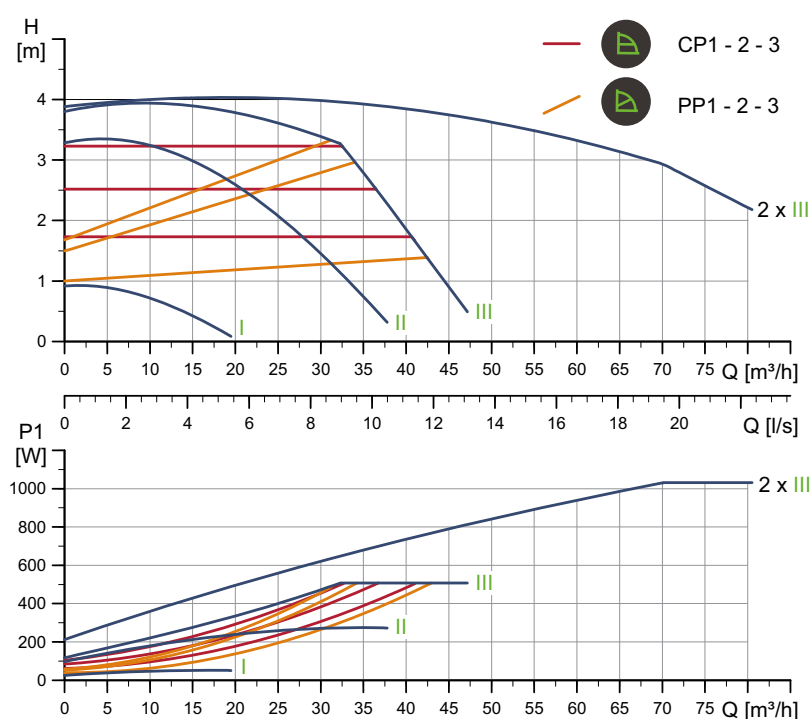

Speed	P1 [W]	I _{1/1} [A]
Min.	26	0.27
Max.	518	2.3

Connections: See section *Pipe connection*, page 110.
 System pressure: Max. 1.0 MPa (10 bar).
 Liquid temperature: -10 to 110 °C (TF 110).
 Specific EEI: 0.19.

The pump incorporates overload protection.

Net weight [kg]	Gross weight [kg]	Ship. vol. [m ³]
62.1	72.0	0.208

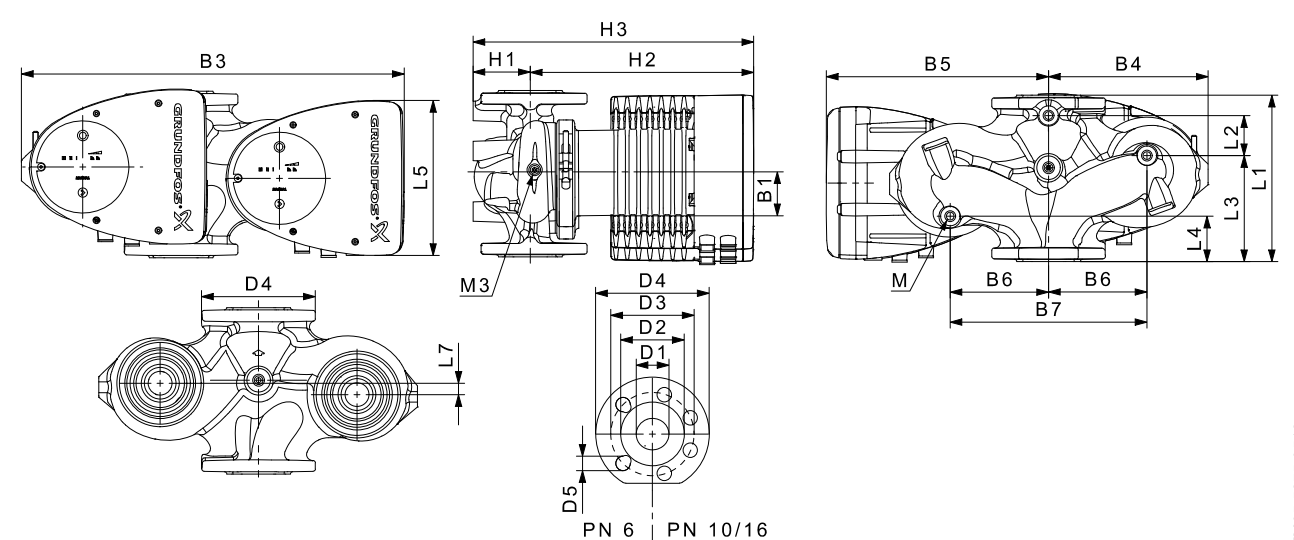

Pump type	Dimensions [mm]																			Rp		
	L1	L2	L3	L4	L5	L7	B1	B3	B4	B5	B6	B7	H1	H2	H3	D1	D2	D3	D4		D5	M
MAGNA1 D 100-40 F	450	243	147	147	204	0	84	551	252	299	135	270	103	330	434	100	160	170	220	19	12	1/4

For product numbers, see page 115.

TM05 6358 4712

TM05 5275 3512

MAGNA1 100-60 F PN 10

1 x 230 V, 50/60 Hz

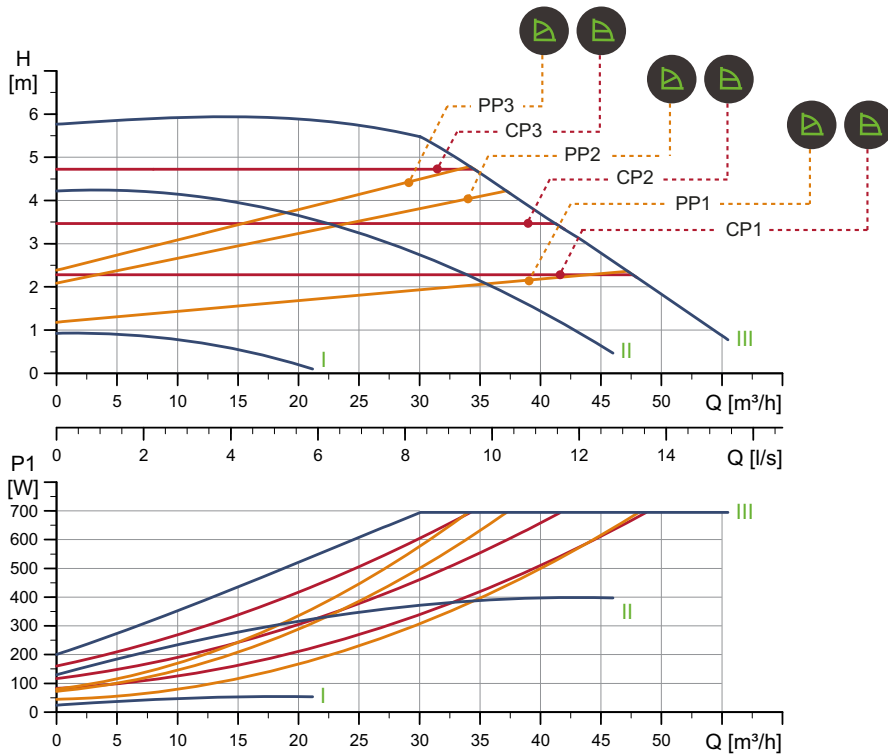

TM05 6312 4712

Speed	P1 [W]	I _{1/1} [A]
Min.	25.6	0.27
Max.	708	3.13

Connections: See section *Pipe connection*, page 110.
 System pressure: Max. 1.0 MPa (10 bar).
 Liquid temperature: -10 to 110 °C (TF 110).
 Specific EEI: 0.19.

The pump incorporates overload protection.

Net weight [kg]	Gross weight [kg]	Ship. vol. [m³]
34.2	36.4	0.099

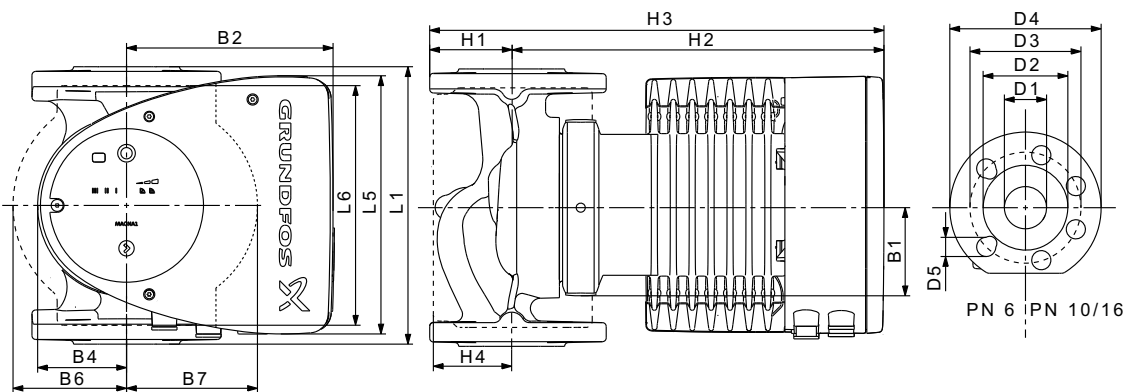

TM05 5276 3512

Pump type	Dimensions [mm]																
	L1	L5	L6	B1	B2	B4	B6	B7	H1	H2	H3	H4	D1	D2	D3	D4	D5
MAGNA1 100-60 F	450	204	396	84	164	73	178	178	103	330	433	120	100	160	170	220	19

For product numbers, see page 115.

MAGNA1 D 100-60 F PN 10

1 x 230 V, 50/60 Hz

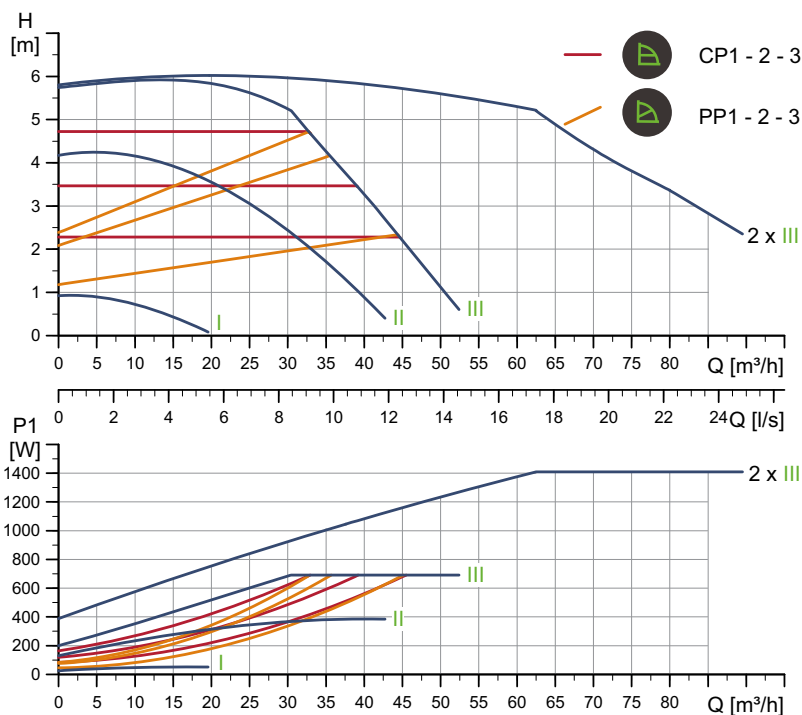

TM05 6359 4712

Speed	P1 [W]	I _{1/1} [A]
Min.	26.1	0.28
Max.	705	3.11

Connections: See section [Pipe connection](#), page 110.
 System pressure: Max. 1.0 MPa (10 bar).
 Liquid temperature: -10 to 110 °C (TF 110).
 Specific EEI: 0.22.

The pump incorporates overload protection.

Net weight [kg]	Gross weight [kg]	Ship. vol. [m³]
62.1	72.0	0.208

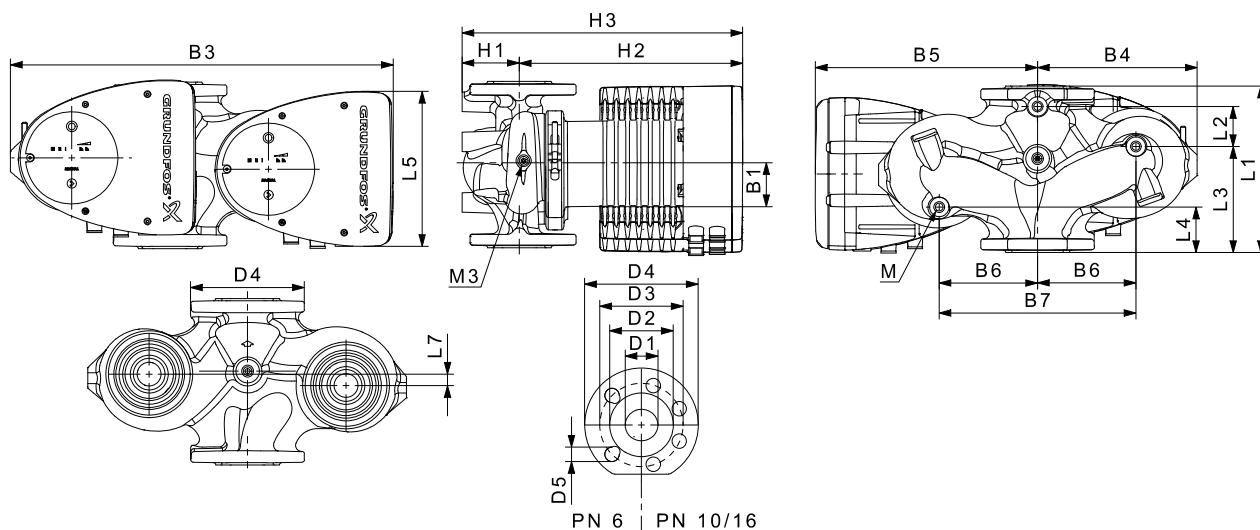

TM05 5275 3512

Pump type	Dimensions [mm]																Rp					
	L1	L2	L3	L4	L5	L7	B1	B3	B4	B5	B6	B7	H1	H2	H3	D1		D2	D3	D4	D5	M
MAGNA1 D 100-60 F	450	243	147	147	204	0	84	551	252	299	135	270	103	330	434	100	160	170	220	19	12	1/4

For product numbers, see page 115.

MAGNA1 100-80 F PN 10

1 x 230 V, 50/60 Hz

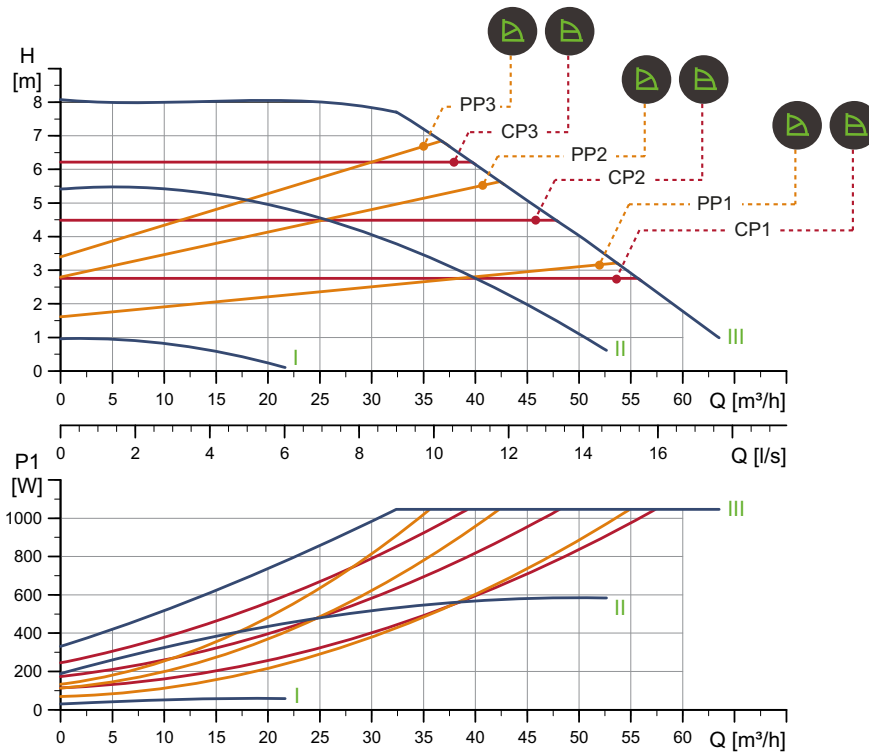

Speed	P1 [W]	I _{1/1} [A]
Min.	31.4	0.32
Max.	1067	4.71

Connections: See section *Pipe connection*, page 110.
 System pressure: Max. 1.0 MPa (10 bar).
 Liquid temperature: -10 to 110 °C (TF 110).
 Specific EEI: 0.19.

The pump incorporates overload protection.

Net weight [kg]	Gross weight [kg]	Ship. vol. [m ³]
34.8	37.0	0.099

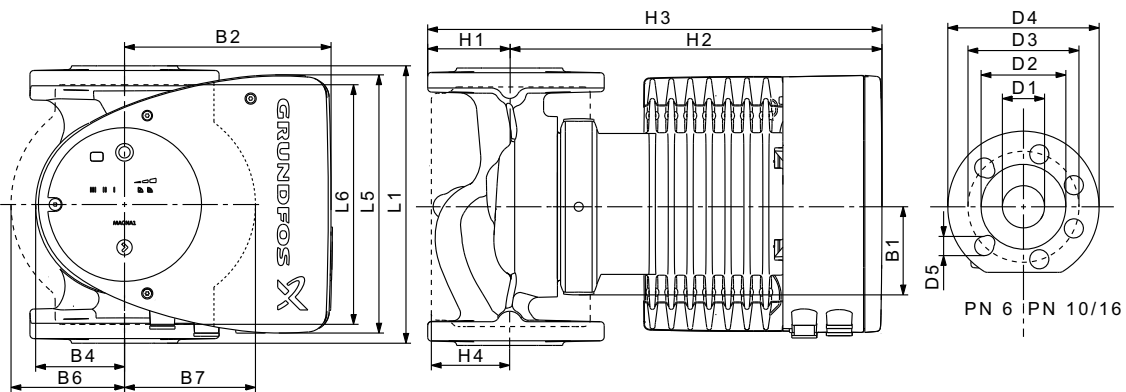

Pump type	Dimensions [mm]																
	L1	L5	L6	B1	B2	B4	B6	B7	H1	H2	H3	H4	D1	D2	D3	D4	D5
MAGNA1 100-80 F	450	204	396	84	164	73	178	178	103	330	433	120	100	160	170	220	19

For product numbers, see page 115.

TM05 6313 4712

TM05 5276 3512

MAGNA1 D 100-80 F PN 10

1 x 230 V, 50/60 Hz

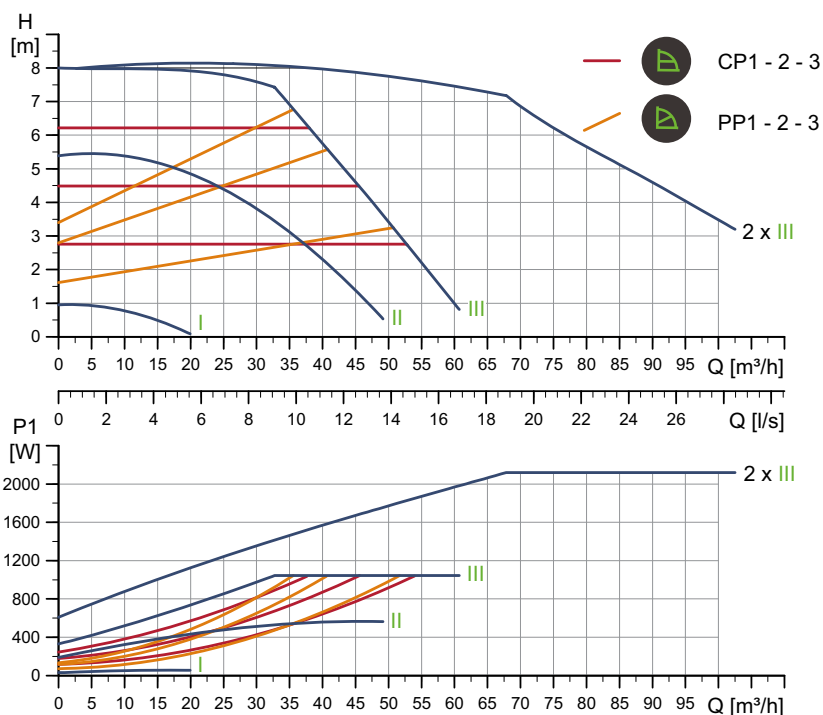

TM05 6360 4712

Speed	P1 [W]	I _{1/1} [A]
Min.	31.3	0.32
Max.	1066	4.70

Connections: See section [Pipe connection](#), page 110.
 System pressure: Max. 1.0 MPa (10 bar).
 Liquid temperature: -10 to 110 °C (TF 110).
 Specific EEI: 0.22.

The pump incorporates overload protection.

Net weight [kg]	Gross weight [kg]	Ship. vol. [m³]
62.3	72.2	0.208

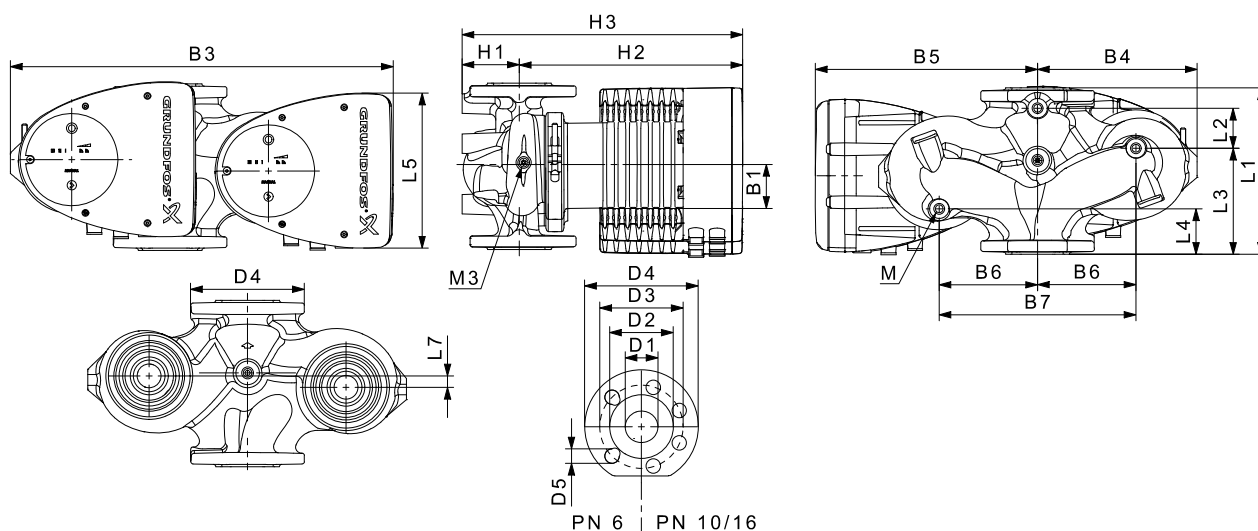

TM05 5275 3512

Pump type	Dimensions [mm]																	Rp				
	L1	L2	L3	L4	L5	L7	B1	B3	B4	B5	B6	B7	H1	H2	H3	D1	D2		D3	D4	D5	M
MAGNA1 D 100-80 F	450	243	147	147	204	0	84	551	252	299	135	270	103	330	434	100	160	170	220	19	12	1/4

For product numbers, see page 115.

MAGNA1 100-100 F PN 10

1 x 230 V, 50/60 Hz

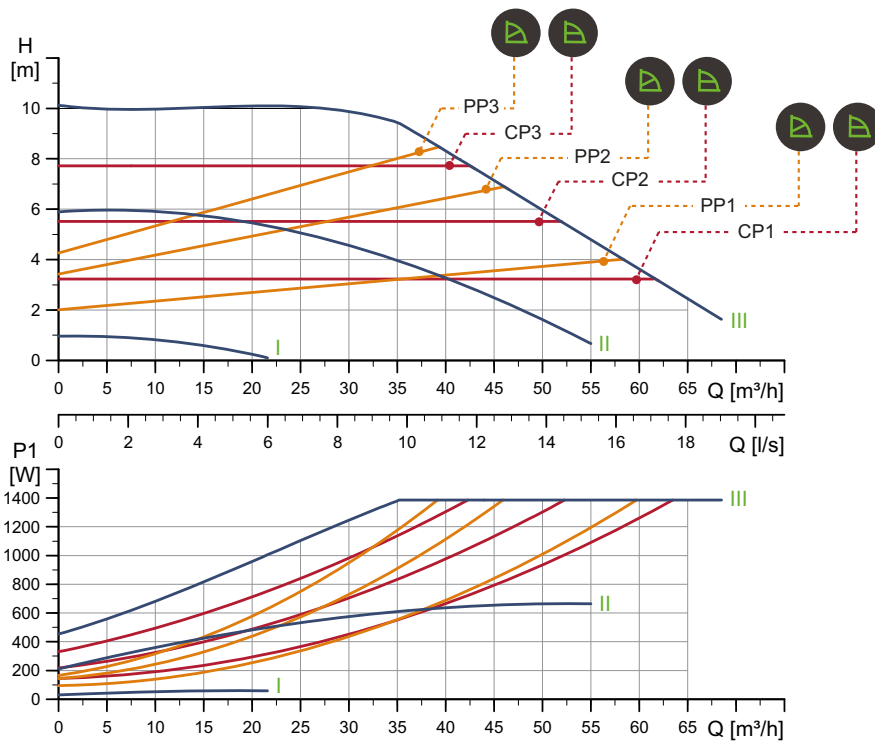

Speed	P1 [W]	I _{1/1} [A]
Min.	31.3	0.32
Max.	1413	6.23

Connections: See section [Pipe connection](#), page 110.
 System pressure: Max. 1.0 MPa (10 bar).
 Liquid temperature: -10 to 110 °C (TF 110).
 Specific EEI: 0.19.

The pump incorporates overload protection.

Net weight [kg]	Gross weight [kg]	Ship. vol. [m³]
34.8	37.0	0.099

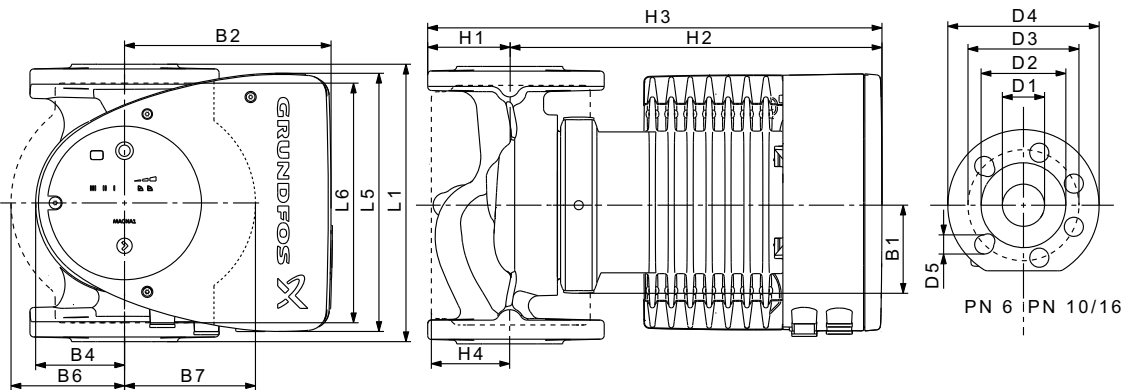

Pump type	Dimensions [mm]																
	L1	L5	L6	B1	B2	B4	B6	B7	H1	H2	H3	H4	D1	D2	D3	D4	D5
MAGNA1 100-100 F	450	204	396	84	164	73	178	178	103	330	433	120	100	160	170	220	19

For product numbers, see page 115.

TM05 6314 4712

TM05 5276 3512

MAGNA1 D 100-100 F PN 10

1 x 230 V, 50/60 Hz

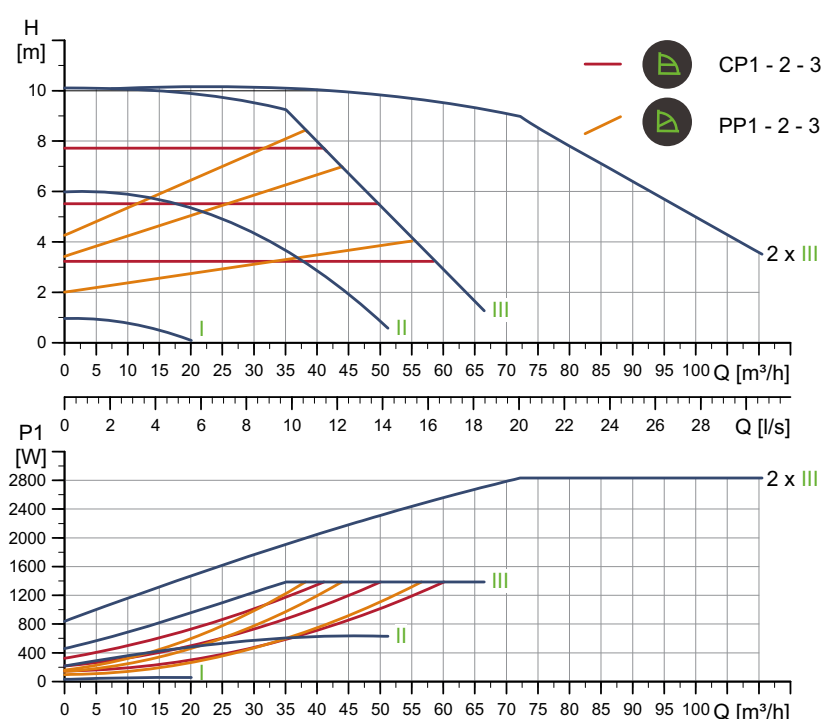

Speed	P1 [W]	I _{1/1} [A]
Min.	31.1	0.32
Max.	1413	6.23

Connections: See section [Pipe connection](#), page 110.
 System pressure: Max. 1.0 MPa (10 bar).
 Liquid temperature: -10 to 110 °C (TF 110).
 Specific EEI: 0.19.

The pump incorporates overload protection.

Net weight [kg]	Gross weight [kg]	Ship. vol. [m ³]
62.3	72.2	0.208

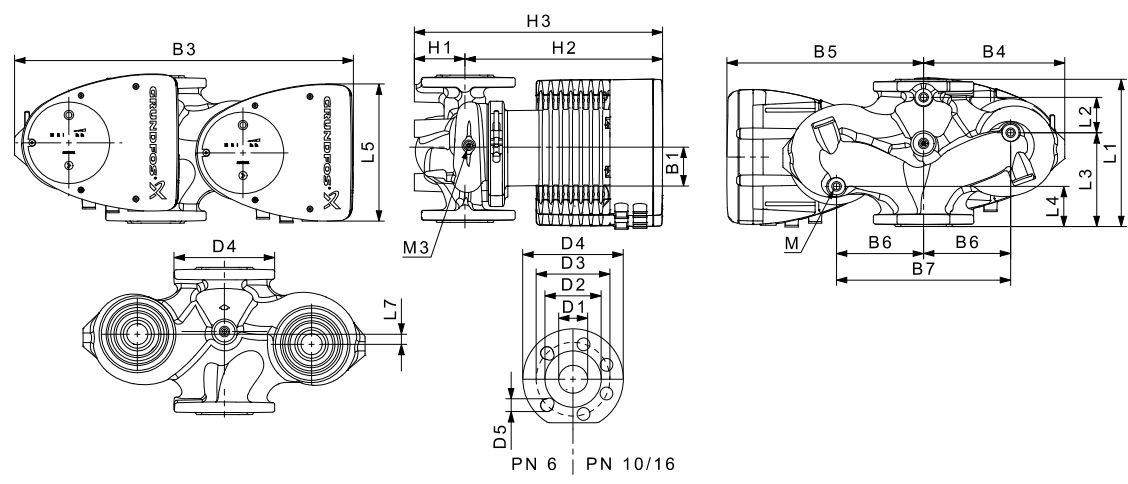

Pump type	Dimensions [mm]																				Rp	
	L1	L2	L3	L4	L5	L7	B1	B3	B4	B5	B6	B7	H1	H2	H3	D1	D2	D3	D4	D5		M
MAGNA1 D 100-100 F	450	243	147	147	204	0	84	551	252	299	135	270	103	330	434	100	160	170	220	19	12	1/4

For product numbers, see page 115.

TM05 6361 4712

TM05 5275 3512

MAGNA1 100-120 F PN 10

1 x 230 V, 50/60 Hz

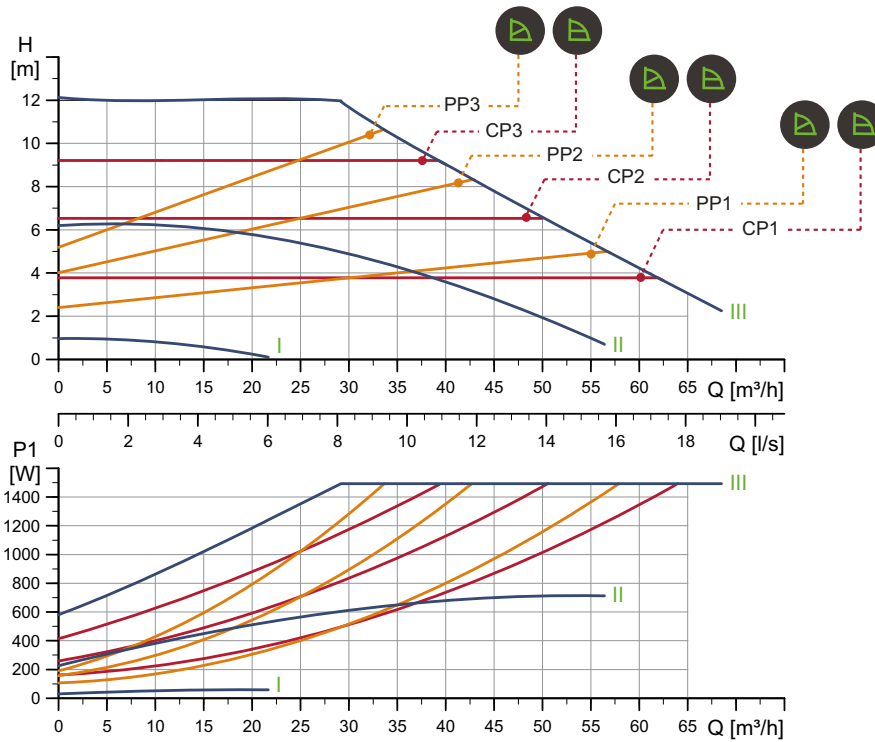

Speed	P1 [W]	I _{1/1} [A]
Min.	31.1	0.32
Max.	1523	6.73

Connections: See section [Pipe connection](#), page 110.
 System pressure: Max. 1.0 MPa (10 bar).
 Liquid temperature: -10 to 110 °C (TF 110).
 Specific EEI: 0.20.

The pump incorporates overload protection.

Net weight [kg]	Gross weight [kg]	Ship. vol. [m³]
34.8	37.0	0.099

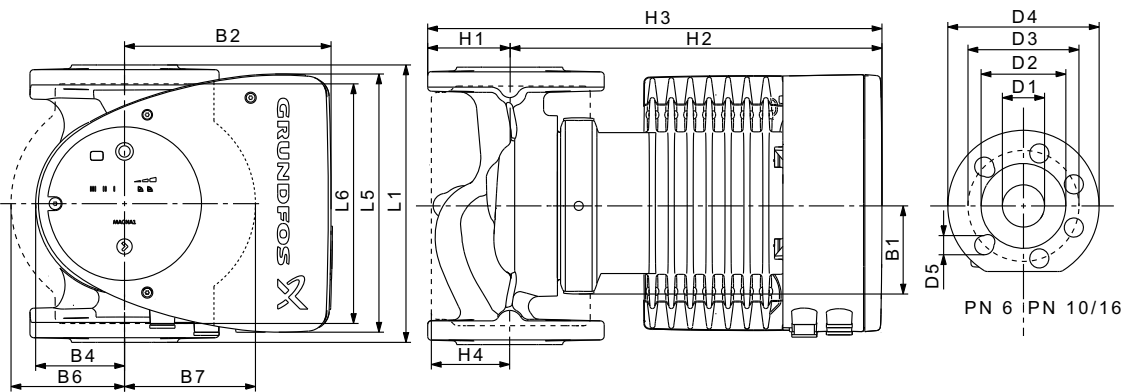

Pump type	Dimensions [mm]																
	L1	L5	L6	B1	B2	B4	B6	B7	H1	H2	H3	H4	D1	D2	D3	D4	D5
MAGNA1 100-120 F	450	204	396	84	164	73	178	178	103	330	433	120	100	160	170	220	19

For product numbers, see page 115.

TM05 6315 4712

TM05 5276 3512

MAGNA1 D 100-120 F PN 10

1 x 230 V, 50/60 Hz

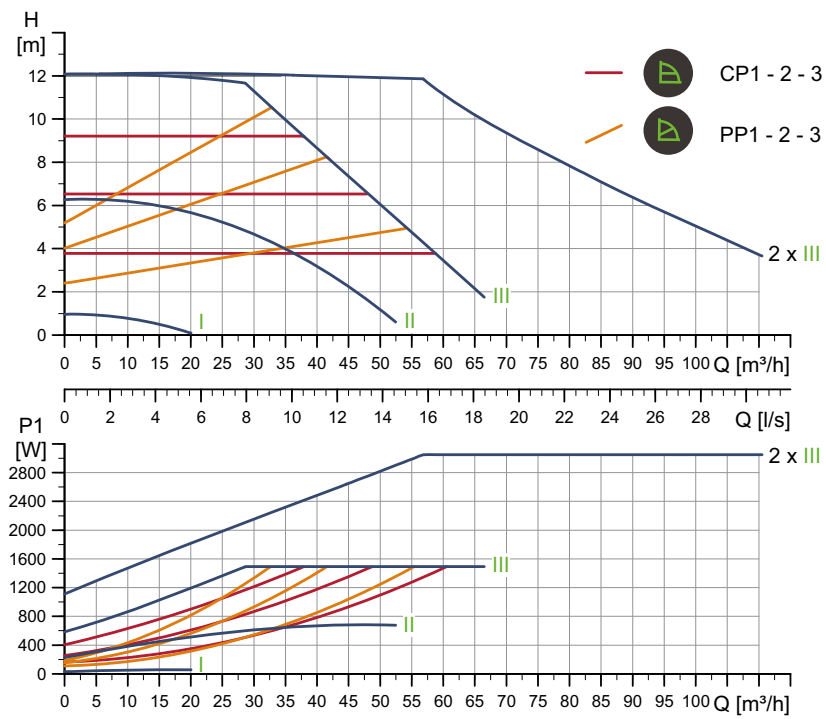

TM05 6362.4712

Speed	P1 [W]	I _{1/1} [A]
Min.	31.2	0.32
Max.	1521	6.71

Connections: See section [Pipe connection](#), page 110.
 System pressure: Max. 1.0 MPa (10 bar).
 Liquid temperature: -10 to 110 °C (TF 110).
 Specific EEI: 0.22.

The pump incorporates overload protection.

Net weight [kg]	Gross weight [kg]	Ship. vol. [m ³]
62.3	72.7	0.208

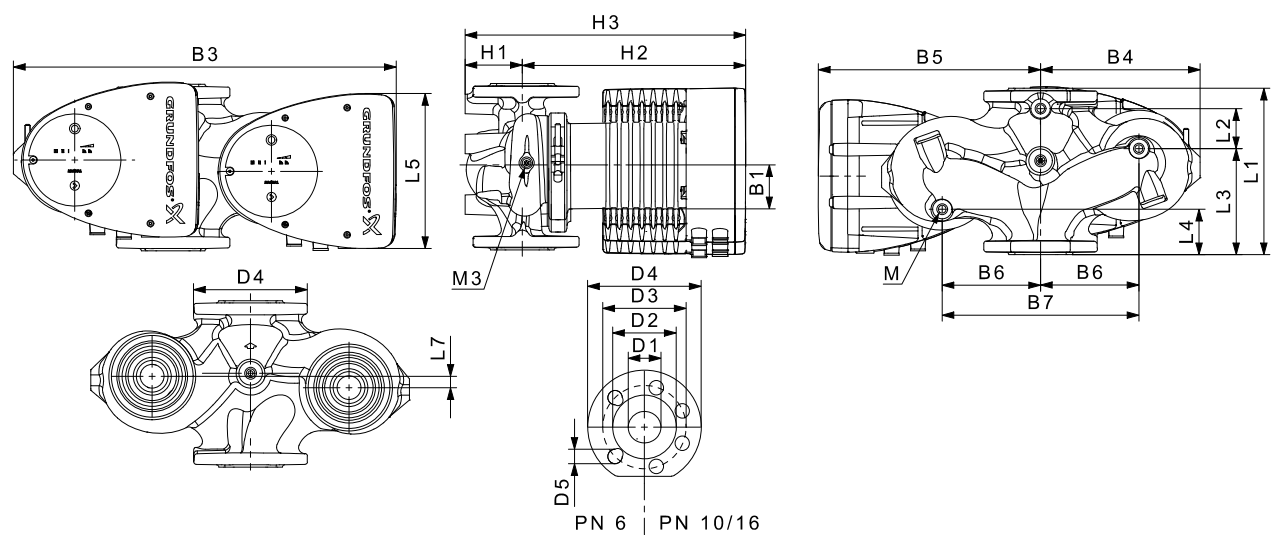

TM05 5275 3512

Pump type	Dimensions [mm]																			Rp		
	L1	L2	L3	L4	L5	L7	B1	B3	B4	B5	B6	B7	H1	H2	H3	D1	D2	D3	D4		D5	M
MAGNA1 D 100-120 F	450	243	147	147	204	0	84	551	252	299	135	270	103	330	434	100	160	170	220	19	12	1/4

For product numbers, see page 115.

8. Accessories

Insulating kits for air-conditioning and cooling systems

You can fit single-head pumps for air-conditioning and cooling systems with insulating shells. A kit consists of two shells made of polyurethane and a self-adhesive seal to ensure tight assembly.



TM05 5529 3812

Fig. 24 Fitting the insulating shells to a MAGNA1 pump

Note: The dimensions of the insulating shells for air-conditioning and cooling systems differ from those of the insulating shells for heating systems. You can use the insulating shells for both stainless-steel and cast-iron pumps.

Pump type	Product number
MAGNA1 25-40/60/80/100/120 (N)	98538852
MAGNA1 32-40/60/80/100/120 (N)	98538853
MAGNA1 32-40/60/80/100 F (N)	98538854
MAGNA1 32-120 F (N)	98164595
MAGNA1 40-40/60 F (N)	98538855
MAGNA1 40-80/100 F (N)	98164597
MAGNA1 40-120/150/180 F (N)	98164598
MAGNA1 50-60/80 F (N)	98164599
MAGNA1 50-100/120/150/180 F (N)	98164600
MAGNA1 65-40/60/80/100/120/150 F (N)	98538839
MAGNA1 80-60/80/100/120 F	98538851
MAGNA1 100-40/60/80/100/120 F	98164611

Note: Insulating shells for single-head pumps for heating systems are supplied with the pump.

Specifications

- Specific volume resistance $\geq 10^{15}$ Ωcm DIN 60093
- thermal conductivity at 10 °C 0.036 W/mK and at 40 °C 0.039 W/mK DIN 52612
- density 33 ± 5 kg/m³ ISO 845
- working temperature range -40 to +90 °C ISO 2796.

Blanking flanges

When you have removed one of the pumps of a twin-head pump for service, you can blank off the opening with a blanking flange to enable uninterrupted operation of the other pump.

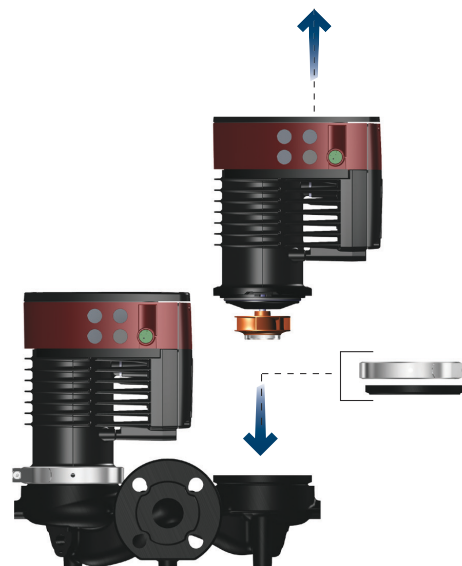

TM06 8518 0817

Fig. 25 Position of blanking flange

Pump type	Product number
MAGNA1 D 25-40/60/80/100/120	98159373
MAGNA1 D 32-40/60/80/100 (F)	
MAGNA1 D 40-40/60 F	
MAGNA1 D 32-120 F	98159372
MAGNA1 D 40-80/100/120/150/180 F	
MAGNA1 D 50-40/60/80/100/120/150/180 F	
MAGNA1 D 65-40/60/80/100/120/150 F	
MAGNA1 D 80-40/60/80/100/120 F	
MAGNA1 D 100-40/60/80/100/120 F	

ALPHA plug accessories



TM05 3073 0612

Fig. 26 ALPHA plugs

Pos.	Description	Product number
1	ALPHA plug, standard plug connection	98284561
2	ALPHA angle plug, standard angle plug connection	98610291
3	ALPHA plug, 90 ° bend, including 4 m cable	96884669

Grundfos GO

MAGNA1 single-head pumps are designed for infrared communication (IR) with Grundfos GO Remote, while MAGNA1 twin-head pumps can also communicate via radio.

In order to communicate with Grundfos GO Remote via infrared, you need an add-on module. Various Grundfos GO variants are available. The variants are described in the following.

MI 204

MI 204 is an add-on module with built-in infrared and radio communication. You can use MI 204 in conjunction with an Apple iPhone or iPod with Lightning connector, e.g. a fifth generation iPhone or iPod.



Fig. 27 MI 204

Supplied with the product:

- Grundfos MI 204
- sleeve
- quick guide
- charger cable.

TM05 7704 1513

MI 301

MI 301 is a module with built-in infrared and radio communication. Use MI 301 in conjunction with an Android or iOS-based smart device with a Bluetooth connection. MI 301 has a rechargeable Li-ion battery and must be charged separately.



TM05 3890 1712

Fig. 28 MI 301

Supplied with the product:

- Grundfos MI 301
- battery charger
- quick guide.

Product numbers

Grundfos GO variant	Product number
Grundfos MI 204	98424092
Grundfos MI 301	98046408

Pipe connection

Thread-thread adapters

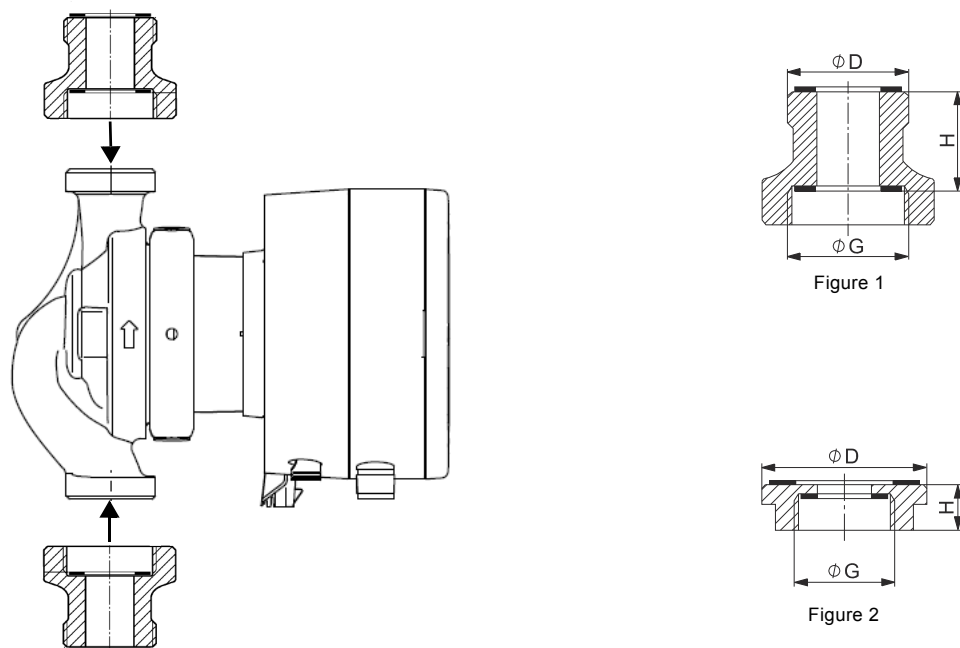
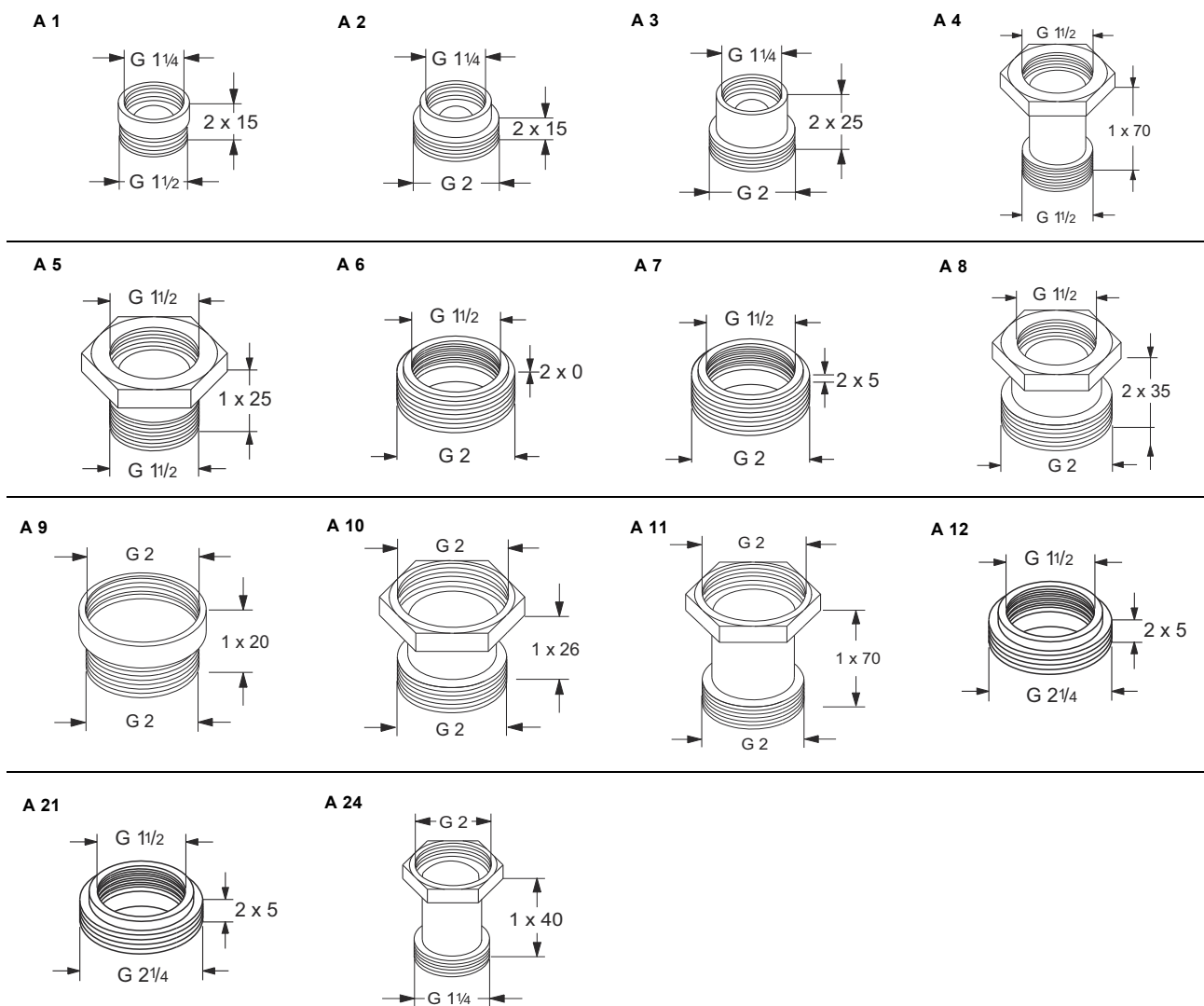

Fig. 29 Example of thread-thread adapters

TM05 8617 2513 - TM05 8618 2513

New pump Connection G	Union nut Connection D	Adapter length H [mm]	Adapter type	Figure	Material	Product number PN 10
G 1 1/4	G 1 1/4	1 x 40	A 24 G	1	Brass (Ms)	96436559
	G 1 1/4	2 x 15	A 1	1	Bronze (Rg)	535040
	G 2	2 x 15	A 2	1	Bronze (Rg)	535041
	G 2	2 x 25	A 3	1	Bronze (Rg)	535042
G 1 1/2	G 1 1/2	1 x 70	A 4	1	Cast iron (GG)	535043
	G 1 1/2	1 x 25	A 5	1	Cast iron (GG)	535044
	G 2	2 x 0	A 6	2	Brass (Ms)	535045
	G 2	2 x 5	A 7	2	Bronze (Rg)	535046
	G 2	2 x 35	A 8	1	Cast iron (GG)	535047
	G 2 1/4	2 x 5	A 21	2	Brass (Ms)	535114
	G 2	1 x 20	A 9	1	Bronze (Rg)	535048
G 2	G 2	1 x 26	A 10	1	Cast iron (GG)	535049
	G 2	1 x 70	A 11	1	Cast iron (GG)	535050

Thread types



G-threads have a cylindrical form in accordance with the EN-ISO 228-1 standard. R-threads have a conical form in accordance with the ISO 7-1 standard. In the case of a thread of size 1 1/2 inch, the threads are specified as G 1 1/2 or R 1 1/2. You can only screw male G-threads (cylindrical) into female G-threads. You can screw male R-threads (conical) into female G- or R-threads. See fig. 30.

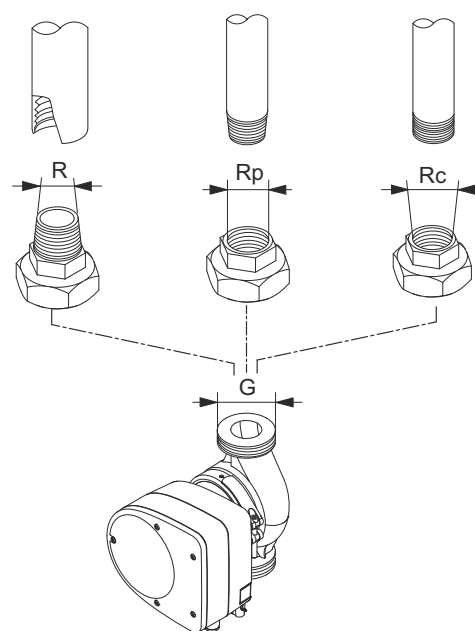

Fig. 30 G-thread and R-thread

TM060438 0214

Thread-flange adapters

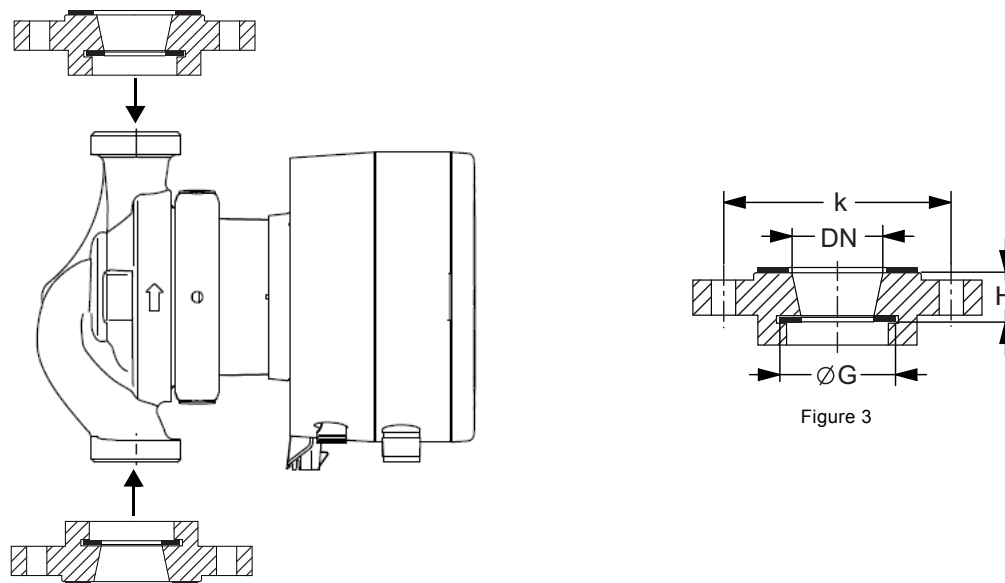

Fig. 31 Example of thread-flange adapters

TMD6 0450 0214

New pump connection	Flange connection	Adapter length H [mm]	k [mm]	Adapter type	Figure	Material	Product number PN 6	Product number PN 10
G 1 1/4	DN 32	2 x 25	90	A 13	3	Bronze (Rg)	535052	
	DN 32*	2 x 0	90	A 16	3	Cast iron (GG)	535055	
G 1 1/2	DN 32	2 x 20	90	A 14	3	Cast iron (GG)	535053	
	DN 40	2 x 20	100	A 17	3	Cast iron (GG)	535056	
	DN 50	1 x 20	110	A 19	3	Cast iron (GG)	535058	
G 2	DN 32*	1 x 10	90	A 22	3	Cast iron (GG)	535115	
	DN 32	2 x 10	100	A 28	3	Cast iron (GG)		96580074
	DN 32	2 x 20	90	A 15	3	Cast iron (GG)	535054	
	DN 40	2 x 20	100	A 18	3	Cast iron (GG)	98614387	
	DN 50	2 x 20	110	A 20	3	Cast iron (GG)	98614411	
Oval flange	Rp 1	1 x 27.5	80	A 12	3	Brass (Ms)		535051

* Grundfos square flange

A 12

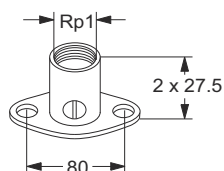

A 13

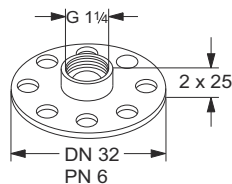

A 14

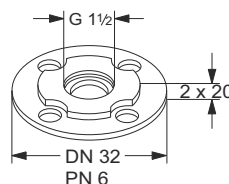

A 15

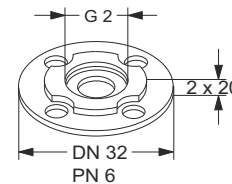

A 16

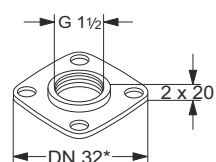

A 17

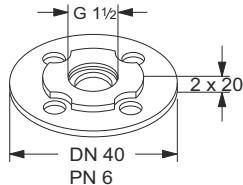

A 18

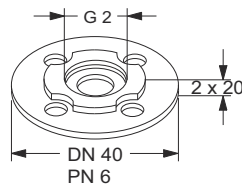

A 19

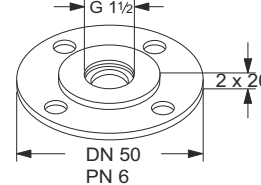

A 20

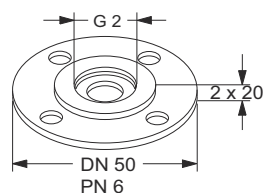

A 22

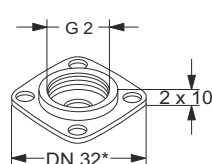

A 28

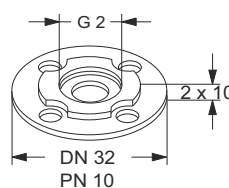

Flange-flange adapters

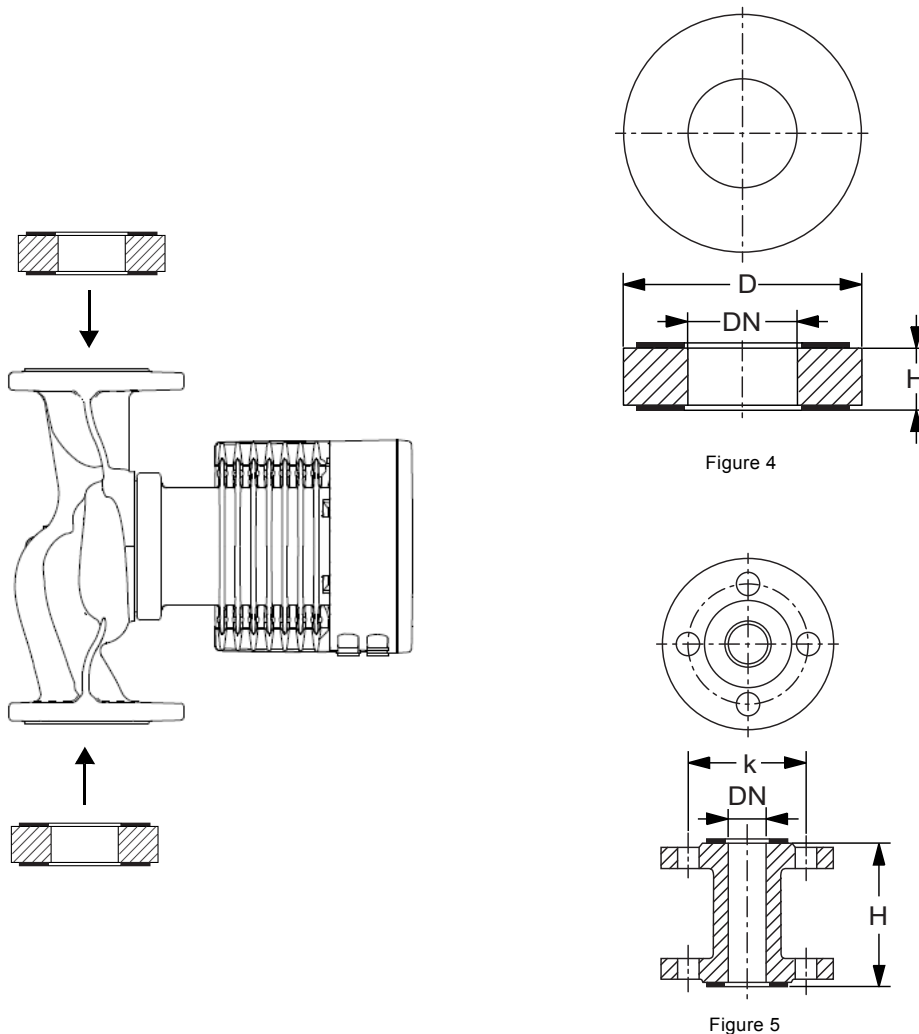
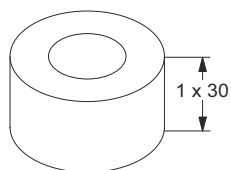

Fig. 32 Example of flange-flange adapter

New pump connection	Adapter length H [mm]	k [mm] PN 6	k [mm] PN 10	D [mm] PN 6	D [mm] PN 10	Adapter type	Figure	Material	Product number PN 6	Product number PN 10
DN 40	1 x 70	100	110			A 40-70	5	Cast iron (GG)	539921	539721
	1 x 30			82	88	A 40-30	4	Steel (St)	96281076	96608515
	1 x 10			90	102	A 50-10	4	Cast iron (GG)	549921	549821
DN 50	1 x 20			90	102	A 50-20	4	Cast iron (GG)	549922	549822
	1 x 40			90	102	A 50-40	4	Steel (St)	96281077	96608516
	1 x 50			90	102	A 50-50	4	Cast iron (GG)	549923	549823
	1 x 60	110	125			A 50-60	5	Cast iron (GG)	549924	549824
DN 65	1 x 10			110	122	A 65-10	4	Cast iron (GG)	559921	559821
	1 x 25			110	122	A 65-25	4	Cast iron (GG)	559922	559822
	1 x 160	130	145			A 65-160	5	Steel (St)	559923	559823
DN 80	1 x 10			127	138	A 80-10	4	Cast iron (GG)	569921	569821
	1 x 15			127	138	A 80-15	4	Cast iron (GG)	569922	569822
	1 x 20			127	138	A 80-20	4	Cast iron (GG)	569923	569823
	1 x 25			127	138	A 80-25	4	Cast iron (GG)	569924	569824
	1 x 40			127	138	A 80-40	4	Cast iron (GG)	569925	569825
	1 x 50			127	138	A 80-50	4	Cast iron (GG)	569926	569826
DN 100	1 x 140	150	165			A 80-140	5	Steel (St)	569927	569827
	2 x 23				106	A 100-50	4	Steel (St)		96555529

TM06 0449 0214 - TM06 0451 0214

A 40-30



A 40-70

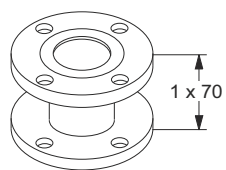

A 50-10

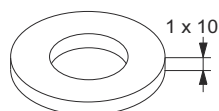

A 50-20

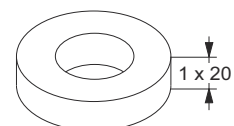

A 50-40

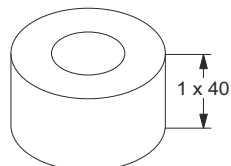

A 50-50

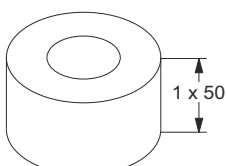

A 50-60

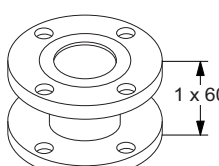

A 65-10

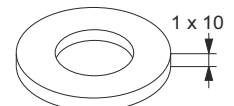

A 65-25

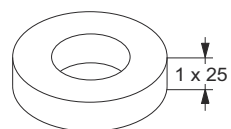

A 65-160

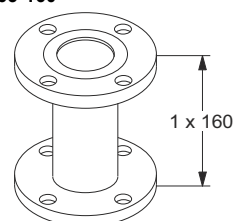

A 80-10

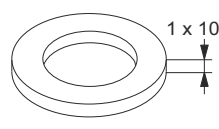

A 80-15

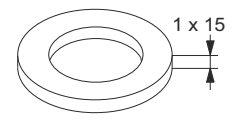

A 80-20

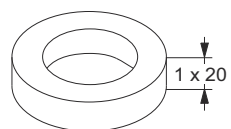

A 80-25

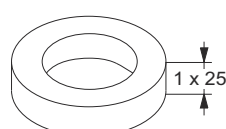

A 80-40

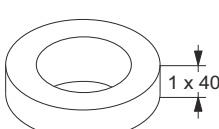

A 80-50

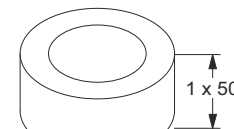

A 80-140

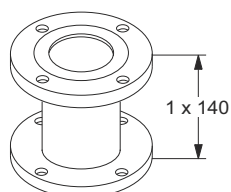

A 100-50

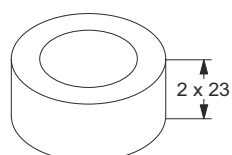

9. Product numbers

MAGNA1 for the international market

Single-head pumps

Pump type	Port-to-port length [mm]	Threaded pipe connection			Data sheet, page
		Cast iron		Stainless steel	
		PN 10	PN 16	PN 10	
MAGNA1 25-40 (N)	180	99221216	99224453	99221223	24
MAGNA1 25-60 (N)	180	99221217	99224454	99221224	25
MAGNA1 25-80 (N)	180	99221213	99224455	99221225	28
MAGNA1 25-100 (N)	180	99221214	99224456	99221226	29
MAGNA1 25-120 (N)	180	99221215	99224457	99221227	30
MAGNA1 32-40 (N)	180	99221233	99224458	99221253	31
MAGNA1 32-60 (N)	180	99221234	99224459	99221254	33
MAGNA1 32-80 (N)	180	99221235	99224460	99221255	35
MAGNA1 32-100 (N)	180	99221236	99224461	99221256	37
MAGNA1 32-120 (N)	180	99221281	99224611	99221283	39

Pump type	Port-to-port length [mm]	Flange connection					Data sheet, page
		Cast iron				Stainless steel	
		PN 6	PN 10	PN 16	PN 6/10	PN 6/10	
MAGNA1 32-40 F (N)	220			99224598	99221263	99221265	31
MAGNA1 32-60 F (N)	220			99224602	99221269	99221271	33
MAGNA1 32-80 F (N)	220			99224606	99221275	99221277	35
MAGNA1 32-100 F (N)	220			99224462	99221237	99221257	37
MAGNA1 32-120 F (N)	220			99224463	99221285	99221289	48
MAGNA1 40-40 F (N)	220			99224464	99221291	99221299	50
MAGNA1 40-60 F (N)	220			99224465	99221292	99221300	52
MAGNA1 40-80 F (N)	220			99224466	99221303	99221323	54
MAGNA1 40-100 F (N)	220			99224467	99221304	99221324	56
MAGNA1 40-120 F (N)	250			99224468	99221305	99221325	58
MAGNA1 40-150 F (N)	250			99224469	99221306	99221326	60
MAGNA1 40-180 F (N)	250			99224470	99221307	99221327	62
MAGNA1 50-60 F (N)	240			99224471	99221333	99221358	65
MAGNA1 50-80 F (N)	240			99224472	99221334	99221359	67
MAGNA1 50-100 F (N)	280			99224473	99221335	99221360	69
MAGNA1 50-120 F (N)	280			99224474	99221336	99221361	71
MAGNA1 50-150 F (N)	280			99224475	99221337	99221362	73
MAGNA1 50-180 F (N)	280			99224476	99221338	99221363	75
MAGNA1 65-40 F (N)	340			99224477	99221382	99221394	77
MAGNA1 65-60 F (N)	340			99224478	99221371	99221395	79
MAGNA1 65-80 F (N)	340			99224479	99221372	99221396	81
MAGNA1 65-100 F (N)	340			99224480	99221373	99221397	83
MAGNA1 65-120 F (N)	340			99224481	99221374	99221398	85
MAGNA1 65-150 F (N)	340			99224482	99221375	99221399	87
MAGNA1 80-60 F	360	99221406	99221410	99224483			90
MAGNA1 80-80 F	360	99221407	99221411	99224484			92
MAGNA1 80-100 F	360	99221408	99221412	99224485			94
MAGNA1 80-120 F	360	99221409	99221413	99224486			96
MAGNA1 100-40 F	450	99221438	99221443	99224487			98
MAGNA1 100-60 F	450	99221439	99221444	99224488			100
MAGNA1 100-80 F	450	99221440	99221445	99224489			102
MAGNA1 100-100 F	450	99221441	99221446	99224490			104
MAGNA1 100-120 F	450	99221442	99221447	99224610			106

Note: Click on a product number and go directly to the performance curve in Grundfos Product Center.

Twin-head pumps

Pump type	Port-to-port length [mm]	Threaded pipe connection				Data sheet, page
		Cast iron				
		PN 10		PN 16		
MAGNA1 D 32-40	180	99221238		99224491		32
MAGNA1 D 32-60	180	99221239		99224492		34
MAGNA1 D 32-80	180	99221240		99224493		36
MAGNA1 D 32-100	180	99221241		99224494		38

Pump type	Port-to-port length [mm]	Flange connection				Data sheet, page
		Cast iron				
		PN 6	PN 10	PN 16	PN 6/10	
MAGNA1 D 32-40 F	220			99224600	99221267	41
MAGNA1 D 32-60 F	220			99224604	99221273	43
MAGNA1 D 32-80 F	220			99224608	99221279	45
MAGNA1 D 32-100 F	220			99224495	99221242	47
MAGNA1 D 32-120 F	220			99224496	99221286	49
MAGNA1 D 40-40 F	220			99224497	99221293	51
MAGNA1 D 40-60 F	220			99224498	99221294	53
MAGNA1 D 40-80 F	220			99224499	99221308	55
MAGNA1 D 40-100 F	220			99224500	99221309	57
MAGNA1 D 40-120 F	250			99224501	99221310	59
MAGNA1 D 40-150 F	250			99224502	99221311	61
MAGNA1 D 40-180 F	250			99224503	99221312	63
MAGNA1 D 50-40 F	240			99231362	99230357	64
MAGNA1 D 50-60 F	240			99224504	99221339	66
MAGNA1 D 50-80 F	240			99224505	99221340	68
MAGNA1 D 50-100 F	280			99224506	99221341	70
MAGNA1 D 50-120 F	280			99224507	99221342	72
MAGNA1 D 50-150 F	280			99224508	99221343	74
MAGNA1 D 50-180 F	280			99224509	99221345	76
MAGNA1 D 65-40 F	340			99224510	99221376	78
MAGNA1 D 65-60 F	340			99224511	99221377	80
MAGNA1 D 65-80 F	340			99224512	99221378	82
MAGNA1 D 65-100 F	340			99224513	99221379	84
MAGNA1 D 65-120 F	340			99224514	99221380	86
MAGNA1 D 65-150 F	340			99224515	99221381	88
MAGNA1 D 80-40 F	360	99230392	99230413	99231368		89
MAGNA1 D 80-60 F	360	99221414	99221418	99224516		91
MAGNA1 D 80-80 F	360	99221415	99221419	99224517		93
MAGNA1 D 80-100 F	360	99221416	99221420	99224518		95
MAGNA1 D 80-120 F	360	99221417	99221421	99224519		97
MAGNA1 D 100-40 F	450	99221448	99221453	99224520		99
MAGNA1 D 100-60 F	450	99221449	99221454	99224521		101
MAGNA1 D 100-80 F	450	99221450	99221455	99224522		103
MAGNA1 D 100-100 F	450	99221451	99221456	99224523		105
MAGNA1 D 100-120 F	450	99221452	99221457	99224524		107

Note: Click on a product number and go directly to the performance curve in Grundfos Product Center.

MAGNA1 for the German market

Single-head pumps

Pump type	Port-to-port length [mm]	Threaded pipe connection			Data sheet, page
		Cast iron		Stainless steel	
		PN 6/10	PN 16	PN 10	
MAGNA1 25-40 (N)	180	99221218	99224525	99221228	24
MAGNA1 25-60 (N)	180	99221219	99224526	99221229	25
MAGNA1 25-80 (N)	180	99221220	99224527	99221230	28
MAGNA1 25-100 (N)	180	99221221	99224528	99221231	29
MAGNA1 25-120 (N)	180	99221222	99224529	99221232	30
MAGNA1 32-40 (N)	180	99221243	99224530	99221258	31
MAGNA1 32-60 (N)	180	99221244	99224531	99221259	33
MAGNA1 32-80 (N)	180	99221245	99224532	99221260	35
MAGNA1 32-100 (N)	180	99221246	99224533	99221261	37
MAGNA1 32-120 (N)	180	99221282	99224612	99221284	39

Pump type	Port-to-port length [mm]	Flange connection					Data sheet, page
		Cast iron				Stainless steel	
		PN 6	PN 10	PN 16	PN 6/10	PN 6/10	
MAGNA1 32-40 F (N)	220			99224599	99221264	99221266	40
MAGNA1 32-60 F (N)	220			99224603	99221270	99221272	42
MAGNA1 32-80 F (N)	220			99224607	99221276	99221278	44
MAGNA1 32-100 F (N)	220			99224534	99221247	99221262	46
MAGNA1 32-120 F (N)	220			99224535	99221287	99221290	48
MAGNA1 40-40 F (N)	220			99224536	99221295	99221301	50
MAGNA1 40-60 F (N)	220			99224537	99221296	99221302	52
MAGNA1 40-80 F (N)	220			99224538	99221313	99221328	54
MAGNA1 40-100 F (N)	220			99224539	99221314	99221329	56
MAGNA1 40-120 F (N)	250			99224540	99221315	99221330	58
MAGNA1 40-150 F (N)	250			99224541	99221316	99221331	60
MAGNA1 40-180 F (N)	250			99224542	99221317	99221332	62
MAGNA1 50-60 F (N)	240			99224543	99221346	99221364	65
MAGNA1 50-80 F (N)	240			99224544	99221347	99221365	67
MAGNA1 50-100 F (N)	280			99224545	99221348	99221366	69
MAGNA1 50-120 F (N)	280			99224546	99221349	99221367	71
MAGNA1 50-150 F (N)	280			99224547	99221350	99221368	73
MAGNA1 50-180 F (N)	280			99224548	99221351	99221369	75
MAGNA1 65-40 F (N)	340			99224549	99221370	99221400	77
MAGNA1 65-60 F (N)	340			99224550	99221383	99221401	79
MAGNA1 65-80 F (N)	340			99224551	99221384	99221402	81
MAGNA1 65-100 F (N)	340			99224552	99221385	99221403	83
MAGNA1 65-120 F (N)	340			99224553	99221386	99221404	85
MAGNA1 65-150 F (N)	340			99224554	99221387	99221405	87
MAGNA1 80-60 F	360	99221422	99221426	99224555			90
MAGNA1 80-80 F	360	99221423	99221427	99224556			92
MAGNA1 80-100 F	360	99221424	99221428	99224557			94
MAGNA1 80-120 F	360	99221425	99221429	99224558			96
MAGNA1 100-40 F	450	99221458	99221463	99224559			98
MAGNA1 100-60 F	450	99221459	99221464	99224560			100
MAGNA1 100-80 F	450	99221460	99221465	99224561			102
MAGNA1 100-100 F	450	99221461	99221466	99224562			104
MAGNA1 100-120 F	450	99221462	99221467	99224563			106

Note: Click on a product number and go directly to the performance curve in Grundfos Product Center.

Twin-head pumps

Pump type	Port-to-port length [mm]	Threaded pipe connection				Data sheet, page
		Cast iron				
		PN 10		PN 16		
MAGNA1 D 32-40	180	99221248		99224564		32
MAGNA1 D 32-60	180	99221249		99224565		34
MAGNA1 D 32-80	180	99221250		99224566		36
MAGNA1 D 32-100	180	99221251		99224567		38

Pump type	Port-to-port length [mm]	Flange connection				Data sheet, page
		Cast iron				
		PN 6	PN 10	PN 16	PN 6/10	
MAGNA1 D 32-40 F	220			99224601	99221268	41
MAGNA1 D 32-60 F	220			99224605	99221274	43
MAGNA1 D 32-80 F	220			99224609	99221280	45
MAGNA1 D 32-100 F	220			99224568	99221252	47
MAGNA1 D 32-120 F	220			99224569	99221288	49
MAGNA1 D 40-40 F	220			99224570	99221297	51
MAGNA1 D 40-60 F	220			99224571	99221298	53
MAGNA1 D 40-80 F	220			99224572	99221318	55
MAGNA1 D 40-100 F	220			99224573	99221319	57
MAGNA1 D 40-120 F	250			99224574	99221320	59
MAGNA1 D 40-150 F	250			99224575	99221321	61
MAGNA1 D 40-180 F	250			99224576	99221322	63
MAGNA1 D 50-40 F	240			99231366	99230389	64
MAGNA1 D 50-60 F	240			99224577	99221352	66
MAGNA1 D 50-80 F	240			99224578	99221353	68
MAGNA1 D 50-100 F	280			99224579	99221354	70
MAGNA1 D 50-120 F	280			99224580	99221355	72
MAGNA1 D 50-150 F	280			99224581	99221356	74
MAGNA1 D 50-180 F	280			99224582	99221357	76
MAGNA1 D 65-40 F	340			99224583	99221388	78
MAGNA1 D 65-60 F	340			99224584	99221389	80
MAGNA1 D 65-80 F	340			99224585	99221390	82
MAGNA1 D 65-100 F	340			99224586	99221391	84
MAGNA1 D 65-120 F	340			99224587	99221392	86
MAGNA1 D 65-150 F	340			99224588	99221393	88
MAGNA1 D 80-40 F	360	99230415	99230416	99231369		89
MAGNA1 D 80-60 F	360	99221430	99221434	99224589		91
MAGNA1 D 80-80 F	360	99221431	99221435	99224590		93
MAGNA1 D 80-100 F	360	99221432	99221436	99224591		95
MAGNA1 D 80-120 F	360	99221433	99221437	99224592		97
MAGNA1 D 100-40 F	450	99221468	99221473	99224593		99
MAGNA1 D 100-60 F	450	99221469	99221474	99224594		101
MAGNA1 D 100-80 F	450	99221470	99221475	99224595		103
MAGNA1 D 100-100 F	450	99221471	99221476	99224596		105
MAGNA1 D 100-120 F	450	99221472	99221477	99224597		107

Note: Click on a product number and go directly to the performance curve in Grundfos Product Center.

10. Grundfos Product Center

Online search and sizing tool to help you make the right choice.

<http://product-selection.grundfos.com>

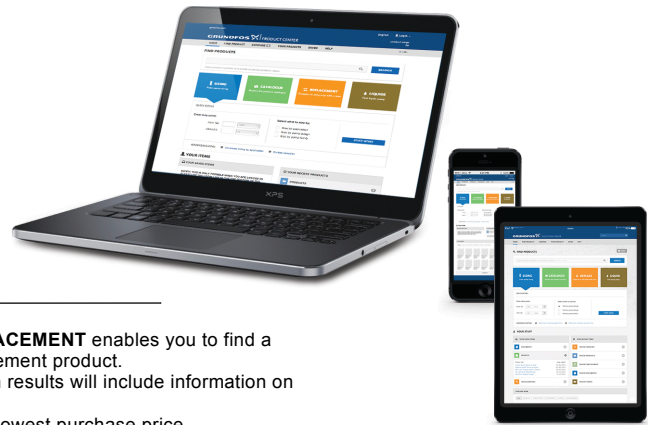

SIZING enables you to size a pump based on entered data and selection choices.

REPLACEMENT enables you to find a replacement product. Search results will include information on

- the lowest purchase price
- the lowest energy consumption
- the lowest total life cycle cost.

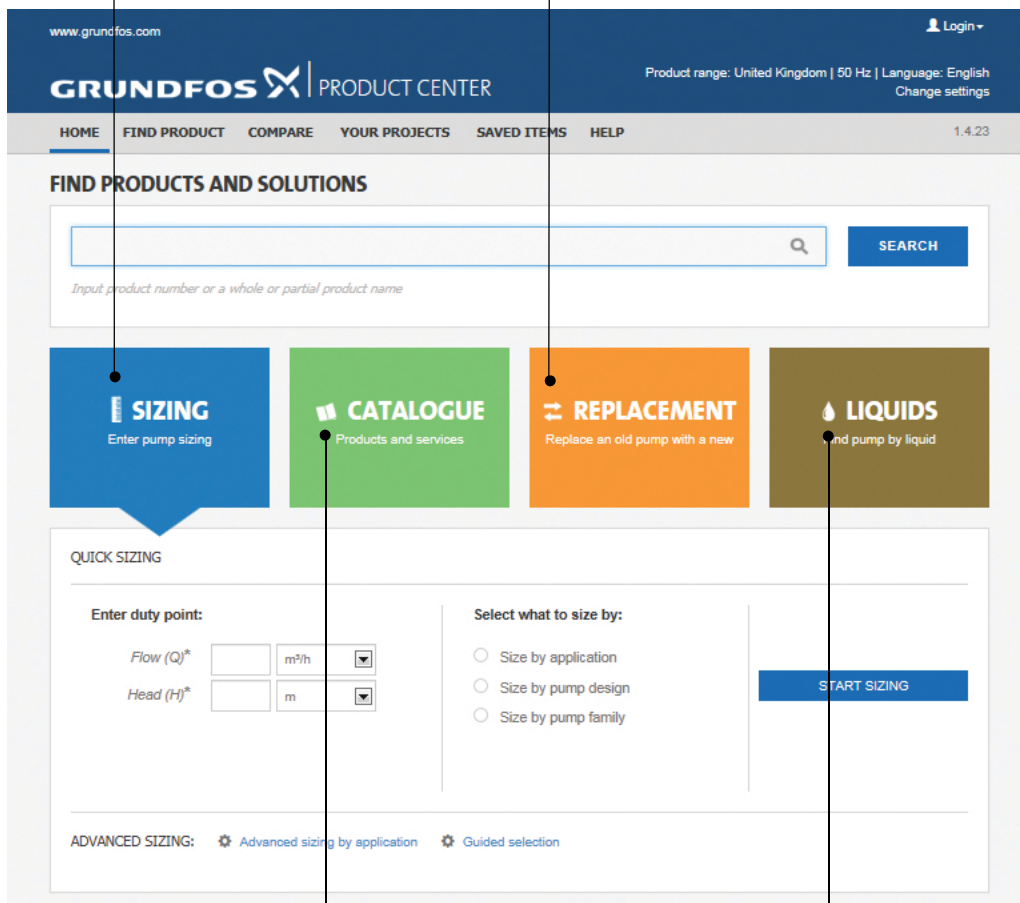

CATALOGUE gives you access to the Grundfos product catalogue.

LIQUIDS enables you to find pumps designed for aggressive, flammable or other special liquids.

All the information you need in one place

Performance curves, technical specifications, pictures, dimensional drawings, motor curves, wiring diagrams, spare parts, service kits, 3D drawings, documents, system parts. The Product Center displays any recent and saved items - including complete projects - right on the main page.

Downloads

On the product pages, you can download installation and operating instructions, data booklets, service instructions, etc. in PDF format.

be think innovate

99234565 0518

ECM: 1234258

GRUNDFOS A/S
DK-8850 Bjerringbro . Denmark
Telephone: +45 87 50 14 00
www.grundfos.com

GRUNDFOS 

The name Grundfos, the Grundfos logo, and be think innovate are registered trademarks owned by Grundfos Holding A/S or Grundfos A/S, Denmark. All rights reserved worldwide. © Copyright Grundfos Holding A/S