

Grundfos COMFORT

Circulator pumps

50/60 Hz



be
think
innovate

GRUNDFOS 

1. Product description	3
Type key	3
Approvals	3
Applications	4
Performance range	5
2. Operating conditions	6
Pumped liquids	6
Temperatures	6
Pressures	6
Pump location	6
3. Functions	7
COMFORT with AUTO _{ADAPT}	7
Temperature control mode for BT and BXT variants	9
4. Construction	10
Electrical insulation	10
Motor	10
Stator	10
Spherical separator	10
Bearing pin and bearing ball	10
Rotor	10
Pump housing	11
Isolating valve and non-return valve	11
Seal ring	11
Union nut	11
Sectional drawing	12
Material specification	12
5. Performance curves	13
Curve conditions	13
6. Data sheets	14
7. Product numbers	36
8. Accessories	37
Fittings	37
Spare parts	37
9. Grundfos Product Center	38

1. Product description

Type key

Outside USA

Example:	COMFORT	15	-14	(M)	B	(X)	(T)	(S)	(A)	PM	GB
Circulator pump											
Length 80 mm / Rp 1/2											
Maximum head [dm]											
Motor (pump head only - fits all COMFORT pump housings)											
Brass pump housing											
Integrated isolating valve and non-return valve Length 140 mm / G 1											
Temperature control											
Selectric: 3-speed											
AUTO _{ADAPT}											
Permanent magnet											
- International											
GB Great Britain											
DACH Germany, Austria, Switzerland											
CN China											

USA

Example:	COMFORT	10	-16	(T)	(A)	PM	B	5	LC
Circulator pump									
Type range									
Maximum head [dm]									
Temperature control									
AUTO _{ADAPT}									
Permanent magnet									
Brass pump housing									
5 1/2" internal sweat									
N5 1/2" NPT									
U 1 1/4" NPSM with integrated isolating valve and non-return valve									
Line cord									

Approvals



Fig. 1 European approvals

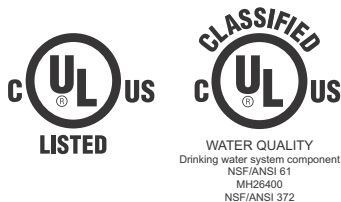

Fig. 2 US approvals

Applications

Grundfos COMFORT circulator pumps are designed for the following:

- domestic hot-water systems in single- and two-family houses
- small heating systems
- cooling and air-conditioning systems.

The pumps are suitable for open and closed systems. They must be installed indoors.

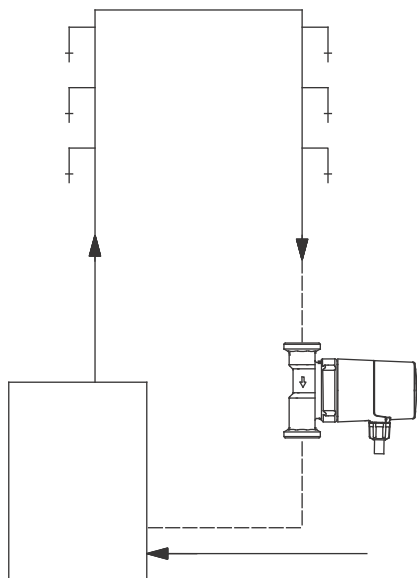

Fig. 3 Single-loop system

TM01 9110 1100

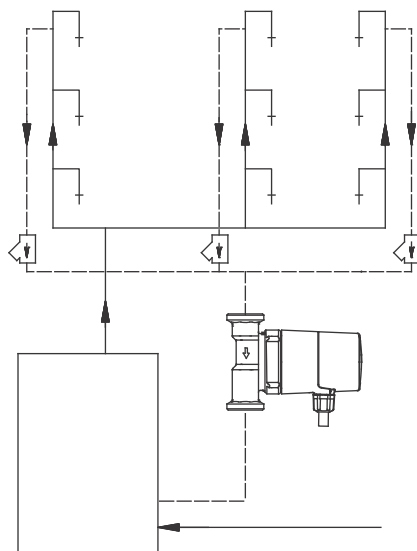

Fig. 4 Branched system

TM01 9111 1100

Domestic hot-water systems

For circulation of drinking water in domestic hot-water systems, we recommend to use Grundfos COMFORT types with brass pump housing in systems with hot-water storage tanks.

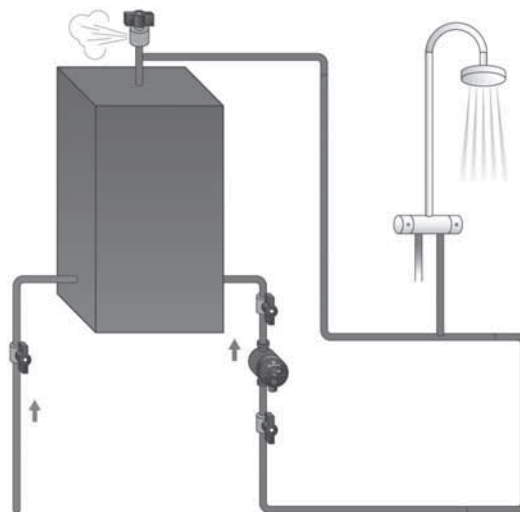

Fig. 5 Domestic hot-water system with hot-water storage tank

TM05 9316 3313

Performance range

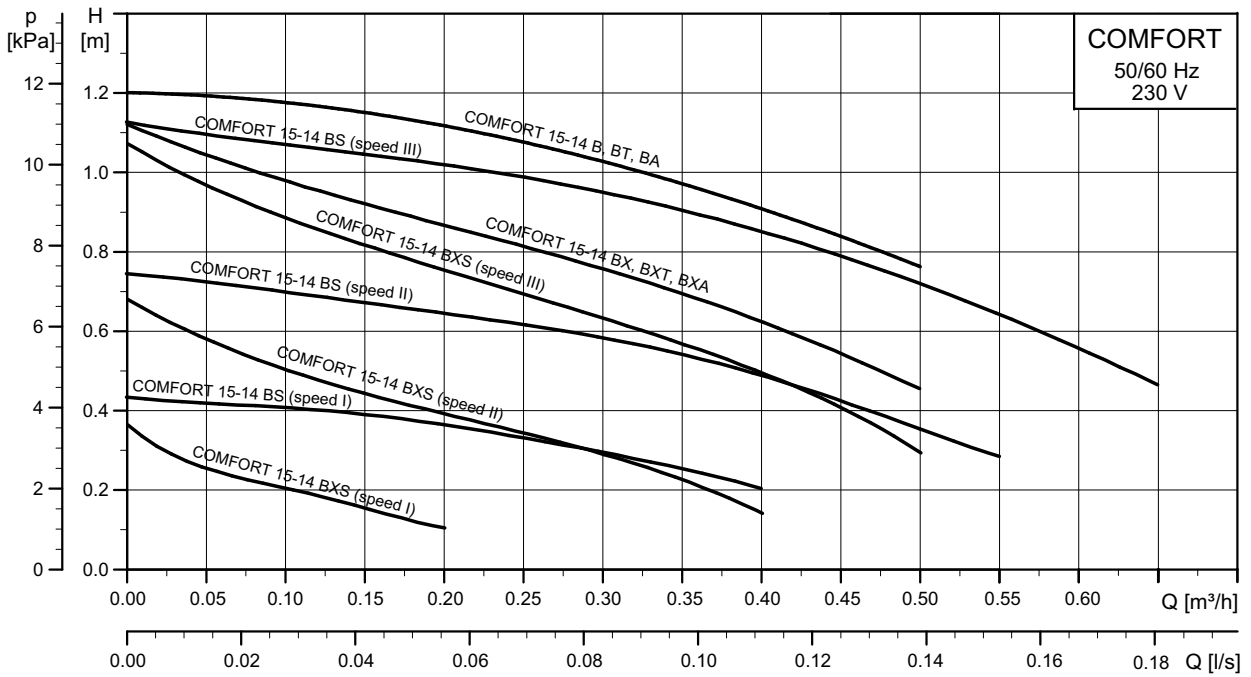

Fig. 6 COMFORT performance range (outside USA)

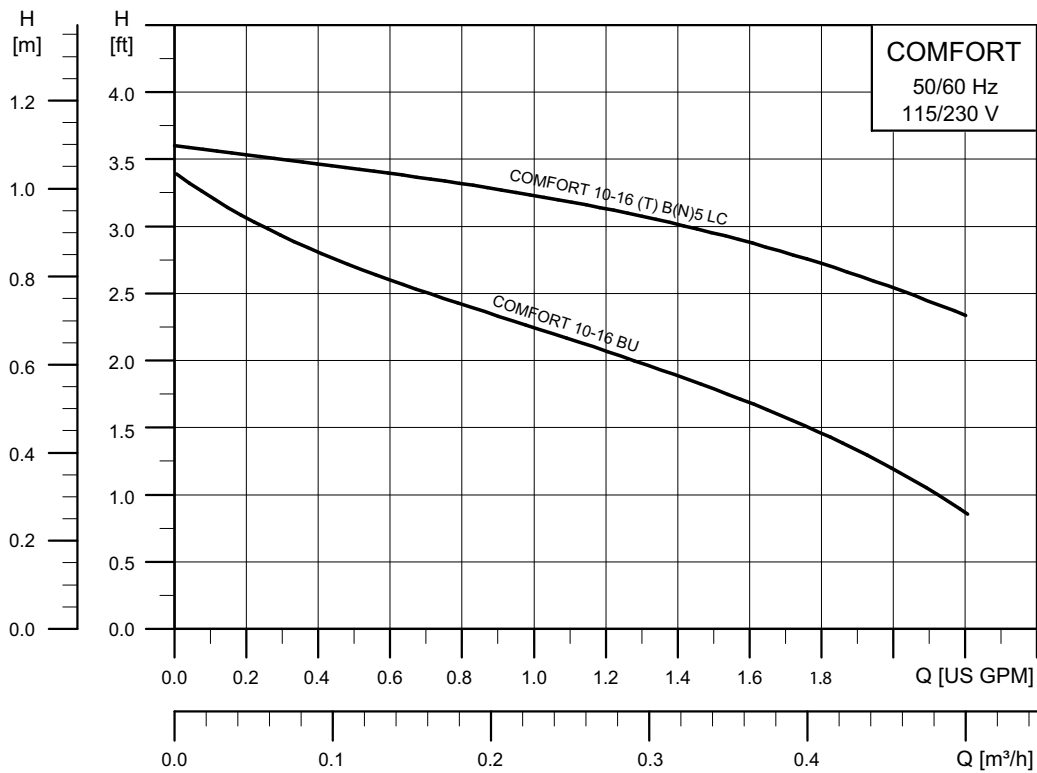

Fig. 7 COMFORT performance range USA

2. Operating conditions

Pumped liquids

- Thin, clean, non-aggressive and non-explosive liquids without solid particles or fibres
- Cooling liquids, not containing mineral oil
- Domestic hot water
- Softened water.

The kinematic viscosity of water is 1 mm²/s (1 cSt) at 20 °C. If the pump is used for a liquid with a higher viscosity, the hydraulic performance of the pump will be reduced.

Example: 50 % glycol at 20 °C means a viscosity of approx. 10 mm²/s, reducing pump performance by approx. 15 %.

When selecting a pump, the viscosity of the pumped liquid must be taken into account.

Temperatures

Liquid temperature

Liquid temperature range: 2 to 95 °C.

Operating temperature

We recommend that you keep the operating temperature around 50 °C to minimise build-up of lime deposits. Be aware of the risk of legionella contamination.

Ambient temperature

The ambient temperature must always be lower than the liquid temperature to minimise condensation in the stator housing, and not exceed 40 °C.

Pressures

System pressure

Maximum system pressure (PN 10): 1.0 MPa (10 bar/ 145 psi).

Inlet pressure

To prevent cavitation noise and damage to the pump bearing, a minimum inlet pressure of 0.5 bar (5 m head) is required at the pump suction port.

Pump location

Indoors, in a non-aggressive and non-explosive atmosphere.

Relative air humidity: Maximum 95 %.

3. Functions

COMFORT with AUTO_{ADAPT}

COMFORT BA PM and BXA PM models have the following operation modes:

- AUTO_{ADAPT} mode
- temperature control mode
- continuous 100 % mode.

AUTO_{ADAPT} mode

The AUTO_{ADAPT} function adapts the operating hours by switching on and off according to the tapping pattern of the users. This means that the pump provides maximum comfort and saves energy at the same time.

Energy-saving

The AUTO_{ADAPT} function saves energy in two ways:

- Electrical energy consumption of the pump
- Heat energy consumption of the domestic hot-water system.

The AUTO_{ADAPT} function automatically adjusts the number of operating hours, based on the hot-water consumption in the given system.

The AUTO_{ADAPT} function requires a temperature sensor to be installed on the flow pipe 20 to 50 cm from the boiler outlet. This sensor and the temperature sensor incorporated in the pump detect when hot water is tapped. The detected tapping events are logged and used to predict the consumption pattern. The AUTO_{ADAPT} function automatically controls the on/off behaviour of the pump according to this pattern. This ensures that the pump only runs when necessary, which saves both heat energy and electrical energy.

The pump needs two weeks to adapt when hot water is tapped. This means that the pump starts up in temperature mode the first two weeks even if you have selected AUTO_{ADAPT}.

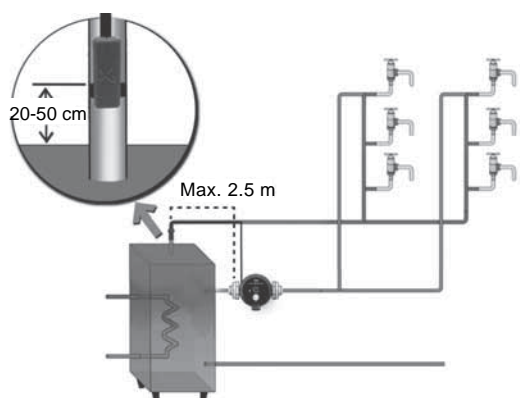

Fig. 8 COMFORT BA PM or BXA PM pump with built-in temperature sensor

TM04 9359 4010

AUTO_{ADAPT} in heating systems regulated with a thermostatic regulating valve

In systems including a thermostatic regulating valve, choose a COMFORT pump without the AUTO_{ADAPT} function.

Choosing a pump with AUTO_{ADAPT} function will result in two active regulating systems working separately, which is not recommendable.

NOTE: If a pump with AUTO_{ADAPT} function is installed in a circulation system where the temperature of the recirculated water is regulated by a thermostatic regulating valve, we recommend that you open the thermostatic regulating valve completely. This is done by setting the valve to max., which deactivates its regulating function.

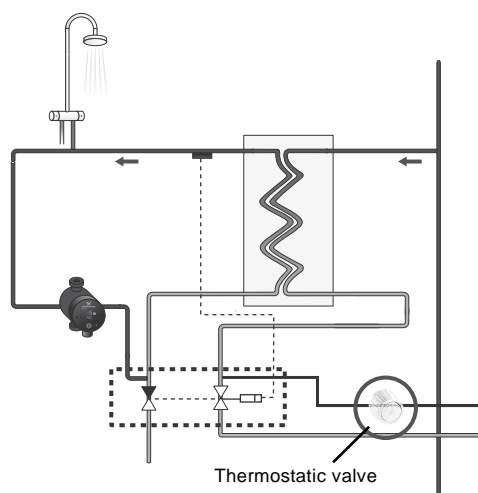

TM05 7942 1613

Fig. 9 Example of an application with thermostatic regulating valve

Control function

The control function is a combination of three parameters:

- detection of hot-water consumption
- event log function (when the demand occurs)
- pump control.

Detection of hot-water consumption

The detection of hot-water consumption is done via the temperature sensor installed in the flow pipe. The system logs the tapping events. Temperature rise caused by the pump operation is not registered in the event log.

Event log function

The AUTO_{ADAPT} function incorporates an event log that learns the scheme of demand for hot water in the domestic hot-water system. Via the event log, the pump predicts when to start circulating hot water.

The event log function stores the weekly tapping events in the system. The hot-water consumption pattern for two weeks is stored in the event log. See example.

Date	Time of day															
	00:00	00:20	00:20	00:40	----->	07:00	07:20	07:20	07:40	07:40	08:00	08:00	08:20	----->	23:30	23:50
01	0		0			0		T		0		0				0
02	0		0			0		T		T		0				0
03	0		0			0		T		0		0				0
04	0		0			0		T		0		0				0
05	0		0			0		0		T		0				T
06	0		0			0		T		0		0				0
07	0		0			0		T		0		0				0
08																
09																
10																
11																
12																
13																
14																

0: No consumption.

T: Tapping event is registered.

Example

- From 07:20 to 07:40, six tapping events (T) are registered (morning bath).
- From 07:40 to 08:00, two tapping events (T) are registered.
- From 23:30 to 23:45, one tapping event (T) is registered.

This pattern implies that hot water should be available for tapping from 07:20 to 08:00.

At 08:00 the pump can stop circulating hot water. Likewise, the pump should circulate hot water for use from 23:30 to 23:50.

The data shown is for one week of operation only. The pump stores data for two weeks. When data for two weeks has been logged, the pump is able to distinguish between the tapping pattern during workdays and weekends.

Pump control

Pump operation is based on the data stored in the event log and on the temperature of the pipes.

The pump control incorporates a temperature hysteresis, meaning that the pump ensures that the hot-water temperature is within the range of what is accepted as hot water. This temperature hysteresis control is enabled when the data content of the event log makes it probable that hot water will be tapped within the next 20 minutes.

In the example, the hysteresis control will start at 07:00 and run continuously until 08:00.

Disinfection and flushing

Once a week a disinfection function is run for 15 minutes. If, at another time of the week, a higher temperature is measured, the disinfection run will be shifted to this time.

If the pump is switched off for eight hours, it will be on to do a flushing of the circulation pipe with a duration of 15 minutes.

Fault indication

Defective external temperature sensor

If in AUTO_{ADAPT}, the red error indicator LED is on and goes off when the pump is switched manually to temperature control mode, the external temperature sensor is defective. In this case, the pump turns internally to temperature control mode, because the external temperature sensor is needed for the AUTO_{ADAPT} control mode. The display does not automatically change to temperature control mode.

Defective internal temperature sensor

If in AUTO_{ADAPT}, the red error indicator is on and doesn't go off when the pump is switched manually to temperature control mode, the internal temperature sensor is defective. In this case, the pump uses the external temperature sensor for the temperature control mode.

Temperature control mode for all AUTO_{ADAPT} (BA, BXA) variants

The regulation of the COMFORT AUTO_{ADAPT} models is based on temperature control. The operating range of the pump is kept within a calculated temperature range. This means that the pump operates in an average temperature area providing the maximum comfort and saves energy at the same time.

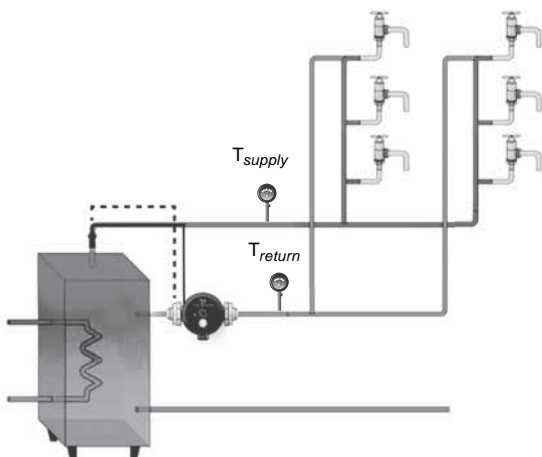

TM06 0947 1214

Fig. 10 Comfort in heat application

With temperature control, the maximum temperature measured at both sensors is stored and the pump automatically calculates the gap between T_{stop} and T_{start} . The pump switches on when one of the sensors detects a lower temperature than T_{start} . The pump switches off when the T_{stop} temperature is exceeded on both sensors.

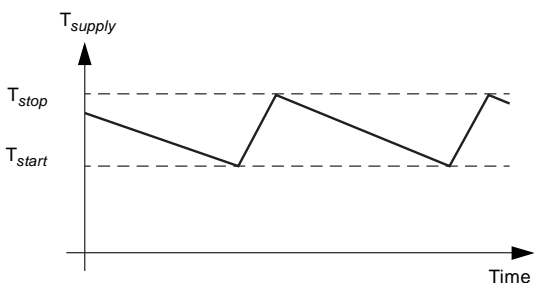

TM06 0948 1214

Fig. 11 Temperature control mode

Continuous 100 % mode

The pump is running continuously at full speed without any control.

Temperature control mode for BT and BXT variants

COMFORT PM BT and BXT variants have an integrated temperature control mode that controls the circulation. The temperature control mode switches the pump off when a preset temperature limit T_{off} is reached, and back on when a preset temperature limit T_{on} is reached.

These temperature limits are set automatically and dynamically. Manual settings are not needed.

After the first installation or after a power cut-off, the pump carries out an identification run for 10 minutes to verify the system temperature. Based on the result, T_{on} and T_{off} are calculated. The identification run is repeated every 12 hours to avoid a wrong temperature setting, for example during night setback of the water heater.

- $T_{on} = T_{sys} - 14\text{ °C}$
- $T_{off} = T_{sys} - 7\text{ °C}$

4. Construction

Grundfos COMFORT PM circulator pumps are available in various pump housing versions and lengths incorporating isolating and non-return valves or prepared for subsequent fitting of such valves.

The motor can be separated from the pump housing, enabling easy maintenance and replacement.

The rotor bearing is self-adjusting and lubricated by the pumped liquid.

The pumps have the following characteristics:

- Parts in contact with the pumped liquid are hermetically separated from the stator by a stainless-steel spherical separator.
- The bearing has no play, and as it has only a single bearing point, it generates very low friction, resulting in reduced power input and noise.

Electrical insulation

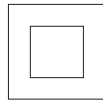

TM05 9197 2913

Fig. 12 Protection Class II symbol

All Grundfos COMFORT PM models are electrically double insulated (Protection Class II). This makes the protective earth connector obsolete.

Motor

The motor is a single-phase, 12-pole, permanent-magnet motor in conformity with the EMC directive.

The permanent-magnet motor has no rotating bearing shaft. A green indicator light on the motor is on when the motor is running.

The pump motor is impedance-protected and short-circuit-proof. No additional motor protection is required.

The terminal box is easily accessible and has functional cable connecting terminals. The cable entry is tight and incorporates cable relief.

Enclosure class: IP 44

Insulation class: F

Voltages

- Europe: 1 x 230 V, 50/60 Hz
- UK: 1 x 230 V, 50/60 Hz
- China: 1 x 230 V, 50/60 Hz
- USA: 1 x 115/230 V, 50/60 Hz

Stator

The stator generates a magnetic field acting directly on the magnetic rotor. As a result, the rotor is caused to rotate. The axial components of the magnetic field act as an attractive force on the rotor, thus stabilising it in its longitudinal axis.

Spherical separator

The stainless-steel spherical separator hermetically seals the water-conducting part of the pump from the electrically active part of the motor without any additional seal.

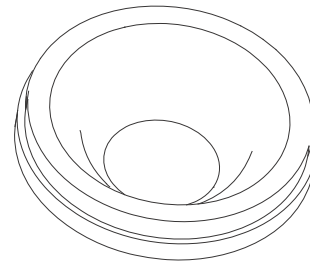

TM06 52014115

Fig. 13 Spherical separator

Bearing pin and bearing ball

The stainless-steel bearing pin is homogeneously welded by laser beam to the spherical separator and the bearing ball.



TM06 5202 4115

Fig. 14 Bearing pin

Rotor

The rotor is gimbal-mounted on the bearing ball with its own step bearing.

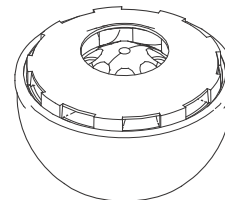

TM06 5203 4115

Fig. 15 Rotor

Pump housing

The pump housing is designed in such a way that a high hydraulic efficiency is achieved when the energy produced by the impeller is converted into pressure. The pump housing thread enables connection to standard pipe dimensions.

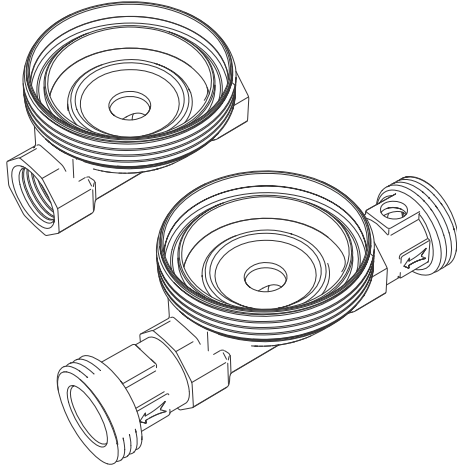

TM06 8283 5016

Fig. 16 Pump housing with and without valves

Isolating valve and non-return valve

The COMFORT pump types BX (Europe) and BU (USA) have a built-in isolating valve and a non-return valve.

The isolating valve ensures that maintenance can be carried out while the suction side is isolated.

The non-return valve isolates the discharge side during maintenance.

Seal ring

The COMFORT pump has just one seal ring between the spherical motor and the pump housing. The seal ring material is resistant to hydrolysis and ageing, thus lasting the entire pump life.

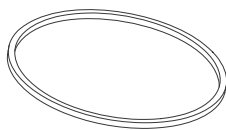

TM06 5206 4115

Fig. 17 Seal ring

Union nut

The union nut ensures that motor and pump housing are tightly connected. Thanks to the thread type, the seal ring is pressed evenly over the entire seal face.

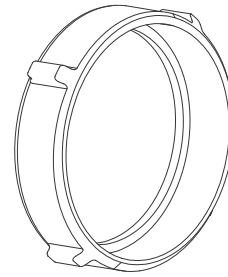
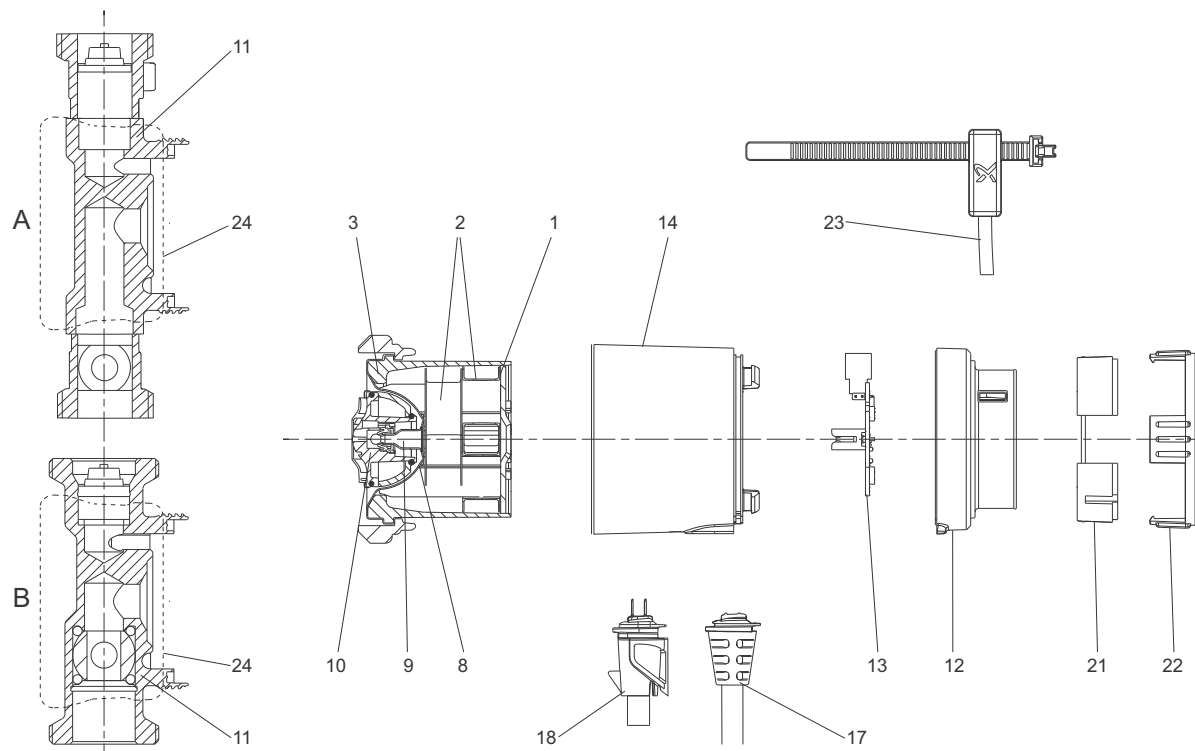

Fig. 18 Union nut

TM06 5207 4115

Sectional drawing



TM06 8303 5116

Fig. 19 Sectional drawing of COMFORT PM

Material specification

Pos.	Component	Material	EN	AISI
1	Stator lamination	Steel		
2	Stator windings	Copper wire and enamel		
3	Stator housing	Aluminium/P66		
8	Spherical separator	Stainless steel	1.4016	430
9	Rotor can, complete	Stainless steel/tungsten carbide	1.4571	316 Ti
10	Rotor, impeller	Stainless steel, EPDM, PPO, PFTE, graphite		
11	Pump housing A: Outside USA B: USA	Brass (CW617N) Brass (ECOBASS, CuZn ₂₁ Si ₃ P)	CW617N	
12	Terminal box cover	PC/ABS		
13	PC board with diode	FR 4		
14	Motor cover	PPO		
17	Cable with plug			
18	COMFORT plug (GB versions BA/BXA only)	PA66		
21	Cable ring 1 (AUTO _{ADAPT} variant only)	PC/ABS		
22	Cable ring 2 (AUTO _{ADAPT} variant only)	PC/ABS		
23	Temperature sensor (AUTO _{ADAPT} variant only)			
24	Insulation shells	EPP 55		

5. Performance curves

Curve conditions

The guidelines below apply to the performance curves on the following pages:

- Test liquid: airless water.
- The measurements for COMFORT PM have been made at a water temperature of 20 °C.
- All curves show average values and must not be used as guarantee curves. If a specific minimum performance is required, individual measurements must be made.
- The COMFORT PM curves apply to a kinematic viscosity of $\nu = 1 \text{ mm}^2/\text{s}$ (1 cSt).
- The conversion between head H [m] and pressure p [kPa] was made for water with a density of $\rho = 1000 \text{ kg/m}^3$. For liquids with other densities, for example hot water, the discharge pressure is proportional to the density.

6. Data sheets

COMFORT 15-14 B PM, 15-14 B PM DACH, 15-14 B PM CN

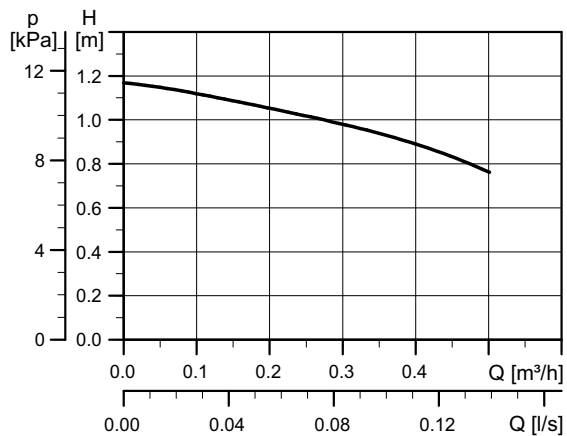

Electrical data, 1 x 230 V, 50/60 Hz

P1 [W]	I _{1/1} [A]
7	0.07

Dimensions

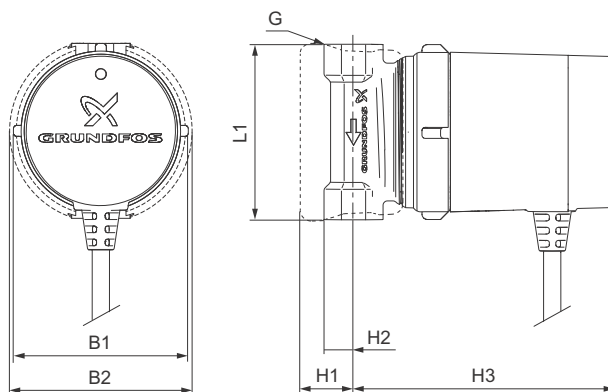

Connections: Rp 1/2. Various fittings see page 37.
 System pressure: Max. 10 bar.
 Liquid temperature: 2-95 °C (TF 95).
 IP class: IP44

TM06 8275 5016

Pump type	Dimensions [mm]							Weights [kg]		Shipping volume [m³]
	L1	H1	H2	H3	B1	B2	G	Net	Gross	
COMFORT 15-14 B PM COMFORT 15-14 B PM DACH COMFORT 15-14 B PM CN	80	25	13.5	119	79.5	84	Rp 1/2	1.00	1.12	0.0026

COMFORT 15-14 BS PM, COMFORT 15-14 BS PM DACH

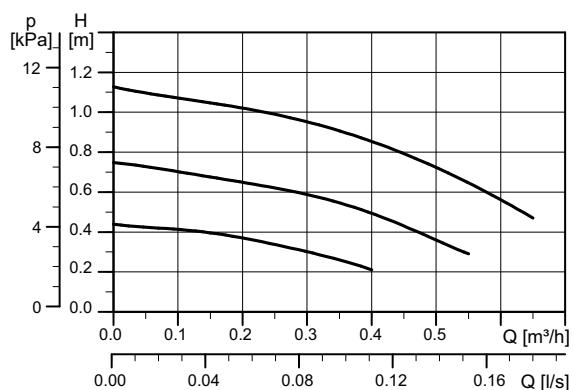

TM06 3620 0715

Electrical data, 1 x 230 V, 50/60 Hz

P1 - speed 1/2/3 [W]	I _{1/1} - speed 1/2/3 [A]
2.5 / 4 / 6	0.04 / 0.05 / 0.07

Dimensions

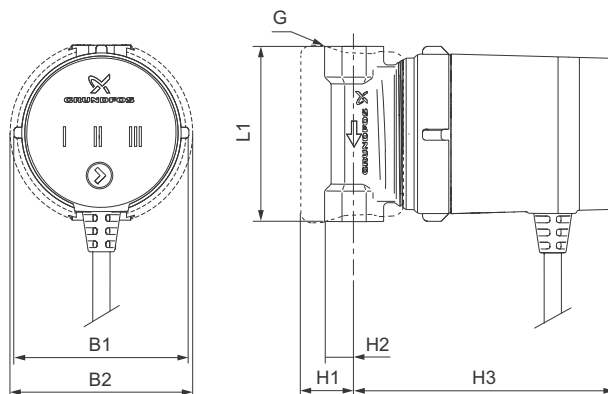

TM06 8273 5016

TM06 9446 2317

Pump type	Dimensions [mm]							Weights [kg]		Shipping volume [m ³]
	L1	H1	H2	H3	B1	B2	G	Net	Gross	
COMFORT 15-14 BS PM COMFORT 15-14 BS PM DACH	80	25	13.5	129	79.5	84	Rp 1/2	1.00	1.12	0.0026

COMFORT 15-14 BT PM, 15-14 BT PM DACH, 15-14 BT PM CN

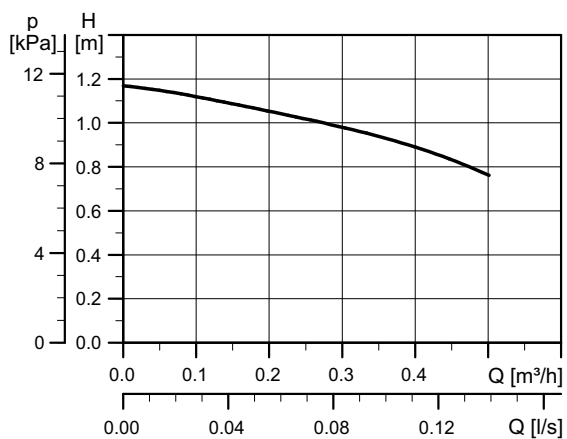

TM06 3622 0715



TM06 9246 2017

Electrical data, 1 x 230 V, 50/60 Hz

P1 [W]	I _{1/1} [A]
7	0.07

Connections: Rp 1/2. Various fittings see page 37.
 System pressure: Max. 10 bar.
 Liquid temperature: 2-95 °C (TF 95).
 IP class: IP44

Dimensions

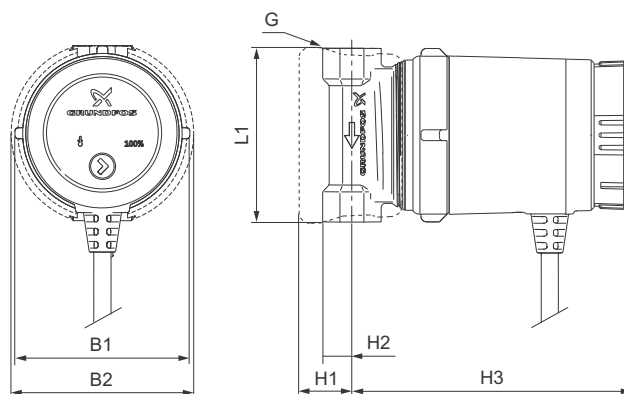

TM06 9251 2017

Pump type	Dimensions [mm]							Weights [kg]		Shipping volume [m ³]
	L1	H1	H2	H3	B1	B2	G	Net	Gross	
COMFORT 15-14 BT PM COMFORT 15-14 BT PM DACH COMFORT 15-14 BT PM CN	80	25	13.5	129	79.5	84	Rp 1/2	1.00	1.12	0.0026

COMFORT 15-14 BA PM, 15-14 BA PM DACH, 15-14 BA PM CN

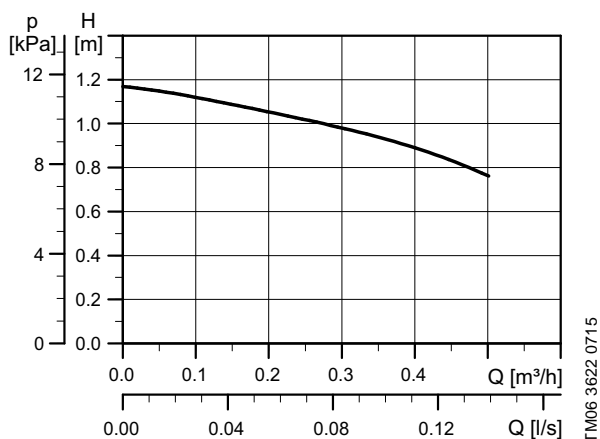

TM06 8274 5016

Electrical data, 1 x 230 V, 50/60 Hz

P1 [W]	I _{1/1} [A]
7	0.07

Connections: Rp 1/2. Various fittings see page 37.
 System pressure: Max. 10 bar.
 Liquid temperature: 2-95 °C (TF 95).
 IP class: IP44

Dimensions

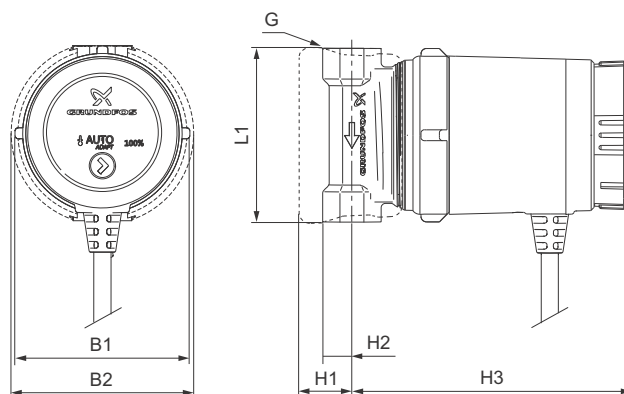

TM06 9258 2117

Pump type	Dimensions [mm]							Weights [kg]		Shipping volume [m³]
	L1	H1	H2	H3	B1	B2	G	Net	Gross	
COMFORT 15-14 BA PM COMFORT 15-14 BA PM DACH COMFORT 15-14 BA PM CN	80	25	13.5	129	79.5	84	Rp 1/2	1.00	1.12	0.0026

COMFORT 15-14 BX PM, COMFORT 15-14 BX PM DACH

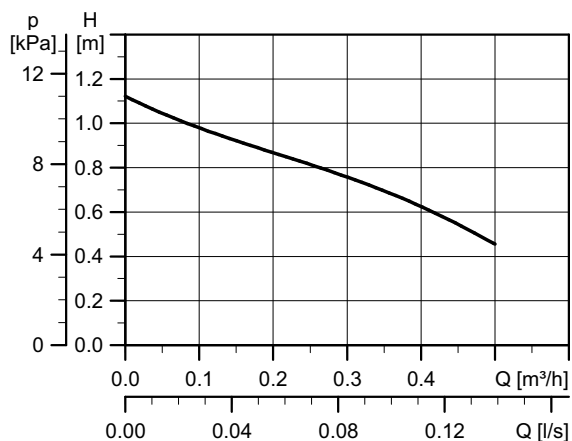

Electrical data, 1 x 230 V, 50/60 Hz

P1 [W]	I _{1/1} [A]
7	0.07

Connections: G 1
 System pressure: Max. 10 bar.
 Liquid temperature: 2-95 °C (TF 95).
 IP class: IP44

Dimensions

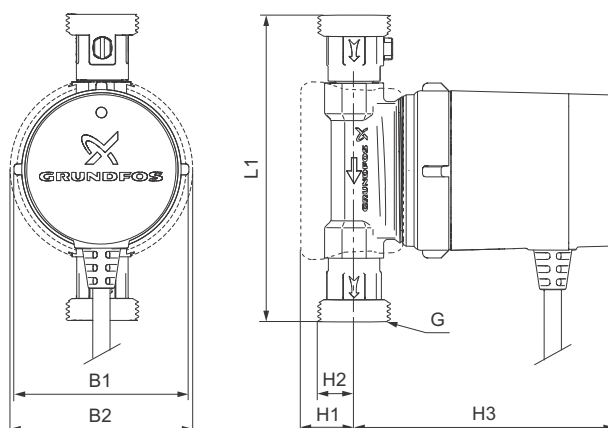

Pump type	Dimensions [mm]							Weights [kg]		Shipping volume [m ³]
	L1	H1	H2	H3	B1	B2	G	Net	Gross	
COMFORT 15-14 BX PM	140	25	21	119	79.5	84	G 1	1.35	1.51	0.0034
COMFORT 15-14 BX PM DACH										

COMFORT 15-14 BXS PM, COMFORT 15-14 BXS PM DACH

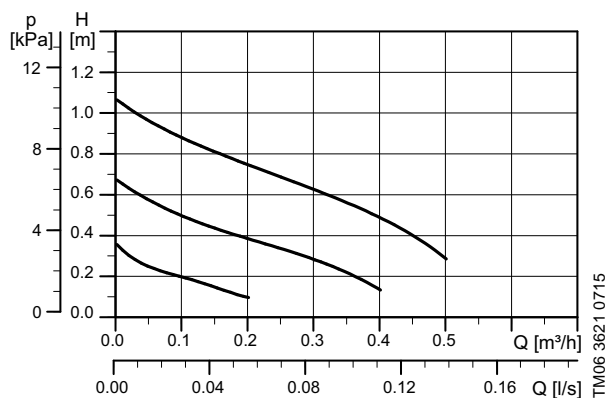

Electrical data, 1 x 230 V, 50/60 Hz

P1 - speed 1/2/3 [W]	I _{1/1} - speed 1/2/3 [A]
2.5 / 4 / 6	0.04 / 0.05 / 0.07

Connections: G 1
 System pressure: Max. 10 bar.
 Liquid temperature: 2-95 °C (TF 95).
 IP class: IP44



TM06 8270 5016

Dimensions

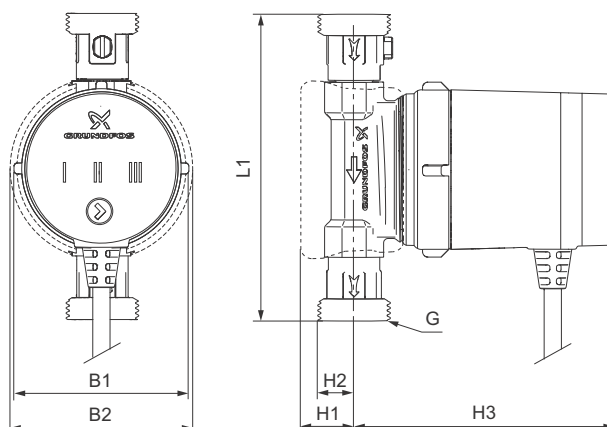

TM06 8291 5016

Pump type	Dimensions [mm]							Weights [kg]		Shipping volume [m ³]
	L1	H1	H2	H3	B1	B2	G	Net	Gross	
COMFORT 15-14 BXS PM	140	25	21	129	79.5	84	G 1	1.00	1.12	0.0026
COMFORT 15-14 BXS PM DACH										

COMFORT 15-14 BXT PM, 15-14 BXT PM DACH

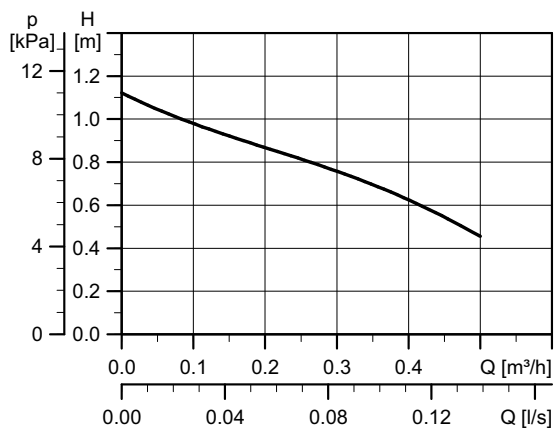

TM06 8415 0617



TM06 9247 2017

Electrical data, 1 x 230 V, 50/60 Hz

P1 [W]	I _{1/1} [A]
7	0.07

Connections: G 1
 System pressure: Max. 10 bar.
 Liquid temperature: 2-95 °C (TF 95).
 IP class: IP44

Dimensions

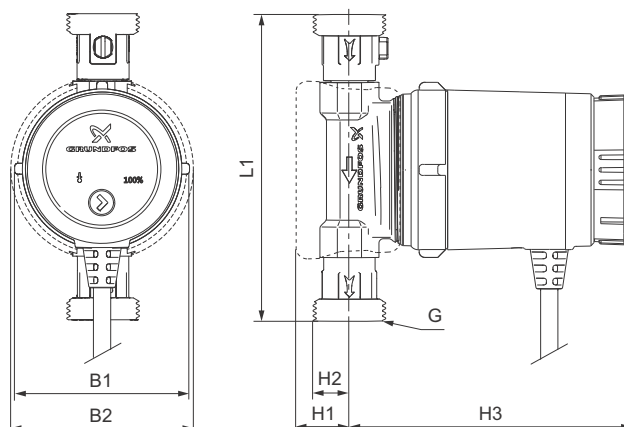

TM06 9252 2017

Pump type	Dimensions [mm]							Weights [kg]		Shipping volume [m³]
	L1	H1	H2	H3	B1	B2	G	Net	Gross	
COMFORT 15-14 BXT PM COMFORT 15-14 BXT PM DACH	140	25	21	129	79.5	84	G 1	1.35	1.51	0.0034

COMFORT 15-14 BXA PM, 15-14 BXA PM DACH

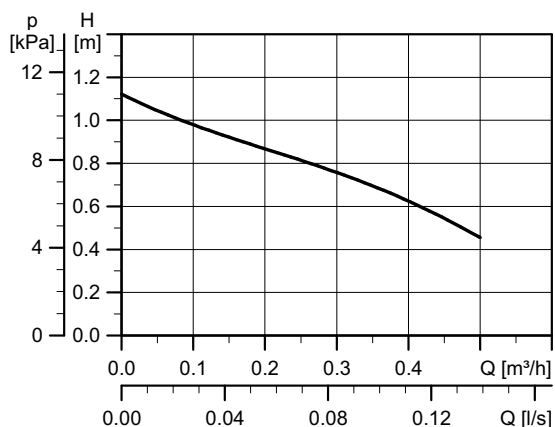

TM06 8415 0617



TM06 8271 5016

Electrical data, 1 x 230 V, 50/60 Hz

P1 [W]	I _{1/1} [A]
7	0.07

Connections: G 1
 System pressure: Max. 10 bar.
 Liquid temperature: 2-95 °C (TF 95).
 IP class: IP44

Dimensions

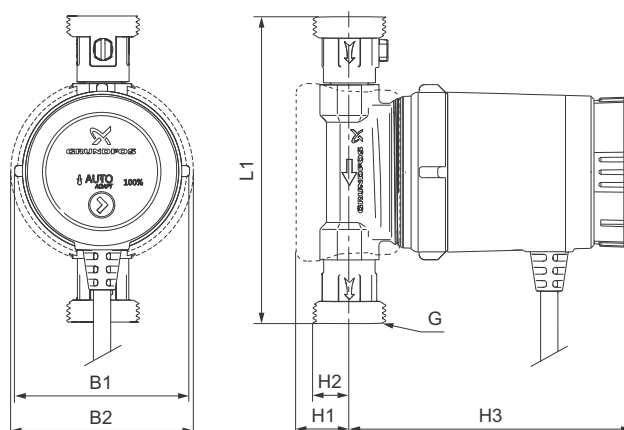

TM06 8290 5016

Pump type	Dimensions [mm]							Weights [kg]		Shipping volume [m ³]
	L1	H1	H2	H3	B1	B2	G	Net	Gross	
COMFORT 15-14 BXA PM	140	25	21	129	79.5	84	G 1	1.35	1.51	0.0034
COMFORT 15-14 BXA PM DACH										

COMFORT 15-14 MBS PM DACH

Note:

- Performance curve for pump housing without fittings, see COMFORT 15-14 BS PM, COMFORT 15-14 BS PM DACH on page 15.
- Performance curve for pump housing with fittings, see COMFORT 15-14 BXS PM, COMFORT 15-14 BXS PM DACH on page 19.

Electrical data, 1 x 230 V, 50/60 Hz

P1 - speed 1/2/3 [W]	I _{1/1} - speed 1/2/3 [A]
2.5/4/6	0.04/0.05/0.07



TM06 8263 5016

System pressure: Max. 10 bar.
 Liquid temperature: 2-95 °C (TF 95).
 IP class: IP44

Dimensions

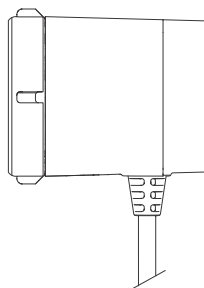
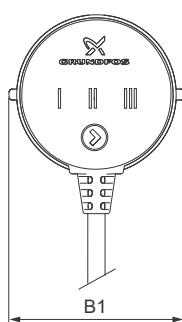

TM06 8295 5016

Pump type	Dimensions [mm]						Weights [kg]		Shipping volume [m ³]	
	L1	H1	H2	H3	B1	B2	G	Net		Gross
COMFORT 15-14 MBS PM DACH	-	-	-	-	79.5	-	-	0.43	0.44	0.0026

COMFORT 15-14 B PM GB

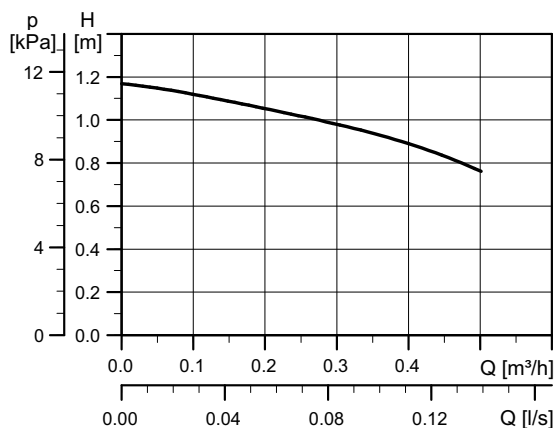

TM06 3622 0715



TM06 8269 5016

Connections: Rp 1/2. Various fittings, see page 37.
 System pressure: Max. 10 bar.
 Liquid temperature: 2-95 °C (TF 95).
 IP class: IP44

Electrical data, 1 x 230 V, 50/60 Hz

P1 [W]	I _{1/1} [A]
7	0.07

Dimensions

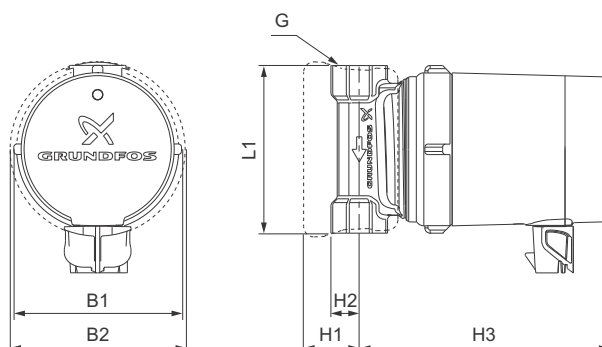

TM06 8280 5016

Pump type	Dimensions [mm]							Weights [kg]		Shipping volume [m³]
	L1	H1	H2	H3	B1	B2	G	Net	Gross	
COMFORT 15-14 B PM GB	80	25	13.5	119	79.5	84	Rp 1/2	1.00	1.12	0.0026

COMFORT 15-14 BT PM GB

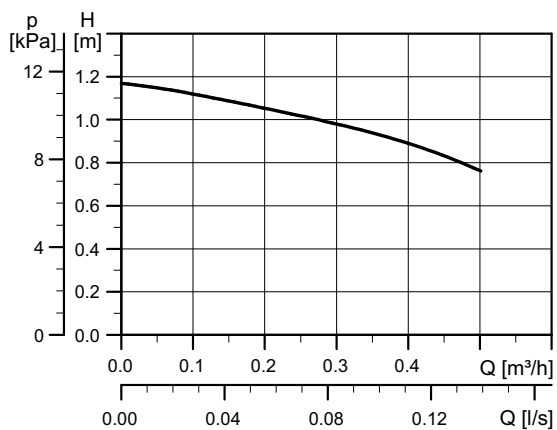

TM06 3622 0715



TM06 9248 2017

Connections: Rp 1/2. Various fittings see page 37.
 System pressure: Max. 10 bar.
 Liquid temperature: 2-95 °C (TF 95).
 IP class: IP44

Electrical data, 1 x 230 V, 50/60 Hz

P1 [W]	I _{1/1} [A]
7	0.07

Dimensions

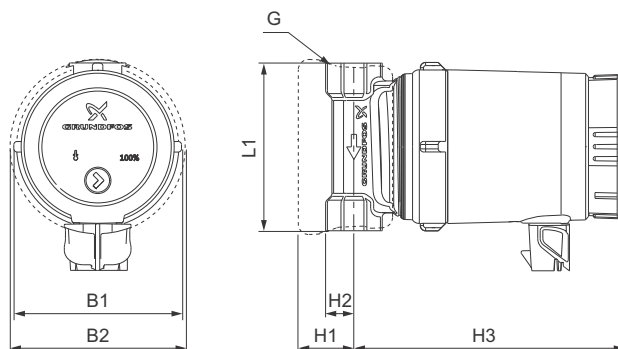

TM06 9253 2017

Pump type	Dimensions [mm]							Weights [kg]		Shipping volume [m³]
	L1	H1	H2	H3	B1	B2	G	Net	Gross	
COMFORT 15-14 BT PM GB	80	25	13.5	129	79.5	84	Rp 1/2	1.00	1.12	0.0026

COMFORT 15-14 BA PM GB

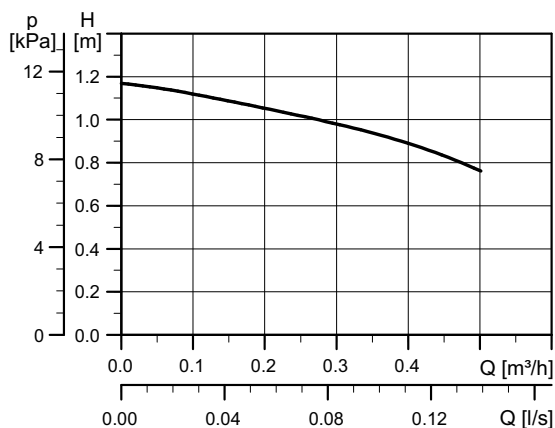

TM06 3622 0715



TM06 8268 5016

Connections: Rp 1/2. Various fittings see page 37.
 System pressure: Max. 10 bar.
 Liquid temperature: 2-95 °C (TF 95).
 IP class: IP44

Electrical data, 1 x 230 V, 50/60 Hz

P1 [W]	I _{1/1} [A]
7	0.07

Dimensions

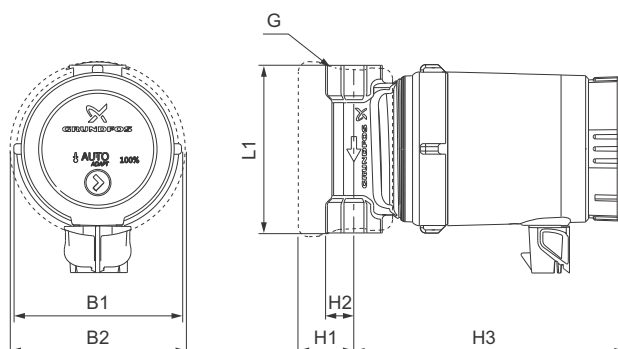

TM06 8281 5016

Pump type	Dimensions [mm]							Weights [kg]		Shipping volume [m³]
	L1	H1	H2	H3	B1	B2	G	Net	Gross	
COMFORT 15-14 BA PM GB	80	25	13.5	129	79.5	84	Rp 1/2	1.00	1.12	0.0026

COMFORT 15-14 BX PM GB

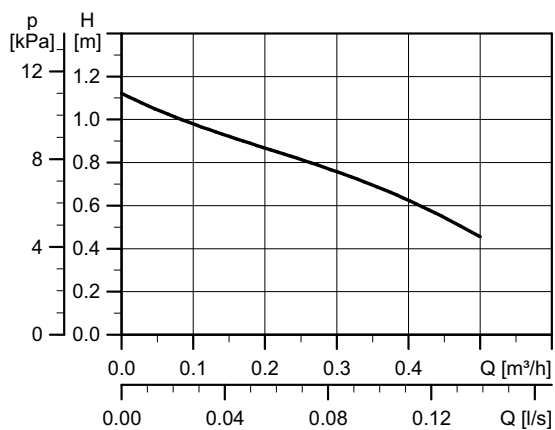

TM06 8415 0617

Electrical data, 1 x 230 V, 50/60 Hz

P1 [W]	I _{1/1} [A]
7	0.07

Dimensions

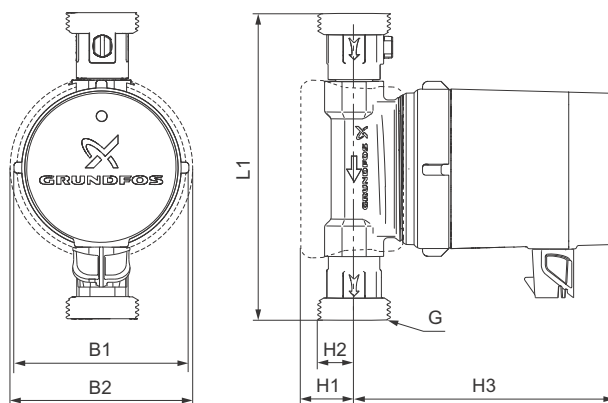

TM06 8266 5016

TM06 8297 5016

Pump type	Dimensions [mm]							Weights [kg]		Shipping volume [m³]
	L1	H1	H2	H3	B1	B2	G	Net	Gross	
COMFORT 15-14 BX PM GB	140	25	21	119	79.5	84	G 1	1.35	1.51	0.0034

COMFORT 15-14 BXT PM GB

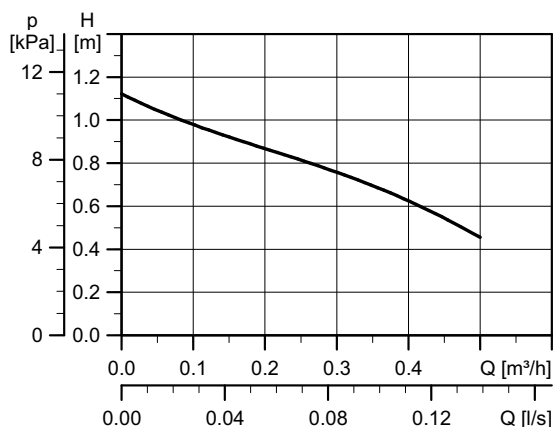

TM06 8415 0617

Electrical data, 1 x 230 V, 50/60 Hz

P1 [W]	I _{1/1} [A]
7	0.07

Dimensions

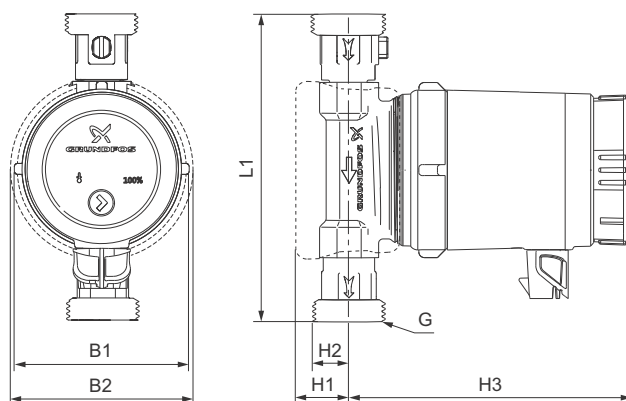

TM06 9254 2017

Connections: G 1
 System pressure: Max. 10 bar.
 Liquid temperature: 2-95 °C (TF 95).
 IP class: IP44

TM06 9249 2017

Pump type	Dimensions [mm]						Weights [kg]		Shipping volume [m³]	
	L1	H1	H2	H3	B1	B2	G	Net		Gross
COMFORT 15-14 BXT PM GB	140	25	21	129	79.5	84	G 1	1.35	1.51	0.0034

COMFORT 15-14 BXA PM GB

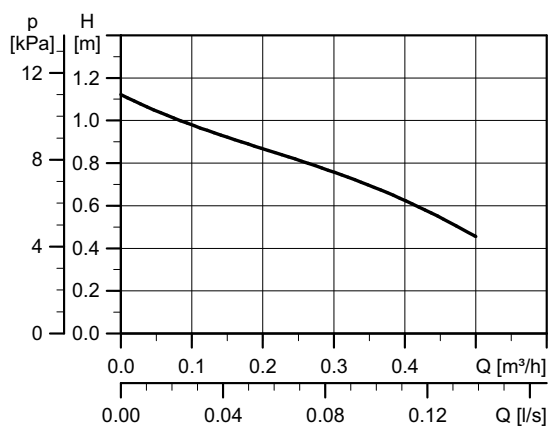

TM06 8415 0617

Electrical data, 1 x 230 V, 50/60 Hz

P1 [W]	I _{1/1} [A]
7	0.07

Dimensions

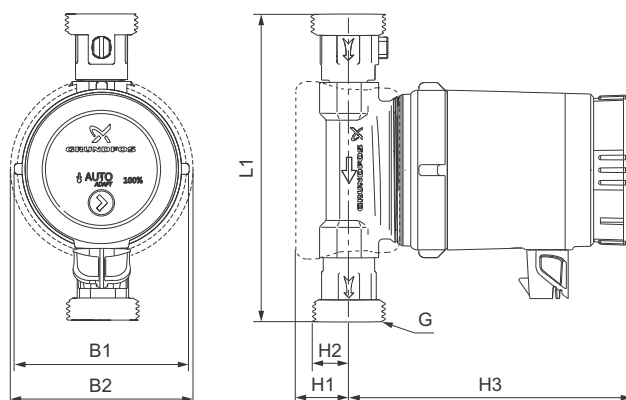

TM06 8298 5016

Connections: G 1
 System pressure: Max. 10 bar.
 Liquid temperature: 2-95 °C (TF 95).
 IP class: IP44

TM06 8285 5016

Pump type	Dimensions [mm]						Weights [kg]		Shipping volume [m³]	
	L1	H1	H2	H3	B1	B2	G	Net		Gross
COMFORT 15-14 BXA PM GB	140	25	21	129	79.5	84	G 1	1.35	1.51	0.0034

COMFORT 10-16 PM B5/LC

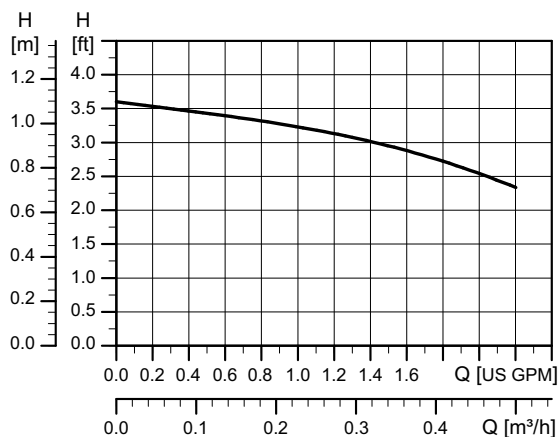

TM06 3624 0715

Electrical data, 1 x 115/230 V, 50/60 Hz

P1 [W]	I _{1/1} [A]
6	0.07

Dimensions

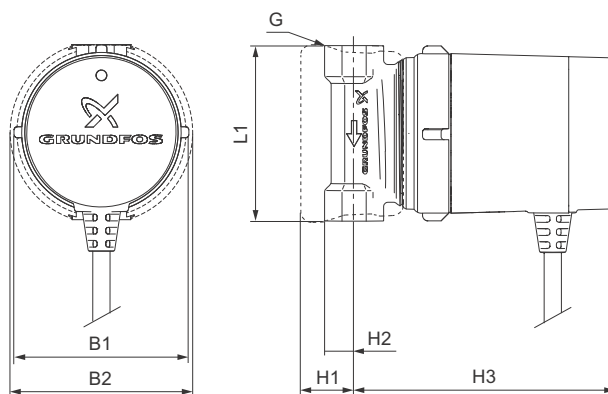

TM06 8292 5016

Connections: 1/2" NPT
 System pressure: 145 psi
 Liquid temperature: +2 °C to +80 °C / +35 °F to +176 °F
 IP class: IP44

TM06 8275 5016

Pump type	Dimensions [inches]							Weights [lb]		Shipping volume [ft ³]
	L1	H1	H2	H3	B1	B2	G	Net	Gross	
COMFORT 10-16 PM B5/LC	3 1/8	1	1/2	4 3/4	3	3 1/3	1/2" NPT	2.6	2.9	0.116

COMFORT 10-16 PM BN5/LC

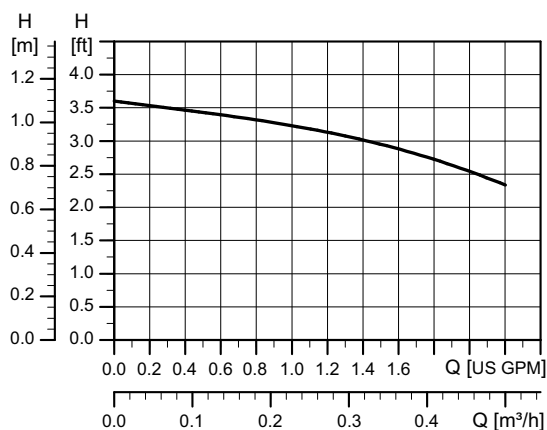

TM06 3624.0715

Electrical data, 1 x 115/230 V, 50/60 Hz

P1 [W]	I _{1/1} [A]
6	0.07

Dimensions

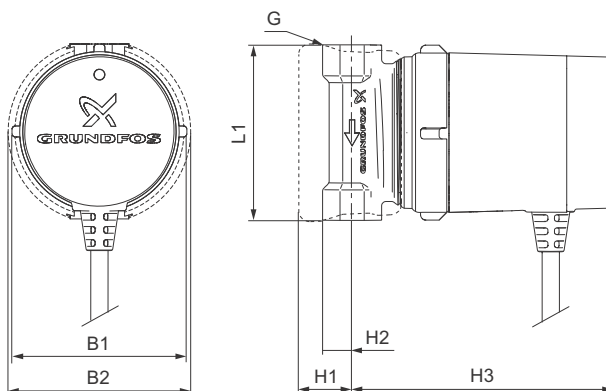

TM06 8275.5016

TM06 8292.5016

Pump type	Dimensions [inches]							Weights [lb]		Shipping volume [ft³]
	L1	H1	H2	H3	B1	B2	G	Net	Gross	
COMFORT 10-16 PM BN5/LC	3 1/8	1	1/2	4 3/4	3	3 1/3	1/2" NPT	2.6	2.9	0.116

COMFORT 10-16 T PM BN5/LC

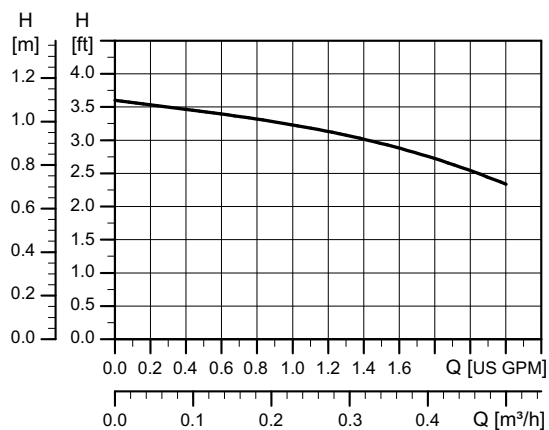

TM06 3624 0715



TM06 9246 2017

Electrical data, 1 x 115/230 V, 50/60 Hz

P1 [W]	I _{1/1} [A]
6	0.07

Connections: 1/2" NPT
 System pressure: Max. 145 psi
 Liquid temperature: +2 °C to +80 °C / +35 °F to +176 °F
 IP class: IP44

Dimensions

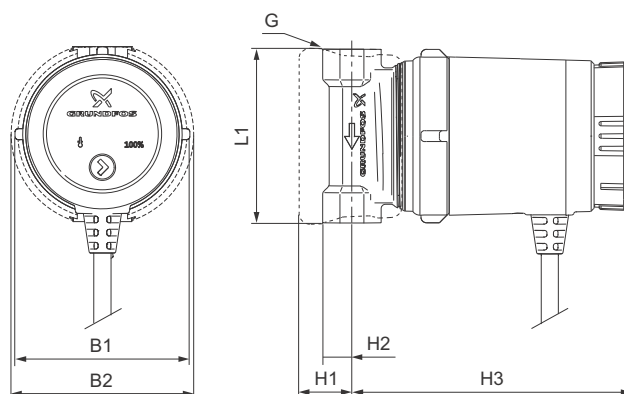

TM06 9251 2017

Pump type	Dimensions [inches]							Weights [lb]		Shipping volume [ft ³]
	L1	H1	H2	H3	B1	B2	G	Net	Gross	
COMFORT 10-16 T PM BN5/LC	3 1/8	1	1/2	5 1/4	3	3 1/3	1/2" NPT	2.6	2.9	0.116

COMFORT 10-16 PM BU/LC

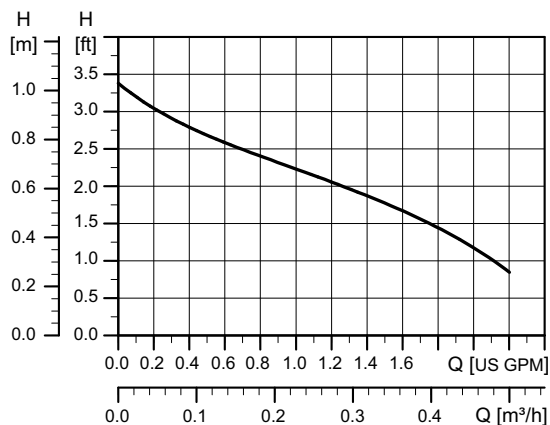

TM06 3625 0715

Electrical data, 1 x 115/230 V, 50/60 Hz

P1 [W]	I _{1/1} [A]
6	0.07

Connections: 1 1/4" NPSM
 System pressure: Max. 145 psi
 Liquid temperature: +2 °C to +80 °C / +35 °F to +176 °F
 IP class: IP44

TM06 5324 4315

Dimensions

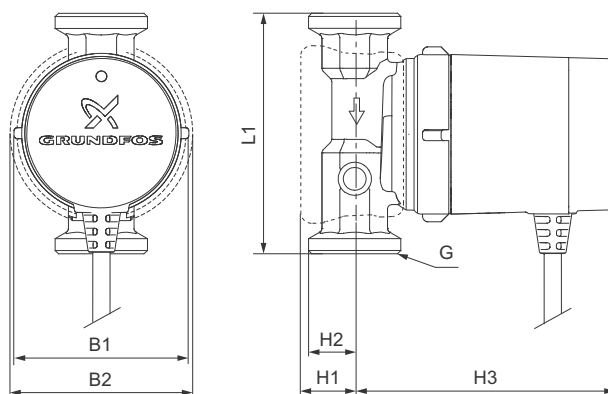

TM06 8299 5016

Pump type	Dimensions [inches]							Weights [lb]		Shipping volume [ft³]
	L1	H1	H2	H3	B1	B2	G	Net	Gross	
COMFORT 10-16 PM BU/LC	4 1/3	1	7/8	4 3/4	3	3 1/3	1 1/4" NPSM	3.4	3.8	0.152

COMFORT 10-16 A PM B5/LC

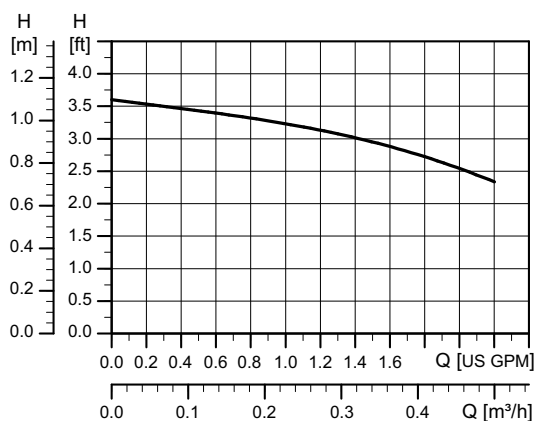

TM06 3624 0715

Electrical data, 1 x 115/230 V, 50/60 Hz

P1 [W]	I _{1/1} [A]
6	0.07

Dimensions

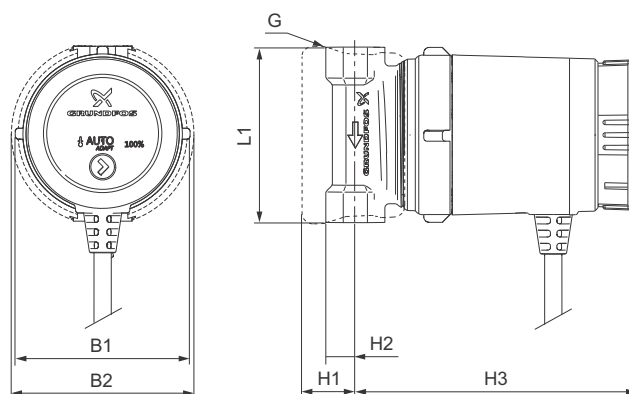

TM06 9448 2317

Connections: 1/2" NPT
 System pressure: Max. 145 psi
 Liquid temperature: +2 °C to +80 °C / +35 °F to +176 °F
 IP class: IP44

TM06 8274 5016

Pump type	Dimensions [inches]							Weights [lb]		Shipping volume [ft ³]
	L1	H1	H2	H3	B1	B2	G	Net	Gross	
COMFORT 10-16 A PM B5/LC	3 1/8	1	1/2	5 1/4	3	3 1/3	1/2" NPT	2.6	2.9	0.116

COMFORT 10-16 A PM BN5/LC

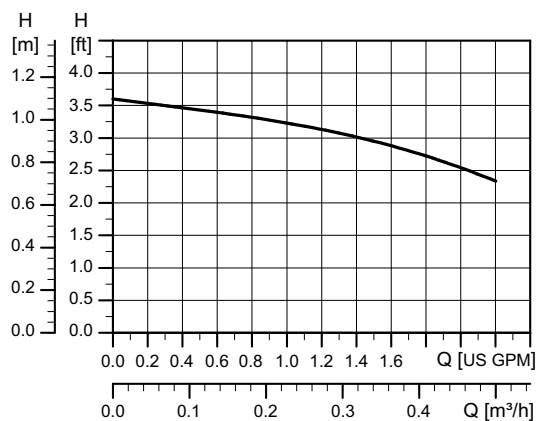

TM06 3624 0715



TM06 8274 5016

Electrical data, 1 x 115/230 V, 50/60 Hz

P1 [W]	I _{1/1} [A]
6	0.07

Connections: 1/2" NPT
 System pressure: Max. 145 psi
 Liquid temperature: +2 °C to +80 °C / +35 °F to +176 °F
 IP class: IP44

Dimensions

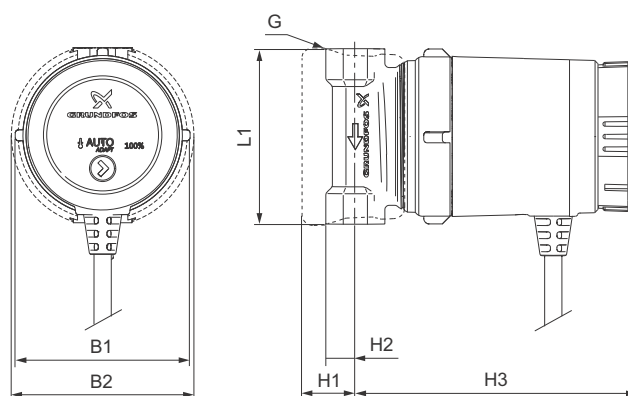

TM06 9448 2317

Pump type	Dimensions [inches]							Weights [lb]		Shipping volume [ft ³]
	L1	H1	H2	H3	B1	B2	G	Net	Gross	
COMFORT 10-16 A PM BN5/LC	3 1/8	1	1/2	5 1/4	3	3 1/3	1/2" NPT	2.6	2.9	0.116

COMFORT 10-16 A PM BU/LC

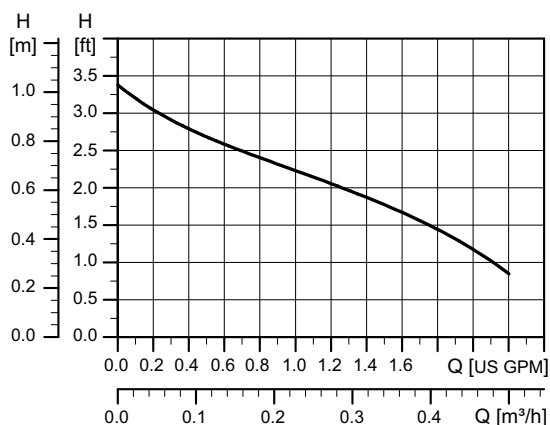

TM06 3625 0715

Electrical data, 1 x 115/230 V, 50/60 Hz

P1 [W]	I _{1/1} [A]
6	0.07

Connections: 1 1/4" NPSM
 System pressure: Max. 145 psi
 Liquid temperature: +2 °C to +80 °C / +35 °F to +176 °F
 IP class: IP44

TM06 5323 4315

Dimensions

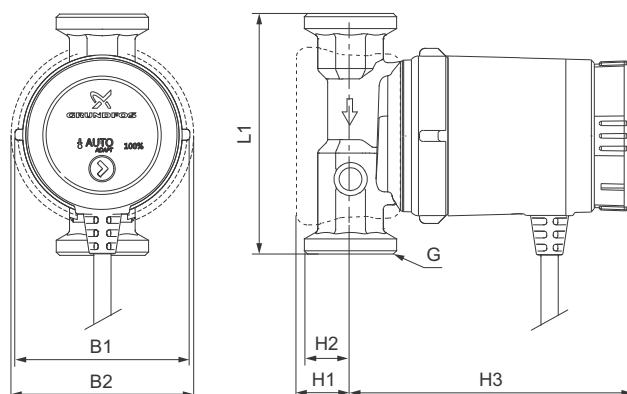

TM06 8300 1515

Pump type	Dimensions [inches]						Weights [lb]		Shipping volume [ft ³]	
	L1	H1	H2	H3	B1	B2	Net	Gross		
COMFORT 10-16 A PM BU/LC	4 1/3	1	7/8	5 1/4	3	3 1/3	1 1/4" NPSM	3.4	3.8	0.152

7. Product numbers

COMFORT, International, DACH, GB, CN, 50/60 Hz

Market region	Pump type	Product number	Port-to-port length [mm]	Connection	Supplied with		Data sheet
					Plug	Isolating valve Non-return valve	
International	COMFORT 15-14 B PM	97916771	80 mm	Rp 1/2			page 14
	COMFORT 15-14 BS PM	98492992					page 15
	COMFORT 15-14 BT PM	99279863					page 16
	COMFORT 15-14 BA PM	97916757					page 17
	COMFORT 15-14 BX PM	97916772	140 mm	G 1		•	page 18
	COMFORT 15-14 BXS PM	98492994				•	page 19
	COMFORT 15-14 BXT PM	99279864				•	page 20
	COMFORT 15-14 BXA PM	97916749				•	page 21
Germany Austria Switzerland	COMFORT 15-14 B PM DACH	97989265	80 mm	Rp 1/2			page 14
	COMFORT 15-14 BS PM DACH	99302353					page 15
	COMFORT 15-14 BT PM DACH	99279865					page 16
	COMFORT 15-14 BA PM DACH	99302331					page 17
	COMFORT 15-14 BX PM DACH	97989266	140 mm	G 1		•	page 18
	COMFORT 15-14 BXS PM DACH	99302354				•	page 19
	COMFORT 15-14 BXT PM DACH	99279866				•	page 20
	COMFORT 15-14 BXA PM DACH	99302332				•	page 21
COMFORT 15-14 MBS PM DACH	99302355	-	-			page 22	
Great Britain	COMFORT 15-14 B PM GB	99164484	80 mm	Rp 1/2	•		page 23
	COMFORT 15-14 BT PM GB	99279867			•		page 24
	COMFORT 15-14 BA PM GB	99164487			•		page 25
	COMFORT 15-14 BX PM GB	99164486	140 mm	G 1	•	•	page 26
	COMFORT 15-14 BXT PM GB	99279868			•	•	page 27
	COMFORT 15-14 BXA PM GB	99164488			•	•	page 28
	COMFORT 15-14 MBS PM GB	99302355					page 22
China	COMFORT 15-14 B PM CN	98485504	80 mm	Rp 1/2			page 14
	COMFORT 15-14 BT PM CN	99279869					page 16
	COMFORT 15-14 BA PM CN	98485557					page 17





COMFORT, USA, 50/60 Hz

Market region	Pump type	Product number	Port-to-port length [inches]	Connection	Supplied with		Data sheet
					Line cord	Isolating valve Non-return valve	
USA ★	COMFORT 10-16 PM B5/LC	98420206	3 1/8"	1/2" NPT	•		page 29
	COMFORT 10-16 PM BN5/LC	98420210			•		page 30
	COMFORT 10-16 T PM BN5/LC	99279870			•		page 31
	COMFORT 10-16 PM BU/LC	98420221	4 1/3"	1 1/4" NPSM	•	•	page 32
	COMFORT 10-16 A PM B5/LC	98420222	3 1/8"	1/2" NPT	•		page 33
	COMFORT 10-16 A PM BN5/LC	98420223			•		page 34
	COMFORT 10-16 A PM BU/LC	98420224			4 1/3"	1 1/4" NPSM	•

★ Lead-free pump housing

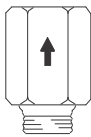
8. Accessories

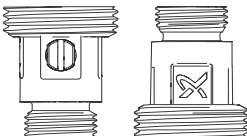
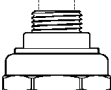
Fittings

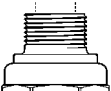
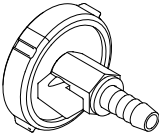
Fitting	Description	Connection	Material	Product number
 TM01 8647 0300	Non-return valve	1/2	Brass	96433904
 TM01 8648 0300	Isolating valve	1/2	Brass	96433905
 TM06 8451 0617	Fittings with integrated non-return valve and isolating valve	G 1 x Rp 1/2 int.	Brass	00ID8748
 TM01 8643 0300	Union set	G 1 1/4 x 15 mm int. R 1/2 ext.	Brass	96433907
 TM01 8644 0300	Union set	G 1 1/4 x Rp 3/4 int.	Brass	96433908
 TM01 8645 0300	Union set	G 1 1/4 x Rp 1/2 int. R 3/4 ext.	Brass	96433909
 TM01 8560 0300	Venting flange	Flange Union nut Hose	PP Brass PE	96433906
Bulk COMFORT PM plug (80 pcs.)				98890117

Spare parts

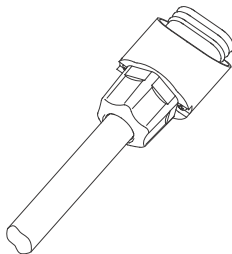

TM01 9911 3400

Description	Product number
Spare plug for COMFORT PM	98685259

9. Grundfos Product Center

Online search and sizing tool to help you make the right choice.

<http://product-selection.grundfos.com>



"SIZING" enables you to size a pump based on entered data and selection choices.

"REPLACEMENT" enables you to find a replacement product. Search results will include information on

- the lowest purchase price
- the lowest energy consumption
- the lowest total life cycle cost.

The screenshot shows the Grundfos Product Center website. At the top, there is a navigation bar with the logo and menu items: HOME, FIND PRODUCT, COMPARE, YOUR PROJECTS, SAVED ITEMS, HELP. Below this is a search bar with a 'SEARCH' button. The main content area features four large buttons: 'SIZING' (Enter pump sizing), 'CATALOGUE' (Products and services), 'REPLACEMENT' (Replace an old pump with a new), and 'LIQUIDS' (Find pump by liquid). Below these is a 'QUICK SIZING' section with input fields for 'Flow (Q)*' (m³/h) and 'Head (H)*' (m), and radio buttons for 'Select what to size by': 'Size by application', 'Size by pump design', and 'Size by pump family'. A 'START SIZING' button is also present. At the bottom, there are options for 'ADVANCED SIZING' with checkboxes for 'Advanced sizing by application' and 'Guided selection'.

www.grundfos.com Login

GRUNDFOS | PRODUCT CENTER Product range: United Kingdom | 50 Hz | Language: English
Change settings

HOME FIND PRODUCT COMPARE YOUR PROJECTS SAVED ITEMS HELP 1.4.23

FIND PRODUCTS AND SOLUTIONS

Input product number or a whole or partial product name

SIZING
Enter pump sizing

CATALOGUE
Products and services

REPLACEMENT
Replace an old pump with a new

LIQUIDS
Find pump by liquid

QUICK SIZING

Enter duty point:

Flow (Q)* m³/h

Head (H)* m

Select what to size by:

Size by application

Size by pump design

Size by pump family

START SIZING

ADVANCED SIZING: Advanced sizing by application Guided selection

"SIZING" enables you to size a pump based on entered data and selection choices.

"REPLACEMENT" enables you to find a replacement product. Search results will include information on

- the lowest purchase price
- the lowest energy consumption
- the lowest total life cycle cost.

"CATALOGUE" gives you access to the Grundfos product catalogue.

"LIQUIDS" enables you to find pumps designed for aggressive, flammable or other special liquids.

All the information you need in one place

Performance curves, technical specifications, pictures, dimensional drawings, motor curves, wiring diagrams, spare parts, service kits, 3D drawings, documents, system parts. The Product Center displays any recent and saved items - including complete projects - right on the main page.

Downloads

On the product pages, you can download installation and operating instructions, data booklets, service instructions, etc. in PDF format.

Subject to alterations.

98553150 0717

ECM: 1199343

GRUNDFOS A/S
DK-8850 Bjerringbro . Denmark
Telephone: +45 87 50 14 00
www.grundfos.com

GRUNDFOS 