

For the competent person

Installation manual



Air/flue gas systems

ecoTEC pro/ecoTEC plus/ecoTEC exclusive

GB, IE

Publisher/manufacture

Vaillant GmbH

Berghauser Str. 40 ■ D-42859 Remscheid
Tel. +49 21 91 18-0 ■ Fax +49 21 91 18-2810
info@vaillant.de ■ www.vaillant.de

 **Vaillant**

Contents

Contents

1	Safety	3
1.1	Action-related warnings	3
1.2	Intended use	3
1.3	General safety information	3
1.4	CE certification.....	5
1.5	Regulations (directives, laws, standards)	5
2	Notes on the documentation	6
2.1	Observing other applicable documents	6
2.2	Storing documents.....	6
2.3	Applicability of the instructions	6
3	Certified air/flue gas systems and components	7
3.1	System overview, 60/100 mm diameter	7
3.2	System overview, 80/125 mm diameter	8
4	System conditions	9
4.1	Route of the air/flue pipe in buildings	9
4.2	Location of the opening	9
4.3	Disposing of condensate	9
4.4	Maximum pipe lengths.....	9
5	Installation	11
5.1	Installing the connection piece for the 80/125 mm diameter air/flue pipe	11
5.2	Installing horizontal wall/roof ducts	11
5.3	Installing terminal kits for 60/100 mm diameter air/flue gas systems	14
5.4	Installing the vertical roof duct	19
5.5	Installing the concentric connection, 60/100 mm diameter, to the air/flue gas system for negative pressure	23
5.6	Installing the sliding sleeve, elbows and extensions.....	24
6	Customer service	35
Index		36



1 Safety

1.1 Action-related warnings

Classification of action-related warnings

The action-related warnings are classified in accordance with the severity of the possible danger using the following warning signs and signal words:

Warning symbols and signal words



Danger!

Imminent danger to life or risk of severe personal injury



Danger!

Risk of death from electric shock



Warning.

Risk of minor personal injury



Caution.

Risk of material or environmental damage

1.2 Intended use

The air/flue pipes described here are constructed using state-of-the-art technology in accordance with the recognised safety rules and regulations. Nevertheless, there is still a risk of injury or death to the system operator or others or of damage to the products and other property in the event of improper use or use for which the products are not intended.

The air/flue pipes mentioned in these instructions must only be used in conjunction with the product types mentioned in these instructions.

Any other use that is not specified in these instructions, or use beyond that specified in this document, shall be considered improper use.

Intended use includes the following:

- observance of accompanying operating, installation and servicing instructions for all system components
- installing and fitting the product in accordance with the product and system approval
- compliance with all inspection and maintenance conditions listed in the instructions.

1.3 General safety information

1.3.1 Risk caused by inadequate qualifications

The following work must only be carried out by competent persons who are sufficiently qualified to do so:

- Installation
- Disassembly
- Installation
- Start-up
- Maintenance
- Repair
- Decommissioning
- ▶ Observe all instructions that are included with the product.
- ▶ Proceed in accordance with the current state of technology.
- ▶ Observe all applicable directives, standards, laws and other regulations.

1.3.2 Risk of poisoning due to escaping flue gas

Improperly installed flue gas pipes may cause flue gas to escape.

- ▶ Before starting up the product, check that the whole air/flue pipe is securely fastened and leak-tight.

The flue gas pipe may become damaged by unforeseeable external influences.

- ▶ As part of the annual maintenance, inspect the flue gas installation in terms of:
 - external faults such as brittleness and damage
 - safe pipe connections and secure fastenings

1.3.3 Risk of death from escaping flue gas

- ▶ Ensure that all inspection and measurement openings in the air/flue pipe that are within the building and can be opened are always closed for start-up and during operation.

Flue gas may escape from leaking pipes or damaged seals. Mineral-oil-based greases can damage the seals.



1 Safety



- ▶ When installing the flue gas installation, use only flue gas pipes that are made from the same material.
- ▶ Do not install any damaged pipes.
- ▶ File off sharp burrs and chamfer the ends of the pipes before installing them, and dispose of the shavings.
- ▶ Never use mineral-oil-based grease for the installation.
- ▶ To facilitate the installation, use only water, standard commercial soft soap or, if required, the supplied lubricant.

Mortar residues, shavings, etc., in the flue gas route may restrict the outward flow of the flue gas, meaning that flue gas can escape.

- ▶ After installation, remove all mortar residues, shavings, etc., from the air/flue pipe.

1.3.4 Risk of death from leaks in the flue gas route

Extensions that are not fixed to the wall or ceiling may become disengaged due to sagging or thermal expansion.

- ▶ Ensure that every extension is fixed to the wall or ceiling by means of a pipe clamp. The distance between two pipe clamps must not be greater than the length of the extension, and must not exceed 2 m.

Condensate that collects inside the flue in certain areas can damage the flue gas pipe seals.

- ▶ Install the horizontal flue pipe to the product with a downward gradient.
 - Downward gradient to the product: 3°



Note

3° corresponds to a downward gradient of approx. 50 mm per metre of pipe length.

1.3.5 Risk of fire and damage to electronics caused by lightning

- ▶ If the building is equipped with a lightning protection system, incorporate the air/flue pipe into the lightning protection.
- ▶ If the flue gas pipe (parts of the air/flue pipe situated outside the building) contains

metal materials, incorporate it into the potential equalisation system.

1.3.6 Risk of injury from ice formation

Where air/flue pipes penetrate the roof, the water vapour contained in flue gas may precipitate as ice on the roof or the roof structures.

- ▶ Ensure that this ice formation does not slide from the roof.

1.3.7 Risk of damage to the structure of the building due to moisture

As a result of improper installation, water may penetrate the building and cause material damage.

- ▶ Observe the definitions in the directives for the planning and implementation of roofs with seals.

1.3.8 Product damage caused by adjacent channel vents

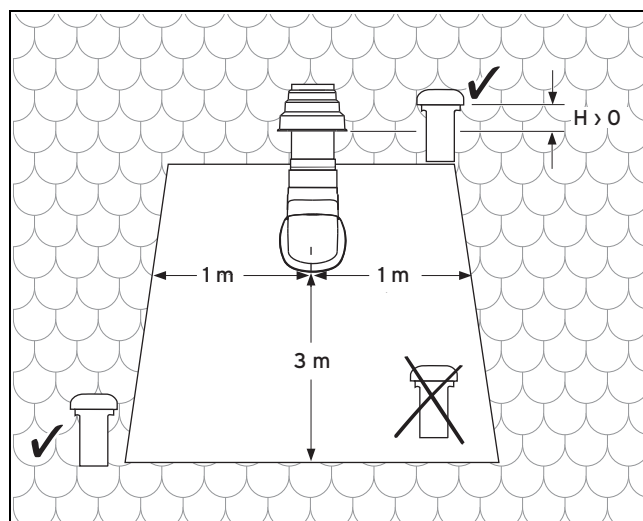

Extremely damp exhaust air escapes from the channel vents. This may condense in the air pipe and cause damage to the product.

- ▶ Observe the requirements for minimum clearances in accordance with the illustration.

1.3.9 Requirements for the air/flue pipe opening

As a result of improper installation, water may penetrate the building and cause material damage.





- ▶ Observe the requirements for the air/flue pipe opening in the boiler's installation instructions.

1.3.10 Risk of material damage caused by using an unsuitable tool

- ▶ Use the correct tool to tighten or loosen screw connections.

1.4 CE certification

The heat generators are certified as gas consumption appliances with attached flue gas installation in accordance with the EU gas appliances directive 2009/142/EC. This Installation Manual is a component of the certification and is cited in the type testing certificate. In compliance with the regulatory statutes of this installation manual, the proof of usability of the elements identified by Vaillant article numbers that are designed for the flue pipe is provided. If you do not use certified elements for the Vaillant air/flue gas pipe when installing the heat generators, this voids the CE conformity of the heat generator. We therefore strongly recommend that you fit Vaillant air/flue gas systems.

1.5 Regulations (directives, laws, standards)

- ▶ Observe the national regulations, standards, guidelines and laws.



2 Notes on the documentation

2 Notes on the documentation

2.1 Observing other applicable documents

- ▶ You must always observe the installation instructions for the installed heat generator.

2.2 Storing documents

- ▶ Pass these instructions and all other applicable documents on to the system operator.

2.3 Applicability of the instructions

These instructions apply only for the heat generators named in the other applicable documents, hereinafter referred to as the "product".

3 Certified air/flue gas systems and components

3.1 System overview, 60/100 mm diameter

Art. no.	Air/flue gas systems, concentric
0020223472	Vertical roof duct (black, RAL 9005), with collar
303982	Vertical ridge roof duct
0020219517	Horizontal wall duct, 0.7 m
0020219518	Horizontal telescopic wall duct (only available in black)
0020219519	Horizontal wall duct, 1.7 m

3.1.1 Components

The following table lists the air/flue gas systems that are permitted as part of the system certification, along with their certified components.

Optional connection accessories	Art. no.	0020223472	303982	0020219517 0020219519	0020219518
Extension (PP), concentric, 470 mm, 60/100 mm diameter	303902	X	X	X	X
Extension (PP), concentric, 970 mm, 60/100 mm diameter	303903	X	X	X	X
Extension (PP), concentric, 1970 mm, 60/100 mm diameter	303905	X	X	X	X
Extension (PP), concentric, 3960 mm, 60/100 mm diameter ¹⁾	0020138174	X	X	X	X
45° elbow (2 x), concentric	303911	X	X	X	X
87° elbow, concentric	303910	X	X	X	X
Pipe clamps (5 x), 100 mm diameter	303821	X	X	X	X
Adjustable pipe clamps (3 x), 100 mm diameter	303935	X	X	X	X
Sliding sleeve	303915	X	X	X	X
Pitched roof tile	009076 (black)	X			
Universal pitched roof tile	303980	X			
Flat roof penetration collar	009056	X			
Telescopic extension, 440-690 mm, 60/100 mm diameter	303906	X	X		
Telescopic offset piece	303919	X	X		
Black terminal kit for horizontal air/flue pipe	0020219537			X	X
Variable terminal kit (VTK), black ²⁾	0020219529			X	X
Variable terminal kit (VTK), white ²⁾	0020219530			X	X
Extension for variable terminal kit (VTK), 60 mm diameter, 1 m, black ²⁾	0020219539			X	X
Extension for variable terminal kit (VTK), 60 mm diameter, 1 m, white ²⁾	0020219540			X	X
87° elbow for variable terminal kit (VTK), black ²⁾	0020219543			X	X
87° elbow for variable terminal kit (VTK), white ²⁾	0020219544			X	X
45° elbow (2 x) for variable terminal kit (VTK), black	0020219551			X	X
45° elbow (2 x) for variable terminal kit (VTK), white	0020219552			X	X

1) To reduce the pipe connections that need to be inspected, 4 m extensions are offered on request. (Special delivery with minimum purchasing quantity. No returns accepted.) The required downward gradient is also 3°. A height of 200 mm is therefore required for the 4 m extension. Take the height into consideration when selecting the installation site.

2) Delivery with pipe clamps

3 Certified air/flue gas systems and components

Optional connection accessories	Art. no.	0020223472	303982	0020219517 0020219519	0020219518
Deflector set, DN 60, PP, black	0020219533			X	X
Deflector set, DN 60, PP, white	0020219534			X	X
1) To reduce the pipe connections that need to be inspected, 4 m extensions are offered on request. (Special delivery with minimum purchasing quantity. No returns accepted.) The required downward gradient is also 3°. A height of 200 mm is therefore required for the 4 m extension. Take the height into consideration when selecting the installation site. 2) Delivery with pipe clamps					

3.2 System overview, 80/125 mm diameter

Art. no.	Air/flue gas systems, concentric
303209	Horizontal roof duct
303200	Vertical roof duct

3.2.1 Components

The following table lists the air/flue gas systems that are permitted as part of the system certification, along with their certified components.

Optional connection accessories	Art. no.	303200	303209
Connection piece (screw holes, 4 x)	303926	X	X
Connection piece with bayonet connection	0020147469	X	X
Extension (PP), concentric, 470 mm, 80/125 mm diameter	303202	X	X
Extension (PP), concentric, 970 mm, 80/125 mm diameter	303203	X	X
Extension (PP), concentric, 1970 mm, 80/125 mm diameter	303205	X	X
45° elbow (2 x), concentric, 80/125 mm diameter	303211	X	X
87° elbow, concentric, 80/125 mm diameter	303210	X	X
Pipe clamps (5 x), 125 mm diameter	303616	X	X
Sliding sleeve, 80/125 mm diameter	303215	X	X
Pitched roof tile	009076 (black)	X	
Universal pitched roof tile	303980	X	
Flat roof penetration collar	009056	X	

4 System conditions

4.1 Route of the air/flue pipe in buildings

The route of the air/flue pipe should correspond to the shortest and the most direct distance between the product and the flue gas installation opening, and it should run as straight as possible.

- ▶ Do not arrange several elbows or inspection elements immediately after each other.

As a result of standards relating to the hygiene of drinking water, water pipes must be protected against impermissible heating.

- ▶ Lay the air/flue pipe separately from the drinking water pipes.

It must be possible to check and, if required, clean the entire length of the flue gas route.

It must be possible to remove the air/flue pipe again with minimal effort (no time-consuming structural or cementing work in the living area, but screwed-in casing instead). If they are arranged in shafts, they are usually easy to remove.

4.2 Location of the opening

The location of the flue gas installation opening must comply with the relevant applicable international, national and/or local regulations.

- ▶ Align the opening of the flue gas installation in such a way that ensures a secure outward flow and distribution of the flue gases and prevents these gases from re-entering the building through openings (windows, air intake openings and balconies).

4.3 Disposing of condensate

Local regulations may stipulate the minimum quality of any condensate that may enter the public waste-water system. If required, a condensate neutraliser must be used.

- ▶ When disposing of the condensate into the public waste-water system, observe the local regulations.
- ▶ Only use corrosion-resistant piping material for removing condensate.

4.4 Maximum pipe lengths

4.4.1 Maximum pipe length for horizontal wall duct

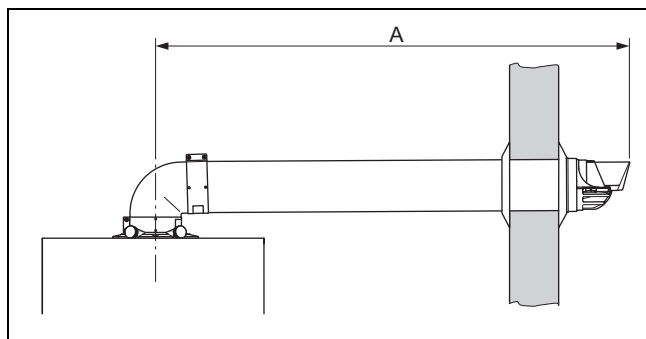

A Maximum pipe length

4.4.2 Maximum pipe length of the horizontal wall duct with vertical terminal kit (60/100 mm diameter only)

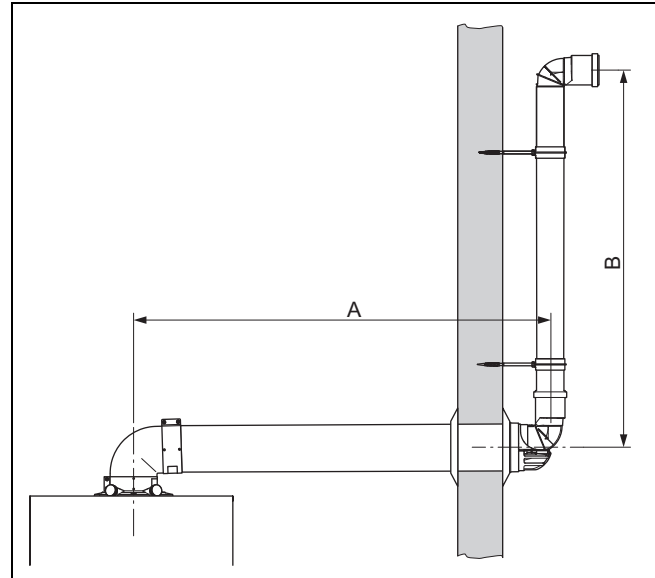

A Concentric pipe length B Outdoor pipe length

4.4.3 Maximum pipe length for vertical roof duct

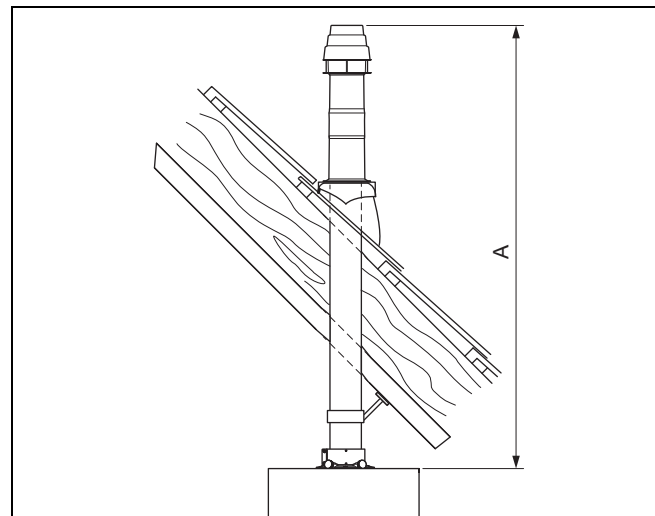

A Maximum pipe length

4 System conditions

4.4.4 Maximum pipe lengths, 60/100 mm diameter

Air/flue gas system	Art. no.	ecoTEC plus/ecoTEC pro/ecoTEC exclusive				
		VU GB 126/5-5 (612) A VU GB 156/5-5 (615) A	VU GB 186/5-5 (618) A VUW GB 256/5-5 (825) VUW GB 246/5-3 (24) A VUW GB 286/5-3 (28) A VUW GB 306/5-3 (30)	VUW GB 266/5-3 (26) A VU GB 226/5-3 (22) A VU 206/5-7 (H-GB)	VU GB 246/5-5 (624) A VU GB 306/5-5 (630) A VU GB 376/5-5 (637) A VUW GB 326/5-5 (832) VUW GB 386/5-5 (838) VUI GB 386/5-5 (937) A VUW GB 356/5-5 (835) VU 256/5-7 (H-GB)	835 (VUW 356/5-7 (H-GB)) 843 (VUW 436/5-7 (H-GB))
Max. concentric pipe length						
Horizontal wall/roof duct	0020219517 0020219518	22 m	12 m	8 m	5.5 m	5.5 m
		plus 1 x 87° elbow	plus 1 x 87° elbow	plus 1 x 87° elbow	plus 1 x 87° elbow	plus 1 x 87° elbow
The inclusion of additional elbows in the flue gas installation reduces the pipe length as follows:						
<ul style="list-style-type: none"> - By 0.5 m for each 45° elbow - By 1.0 m for each 87° elbow 						
Variable terminal kit	0020219529 0020219530 (with 0020219517 and 0020219518 only)	The maximum concentric pipe length that is specified above is reduced as follows:				not possible
<ul style="list-style-type: none"> - By 0.5 m with the variable terminal - By 0.5 m with each metre of VTK pipe - By 0.5 m with each 87° elbow - By 0.5 m for every two 45° elbows 						
Vertical roof duct	0020065937 303982	26 m	16 m	12 m	8 m	8 m
		The inclusion of additional elbows in the flue gas installation reduces the pipe length as follows:				
<ul style="list-style-type: none"> - By 0.5 m for each 45° elbow - By 1.0 m for each 87° elbow 						

4.4.5 Maximum pipe lengths, 80/125 mm diameter

Air/flue gas system	Art. no.	ecoTEC plus/ecoTEC pro/ecoTEC exclusive			
		VU GB 126/5-5 (612) A VU GB 156/5-5 (615) A	VU GB 186/5-5 (618) A VUW GB 256/5-5 (825) VUW GB 246/5-3 (24) A VUW GB 286/5-3 (28) A VUW GB 306/5-3 (30)	VUW GB 266/5-3 (26) A VU GB 226/5-3 (22) A VU 206/5-7 (H-GB)	VU GB 246/5-5 (624) A VU GB 306/5-5 (630) A VU GB 376/5-5 (637) A VUW GB 326/5-5 (832) VUW GB 386/5-5 (838) VUI GB 386/5-5 (937) A VUW GB 356/5-5 (835) VU 256/5-7 (H-GB) VUW 356/5-7 (H-GB) VUW 436/5-7 (H-GB)
Max. concentric pipe length ¹⁾					
Horizontal wall/roof duct	303209	25 m Plus 1 x 87° elbow	39 m Plus 1 x 87° elbow	29 m Plus 1 x 87° elbow	32 m Plus 1 x 87° elbow
Vertical roof duct	303200	27 m	41 m	31 m	34 m
1) The inclusion of additional elbows in the flue gas installation reduces the pipe length as follows:					
<ul style="list-style-type: none"> - By 1.0 m for each 45° elbow - By 2.5 m for each 87° elbow 					

5 Installation

5.1 Installing the connection piece for the 80/125 mm diameter air/flue pipe

- ▶ Convert the products that you want to connect to the air/flue pipe (80/125 mm diameter) and that are equipped with the product connection (60/100 mm diameter) at the factory.
 - The installation instructions for the product describe how to install the 80/125 mm diameter connection piece for the air/flue pipe.

5.2 Installing horizontal wall/roof ducts

5.2.1 Preparing the installation



Danger!

Risk of poisoning due to escaping flue gas.

If you select an unsuitable installation site for the air/flue pipe, flue gas may be allowed to enter the building.

- ▶ Observe the existing regulations with regard to the clearances to windows and ventilation openings.



Danger!

Risk of poisoning due to escaping flue gas.

Condensate that collects in a particular place can damage the flue gas pipe seals.

- ▶ Lay the horizontal flue pipe with a downward gradient of 3° to the product; 3° corresponds to a downward gradient of approx. 50 mm per metre of pipe length.
- ▶ In doing so, note that the air/flue pipe must be centred in the wall hole.

- ▶ Determine the installation site for the air/flue pipe.
- ▶ When installing the product near a light source, point out to the operator that they must clean the opening regularly. Otherwise, due to the insects that the light may attract, the opening may become dirty.

Installation example Horizontal roof duct

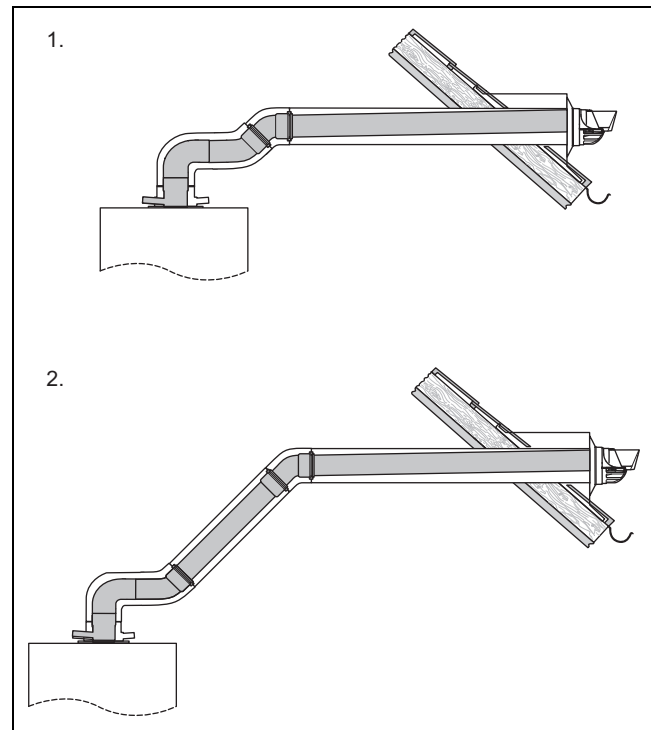

1 Direct installation 2 Offset installation

- Minimum dimensions for the dormer: Height x width: 300 mm x 300 mm
- ▶ Determine the installation site for the boiler (→ Installation instructions for the boiler).
- ▶ Ensure that all clearances required for installation and maintenance are available and that the air/flue gas system can be installed in accordance with these instructions.
- ▶ Secure the installation template that is supplied with the boiler to the wall.
- ▶ Use a plumb-bob or spirit level to check whether the central line of the installation template is vertical.

Conditions: Top connection, air/flue pipe to the rear

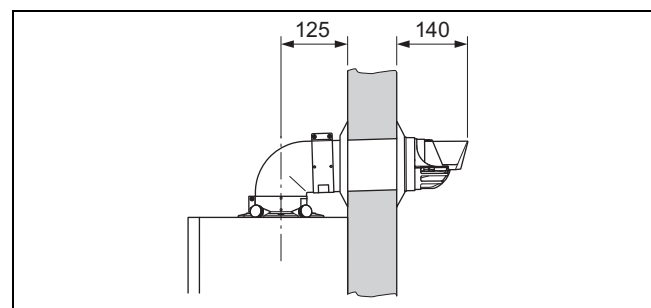

If you install the air/flue pipe directly on the rear of the boiler, the installation template shows the position of the wall duct for horizontal installation with the connection at the top

5 Installation

Conditions: Top connection, air/flue pipe to the side

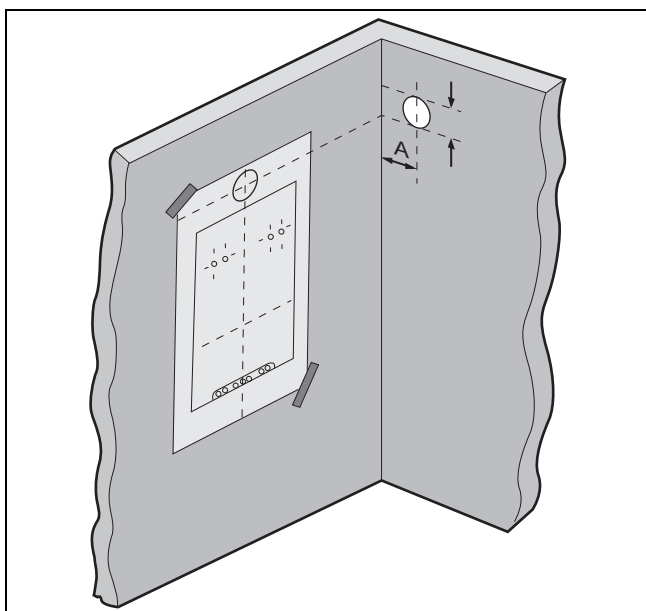

A = 125 mm

If you want to install the air/flue pipe laterally, you can determine the position of the wall duct by carefully offsetting the central line of the wall duct that is marked on the installation template.

- Calculate the required gradient in accordance with the length of the flue gas pipe and then mark the position for the wall duct.

5.2.2 Determining the clearance to the external wall

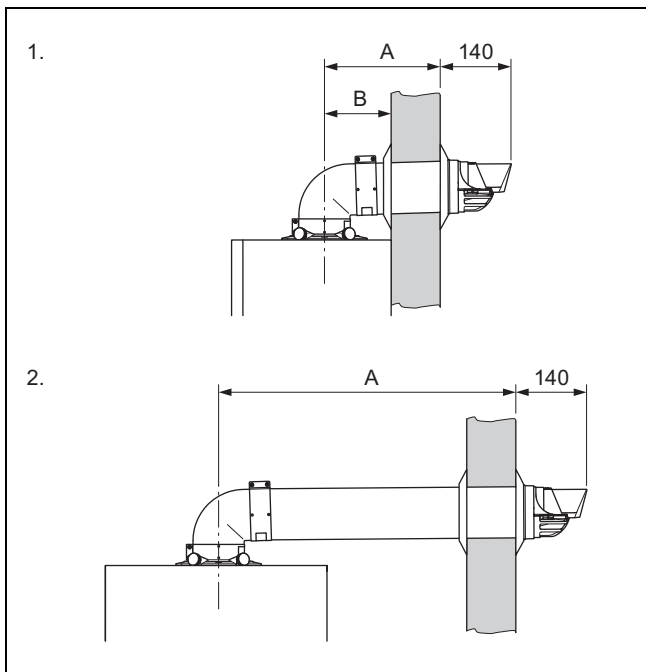

- | | | |
|------------------------------|---|--|
| 1. Flue gas pipe to the rear | A | Clearance to the external wall |
| 2. Flue gas pipe to the side | B | Clearance to the internal wall: 125 mm |

- Measure the clearance (**A**) from outside of the wall to the centre of the connection piece.

5.2.3 Installing the 60/100 mm diameter horizontal wall/roof duct, article number 0020219517

5.2.3.1 Scope of delivery

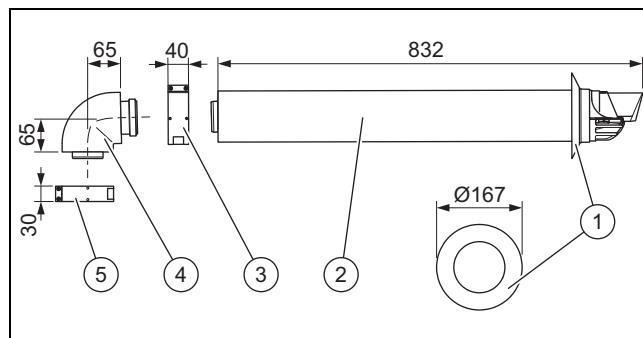

- | | | | |
|---|-----------------------------------|---|-------------|
| 1 | Wall collar, 100 diameter (2 pcs) | 3 | 40 mm clamp |
| 2 | Horizontal wall duct | 4 | 87° elbow |
| | | 5 | 30 mm clamp |

5.2.3.2 Shortening the air/flue gas pipe

- Determine the clearance to the external wall. (→ Page 12)

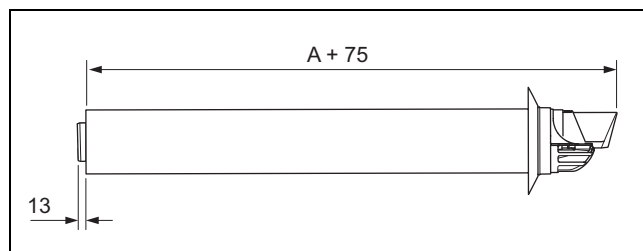

- Shorten the flue gas pipe and the air pipe by the same length when they are assembled.



Note

Disassembling the flue gas pipe and the air pipe damages the latching lugs in the terminal.

Conditions: Additional extensions and elbows required

- Install the extensions. (→ Page 25)
 - All of the sleeves for the flue gas pipe must point towards the terminal.
- Install the 45° elbow. (→ Page 28)
- Install the 87° elbow. (→ Page 29)

5.2.3.3 Installing the wall duct

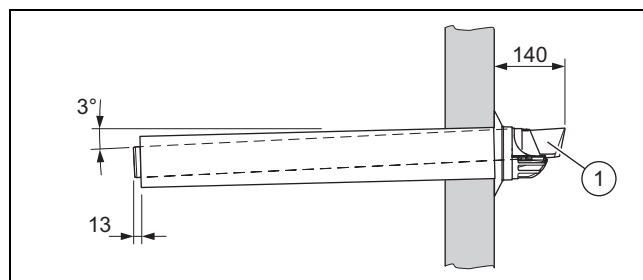

- Drill a hole.

– Diameter: 125 mm



Note

If the wall duct can be accessed from the exterior of the building, you can drill the hole with a diameter of 110 mm and install the wall duct with the wall collar from outside.

2. Slide the air/flue pipe (1) with the flexible external collar through the wall.
3. Pull the flue pipe back until the external collar forms a tight seal on the external wall.
4. Secure the flue pipe with mortar and leave the mortar to harden.
5. Install the wall collar on the inside of the wall.
6. Connect the wall/roof duct to the product using extensions, elbows and, if required, a sliding sleeve. (→ Page 14)

5.2.3.4 Installing the roof duct

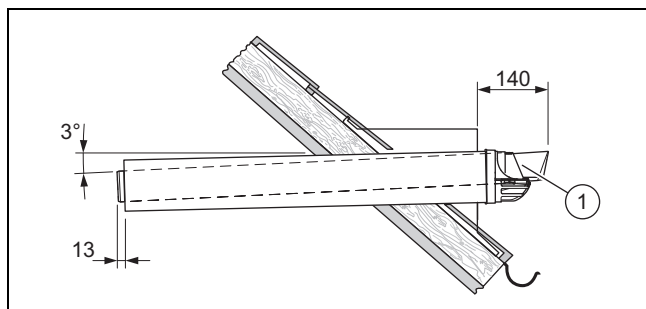

- ▶ Insert the air/flue pipe (1) with no external collar into the dormer.

5.2.4 Installing the horizontal telescopic wall/roof duct, 60/100 mm diameter, article number 0020219518

5.2.4.1 Scope of delivery

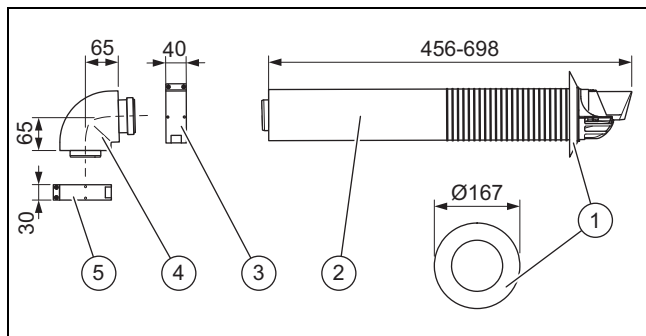

- | | | | |
|---|-----------------------------------|---|-------------|
| 1 | Wall collar, 100 diameter (2 pcs) | 3 | 40 mm clamp |
| 2 | Horizontal telescopic wall duct | 4 | 87° elbow |
| | | 5 | 30 mm clamp |

5.2.4.2 Installing the wall duct

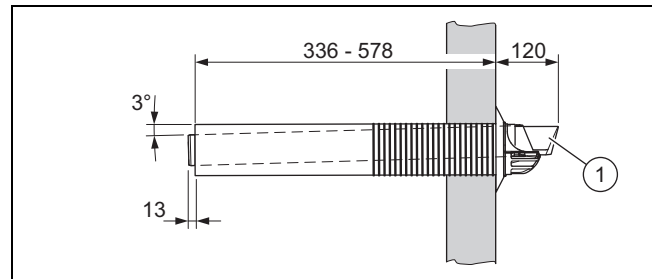

1. Drill a hole.
 - Diameter: 125 mm



Note

If the wall duct can be accessed from the exterior of the building, you can drill the hole with a diameter of 110 mm and install the wall duct with the wall collar from outside.

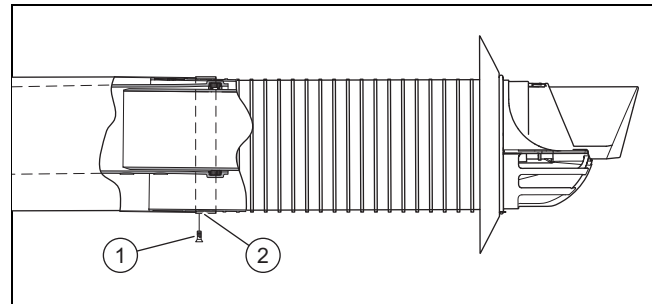

2. Determine the clearance to the external wall. (→ Page 12)
3. Set the telescopic wall duct to the correct length.
 - Note that the **TOP** symbol must point upwards on both ends.



Danger!

Risk of poisoning due to escaping flue gas.

Flue gas can escape if a flue gas pipe is damaged.

- ▶ Only use the self-tapping screw provided.

4. Secure the air pipes to each other by screwing the overlapping air pipes together using the supplied self-tapping screws on the underside (1).
5. Seal the gap in the telescopic air pipe using the supplied adhesive tape (2).
6. Slide the air/flue pipe (1) with the flexible external collar through the wall.
7. Pull the flue pipe back until the external collar forms a tight seal on the external wall.
8. Secure the flue pipe with mortar and leave the mortar to harden.
9. Install the wall collar on the inside of the wall.
10. Connect the wall/roof duct to the product using extensions, elbows and, if required, a sliding sleeve. (→ Page 14)

5 Installation

5.2.4.3 Installing the roof duct

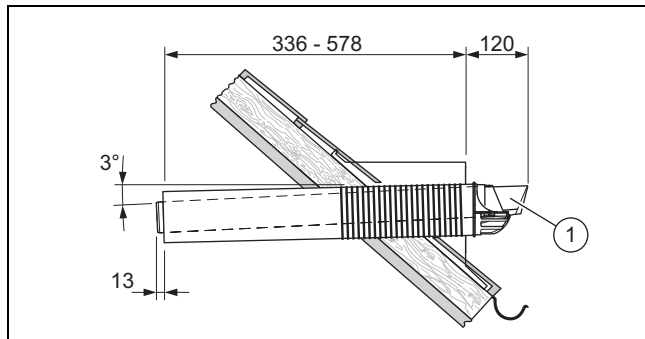

- ▶ Insert the air/flue pipe (1) without the external collar into the dormer.

5.2.5 Connecting the product

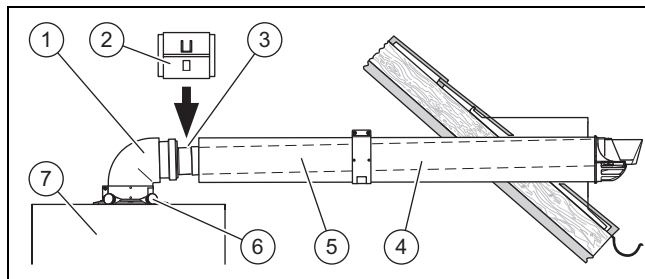

1. Install the product (7) – see the installation instructions for the product.
2. Connect the 87° elbow (1) to the connection piece for the air/flue pipe (6).
3. Fit the sliding sleeve (3) with the sleeve as far as it will go onto the wall/roof duct (4) or the extension (5).
4. If required, install the extensions.
5. Connect the sliding sleeve to the 87° elbow.
6. Install the air clamp (2) for the sliding sleeve.

7. Alternatives 1 / 2

Conditions: Wall/roof duct without extension

- ▶ Install the sliding sleeve. (→ Page 24)

7. Alternatives 2 / 2

Conditions: Wall/roof duct with extension

- ▶ Install the extensions. (→ Page 25)
- ▶ Install the 45° elbow. (→ Page 28)
- ▶ Install the 87° elbow. (→ Page 29)
- ▶ Install the sliding sleeve. (→ Page 24)
- ▶ Connect all of the disconnection points with air clamps. (→ Page 34)

5.3 Installing terminal kits for 60/100 mm diameter air/flue gas systems

5.3.1 Minimum clearances for the flue gas terminal

You must comply with the minimum clearances for the flue gas terminal that are defined in BS 5440, unless the boiler's manufacturer has given approval to use shorter minimum clearances that are not considered to be safety-critical.

Vaillant has reduced the minimum clearances for the flue gas terminal and specifies this in the installation instructions for the boiler. These are minimum clearances that are to be

used for all types of installation, except for the installation of the variable terminal kit (VTK).

If a VTK is connected to a horizontal flue gas pipe, terminal clearances are reduced for the air inlet. The terminal clearances on the "new" flue outlet at the end of VTK remain unchanged.

On the VTK, the minimum clearances for the air inlet A, B and C (→ Installation instructions for the boiler) to openings (e.g. a window) are reduced to 150 mm. This means that the terminal will be at the horizontal flue gas pipe when a VTK is connected to the air inlet and can therefore be installed at a clearance of less than 300 mm from a window opening or a ventilation tile.

5.3.2 Black terminal kit – article number 0020219537

5.3.2.1 Scope of delivery

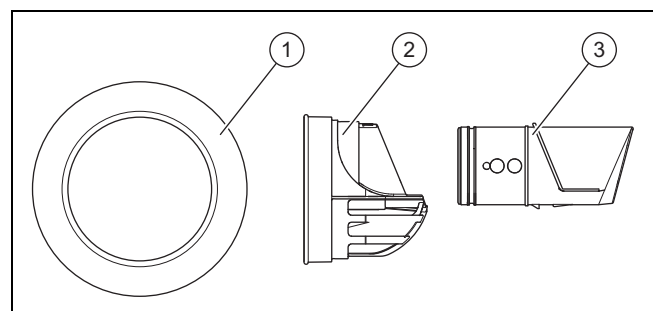

- | | | | |
|---|---------------|---|----------|
| 1 | Wall collar | 3 | End pipe |
| 2 | Opening piece | | |

5.3.2.2 Installing the black terminal (change of colour)



Note

You must install the terminal kits before installing the flue gas pipe.

Conditions: Terminal secured using screws

- ▶ Undo the lateral screws.

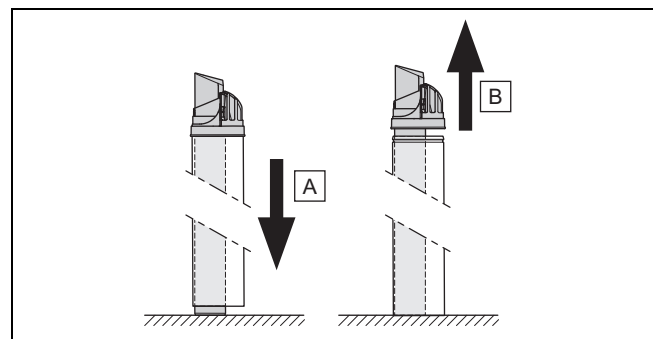

1. Detach the terminal with the flue gas pipe by pushing the air pipe to the floor.



Note

You cannot reuse the terminal as detaching the terminal damages the latching lugs in the terminal.

2. Pull the terminal from the air pipe together with the flue gas pipe.

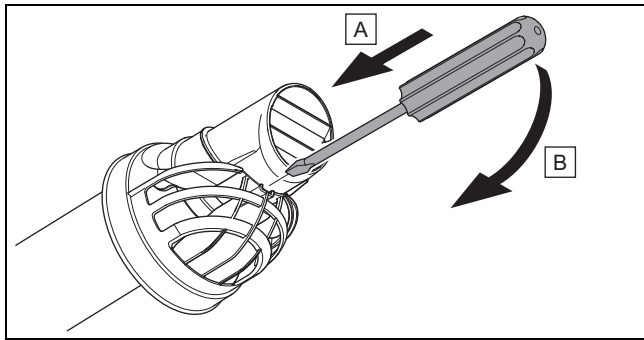

3. Release the catch between the opening piece and the end pipe.

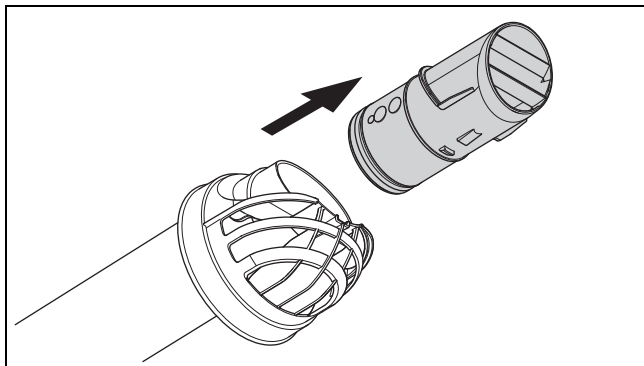

4. Pull the end pipe from the opening piece.

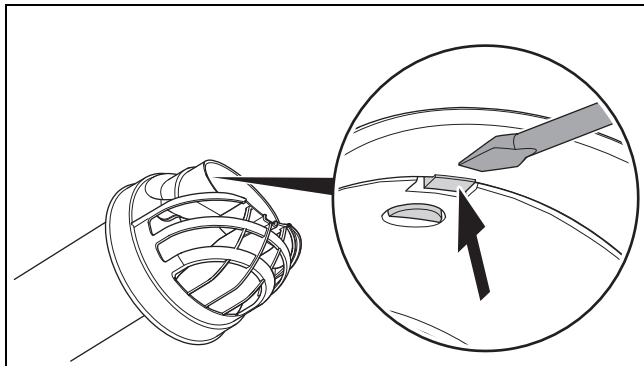

5. Release the catch between the opening piece and the flue gas pipe.

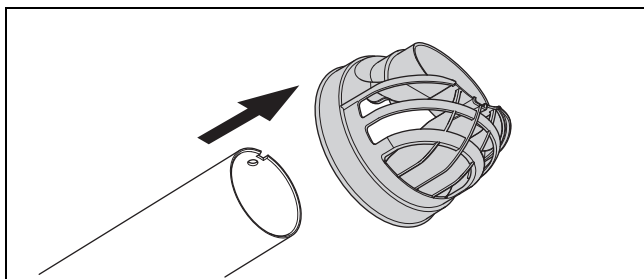

6. Pull the opening piece from the flue gas pipe.

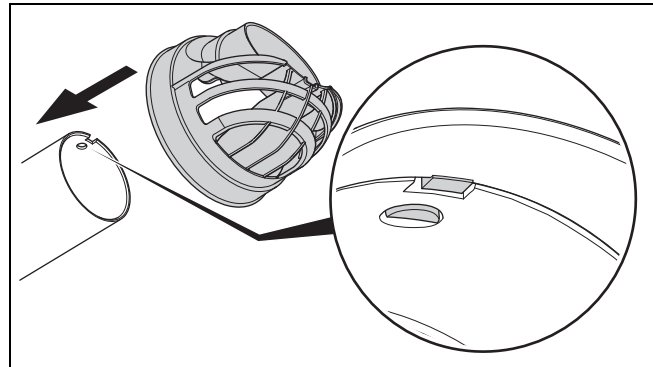

7. Slide the new opening piece onto the flue pipe until you hear the opening piece click into place.

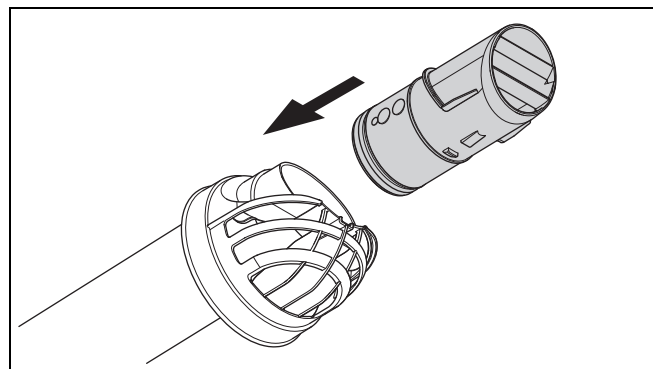

8. Slide the end pipe onto the opening piece until you hear the end pipe click into place.

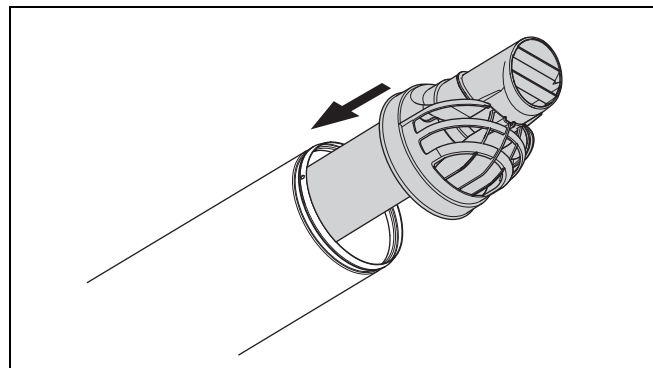

9. Slide the flue pipe with the new terminal into the air pipe until you hear the terminal click into place.

Conditions: Terminal secured using screws

- Attach the terminal using the side screws.

5 Installation

5.3.3 Deflector set

5.3.3.1 Scope of delivery

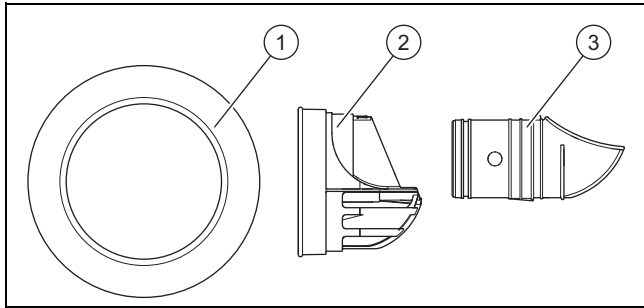

- | | | | |
|---|---------------|---|-----------|
| 1 | Wall collar | 3 | Deflector |
| 2 | Opening piece | | |

- Deflector set, DN 60, PP, black (article number 0020219533)
- Deflector set, DN 60, PP, white (article number 0020219534)

5.3.3.2 Installing the deflector set

Conditions: Replacing the deflector set (change of colour)

- ▶ In the event of a change of colour, replace the deflector set, including the wall collar (→ Page 14).
- ▶ Install the deflector, instead of the end pipe, on the opening piece.

Conditions: Replacing the end pipe only

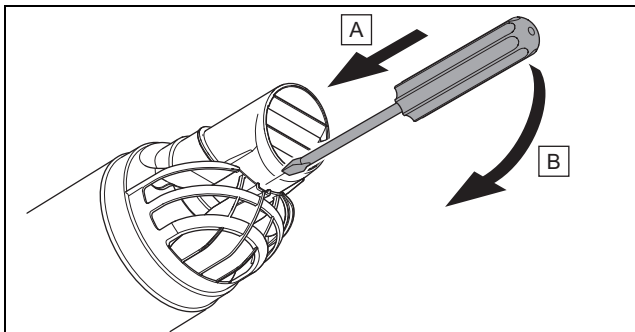

- ▶ Release the catch between the opening piece and the end pipe.

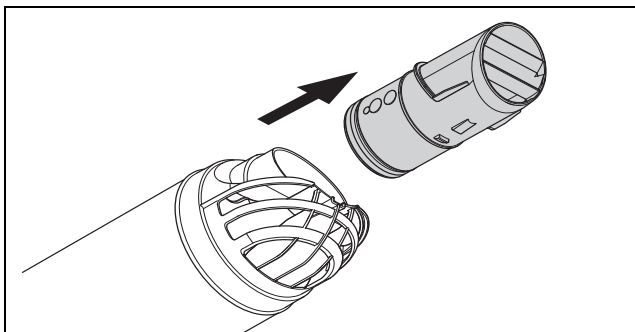

- ▶ Pull the end pipe from the opening piece.

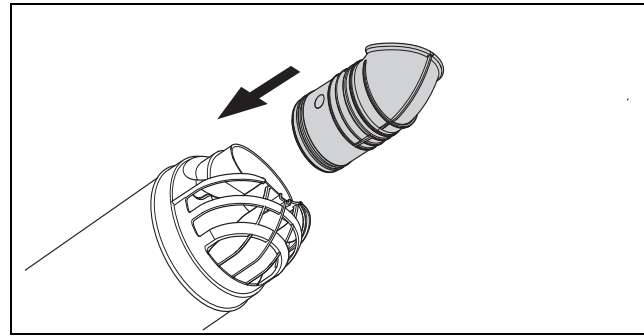

- ▶ Slide the deflector onto the opening piece until you hear the deflector click into place.

5.3.3.3 Adjusting the deflector

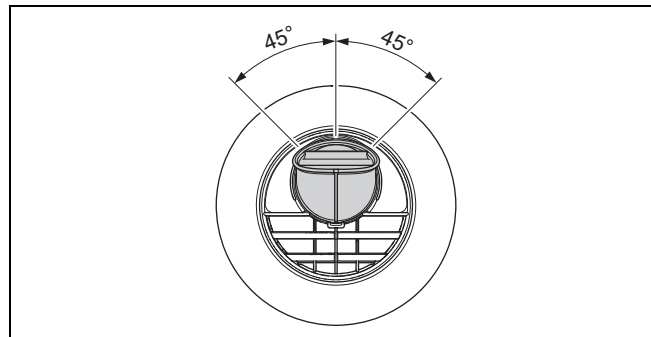

- ▶ Set the terminal to the required position.
 - The flue gas stream is directed upwards at an angle of approx. 45° when the deflector is set in the centre position.
 - If necessary, the deflector terminal can be rotated 45° to the left or right. These adjustment options mean that the flue gas pipe can be further optimised.

5.3.4 Variable terminal kit (VTK)

The variable terminal kit (VTK) must not be used for the following products:

- 835 (VUW 356/5-7 (H-GB))
- 843 (VUW 436/5-7 (H-GB))

5.3.4.1 Scope of delivery

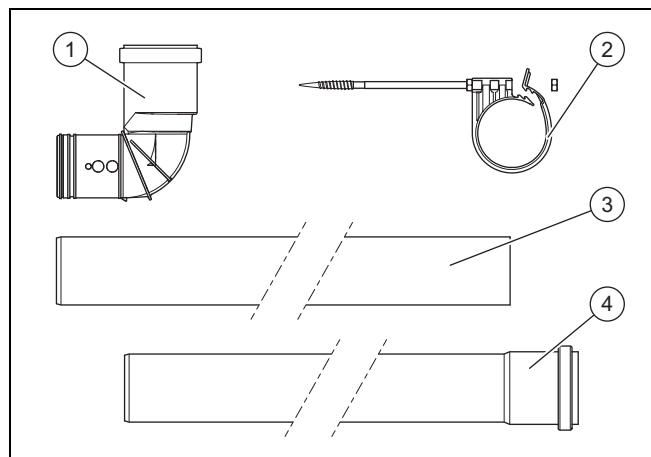

- | | | | |
|---|-------------------|---|--------------------------------|
| 1 | 87° elbow (2 x) | 3 | Extension (1 m) without sleeve |
| 2 | Pipe clamps (3 x) | 4 | Extension (1 m) with sleeve |

- Variable terminal kit, black, article number 0020219529
- Variable terminal kit, white, article number 0020219530

5.3.4.2 Installing the variable terminal kit (VTK)

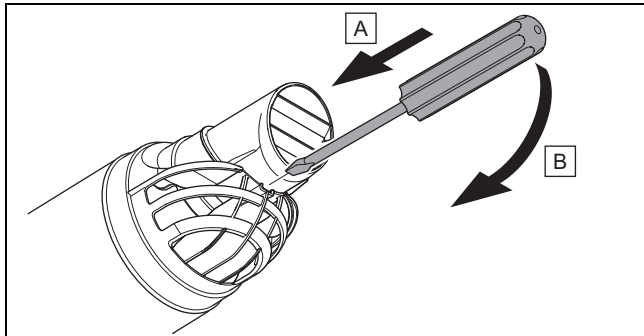

1. Release the catch between the opening piece and the end pipe.

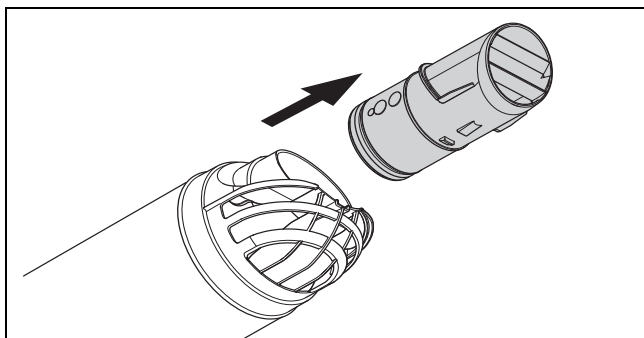

2. Pull the end pipe from the opening piece.

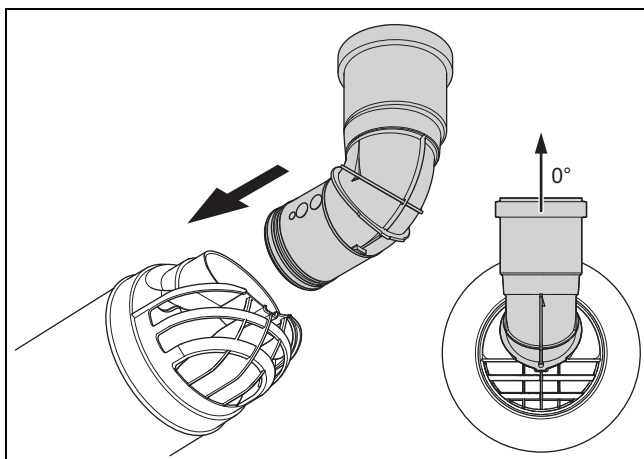

3. Slide the first 87° elbow onto the opening piece until you hear the 87° elbow click into place.

5.3.4.3 Installing extensions

1. Install the flue gas pipe from the 87° elbow to the flue outlet.
 - Begin with the extension with the sleeve. To be able to install the second 87° elbow with the end pipe, you must install the extension without a sleeve last.
 - Allow expansion space of 1 cm in each sleeve.
 - Ensure that all disconnection points are absolutely leak-tight.

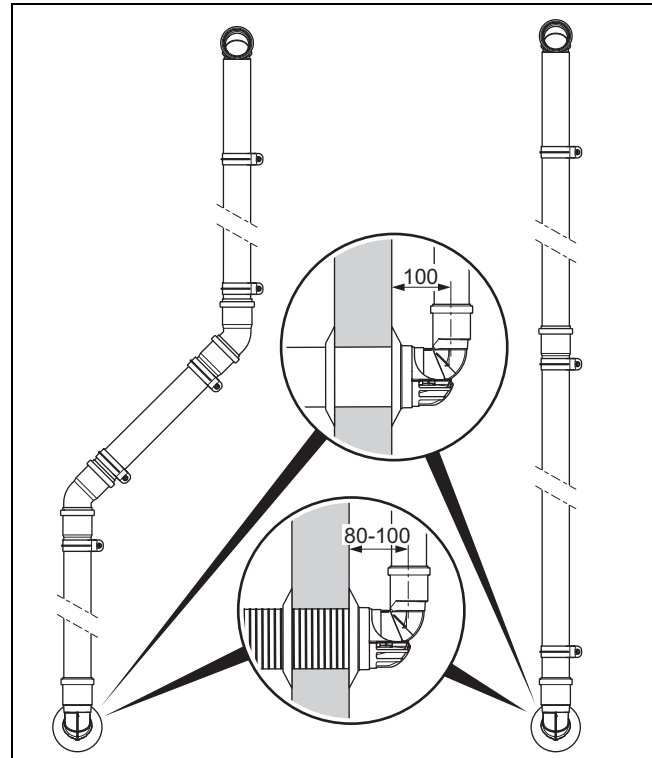

2. Secure the extensions to the wall using the pipe clamps.
 - Use one pipe clamp for each extension directly beside the sleeve.
 - Upstream of each elbow, install another pipe clamp on the extension.

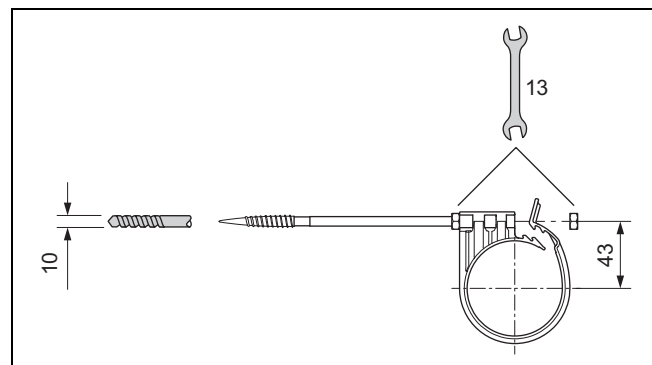

3. Drill the fastening holes away from the centre.

5 Installation

5.3.4.4 Installing the end pipe

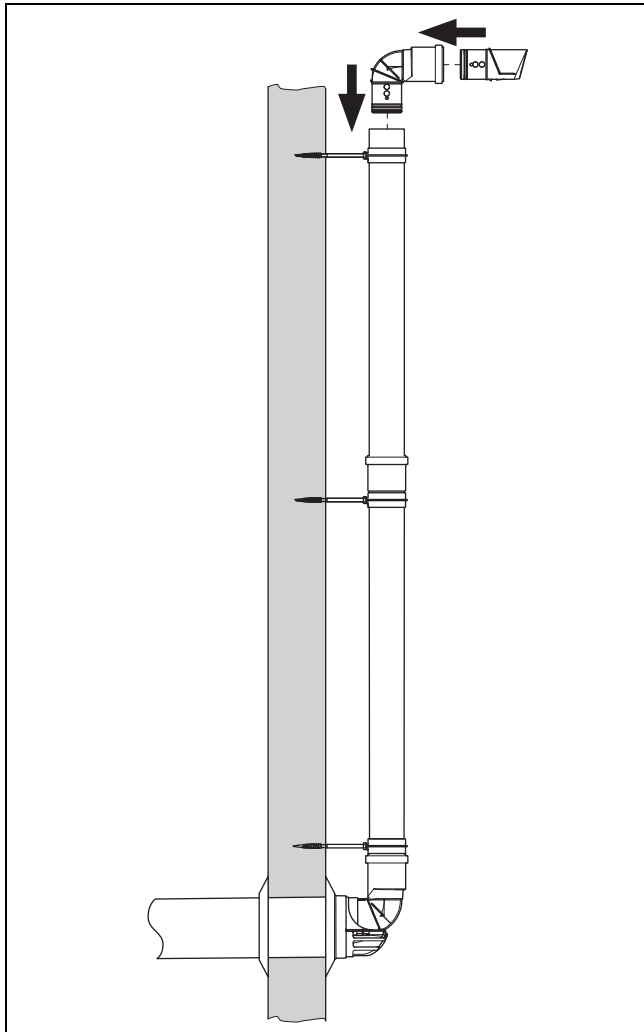

1. Install the second 87° elbow into the last extension.
2. Securely insert the end pipe into the 87° elbow until the end pipe clicks into place in the seal.

5.3.4.5 Routing extensions for the variable terminal kit around eaves

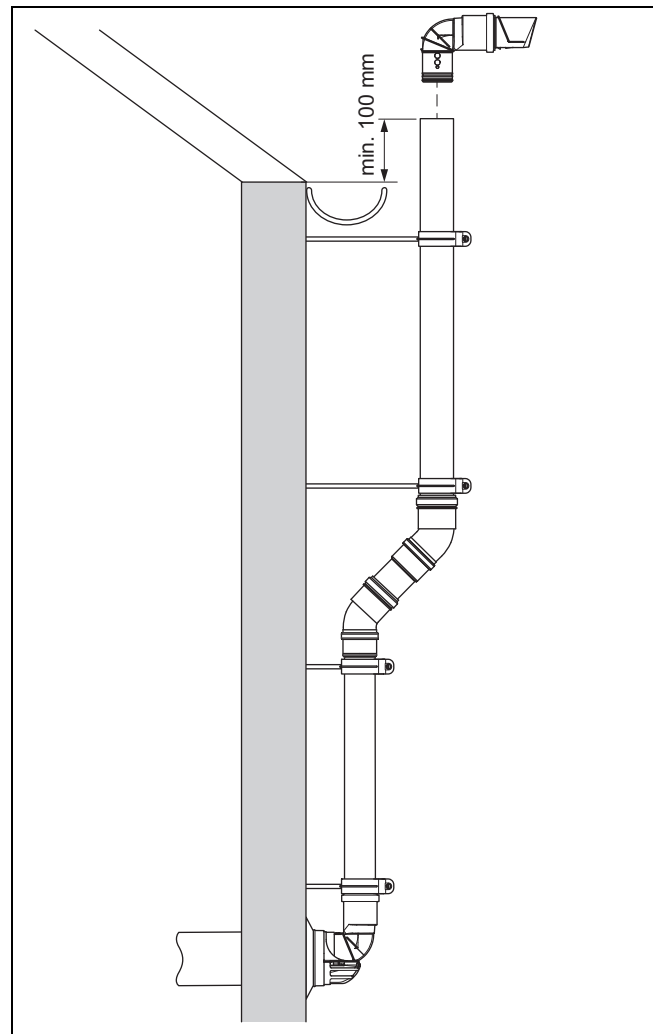

When installing the variable terminal kit around eaves, additional M8 threaded rods are required for the pipe clamps. The threaded rods are commercially available.

- If required, install additional 45° elbows.

5.3.5 Installing the 80/125 mm diameter horizontal wall or roof duct, article number 303209

5.3.5.1 Scope of delivery

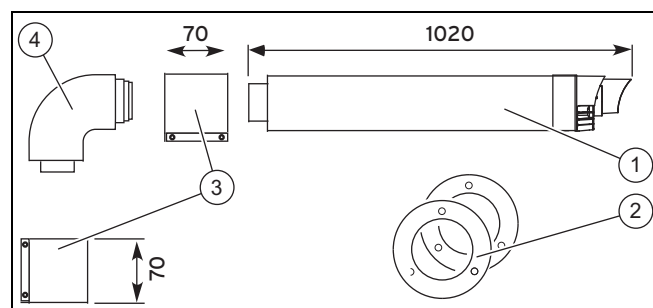

- | | | | |
|---|-----------------------------------|---|---------------------|
| 1 | Horizontal wall/roof duct | 3 | 70 mm clamp (2 pcs) |
| 2 | Wall collar, 125 diameter (2 pcs) | 4 | 87° elbow |

5.3.5.2 Installing the wall duct

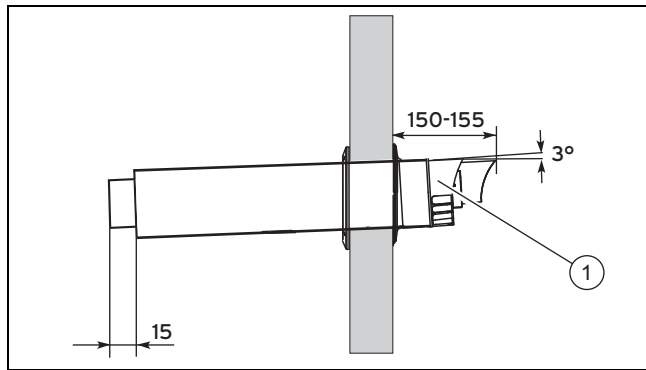

1. Drill a hole.
 - Diameter: 130 mm
2. Insert the flue pipe (1) into the wall opening.
3. Secure the flue pipe with mortar and leave the mortar to harden.
4. Install the wall collar on the inside and outside of the wall.

5.3.5.3 Installing the roof duct

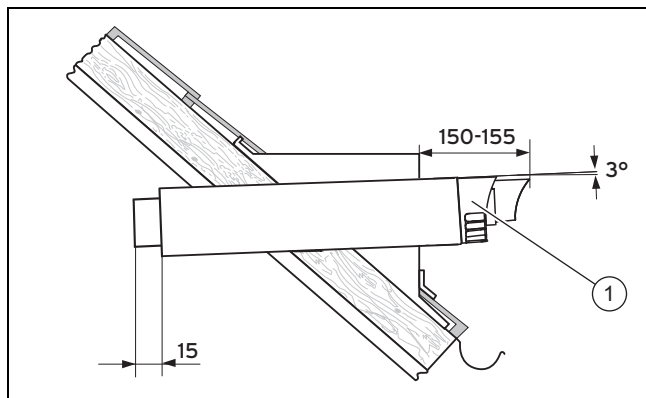

- ▶ Insert the air/flue pipe (1) without the external collar into the dormer.

5.3.5.4 Connecting the product

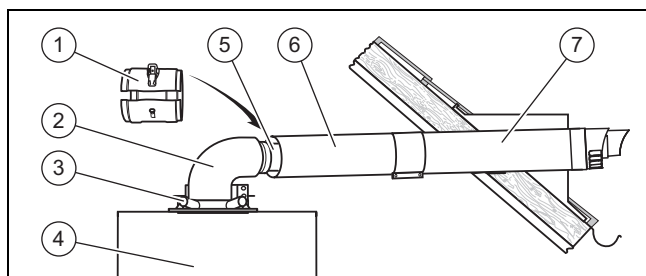

1. Install the product (4) – see the installation instructions for the product.
2. If required, replace the connection piece for the air/flue pipe (3), see the installation instructions for the product.
3. Connect the connection elbow (2) to the connection piece for the air/flue pipe (3).
4. Insert the partition (5) with the sleeve as far as it will go in the wall/roof duct (7) or the extension (6).
5. If required, install the extensions.
6. Connect the sliding sleeve to the connection elbow.
7. Install the air clamp (1) for the sliding sleeve.

8. Alternatives 1 / 2

Conditions: Wall/roof duct without extension

- ▶ Install the sliding sleeve. (→ Page 24)

8. Alternatives 2 / 2

Conditions: Wall/roof duct with extension

- ▶ Install the extensions. (→ Page 25)
- ▶ Install the 45° elbow. (→ Page 30)
- ▶ Install the 87° elbow. (→ Page 32)
- ▶ Install the sliding sleeve. (→ Page 24)
- ▶ Connect all of the disconnection points with air clamps. (→ Page 34)

5.4 Installing the vertical roof duct

5.4.1 Installation instructions



Danger!

Risk of poisoning due to escaping flue gas and risk of material damage due to the roof duct shearing off.

Snow and ice sliding down pitched roofs may break off the vertical roof duct where it exits the roof.

- ▶ In regions where heavy snow falls/extensive ice formation can be expected, install the vertical roof duct close to the ridge or install a snow guard mesh above the roof duct.

The vertical roof ducts can be shortened under the roof. However, to ensure that the fixing bracket is secured tightly, the lengths must still be sufficient.

- ▶ Shorten the flue pipe and the air pipe by the same length.

5.4.2 Installing the vertical roof duct, 60/100 mm diameter

5.4.2.1 Assembling the vertical roof duct



Note

When delivered, the lower pipe of the vertical roof duct is pushed into the upper pipe.

5 Installation

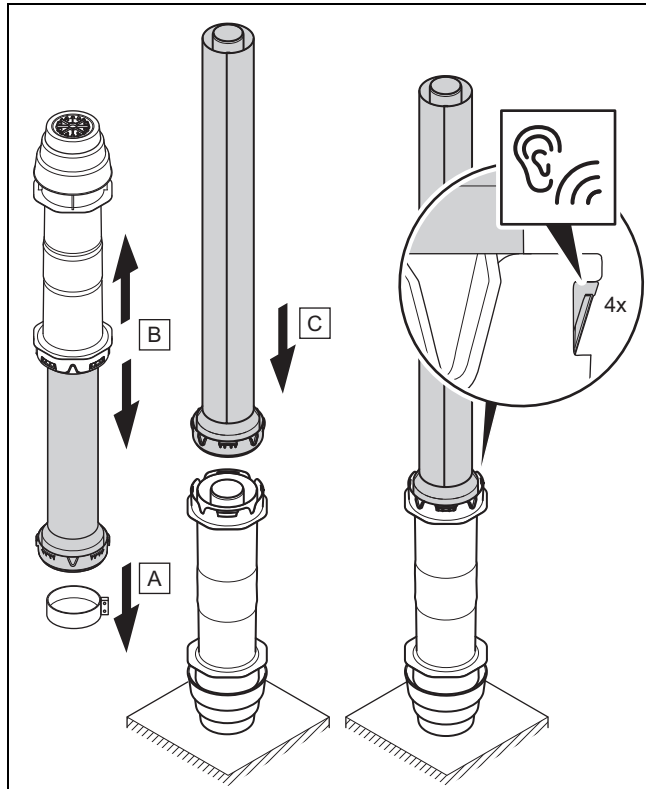

- ▶ Assemble the vertical roof duct.
 - Ensure that you hear the lower part click into place in the upper part.

5.4.2.2 Scope of delivery article number 0020223472 (black, with collar)

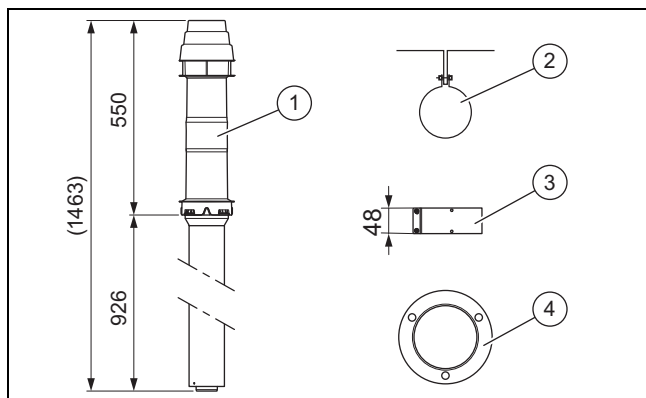

- | | | | |
|---|--------------------|---|-----------------------|
| 1 | Vertical roof duct | 3 | 48 mm air-pipe collar |
| 2 | Fixing bracket | 4 | Cover plate |

5.4.2.3 Installing the pitched-roof duct

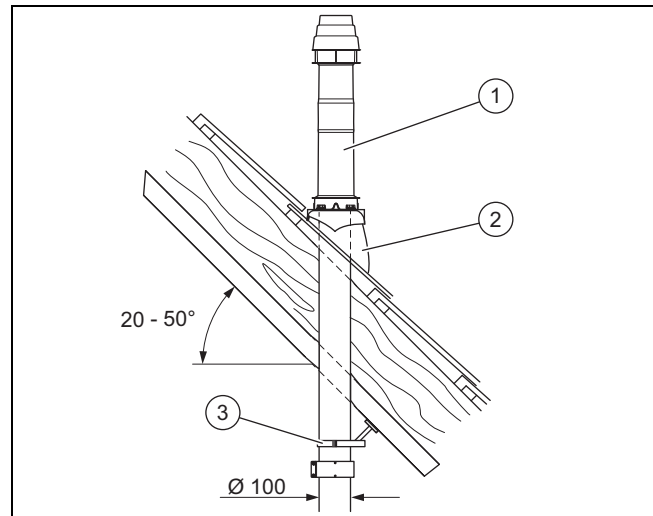

1. Determine the installation location of the roof duct so that there is sufficient distance behind the product in order to connect the product to the heating installation.
2. Insert the roof tile (2).
3. Insert the roof duct (1) through the pantile from above and push it down until the cover plate is flush.
4. Align the roof duct vertically.
5. Secure the roof duct to the roof construction using the fixing bracket (3).
6. Connect the roof duct to the product using extensions, elbows and, if required, a sliding sleeve. If you do not insert a sliding sleeve, you must always install the 40 mm clamp directly on the product.
7. **Alternatives 1 / 2**
 - Conditions:** Roof duct with extension
 - ▶ Install the extensions. (→ Page 25)
 - ▶ Install the 45° elbow. (→ Page 28)
 - ▶ Install the 87° elbow. (→ Page 29)
 - ▶ Install the sliding sleeve. (→ Page 24)
 - ▶ Connect all of the disconnection points with air clamps. (→ Page 34)

7. Alternatives 2 / 2

Conditions: Roof duct without extension

- ▶ Install the sliding sleeve. (→ Page 24)

5.4.2.4 Installing the flat-roof duct



Caution.

Risk of damage to the structure of the building.

As a result of improper installation, water may penetrate the building and cause material damage.

- ▶ Observe the definitions in the directives for the planning and implementation of roofs with seals.

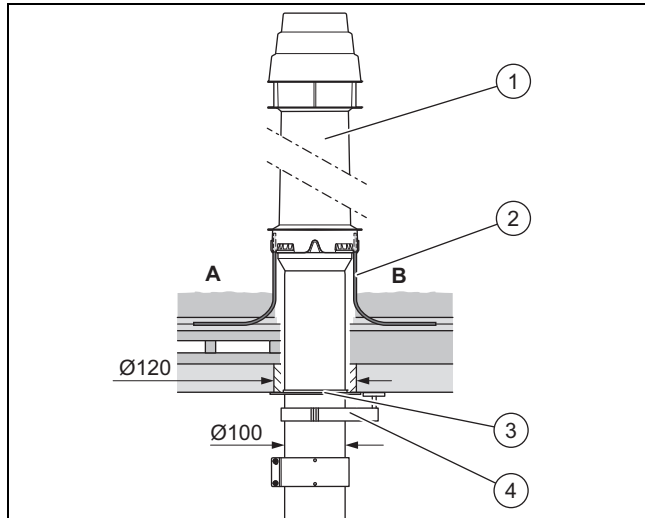

A Cold roof B Hot roof

1. Determine the installation site for the roof duct.
2. Insert the flat roof penetration collar (2).
3. Glue the flat roof penetration collar in place.
4. Insert the roof duct (1) through the flat roof penetration collar from above and push it down until it is flush.
5. Align the roof duct vertically.
6. Put the cover plate (3) on.
7. Secure the roof duct to the roof construction using the fixing bracket (4).
8. Connect the roof duct to the product using extensions, elbows and, if required, a partition. If you do not insert a partition, you must always install the 48 mm clamp directly on the product.

9. **Alternatives 1 / 2**

Conditions: Roof duct with extension

- ▶ Install the extensions. (→ Page 25)
- ▶ Install the 45° elbow. (→ Page 28)
- ▶ Install the 87° elbow. (→ Page 29)
- ▶ Install the sliding sleeve. (→ Page 24)
- ▶ Connect all of the disconnection points with air clamps. (→ Page 34)

9. **Alternatives 2 / 2**

Conditions: Roof duct without extension

- ▶ Install the sliding sleeve. (→ Page 24)

5.4.3 Installing the ridge tiles for the 60/100 mm diameter roof duct

5.4.3.1 Scope of delivery for article number 303982 (black)

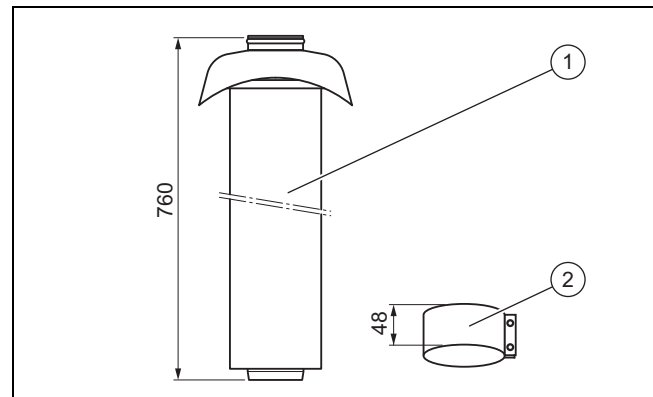

1 Ridge tile terminal, black 2 48 mm air-pipe collar

5.4.3.2 Ridge roof duct

According to the specifications from the tile manufacturer, a suitable ridge tile must be installed.

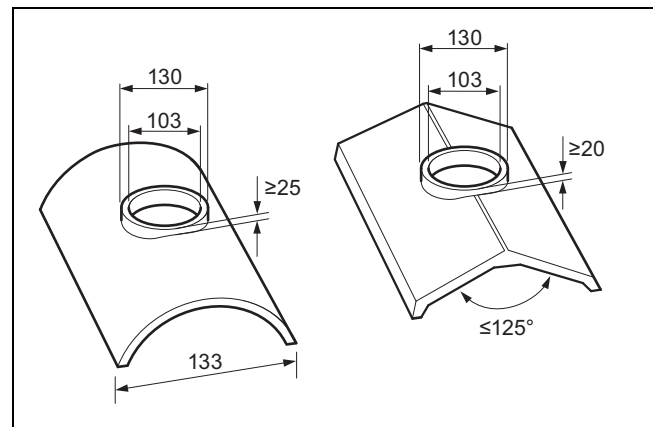

Suitable ridge tiles are manufactured by:

Aspect East Anglia Limited

The Old Mill

East Harling

NORWICH

NR16 2QW

Website: www.aspectroofing.co.uk

Contact: Chris Haythorpe

General Manager – Tile Division

Tel: +44 (0) 1953 717777 Fax: +44 (0) 1953 717164

5 Installation

5.4.3.3 Installing the ridge tile terminal

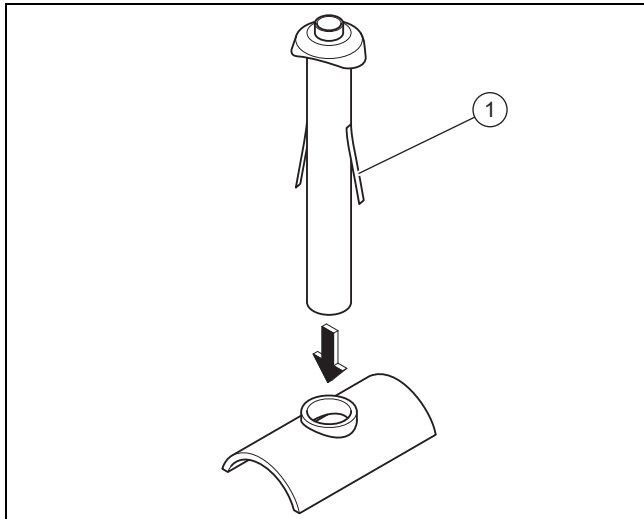

1. Install the ridge tile in accordance with the specifications from the tile manufacturer.
2. Insert the ridge tile terminal into the ridge tile.
3. Align the ridge tile terminal in such a way that the two fixing tabs (1) are at a right angle to the course of the ridging. This ensures that the combustion air can be extracted from between the ridge tile and the air hood above the ridge tile.

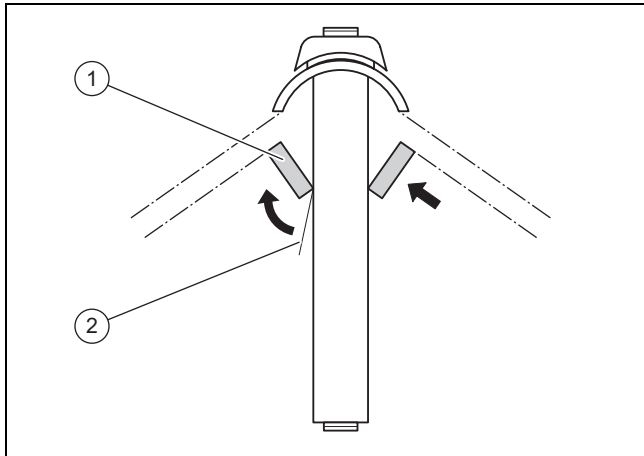

4. Bend the two fixing tabs (2) on one bar (1).
5. Use nails or screws to secure the fixing tabs.
6. Install the boiler (→ Installation instructions for the boiler).
7. Install the extensions. (→ Page 25)
8. Install the 45° elbow. (→ Page 28)
9. Install the 45° elbow. (→ Page 28)
10. Connect all of the disconnection points with air clamps. (→ Page 34)
11. Connect the ridge tile terminal and the boiler to extensions and elbows.

5.4.4 Installing the vertical roof duct, 80/125 mm diameter

5.4.4.1 Scope of delivery article number 303200 (black)

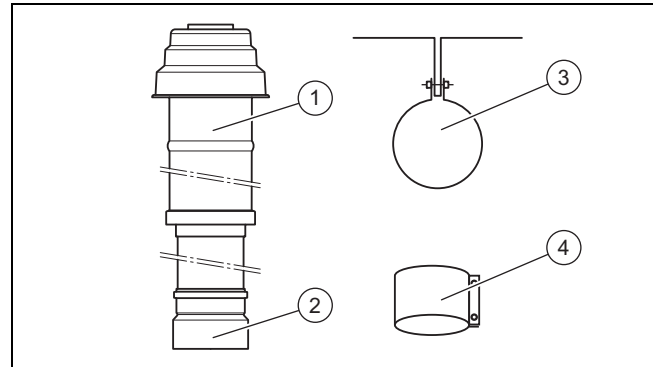

- | | | | |
|---|------------------------------------|---|-----------------------|
| 1 | Vertical roof duct | 3 | Fixing bracket |
| 2 | Adaptor (air) for 110/125 diameter | 4 | 70 mm air-pipe collar |

5.4.4.2 Installing the pitched-roof duct

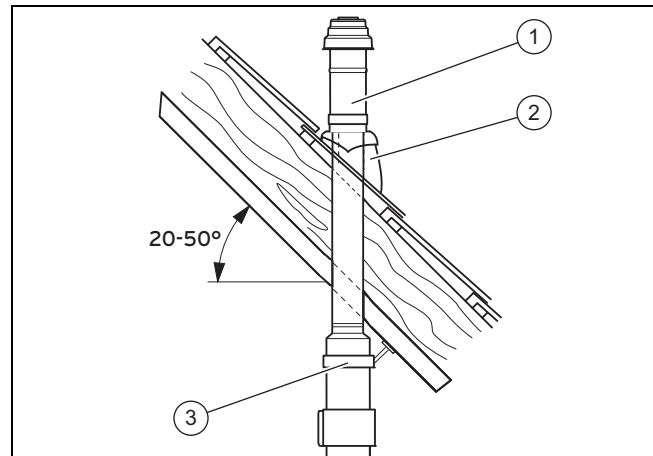

1. Determine the installation site of the roof duct in such a way that there is sufficient distance behind the product in order to connect the product to the heating installation.
2. Insert the roof tile (2).
3. Insert the roof duct (1) through the roof tile from above and push it down until it is flush.
4. Align the roof duct vertically.
5. Secure the roof duct to the roof construction using the fixing bracket (3).
6. Connect the roof duct to the product using extensions, elbows and, if required, a sliding sleeve.
7. **Alternatives 1 / 2**

Conditions: Roof duct with extension

- ▶ Install the extensions. (→ Page 25)
- ▶ Install the 45° elbow. (→ Page 30)
- ▶ Install the 87° elbow. (→ Page 32)
- ▶ Install the sliding sleeve. (→ Page 24)
- ▶ Connect all of the disconnection points with air clamps. (→ Page 34)

7. Alternatives 2 / 2

Conditions: Roof duct without extension

- ▶ Install the sliding sleeve. (→ Page 24)

5.4.4.3 Installing the flat-roof duct



Caution.

Risk of damage to the structure of the building.

As a result of improper installation, water may penetrate the building and cause material damage.

- ▶ Observe the definitions in the directives for the planning and implementation of roofs with seals.

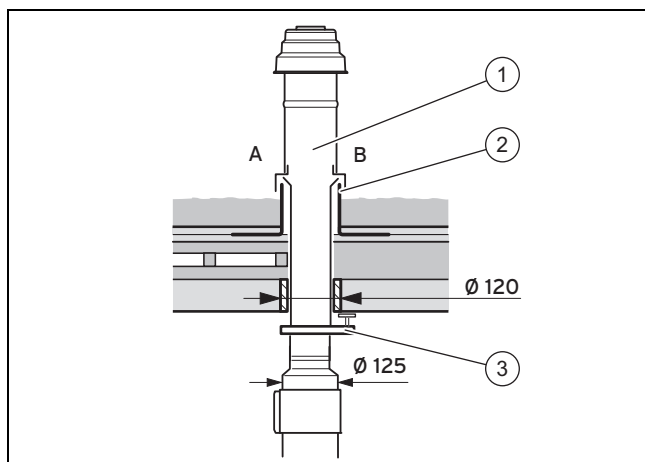

A Cold roof B Hot roof

1. Determine the installation site for the roof duct.
2. Insert the flat roof penetration collar (2).
3. Glue the flat roof penetration collar in place.
4. Insert the roof duct (1) through the flat roof penetration collar from above and push it down until it is flush.
5. Align the roof duct vertically.
6. Secure the roof duct to the roof construction using the fixing bracket (3).
7. Connect the roof duct to the product using extensions, elbows and, if required, a sliding sleeve.

8. Alternatives 1 / 2

Conditions: Roof duct with extension

- ▶ Install the extensions. (→ Page 25)
- ▶ Install the 45° elbow. (→ Page 30)
- ▶ Install the 87° elbow. (→ Page 32)
- ▶ Install the sliding sleeve. (→ Page 24)
- ▶ Connect all of the disconnection points with air clamps. (→ Page 34)

8. Alternatives 2 / 2

Conditions: Roof duct without extension

- ▶ Install the sliding sleeve. (→ Page 24)

5.5 Installing the concentric connection, 60/100 mm diameter, to the air/flue gas system for negative pressure

5.5.1 Installation instructions

Installation example:

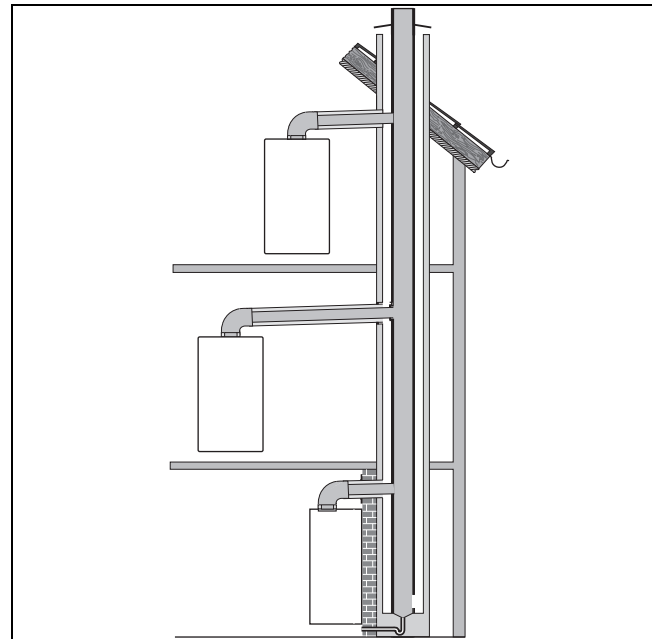

Markings have been assigned to the air/flue gas system in accordance with EN 1443 and these indicate that the system complies with the fundamental requirements of the construction products directive. The air/flue gas system is not approved as part of the boiler.

The air/flue gas chimney must be designed and approved for negative-pressure operation by the manufacturer.

The air/flue gas chimney's identification plate is marked for operation with condensing units and a flue gas temperature of at least 120 °C.

- ▶ Take into consideration the regulations with regard to fire resistance.

The Vaillant ecoTEC gas-fired wall-hung boilers that are mentioned in these installation instructions are approved in accordance with the European and British standard "PD CEN/TR 1749: 2005, European scheme for the classification of gas appliances according to the method of evacuation of the combustion products (types) C43".

The length of the air/flue pipe must not exceed 1.4 m and three elbows. This corresponds to a maximum length of 3.4 m for the C43 connection.

5 Installation

5.5.2 Components that are suitable for connection

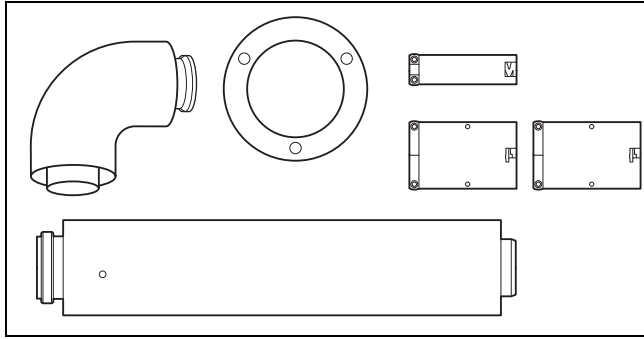

- 87° elbow (article number 303910)
- Extensions
 - 470 mm (article number 303902)
 - 970 mm (article number 303903)
 - 970 mm (article number 303905)
- Air clamps (article number 303821)

5.5.3 Installing a connection to air/flue gas system



Caution.
Risk of damage to the product.

There must not be any overpressure in the vertical part of the flue gas installation, because, in this case, the burner may pulse and the product may become damaged. The product is not suitable for this mode of operation and has not been checked.

- ▶ Provide evidence of the functional reliability of the vertical flue gas pipe in accordance with EN-13384 using the specifications for flue gas temperature and flue gas mass rate from the installation instructions for the product.



Caution.
Risk of damage to the structure of the building.

The static function and fire-protective function of the shaft wall may be impaired by fastenings.

- ▶ Do not attach any fastenings using bolts, rawl plugs, etc. directly to the shaft wall of the air/flue gas system.
- ▶ Do not attach fastenings to primary walling or sideways to the wall.
- ▶ Observe the specifications provided by the manufacturer of the air/flue gas system.

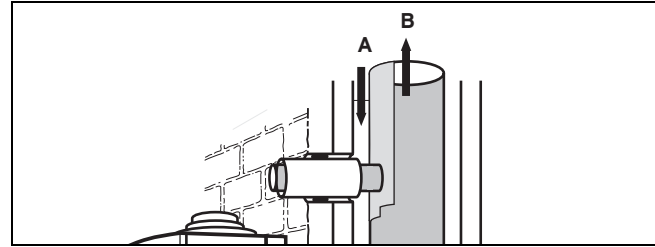

A Air B Flue gas

- ▶ On the air/flue gas system, establish a connection for open-flued operation.
 - Connection height for the product (including the connection piece for the air/flue pipe and inspection elbow), see the installation instructions for the product.

5.5.4 Connecting the product to the air/flue gas system

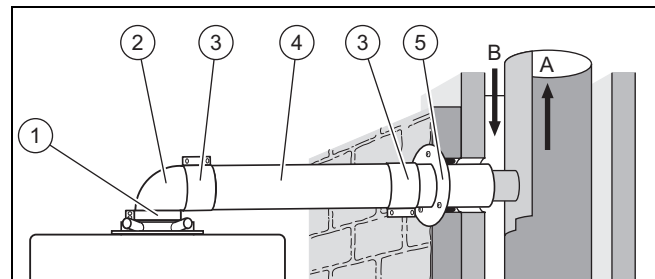

1. Install the product (→ Installation instructions for the product).
2. Slide the wall collar (5) onto the air pipe.
3. Install the extension (4) and the elbow (2) between the connection piece for the flue gas pipe.
4. Install the 40 mm air clamp (1). When doing so, ensure that it is aligned centrally.
5. Install the 70 mm air clamps (3). When doing so, ensure that it is aligned centrally.
6. Connect all of the disconnection points with air clamps (1).

Conditions: Additional extensions and elbows required

- ▶ Install the extensions. (→ Page 25)
- ▶ Install the 45° elbow. (→ Page 28)
- ▶ Install the 87° elbow. (→ Page 29)
- ▶ Connect all of the disconnection points with air clamps. (→ Page 34)

5.6 Installing the sliding sleeve, elbows and extensions

5.6.1 Installing the sliding sleeve



Note

The sliding sleeve provides for straightforward installation and disconnection of the air/flue pipe to/from the product.

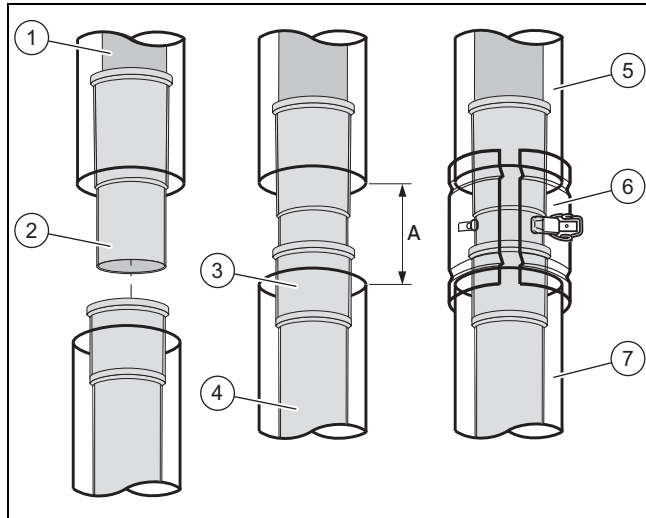

- Slide the sliding sleeve (2) onto the flue pipe (1) as far as it goes.
- Pull the sliding sleeve (2) back far enough from the flue pipe (1) so that the inserting end of the sliding sleeve sits in the sleeve (3) of the flue pipe (4).

	60/100 mm diameter	80/125 mm diameter
A	100-110 mm	82-90 mm

- Connect the air pipes (5, 7) with the air clamp (6).



Danger!
Risk of poisoning due to escaping flue gas.

Flue gas can escape if the flue pipe is damaged.

- ▶ Take care that the flue pipe is not damaged when drilling.

- Drill two holes through the air clamp and the air pipe.
 - Diameter: 3 mm
 - Clearance from the outside of the air clamp: 6 mm



Danger!
Risk of poisoning due to escaping flue gas.

Flue gases may escape as a result of pipes that are not securely connected to each other.

- ▶ Secure the clamps and the air pipes using the supplied screws.

- Insert the safety screws.

5.6.2 Installing extensions



Danger!
Risk of poisoning due to escaping flue gas.

The flue pipes of the flue pipework may move as a result of thermal expansion and may then become disconnected.

- ▶ Lock the flue pipe in the spacer of the air pipe.



Note
 To cut the air and flue pipes to length separately, you can dismantle the pre-assembled extensions without the use of any tools.

Installing 60/100 mm diameter extensions

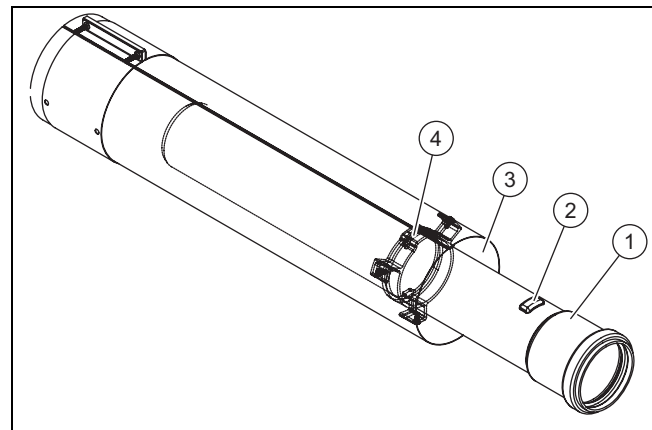

- Turn the flue pipe (1) to a position that enables the ridge (2) on the plastic pipe to be pushed through the spacer (4).
- Pull the pipe quickly and firmly over the detent.

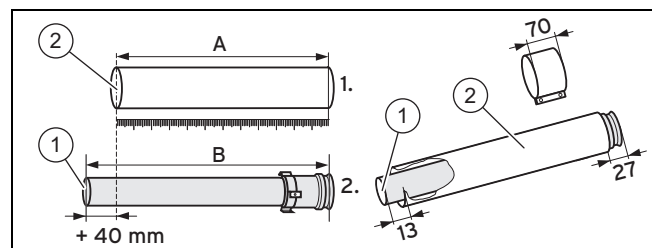

- First, measure the required air pipe length* (A) and then calculate from that the corresponding flue gas pipe length (B) in each case:
 - Length of the flue pipe: Length of the air pipe + 40 mm
 - Minimum length of air-pipe extension: 80 mm.
- Shorten the pipes, e.g. with a saw.
- After shortening, lock the flue gas pipe (1) in the air pipe (2) again by pushing it in again and turning it as far as it goes.

5 Installation

Installing 80/125 mm diameter extensions

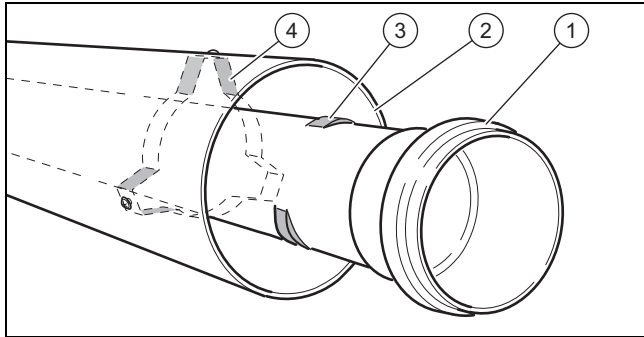

6. Turn the flue pipe (1) to a position that enables the ledges (3) on the plastic pipe to be pushed through the spacer (4).
7. Pull the flue pipe out of the air pipe (2).

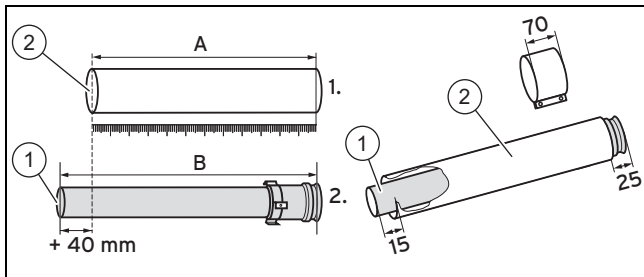

8. First, measure the required air pipe length* (A) and then calculate from that the corresponding flue gas pipe length (B) in each case:
 - Length of the flue pipe: Length of the air pipe + 40 mm
 - * Minimum length of air-pipe extension: 100 mm.
9. Cut the pipes with a saw, panel shears, etc.
10. After shortening, lock the flue pipe (1) inside the air pipe (2) again.

5.6.3 Installing elbows (white)

5.6.3.1 Correctly aligning the elbows



Danger!
Risk of poisoning due to escaping flue gas.

Unnecessary loading on the connections may cause leaks.

- ▶ Align the elbows correctly.

- ▶ Observe the following illustrations when using two 87° elbows.

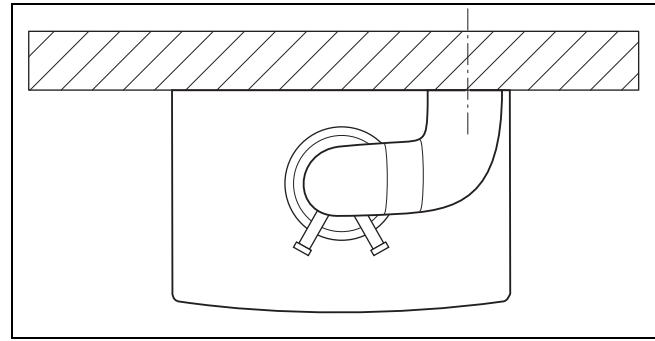

Arrangement of the 2 x 87° elbows – View from above

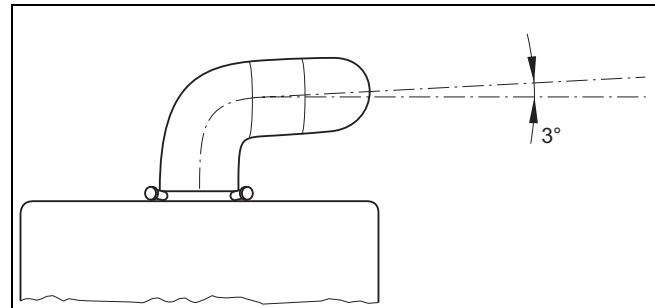

Arrangement of the 2 x 87° elbows – View from the front

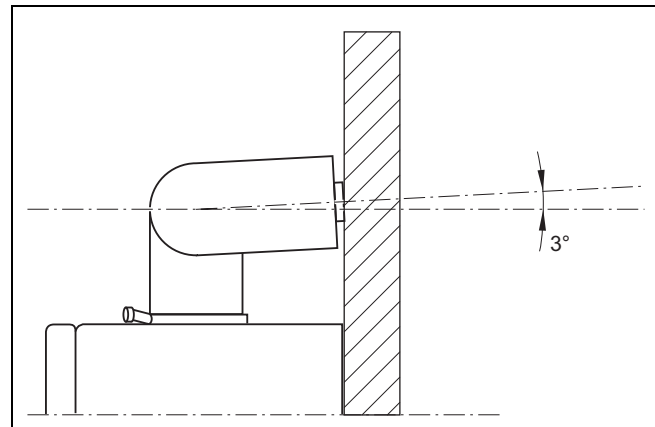

Arrangement of the 2 x 87° elbows – View from the side

- ▶ When using elbows to route long flue gas pipes in a corner, observe the following illustrations.

Connecting extensions with 87° elbows

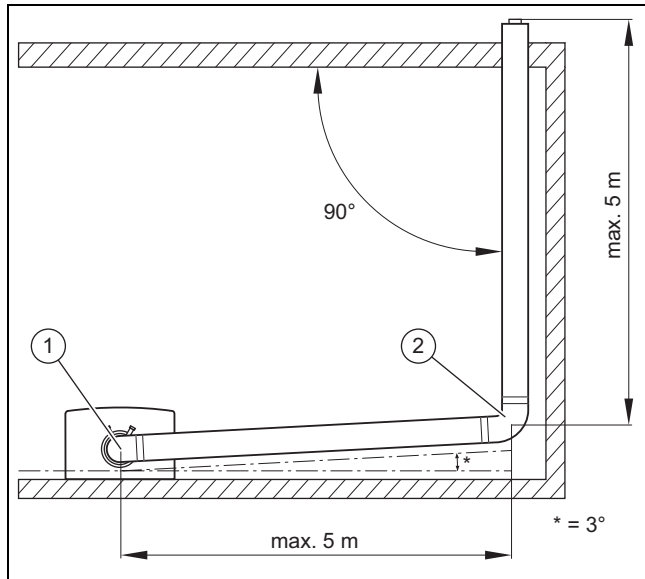

- ▶ To ensure that you can guide a second 87° elbow (2) at a right angle through the wall, install the elbow (1) on the top of the boiler, at a 3° rotation.

Connecting extensions with 45° elbows

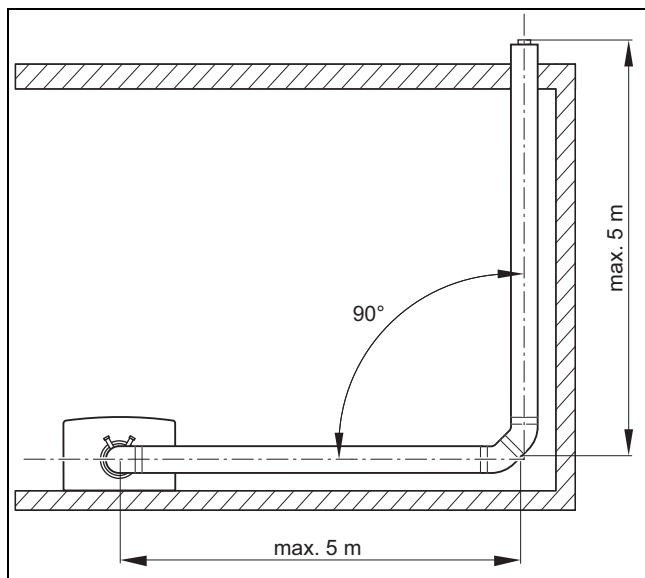

- ▶ Install an 87° elbow at an angle of 3° between the wall and the air/flue gas line or use two 45° elbows.
- ▶ Connect all of the disconnection points with air clamps. (→ Page 34)

5 Installation

5.6.3.2 Installing the 45° elbow, 60/100 mm diameter

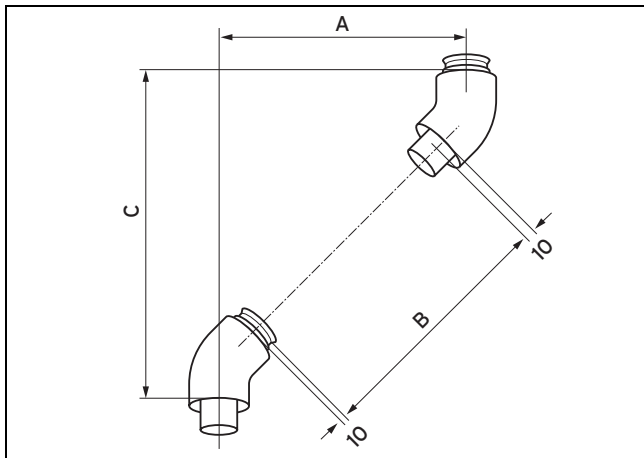

A Offset

C Height

B Length of the air pipe

1. Measure the offset (**A**), e.g. with 300 mm.
Table of offset dimensions (→ Page 28)
2. Use this value from the table to determine the length of the air pipe (**B**) = 284 mm and the height (**C**) = 420 mm.
◁ From that, the corresponding flue gas pipe length is calculated as $284 + 40 = 324$ mm.

Offset	Length of the air pipe	Height	Offset	Length of the air pipe	Height in	Offset	Length of the air pipe	Height in
90	0	210	325	320	445	525	602	645
95	0	215	330	327	450	530	610	650
100	0	220	335	334	455	535	617	655
> 105 to < 155	not possible	not possible	340	341	460	540	624	660
			345	348	465	545	631	665
			350	355	470	550	638	670
			355	362	475	555	645	675
160	86	280	360	369	480	560	652	680
165	93	285	365	376	485	565	659	685
170	100	290	370	383	490	570	666	690
175	107	295	375	390	495	575	673	695
180	115	300	380	397	500	580	680	700
185	122	305	385	404	505	585	687	705
190	129	310	390	412	510	590	694	710
195	136	315	395	419	515	595	701	715
200	143	320	400	426	520	600	709	720
205	150	325	405	433	525	605	716	725
210	157	330	410	440	530	610	723	730
215	164	335	415	447	535	615	730	735
220	171	340	420	454	540	620	737	740
225	178	345	425	461	545	625	744	745
230	185	350	430	468	550	630	751	750
235	192	355	435	475	555	635	758	755
240	199	360	440	482	560	640	765	760
245	206	365	445	489	565	645	772	765
250	214	370	450	496	570	650	779	770
255	221	375	455	503	575	655	786	775
260	228	380	460	511	580	660	793	780
265	235	385	465	519	585	665	800	785

Offset	Length of the air pipe	Height	Offset	Length of the air pipe	Height in	Offset	Length of the air pipe	Height in
270	242	390	470	525	590	670	808	790
275	249	395	475	532	595	675	815	795
280	256	400	480	539	600	680	822	800
285	263	405	485	546	605			
290	270	410	490	553	610			
295	277	415	495	560	615			
300	284	420	500	567	620			
305	291	425	505	574	625			
310	298	430	510	581	630			
315	306	435	515	588	635			
320	313	440	520	595	640			

5.6.3.3 Installing the 87° elbow, 60/100 mm diameter

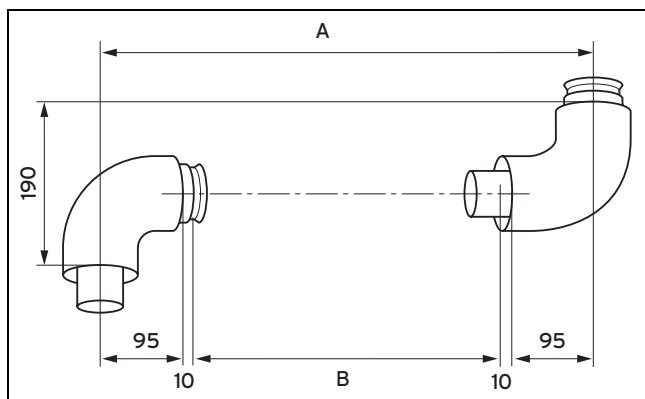

A Offset

B Length of the air pipe

1. Measure the offset (**A**), e.g. with 400 mm.
Table of offset dimensions (→ Page 29)
2. Use this value from the table to determine the length of the air pipe (**B**) = 190 mm.
◁ From that, the corresponding flue gas pipe length is calculated as 190 + 40 = 230 mm

Offset	Length of the air pipe	Offset	Length of the air pipe	Offset	Length of the air pipe
> 190 to < 210	0	470	260	690	480
		475	265	695	485
		480	270	700	490
> 215 to < 265	not possible	485	275	705	495
		490	280	710	500
		495	285	715	505
> 270 to < 290	80	500	290	720	510
		505	295	725	515
		510	300	730	520
295	85	515	305	735	525
300	90	520	310	740	530
305	95	525	315	745	535
310	100	530	320	750	540
315	105	535	325	755	545
320	110	540	330	760	550
325	115	545	335	765	555
330	120	550	340	770	560

5 Installation

Offset	Length of the air pipe	Offset	Length of the air pipe	Offset	Length of the air pipe
335	125	555	345	775	565
340	130	560	350	780	570
345	135	565	355	785	575
350	140	570	360	790	580
355	145	575	365	795	585
360	150	580	370	800	590
365	155	585	375		
370	160	590	380		
375	165	595	385		
380	170	600	390		
385	175	605	395		
390	180	610	400		
395	185	615	405		
400	190	620	410		
405	195	625	415		
410	200	630	420		
415	205	635	425		
420	210	640	430		
425	215	645	435		
430	220	650	440		
435	225	655	445		
440	230	660	450		
445	235	665	455		
450	240	670	460		
455	245	675	465		
460	250	680	470		
465	255	685	475		

5.6.3.4 Installing the 45° elbow, 80/125 mm diameter

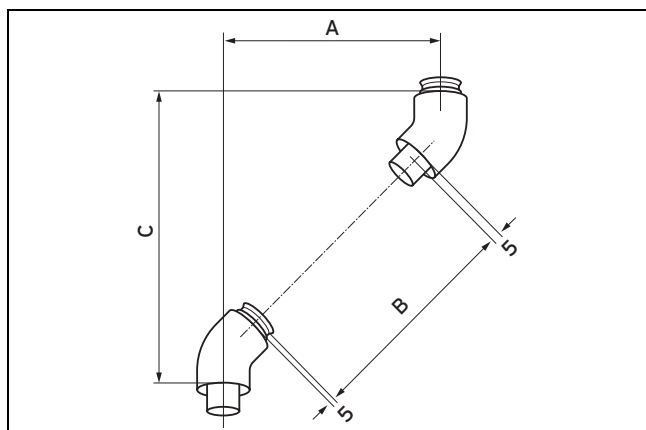

A Offset

B Length of the air pipe

C Height

1. Measure the offset (**A**), e.g. with 300 mm.

Table of offset dimensions (→ Page 31)

2. Use this value from the table to determine the length of the air pipe (**B**) = 294 mm and the height (**C**) = 420 mm.

◁ From that, the corresponding flue gas pipe length is calculated as $294 + 40 = 334$ mm.

Offset	Length of the air pipe	Height	Offset	Length of the air pipe	Height in	Offset	Length of the air pipe	Height in
85	-10	205	330	337	450	535	627	655
90	-3	210	335	344	455	540	634	660
95	4	215	340	351	460	545	641	665
100	11	220	345	358	465	550	648	670
> 100 to < 170	not possible	not possible	350	365	470	555	655	675
			355	372	475	560	662	680
			360	379	480	565	669	685
			365	386	485	570	676	690
165	103	285	370	393	490	575	683	695
170	110	290	375	400	495	580	690	700
175	117	295	380	407	500	585	697	705
180	125	300	385	414	505	590	704	710
185	132	305	390	422	510	595	711	715
190	139	310	395	429	515	600	719	720
195	146	315	400	436	520	605	726	725
200	153	320	405	443	525	610	733	730
205	160	325	410	450	530	615	740	735
210	167	330	415	457	535	620	747	740
215	174	335	420	464	540	625	754	745
220	181	340	425	471	545	630	761	750
225	188	345	430	478	550	635	768	755
230	195	350	435	485	555	640	775	760
235	202	355	440	492	560	645	782	765
240	209	360	445	499	565	650	789	770
245	216	365	450	506	570	655	796	775
250	224	370	455	513	575	660	803	780
255	231	375	460	520	580	665	810	785
260	238	380	465	528	585	670	818	790
265	245	385	470	535	590	675	825	795
270	252	390	475	542	595	680	832	800
275	259	395	480	549	600	685	839	805
280	266	400	485	556	605	690	846	810
285	273	405	490	563	610	695	853	815
290	280	410	495	570	615	700	860	820
295	287	415	500	577	620	705	867	825
300	294	420	505	584	625	710	874	830
305	301	425	510	591	630	715	881	835
310	308	430	515	598	635	720	888	840
315	315	435	520	605	640	725	895	845
320	323	440	525	612	645	730	902	850
325	330	445	530	620	650	-	-	-

5 Installation

5.6.3.5 Installing the 87° elbow, 80/125 mm diameter

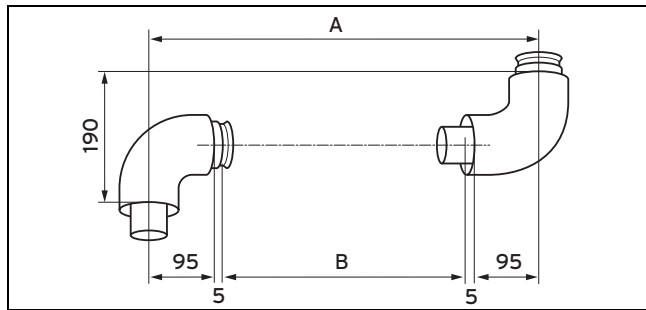

A Offset

B Length of the air pipe

1. Measure the offset (**A**), e.g. with 400 mm.
Table of offset dimensions (→ Page 32)
2. Use this value from the table to determine the length of the air pipe (**B**) = 200 mm.
 ◁ From that, the corresponding flue gas pipe length is calculated as $200 + 40 = 240$ mm

Offset	Length of the air pipe	Offset	Length of the air pipe	Offset	Length of the air pipe
190	0	500	300	735	535
195	0	505	305	740	540
200	0	510	310	745	545
> 200 to < 300	not possible	515	315	750	550
		520	320	755	555
		525	325	760	560
		530	330	765	565
300	100	535	335	770	570
305	105	540	340	775	575
310	110	545	345	780	580
315	115	550	350	785	585
320	120	555	355	790	590
325	125	560	360	795	595
330	130	565	365	800	600
335	135	570	370	805	605
340	140	575	375	810	610
345	145	580	380	815	605
350	150	585	385	820	620
355	155	590	390	825	625
360	160	595	395	830	630
365	165	600	400	835	635
370	170	605	405	840	640
375	175	610	410	845	645
380	180	615	415	850	650
385	185	620	420	855	655
390	190	625	425	860	660
395	195	630	430	865	665
400	200	635	435	870	670
405	205	640	440	875	675
410	210	645	445	880	680
415	215	650	450	885	685
420	220	655	455	890	690
425	225	660	460	895	695

Offset	Length of the air pipe	Offset	Length of the air pipe	Offset	Length of the air pipe
430	230	665	465	900	700
435	235	670	470	905	705
440	240	675	475	910	710
445	245	680	480	915	715
450	250	685	485	920	720
455	255	690	490	925	725
460	260	695	495	930	730
465	265	700	500	935	735
470	270	705	505	940	740
475	275	710	510	945	745
480	280	715	515	950	750
485	285	720	520	955	755
490	290	725	525	960	760
495	295	730	530	-	-

5 Installation

5.6.4 Installing the air clamps

1. Connect all of the disconnection points with air clamps.

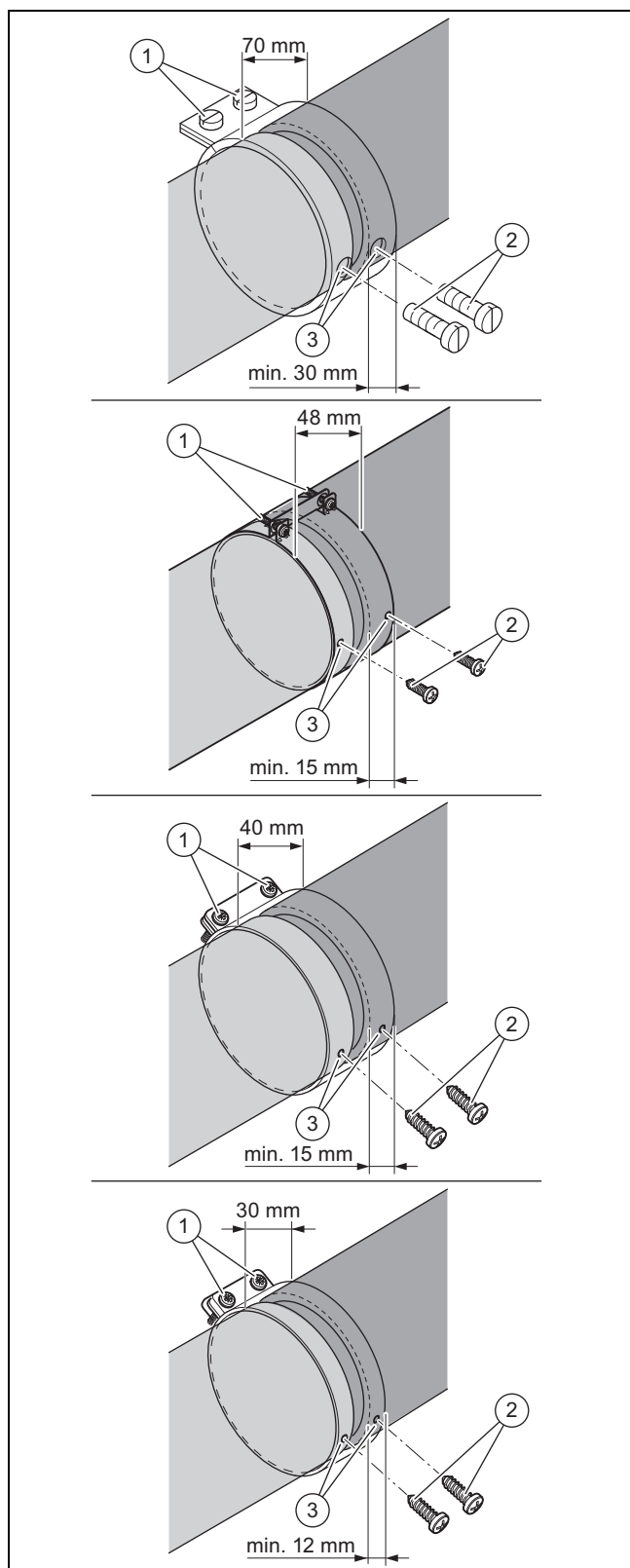

2. Slide the air clamps centrally over the disconnection point of the air pipes and tighten the screws (1).

- Air pipes distance: ≤ 5 mm



Danger!
Risk of poisoning due to escaping flue gas.

Flue gas can escape if the flue pipe is damaged.

- Take care that the flue pipe is not damaged when drilling.

3. Drill holes into the air pipe through the holes in the air clamp (3).



Danger!
Risk of poisoning due to escaping flue gas.

Flue gases may escape as a result of pipes that are not securely connected to each other.

- Secure the clamps and air pipes using the supplied bolts.

4. Insert the safety screws (2).

5.6.5 Securing the telescopic extension

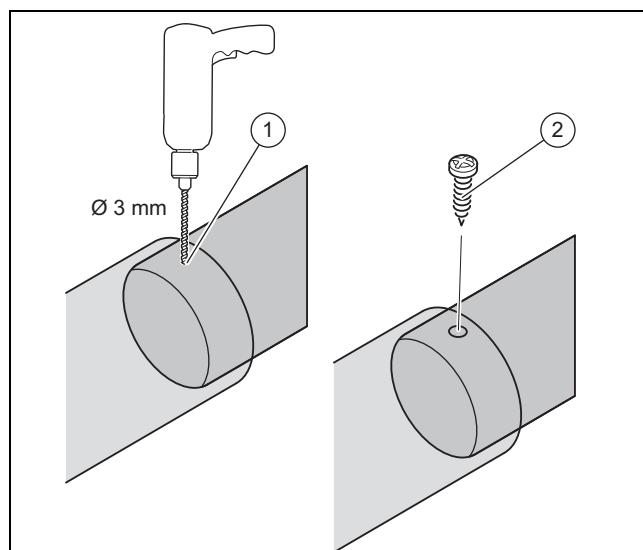

Danger!
Risk of poisoning due to escaping flue gas.

Flue gas can escape if the flue pipe is damaged.

- Take care that the flue pipe is not damaged when drilling.

1. Drill a hole (1) into the overlapping air pipes.

- Diameter: 3 mm
- 2. Use the screw **(2)** to screw in the air pipes.

6 Customer service

To ensure regular servicing, it is strongly recommended that arrangements are made for a Maintenance Agreement. Please contact Vaillant Service Solutions for further details:

Telephone: 0330 100 3461

Index

Index

A

Adjusting the deflector	16
Air/flue gas system	23–24
Air/flue gas system, installing a connection.....	24
Assembling the vertical roof duct, 60/100 mm diameter	19

B

Black terminal	14
----------------------	----

C

CE certification	5
Change of colour	14, 16
Channel vent, minimum clearances	4
Clearance from the external wall.....	12
Competent person	3
Correctly aligning the elbows	26

D

Deflector set	16
Disposing of condensate	9
Documents	6

E

Eaves	18
End pipe	14, 18
Extensions.....	17

F

Flue gas route	3
----------------------	---

G

Grease.....	3
-------------	---

H

Horizontal roof duct, installing	14
Horizontal wall duct, installing	13
Horizontal wall/roof duct, preparing the installation.....	11

I

Ice formation.....	4
Installing extensions	25
Installing the 60/100 mm diameter flat-roof duct	20
Installing the 60/100 mm diameter pitched-roof duct	20
Installing the 80/125 mm diameter connection piece	11
Installing the 80/125 mm diameter flat-roof duct	23
Installing the 80/125 mm diameter pitched-roof duct	22
Installing the air clamps.....	34
Installing the sliding sleeve.....	24

L

Lightning	4
-----------------	---

M

M8 threaded rods	18
------------------------	----

O

Opening.....	3
Opening piece	14

Q

Qualification.....	3
--------------------	---

R

Regulations	5
Ridge tiles.....	21

S

Seal	3
Securing the telescopic extension.....	34
Shortening the air/flue gas pipe.....	12

T

Terminal	
Black	14
Tool	5

V

Variable terminal kit.....	16
----------------------------	----



0020209592_03 ■ 29.06.2016

supplier

Vaillant Ltd.

Nottingham Road ■ Belper ■ Derbyshire ■ DE56 1JT

Telephone 0330 100 3461

info@vaillant.co.uk ■ www.vaillant.co.uk

© These instructions, or parts thereof, are protected by copyright and may be reproduced or distributed only with the manufacturer's written consent.

We reserve the right to make technical changes.