

SM1 & SM2 Electro Mechanical Time Controls

The SM1 timeswitch will automatically switch your boiler ON and OFF once or twice a day, at whatever times you choose.

The SM2 central heating programmer will automatically switch your heating and hot water system ON and OFF once or twice a day, at whatever times you choose.

If you have a fully pumped and controlled system you will be able to have central heating without hot water and vice versa. You can choose a different mode for your heating to hot water.

A gravity-fed hot water system does not allow heating to be on without hot water.

You also have the option to obtain continuous ON or OFF operation.

TECHNICAL DATA

Type: SM1 24 Hour Timeswitch

SM2 24-Hour Programmer

Voltage: 230V AC +10% -15% 50 Hz

Rating: 2 (1) A 230V AC

Ambient Temp: 0 °C to 45 °C Operating

0 °C to 50 °C Storage

Wiring: Designed for fixed wiring only to comply with current I.E.E. regulations.

Maintenance: No user maintenance should be attempted.

Programming the SM1 & SM2

These Electro Mechanical Time Controls are simple to use central heating controllers which can be set to give the programme you want as described below.

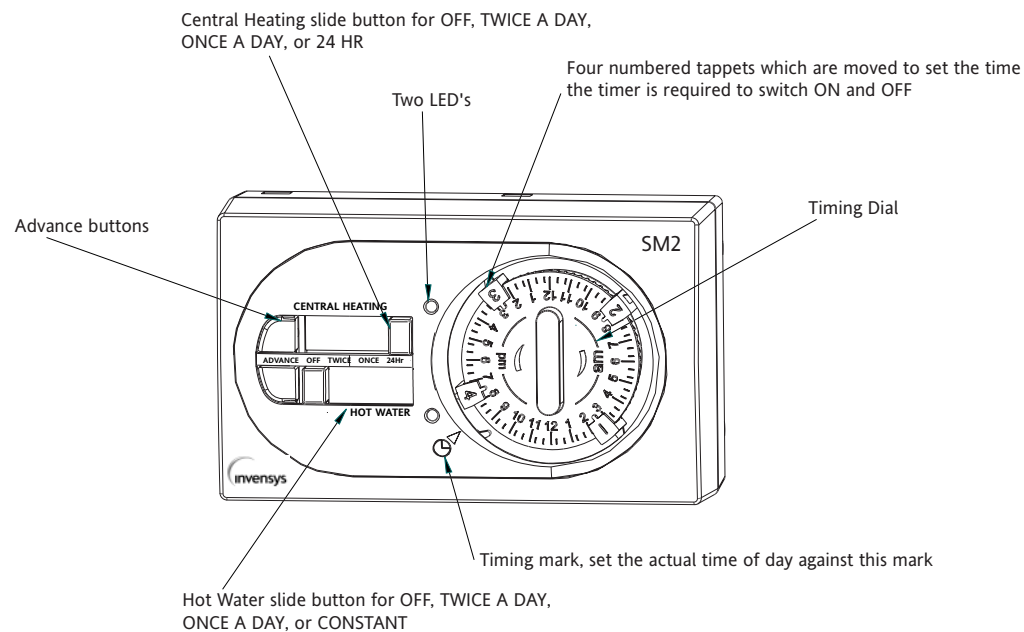

Using the switching tappets

The four tappets round the timing dial can be moved by pushing them in towards the dial and sliding them round to the desired switching time. When they are released they engage with the underside of the dial where they are securely held in position.

Twice a day setting

Push the hot water and/or central heating slide button to the "twice" position. Start with number 1 tappet which must be pushed and moved round the dial to the first On setting time required, release pressure to secure. Move number 2 tappet in the same way to the first chosen Off time. Move the number 3 tappet to your second On time and the number 4 tappet to the last Off time.

Once a day setting

Slide the hot water and/or central heating slide buttons to the "once" position. The programmer will now only operate the number 1 tappet for On, ignore the 2 and 3 tappets and operate the number 4 tappet for Off.

Note: it is important to use the correct tappets for the ON and OFF switchings otherwise the wrong programme will result.

Quick Reference Guide

The table below describes the operation of each of the four numbered switching tappets.

Switching Tappet No.	Timer Setting	
	Twice a Day Setting	Once a Day Setting
One	Heating/Hot Water on	Heating/Hot Water on
Two	Heating/Hot water off	Tappet not in use
Three	Heating/Hot Water on	Tappet not in use
Four	Heating/Hot Water off	Heating/Hot Water off

The LED's will light to indicate when the central heating and/or hot water is on.

Setting the timing dial

After the tappets have been set rotate the dial through 24 hours in the direction of the arrows printed on the dial, until the correct time is shown opposite the timing mark.

In setting the time of day, optimum accuracy is achieved by moving the dial clockwise close to the correct time, then turning gently anti-clockwise against the stop mechanism. If necessary make a fine adjustment by one further click clockwise and turn against the stop again. This replicates the action of the tappet against the cam as the dial rotates and enables closer setting of the time.

Note: rotating the dial the wrong way could result in damage to the Timer

Advance Facility

The SM1 Electro Mechanical Programmer is fitted with one advance button, the SM2 two advance buttons.

These buttons will advance the programme to the next switching event, i.e. if on it will go off, if off it will go on. For example, by pressing the appropriate advance button when the time control is in the middle of a heating cycle will make the time control move to a heating off position.

This facility enables you to override your programme temporarily. The programme will revert to normal timed operation at the next switching event. Thus if you are going out in the evening and don't want the rest of the evenings programme you can press the advance button to turn the heating or hot water on/off until the next programmed event. If both circuits are to be advanced each circuit should be treated as a separate function.

NB. If the programmer has been set to the Gravity hot water mode and the heating is off, pressing the heating advance will also bring on the hot water circuit.

Before Installation

Set the link on the back of the time control to P or G according to type of system.

For a pumped system remove the link and for a gravity system leave the link in place

P – Fully PUMPED and controlled system, allowing heating and hot water to be selected and function separately.

G – GRAVITY fed hot water system which does not permit heating to be on without hot water. It is possible to have hot water without heating.

Note: this link is not fitted on the SM1 timeswitch.

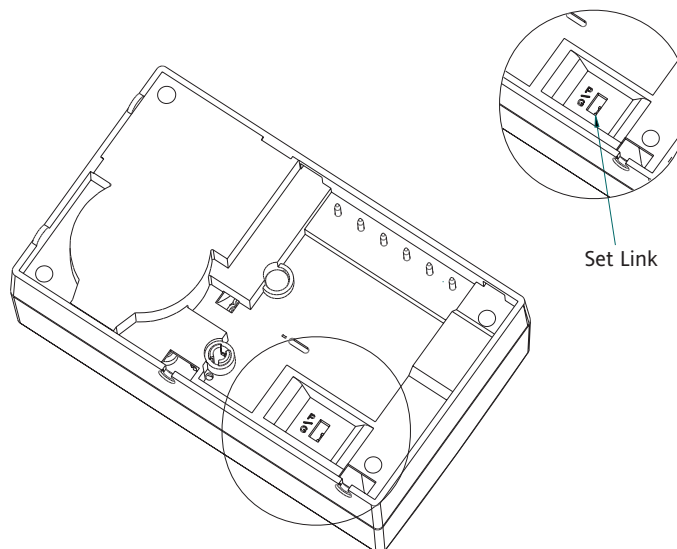

Installation

Make sure mains input has a 3 Amp fuse

Installation should be carried out by a qualified electrician or heating engineer and must conform to the I.E.E. Regulations for Electrical Equipment of Buildings and all other relevant standards.

In many cases the SM2 programmer will fit directly on to the existing wall-plate without any changes to existing wiring. The chart below shows which programmers can be directly replaced and the wiring detail of those that will need the wall-plate to be changed.

PROGRAMMER		Earth	Neutral	Live	HW Off	CH Off	HW On	CH On	Direct Replacement
Invensys	SM2		N	L	1	2	3	4	yes
British Gas	EMP2		N	L	1	2	3	4	yes
British Gas	UP1		N	L	1	2	3	4	yes
Drayton	Tempus 6 & 7 (New)		N	L	1	2	3	4	yes
Drayton	Tempus 3,4,6 & 7 (Old)		N	L	1	2	3	4	yes
Lifestyle	112, 241, 522 & 722		N	L	1	2	3	4	yes
Switchmaster	SM 400 & 600		N	L			3	1	no
Switchmaster	SM 805, 905, 9000, 9001		N	L	4	2	3	1	no
Barlo	EPR1		N	L	1	2	3	4	yes
Danfoss Randall	MK.18 Range CP, MP & FP	E	N	L	1	2	3	4	yes
Danfoss Randall	102,102E	E	5	3/6			1	2	no
Danfoss Randall	30-60	E	7	6			4	2	no
Danfoss Randall	40-33	E	7	1/6	5	3	4	2	no
Danfoss Randall	701	E	N	L/5/6			3	1	no
Danfoss Randall	702	E	N	L/5/6	4	2	3	1	no
Danfoss Randall	Set 2 & 5	E	N	L/2/5	3	6	1	4	no
Danfoss Randall	922, 972	E	N	L/2/5	1	1	3	6	no
Glowworm	Mastermind		N	L	1	2	3	4	yes
Grasslin Towerchron	DT72		N	L	1	2	3	4	no
Honeywel	ST699, 799		N	L/5/8	7	4	6	3	no
Honeywell	ST100A		N	L/3/6	7	4	8	5	no
Honeywell	ST1000	E	N	L	3	6	1	4	no
Honeywell	ST6200, 6300, 6400		N	L	1	2	3	4	no
Horstmann	Diadem	E	N	L/2/5	3	6	1	4	no
Horstmann	Tiara	E	N	L/2/5	3	6	1	4	no
Horstmann	525, 527	E	N	L/2/5	5	4	6		no
Horstmann	Centar Plus "C"		N	L	1	2	3	4	yes
Horstmann	Channel Plus "H"	E	N	L	3	6	1	4	no
Landis & Gyr (Staefa)	All RWB'		N	L	1	2	3	4	yes
Myson	Microtimer		N	L/5/8	7	4	6	3	no
Potterton	Miniminder		N	L	1	2	3	4	yes
Potterton	EP's		N	L/5	1	2	3	4	no
Sunvic	SP Range		N	L/3/6	1	4	2	5	no
Sunvic	Select		N	L	1	3	2	4	yes

Generally, when fitting the SM1 timeclock, although it will fit onto existing wall-plates, some wiring changes will be necessary. Please consult the chart below for guidance. The SM1 has Volt-Free terminals so you need to fit a link from L to Terminal 1 on the wall-plate if you want 230V output.

TIMESWITCHES

Make	Model	Earth	Neutral	Live	Common	On	Off	Spare	Action
Invensys	SM1		N	L	1	3	2	4	
British Gas	EMT2		N	L	1	3	2	4	
British Gas	UT1		N	L	1	3	2	4	
ACL-Drayton	Tempus 1 & 2(New)		N	L	1	3	2	4	A
Drayton	Tempus 1 & 2(Old)		N	L	1	2	3	4	B
ACL Lifestyle	111 & 711		N	L	1	3	2	4	A
ACL Switchmaster	SM 300, 980		N	L	4	1			C
Danfoss Randall	MK.18 Range TS	E	N	L	1	4	2	5/6	B
Danfoss Randall	Set 1 & 4	E	N	L	5	4	6		C
Danfoss Randall	103, 103E & 103E7	4	5	6	3	1		2	C
Danfoss Randall	911, 971	E	N	L	5	6	4	2	C
Grasslin Towerchron	DT71		N	L	3	4	2		C
Grasslin Towerchron	T2001, T2001Q	E	N	L		7			C
Honeywell	ST6100A, ST6100C		N	L	1	4	2		B
Honeywell	ST7000B			L		3	2		B
Horstmann	Centaur		N	L	4	3			C
Horstmann	Centaur Plus 'C'		N	L	2	4	3		B
Horstmann	Coronet	E	N	L	5	4	6		C
Horstmann	Emerald	E	N	L	3	4			C
Horstmann	517	E	N	L	5	4	6		C
Horstmann	Channel Plus 'H'	E	N	L	5	4	6		C
Landis & Gyr (Staefa)	RWB3		N	L		4	3		B
Landis & Gyr (Staefa)	All other RWB's		N	L	2	4	3		B
Potterton	EP Range		N	L	5	4	2		C
Sangamo	M6	E	4	6	3	1	2		C
Sunvic	SP Range		N	L	3	5	4	S	C
Sunvic	Select		N	L	1	3	2	4	A
Venner	Vennerette		N	L	Line	Load			C

LINK L – 1 FOR 230V OUTPUT. NO LINK REQUIRED FOR LOW VOLTAGE

- ACTIONS**
- A** - Fit onto existing wall-plate, no wiring changes required.
 - B** - Use existing wall-plate but move wires as indicated on the chart.
 - C** - Fit new wall-plate and wire as indicated on the chart.

Using an EXISTING WALL – PLATE

Switch off the mains. Loosen the securing screws on the old programmer and unplug it. Check that there is 59mm clearance to the right of the wall-plate and 28mm above.

These clearances are required for fitting purposes not operation.

Plug the control onto the wall-plate. Re-tighten securing screws. Check the fuse is 3A and switch on mains. Set timing and programme as detailed in Programming section.

Fitting NEW WALL – PLATE provided

Installation should be carried out by a qualified electrician or heating engineer and must comply with current I.E.E. Regulations for Electrical Equipment of Buildings and all other relevant standards.

Position the wall-plate with 59 mm clearance to its right, 28 mm above and access to the securing screws underneath (See Diagram). Ensure that the supporting surface will fully cover the back of the programmer. The ideal location is 1.4 m above floor level, accessible, reasonably lit and free from condensation or extremes of temperature.

Fix the wall-plate, terminals at the top, either direct to a flat wall using wall plugs and No. 6 x 1" wood screws or on a flush mounting single conduit box type UA1 (BS4662) using M3.5 x 14 screws. DO NOT use a surface mounting box.

Ensure the mains supply is switched off then make wiring connections as shown on this leaflet.

After wiring, plug in the control and tighten the securing screws. Check the fuse is 3A and switch on the mains. Set the time and programme as detailed in Programming section.

Always switch off the mains before removing the time control from the wall plate. NEVER FIT THE PROGRAMMER TO A LIVE WALL – PLATE.

Accessories

The DPT2 decoration plate can be used to cover damaged paint/wallpaper when replacing programmers of a larger size. This should be fitted to the wall prior to the new Wall-plate being fitted. The decorative plate is 180x160mm. Full instructions are supplied with the DPT2.

The SBT2 spacer box can be used if the existing programmer has been used as a wiring centre and you require more space behind the unit. There is sufficient space for a 10 way 3 Amp terminal block.

Dimensions & Wiring Diagrams

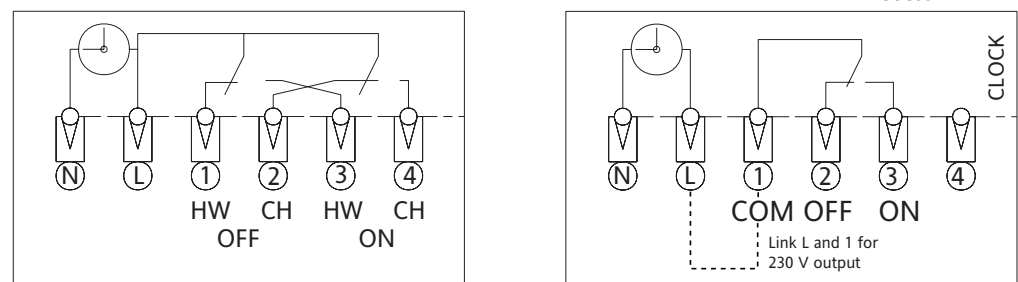
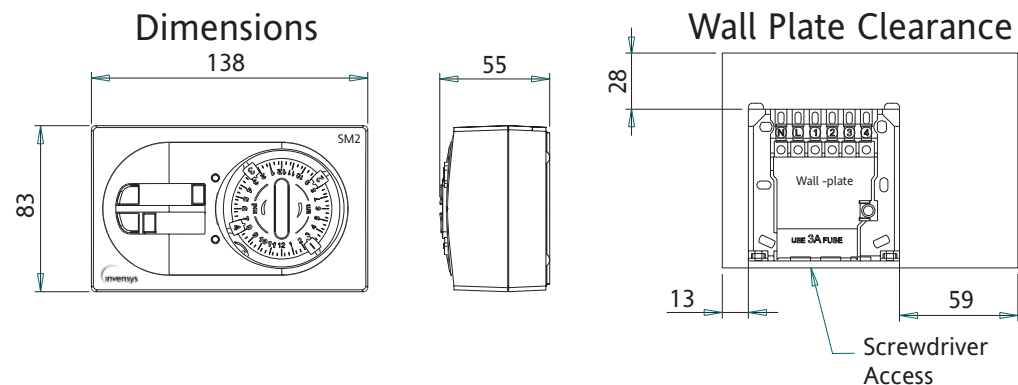

Dual Channel: SM2

Single Channel: SM1

These are typical wiring diagrams and can be used to help with wiring the SM2 into existing systems.

The arrowed numbers relate to terminals on the junction box. If the boiler has pump overrun, please consult the boiler manufacturers handbook.

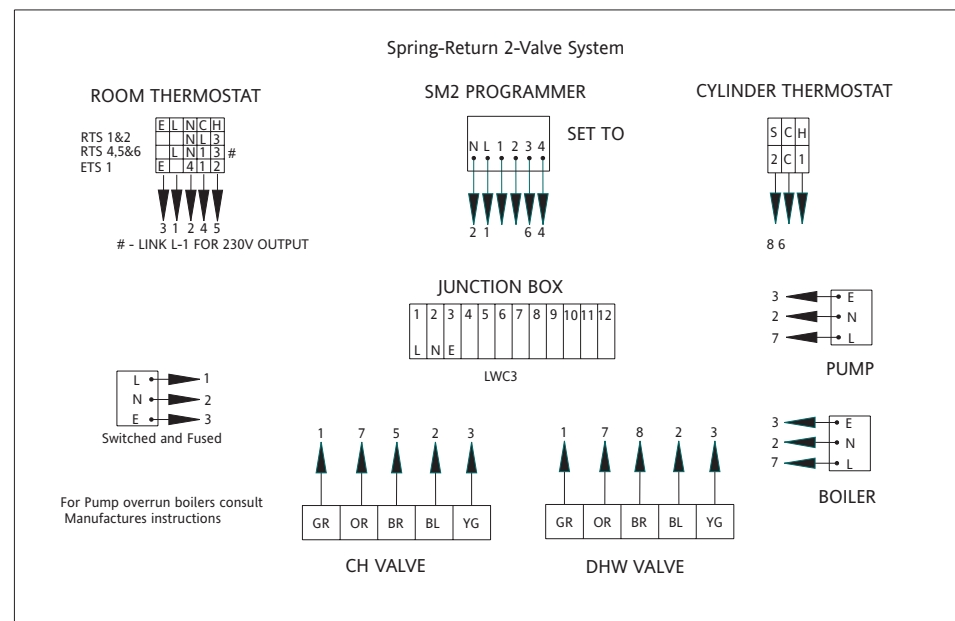
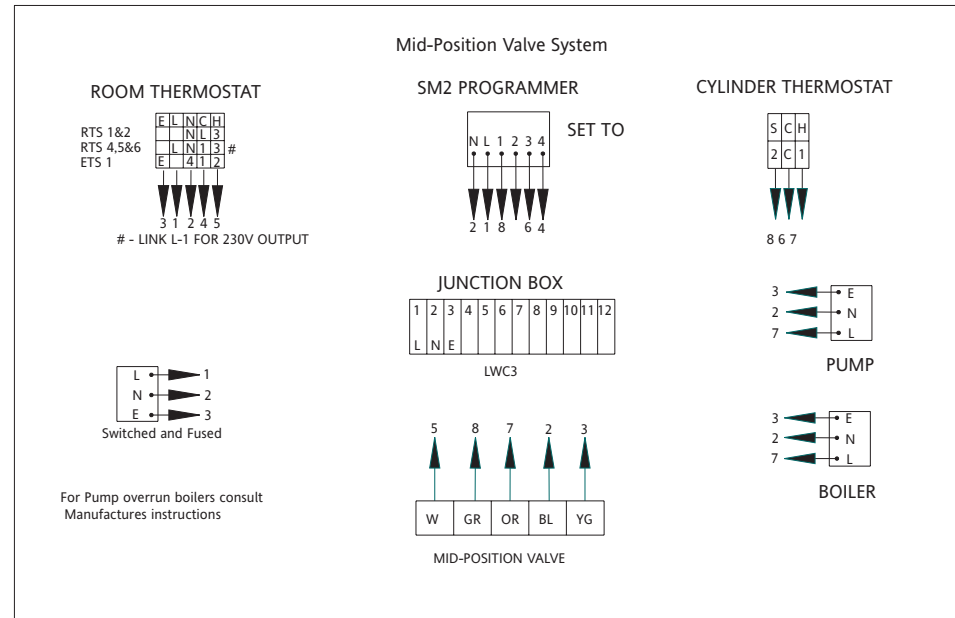
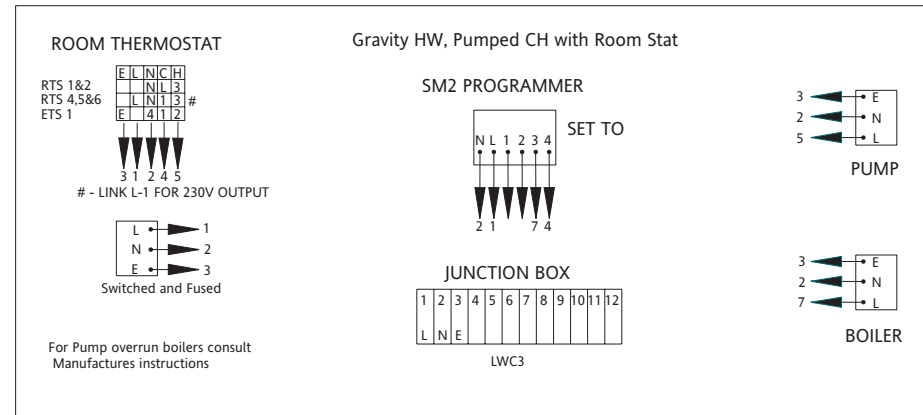

Key for Room and Cylinder thermostat

C = Common	N = Neutral
H = Call for Heat	E = Earth
S = Satisfied	L = Live

Wiring colour codes

GR = Grey	RD = Red
Y = Yellow	W = White
BK = Black	OR = Orange
BL = Blue	BR = Brown
Y/G = Yellow/Green	

CONFORMS TO THE ESSENTIAL REQUIREMENTS OF THE FOLLOWING DIRECTIVE

89/336/EEC – Electromagnetic compatibility 73/23/EEC - Low voltage directive



Invensys Climate Control Systems Europe
 Telephone: +44 (0) 845 130 5522
 Facsimile: +44 (0) 845 130 0622
 Technical Helpline: +44 (0) 845 130 7722
 Website: www.climate-eu.invensys.com
 Email: customerservices@invensys.com