

Product Catalogue

Issue 15

Drayton

by Schneider Electric



BRITISH BUILT TO LAST

YOUR AREA

Sales Manager by region

KEY

- 1 Scotland & Ireland
- 2 North East England
- 3 North West
- 4 Midlands & Wales
- 5 North East Midlands
- 6 South West
- 7 Oxfordshire, Home Counties
- 8 London, Essex & Suffolk
- 9 South East

1 Scotland & Ireland 07714 221886

AB	BT	DD	DG	EH	EIRE
FK	G	HS	IV	KA	KW
KY	ML	PA	PH	TD	ZE

2 North East England 07964 124609

BD	DH	DL	HD	HG	HU
HX	LS	NE	SR	TS	WF
YO					

3 North West 07815 967028

BB	BL	CA	CH	CW	
FY	IM	LLA	LL	M	
OL	PR	SK	WA	WN	

4 Midlands & Wales 07713 502140

B	CF	CV	DY	HR	LD
NP	SA	ST	SY	TF	WR
WS	WV				

5 North East Midlands 07976 294364

DE	DN	LE	LN	NG	NR
PE	S				

6 South West 07825 029021

BA	BH	BS	DT	EX	GL
GY	JE	PL	SN	SP	TA
TQ	TR				

7 Oxfordshire, Home Counties 07713 502154

GU	HP	LU	MK	NN	OX
PO	RG	SL	SO		

8 London, Essex & Suffolk 07713 502152

AL	CB	CM	CO	E	EC
EN	HA	IG	IP	N	NW
SG	SS	TW	UB	W	WC
WD					

9 South East 07713 502149

BN	BR	CR	CT	DA	KT
ME	RH	RM	SE	SM	SW
TN					

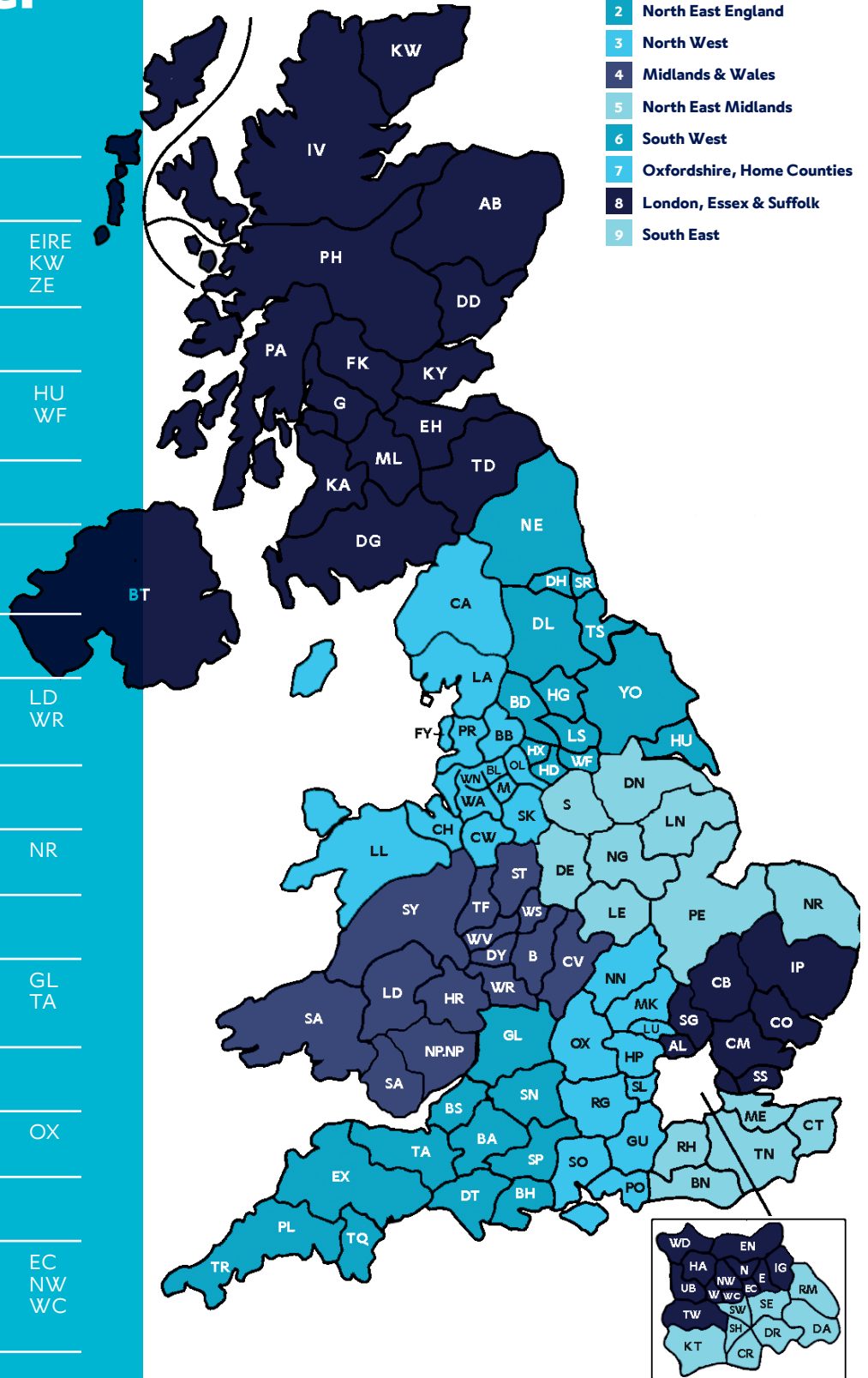

Sales: +44 (0) 333 6000 622

Technical: +44 (0) 333 7000 622

Fax: +44 (0) 333 1230 522

Email: customer.care@draytoncontrols.co.uk

www.draytoncontrols.co.uk

Contents

British Built to Last	P04
Save Over 50%	P05
New Exclusive Installer Club	P06
ErP	P07
New miGenie	P08
Technical Support	P10

ROOM THERMOSTATS WIRED & WIRELESS

RTS Room Thermostat Range	P12
Combi-Stat Room Thermostat	P13
Digistat ⁺ Room Thermostat	P14
Digistat ⁺ RF Wireless Room Thermostat	P15
Digistat ⁺ I Wired Room Thermostat	P16
Digistat ⁺ IRF Wireless Room Thermostat	P17
MiStat RF Wireless Room Thermostat	P18

PROGRAMMABLE ROOM THERMOSTATS WIRED & WIRELESS

Easy 2 & Easy 3 Electronic Clock Thermostats	P19
Digistat ⁺ 2 & Digistat ⁺ 3 Programmable Thermostats	P20
Digistat ⁺ 2RF & Digistat ⁺ 3RF	P21
MiStat RF Programmable Thermostat	P22

TIME CONTROLS

SMI & SM2 Electro-mechanical	
Timeswitch & Programmers	P23
Lifestyle LP & LPSi	P24-25
MiTime RF Wired Timeswitch & Programmers	P26-27
MiTime RF Packs	P28-29

CLIP-IN CONTROLS

Clip-in Controls for Worcester Boilers	P30-31
--	--------

MIGENIE

miGenie Internet Connected Controls	P32-33
-------------------------------------	--------

MOTORISED VALVES

Two Port & Mid Position Valves	P34
--------------------------------	-----

RADIATOR VALVES

Thermostatic Radiator Valves (TRVs)	P35
Thermostatic Radiator Valves RT4I4, RT3I3 and RT2I2	P36-37
TRV4 Thermostatic Radiator Valves	P38-39
Lockshield and Manual Valve	P40
EB Body Range and Adaptors	P41
Commercial Radiator Controls & Valves	P42-43
EB Flow Capacity	P44

AUTOMATIC BY-PASS VALVE

Automatic By-Pass Valve	P45
-------------------------	-----

CYLINDER & PIPE THERMOSTATS

HTS3 Cylinder Thermostat	P46
Digistat ⁺ C RF	P47
MiStat RF Wireless Cylinder Thermostat	P48
PTSI Pipe Thermostat	P49
Tapstat Cylinder Controls	P50

PACKS

Control Packs	P51-52
Combi Pack	P52
Frost Protection Pack	P52

UNDER FLOOR HEATING CONTROLS – HYDRONIC & ELECTRIC

Thermal Actuator	TS ⁺	P53
Thermostats & Connection Strips	RTR-E 6124	P54
	EV230 PL	P54
	EV-U 230 PL	P54

Instat 868-r Thermostat Range	Instat ⁺ 868-r	P55
	Instat 868-rl	P55

Instat 868-a Wireless	Instat 868-a4	P56
Connection Strip Range	Instat 868-a6	P56
	Instat 868-a8U	P56
	Instat 868-al	P56

MSV Manifold Hydronic Control Pack	P57
------------------------------------	-----

Electric Underfloor Heating Controls	Digistat ⁺ 3F	P58
	Digistat ⁺ 3L	P58

Programmable Thermostats	Easy 3L	P59
	Easy 3F	P59

Non Programmable Thermostat	FR-E 525 3I	P60
-----------------------------	-------------	-----

ACCESSORIES

Wiring Centres	P61
Drain Easy Kit	P62
Décor Plate & Spacer Box	P63

ADDITIONAL INFORMATION

Programmer Compatibility Guide	P64
Timeswitch Compatibility Guide	P65
Room Thermostat Compatibility Guide	P66
Principles of Intelligent Delayed Start	P67
Part L Building Regulations	P68
Twinzone Control Systems	P69-71
Biflo Control System	P72-74
Combi-Boiler System	P75
Two Port Zone Valve System	P76
The Genuine Article TRV4	P77
Commissioning Instructions	P78-79

BRITISH BUILT TO LAST

With over 60 years industry experience it's fair to say that Drayton know what they are doing when it comes to heating controls. All controls are engineered, developed and manufactured from the site in Plymouth, so when they say BRITISH BUILT TO LAST they mean it.



BRITISH BUILT TO LAST



BUILT TO MEET YOUR NEEDS

Drayton pride themselves on manufacturing quality products that you can rely on. With over 60 years of experience Drayton has built up an extensive portfolio of established products including thermostatic radiator valves, time controls, thermostats, underfloor heating, motorised valves...and everything in between. The latest addition to the comprehensive range includes innovative internet connected thermostat kits that can be controlled via an app from wherever you are.



BUILT ON EXPERIENCE

Drayton is part of Schneider Electric, a global technology group focused on helping customers make the most of their energy. As one of the world's top ten most sustainable companies, with over 170,000 employees in 100 countries, they have the infrastructure and experience to maximise potential and satisfy the evolving needs of customers.

BUILT ON QUALITY

Schneider Electric is classed as an "Industry Leader" by the Dow Jones Sustainability World and Europe. These high standards are evident in the Drayton factory in Plymouth where these certificates have been awarded:

- ISO9001 Quality Management System
- ISO14001 Environmental management System
- OHSAS18001 Occupational Health and Safety Management System

Drayton's commitment to recycling goes even beyond the requirements of the ISO14001 standard: since 2014 they have been operating with "Zero to Landfill" - none of their waste ends up in landfill sites; everything is reused, recycled or sold.

At Drayton we are continually improving and adding to our extensive range of products, so to keep up to date on our latest innovations visit www.draytoncontrols.co.uk



SAVE OVER 50% ON HEATING BILLS

HUGE POTENTIAL FOR ENERGY SAVING

By installing basic heating controls homeowners could save over 40% on heating. With more advanced controls the benefits can be a saving of over 50%. What's more the payback period is comparatively short making it even more appealing. Homeowners go to huge expense of upgrading windows and roof insulation, but if they knew how easily and cost effectively they could upgrade their controls and how much it would impact their fuel bills it would be a simple decision.

With a **50%** saving on your heating you could achieve a **25%** drop in your overall energy bills

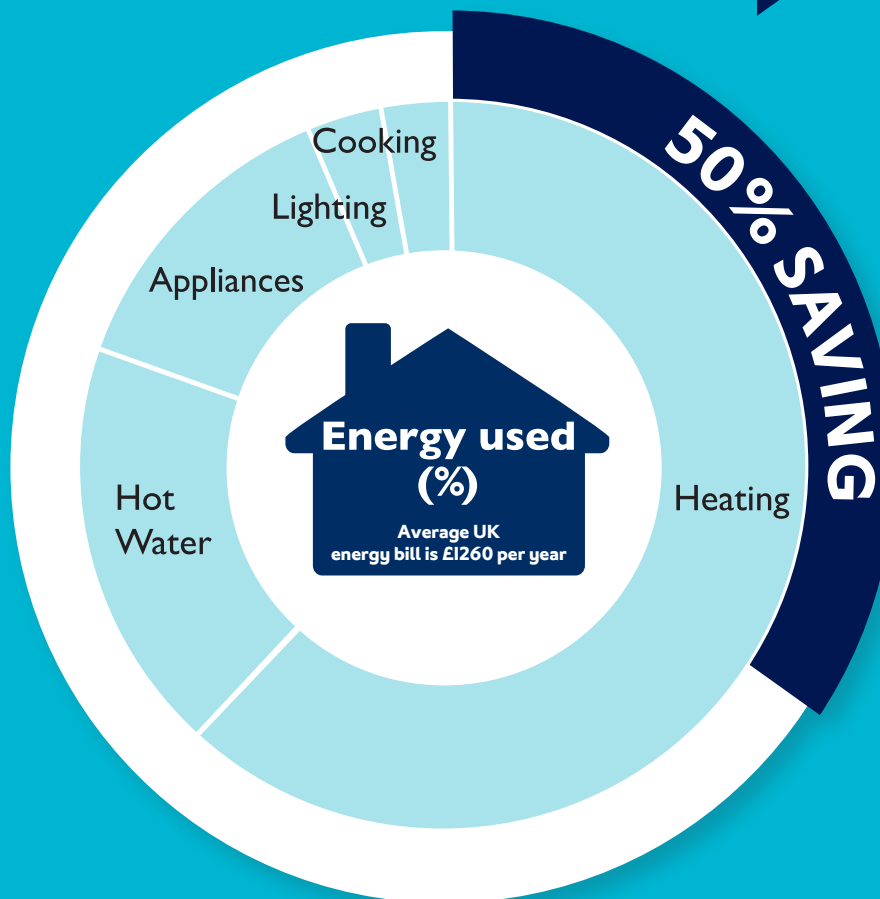

*BEAMA Heating Controls | www.beama.org.uk

YOUR CUSTOMERS NEED TO KNOW THE FACTS

- Over 80% of a home's energy consumption is used for heating and hot water (DECC 2013)
- Nearly 50% of UK homes do not have the minimum standard for heating controls (DECC 2014)
 - Installing basic heating controls can save 40% on heating bills (BEAMA 2013)
 - Installing more advanced controls can save over 50% on heating bills (BEAMA 2014)
- Install a room thermostat, TRVs and a time control and savings of over £400 per year can be achieved (BEAMA 2014)

NEW

EXCLUSIVE INSTALLER CLUB

The 9° Network is a new professional installer club designed to reward loyalty with exclusivity. The scheme is open to experienced professional installers and provides a wealth of benefits including:

- **Extended product guarantees – 5 years**
- **Professional installer status/membership card**
- **Exclusive training opportunities**
- **Priority technical support contact**
- **Professional installer van sticker and T-shirt**
- **New product previews and trialling**
- **Access to exclusive web portal for exclusive content including logo, images and training**

**PLUS
MUCH MORE!**

Drayton



Network

**PROFESSIONAL
INSTALLER**

**JOIN
TODAY**

Join the 9° Network

If you would like to be part of this new and exclusive network simply visit www.draytoncontrols.co.uk/9degrees and complete the registration form.

We look forward to welcoming you to the club*

*Terms and conditions apply

ErP

WHAT YOU NEED TO KNOW



The new ErP regulations came into force in September 2015, defining the minimum energy performance criteria for a number of household products, including boilers, combination boilers, water heaters and other heating appliances up to 400kW.

ErP stands for 'Energy-related Products', and the ErP directive is a new regulation set by the European Union. The regulations have been put in place in order to improve the efficiency of heating and hot water products.

The aim is to inform and educate homeowners about the efficiency of their appliances, by a placing a clearly displayed energy label on the product. Manufacturers must adhere to efficiency and emissions limits, which will be laid out in the ErP performance criteria.

ENERGY LABELLING

As part of this, Europe-wide energy labelling requirements will be introduced for boilers, combination boilers, water heaters and other heating products in both the domestic and light commercial sectors up to 70kW.

HOW WILL THIS AFFECT THE INSTALLER?

It will be the installer's responsibility to ensure any heating appliance that they fit has the correct energy label, which will be supplied with the item when it is purchased.

The installer will need to provide a package label too, when combining a heating appliance with another product such as a thermostat.

The package label must include the combined energy efficiency rating of the whole system, as opposed to just the individual ratings of each component.

If the merchant is the one who puts together a package of products, they will be responsible for creating the package label. However, if the installer buys a suite of products separately, the onus is on them to produce the package label.

PRODUCING A PACKAGE LABEL

To calculate the overall package efficiency, the installer must record each product on a document known as a fiche.

This document allows installers to clearly show their energy efficiency calculations, and to mark the package label with an arrow corresponding to the efficiency class.

It is then the installer's responsibility to alert the customer to the label and explain the calculations if required.

The package scale is defined as below.

A+++	≥ 150%
A++	≥ 125%
A+	≥ 98%
A	≥ 90%
B	≥ 82%
C	≥ 75%
D	≥ 36%
E	≥ 34%
F	≥ 30%
G	≥ 30%

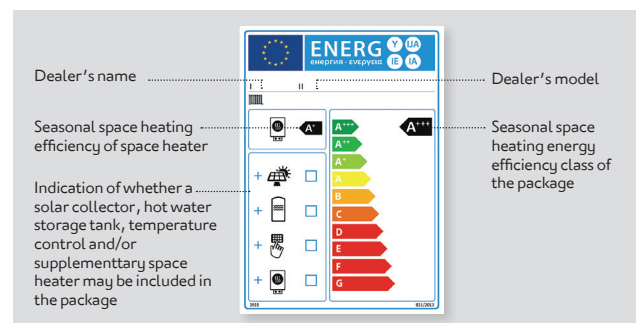

The installer is responsible for providing the package label to the customer.

HEATING CONTROLS AND PACKAGES

Installers need to recognise that heating controls have a big effect on boiler efficiency, and so this can affect the labelling requirements for packages.

An example of a simple package is a boiler and a thermostat, which is a very common installation in the UK. When creating the package fiche, the installer needs to complete the following calculation:

- Insert the energy efficiency % of the boiler, eg 88%
- Add the Temperature Control Class, eg 2%
- Add them both together = 90%
- 90% gives you an A rating for the package

TEMPERATURE CONTROL CLASS

There are eight classes (1 to 8) with corresponding percentages that can be inserted in the package fiche. Drayton thermostats are mainly Class IV which means 2% is added in the fiche.



Drayton's role as a heating control manufacturer is to advise the installer of the class of each of its thermostats. The temperature class is found in the product instructions (in the box), in the catalogues and datasheets and on the website.

miGenie®

NEW FOR 2015 INTERNET CONNECTED THERMOSTAT

The latest addition to the Drayton product family is miGenie, the fantastic new range of internet connected heating products that that will add a touch of magic to your life.

miGenie has all the benefits of the traditional controls you know and love, but with the added benefit of being able to be controlled via an easy to use mobile app, as well as the familiar interface.



SMART MADE SIMPLE

As the rise of smart technology becomes common place, more and more consumers are requesting heating controls that can be controlled via mobile devices. If you are asked for internet connected controls miGenie is the best option. But why?

miGenie is the perfect combination of familiarity and modern technology. The standard backplate means you can upgrade in minutes; the pre-bound two-way wireless connection means units are ready to go straight out of the box; and the signal strength indicator ensures correct positioning first time. All that's left to do is plug the internet gateway into the router and the mains and you're done - installation can be done and dusted in just 10 minutes.

OPEN SESAME!

Available for IOS and Android the miGenie app opens up a whole new world of convenience, once the app is downloaded, heating and hot water can be controlled from a phone, tablet or Apple Watch, so wherever you are, you can be in complete control. You no longer need to be a slave to your heating schedule...you can be its master.



Benefit from familiar products with a modern twist. See pages 32-33 for product details



BRITISH BUILT TO LAST

NEW

Smart heating in 3 clicks

[Time for a cuppa then]



miGenie[®]
Smart made simple

Internet connected heating controls

www.mi-genie.co.uk
0333 6000 622

Easy install in just 10 minutes



Drayton
by Schneider Electric



Drayton

by Schneider Electric

Worried about WIRING?

Stumped by Zoning?

BAFFLED by regulations?

Need guidance on installation?

DRAYTON TECHNICAL SUPPORT TEAM ARE HERE TO HELP

Our team of technical experts are on hand with advice and support.

Whether a programming problem, an installation issue or a general concern, they will be able to answer your questions and talk you through any queries.

CALL OUR DEDICATED SUPPORT LINE



0333 7000 622

Open Monday to Friday 8.00 - 6.00

EMAIL US WITH ANY QUERIES



customer.care@draytoncontrols.co.uk

SEND US A TWEET



@DraytonHeating

PRODUCT RANGE

- THERMOSTATS
- PROGRAMMERS
- TIME CONTROLS
- TRVS
- PACKS
- UNDERFLOOR HEATING
- ACCESSORIES

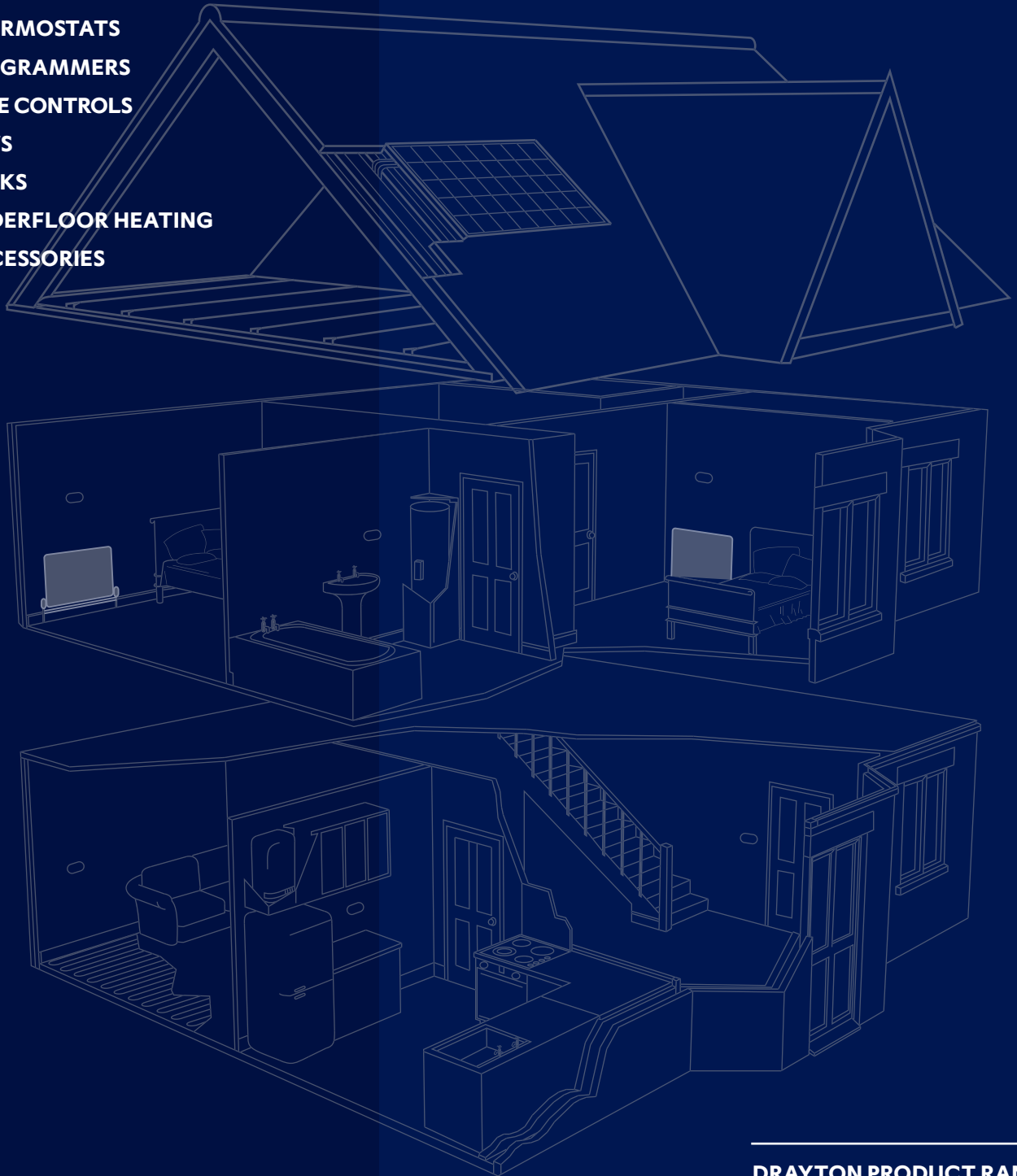

DRAYTON PRODUCT RANGE

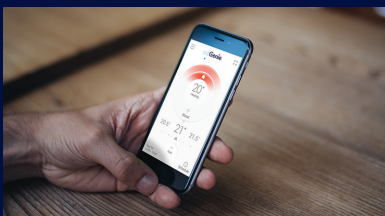

RTS

Room Thermostat Range

The RTS range of thermostats utilise electronic sensing to provide accurate temperature control. Five models are available to suit all domestic applications including frost protection and combi boilers.

MODELS:

- RTS1: Standard model
- RTS2: With LED 'ON' indicator
- RTS3: Frost thermostat
- RTS4: Volt-free contacts (Suitable for combi boilers)
- RTS9: Volt-free heating/cooling change over switch with call for heat LED indicator
- RTS10: Volt-free heating/cooling change over switch with call for heat LED indicator (Min-Max)

FLEXIBLE FEATURES:

- Range limiting stops
- Set point locking
- Surface or conduit box mounting
- Double insulated

Wiring Diagram

Fig.1 RTS1, RTS2, RTS3

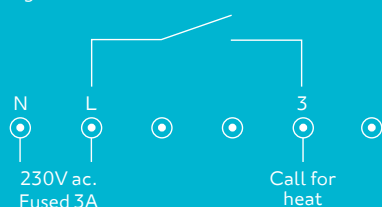
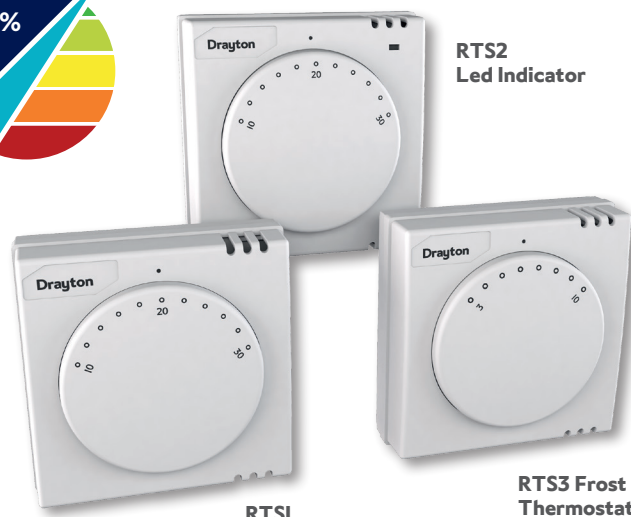
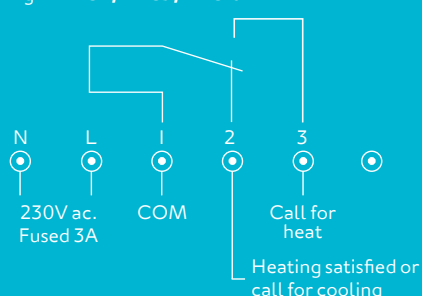

Fig.2 RTS4, RTS9, RTS10



GETTING TECHNICAL

Model:	RTS
Power Supply:	230V ac 50Hz fused 3A
230V ac 50Hz fused 3A	Double insulated (no earth required)
Switch Rating:	2(l)A 230V a.c.
Switch Type: RTS1, 2 & 3: RTS4, 9 & 10:	S.P.S.T S.P.D.T. Volt-free
Wiring:	Designed for fixed wiring only, to comply with current IET wiring regulations (BS7671).
Mounting:	Suitable for surface or conduit box mounting
Ambient Temperature:	Operating 0°C to 40°C / Storage -20°C to 55°C
Ambient humidity (non condensing):	Operating 25% to 90% / Storage 25% to 90%
Temperature Range:	
RTS1, 2, 4 & 9:	10 to 30°C
RTS10:	14 to 30°C
RTS3 (Frost):	3 to 10°C
Control Accuracy:	
RTS1, 2, 4, 9 & 10:	<0.6°C at 4°/hour
RTS3:	1°C typical
Ball Pressure Test:	75°C
Pollution Degree:	2
Energy Class:	IV = 2% (Acc. EU 811/2013, 812/2013, 813/2013, 814/2013)
Relevant EC Directives:	2006/95/EC Low Voltage Directive 2004/108/EC Electromagnetic Compatibility Directive 2011/65/EU RoHS Directive
Applied Standards:	EN60730-1; EN60730-2-9

RTS ROOM THERMOSTATS

Product	Part No.
RTS1 SPST Contacts	24001
RTS2 SPST With LED Indicator	24002
RTS3 SPST Frost Thermostat	24003
RTS4 SPDT Volt Free contacts	24004
RTS9 SPDT Volt Free +LED	24030
RTS10 SPDT Volt Free +LED (Min 14°C)	24031
RTS Pattness	24022

CombiStat

Room Thermostat

Using a simple, traditional dial, the Combi-Stat provides accurate temperature control, suitable for all 2 or 3 wire combination / conventional boilers (with current up to 6A).

APPLICATION:

Suitable for 2 or 3 wire combination / conventional boilers
Ideal for 2 or 3 wire retro-fit applications

FLEXIBLE FEATURES:

- Range limiting stops
- Set point locking
- Surface or conduit box mounting
- Double insulated

COMBISTAT

Product	Part No.
RTS8 CombiStat	24028



GETTING TECHNICAL

Model:	Combi-Stat
Power Supply:	24-230V a.c./d.c. 50Hz fused 3A Double insulated (no earth required)
Switch Rating:	6(2)A 230V a.c./d.c.
Switch Type:	S.P.S.T
Wiring:	Designed for fixed wiring only, to comply with current IET wiring regulations (BS7671).
Mounting:	Suitable for surface or conduit box mounting
Ambient Temperature:	Operating 0°C to 40°C / Storage -20°C to 55°C
Ambient humidity (non condensing):	Operating 25% to 90% / Storage 25% to 90%
Temperature Range:	10 to 30°C
Control Accuracy:	1°C typical
Ball Pressure Test:	75°C
Pollution Degree:	2
Energy Class:	I = 1% (Acc. EU 811/2013, 812/2013, 813/2013, 814/2013)
Relevant EC Directives:	2006/95/EC Low Voltage Directive 2004/108/EC Electromagnetic Compatibility Directive 2011/65/EU RoHS Directive
Applied Standards:	EN60730-1; EN60730-2-9

WIRING:

2 wire connection. No neutral. **Load = 0.1A to 0.6A.**

Suitable for most wet CH systems.

Note: Use this connection for gas CH systems, where there is no neutral wire, and follow set-up procedure. If current reading above 0.6 amps, wire as 2 wire connection opposite. 2 wire connection no Neutral.

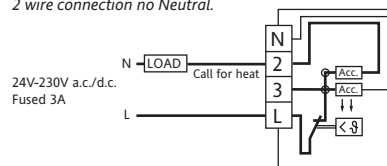

3 wire connection. **Max load = 2A.**

Suitable for most wet CH systems.

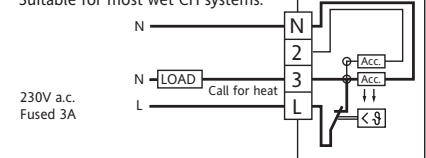

2 wire connection. No neutral.

Load = 0.6A to 6A.

Typically for higher loads (i.e. electric heating)

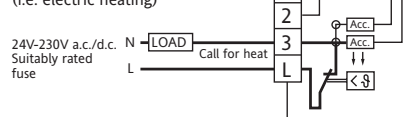

Digistat⁺

Wired Room Thermostat

Drayton's stylish Digistat+ with tactile, audible & visual feedback. Featuring a familiar dial control with a digital display to show that the temperature has been set accurately every time.

The product can be configured with a minimum temperature setting to protect the vulnerable.

FEATURES:

- Conventional dial adjustment
- TPI Control
- Tactile dial
- 1°C setting steps
- Tactile & audible feedback via click of the dial
- Visual feedback via digital display
- Set-back feature
- Min/Max temperature setting
- Battery powered
- Digital display situated above dial for ease of reading

Wiring:

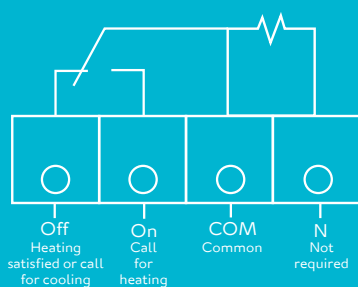

FOR FIXED WIRING ONLY

DIGISTAT⁺

Product	Part No.
Digistat ⁺	30002



GETTING TECHNICAL

Model	Digistat ⁺
Power Supply:	2 X 1.5V IEC LR6(AA) alkaline batteries
Switch Type & Rating:	SPDT 2(I)A I2-230V a.c./d.c. Volt free
Wiring:	Designed for fixed wiring only, to comply with current IET wiring regulations (BS7671).
Mounting:	Suitable for surface or conduit box mounting
Battery life:	2 years typical
Ambient Temperature:	Operating 0°C to 40°C / Storage -20°C to 55°C
Ambient humidity (non condensing):	Operating 25% to 90% / Storage 25% to 90%
Temperature Range:	5 to 30°C
Temperature resolution:	1.0°C
Control Accuracy:	+ 0.5K @ 20°C
Control Algorithm:	TPI, TP
Ball Pressure Test:	75°C
Pollution Degree:	2
Energy Class:	IV = 2% (Acc. EU 811/2013, 812/2013, 813/2013, 814/2013)
Relevant EC Directives:	2006/95/EC Low Voltage Directive 2004/108/EC Electromagnetic Compatibility Directive 2013/56/EU Battery Directive 2011/65/EU RoHS Directive
Applied Standards:	EN60730-1; EN60730-2-9

Digistat⁺RF

Wireless Room Thermostat

The Digistat+RF includes all the features of the Digistat+ with the added benefit of wireless connectivity.

Wireless thermostats are quick and easy to install saving you, and your customer, time and hassle.

FEATURES:

- Conventional dial adjustment
- TPI Control
- Tactile dial
- 1°C setting steps
- Tactile and audible feedback via click of the dial.
- Visual feedback via digital display
- Set-back feature
- Min/Max temperature setting
- Battery powered
- Digital display situated above dial for ease of reading

Wiring - SCR Receiver:

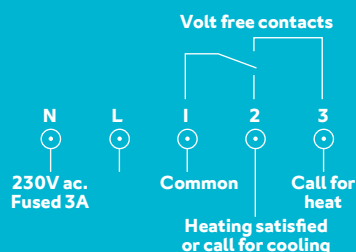

DIGISTAT⁺ RF

Product	Part No.
Digistat+RF room thermostat & SCR	RF601
Digistat+RF transmitter spare	31003
Digistat+SCR receiver spare	22149

Drayton

by Schneider Electric



GETTING TECHNICAL

Model	Digistat ⁺ RF	SCR (receiver)
Power supply:	2 X 1.5V IEC LR6(AA) alkaline batteries	230V a.c. 50Hz
Switch type and rating:	N/A	SPDT (voltage free) 2(1)A 230V a.c. or 24V a.c./d.c
Wiring:	Designed for fixed wiring only, to comply with current IET wiring regulations (BS7671).	
Mounting:	Suitable for surface or conduit box mounting	Industry standard wall plate
Battery life:	2 years typical	N/A
Ambient temperature:	Operating 0°C to 40°C / Storage - 20°C to 55°C	
Ambient humidit (non condensing):	Operating 25% to 90% / Storage 15% to 95%	
Temperature range:	5°C to 30°C	
Control Accuracy:	+ 0.5K @ 20°C	
Control Alorhythm:	TPI, TP	
Temperature resolution:	1.0°C	
Ball pressure test:	75°C	
Pollution situation:	Degree 2	
Protection level:	IP30	
Pollution Class:	2	
Software Class:	A	
Radio frequency:	433 MHz	
Radio Signal Range:	30m typically. The range may be affected by the composition / density and number of walls between the thermostat and receiver.	
Energy Class:	IV = 2% (Acc. EU 811/2013, 812/2013, 813/2013, 814/2013)	
Relevant EC directives:	2006/95/EC Low Voltage Directive 2004/108/EC Electromagnetic Compatibility Directive 1999/5/EC R&TTE Directive 2013/56/EU Battery Directive 2011/65/EU RoHS Directive	
Applied standards:	EN60730-1; EN60730-2-9 EN 300 220-2; EN 301 489-3	

Digistat⁺I

Wired Room Thermostat

Drayton's stylish Digistat⁺I. Featuring large buttons and an easy to read large and clear digital display to show that the temperature has been set accurately.

The product can be configured with a minimum temperature setting to protect the vulnerable.

FEATURES:

- Easy to use - only 4 buttons
- TPI Control
- Visual feedback via digital display
- Comfort feature
- Set-back feature
- Min/Max temperature setting
- Battery powered
- Part L compliant (Part J in Scotland)



Wiring:

Combi Boiler

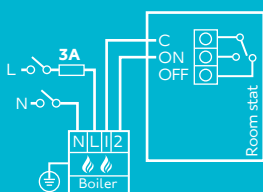

Basic Boiler with Zone Valve

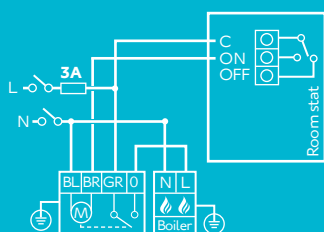

Basic Boiler

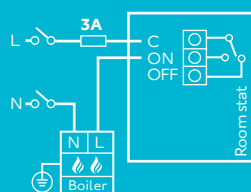

DIGISTAT⁺I

Product	Part No.
Digistat ⁺ I	22192

GETTING TECHNICAL

Model	Digistat ⁺ I
Power Supply:	2 X 1.5V IEC LR6(AA) alkaline batteries
Switch Type & Rating:	SPDT I6(2)A 230V a.c. Volt free
Min. recommended current:	10mA@24V a.c. (inductive)
Wiring:	Designed for fixed wiring only, to comply with current IET wiring regulations (BS7671).
Mounting:	Suitable for surface or conduit box mounting
Battery life:	2 years typical
Ambient Temperature:	Operating 0°C to 40°C / Storage -20°C to 55°C
Ambient humidity (non condensing):	Operating 25% to 90% / Storage 25% to 90%
Temperature Range:	5 to 30°C
Temperature resolution:	0.5°C
Control Accuracy:	+ 0.5K @ 20°C
Control Algorithm:	TPI, TP
Ball Pressure Test:	75°C
Pollution Degree:	2
Energy Class:	IV = 2% (Acc. EU 811/2013, 812/2013, 813/2013, 814/2013)
Relevant EC Directives:	2006/95/EC Low Voltage Directive 2004/108/EC Electromagnetic Compatibility Directive 2013/56/EU Battery Directive 2011/65/EU RoHS Directive
Applied Standards:	EN60730-1; EN60730-2-9

Digistat⁺IRF

Wireless Room Thermostat

Digistat⁺IRF offers the same 'easy to use' features of Digistat⁺I with the additional benefit of wireless connectivity making it even easier to install.

FEATURES:

- Easy to use - only 4 buttons
- TPI Control
- Visual feedback via digital display
- Comfort feature
- Set-back feature
- Min/Max temperature setting
- Battery powered
- Part L compliant (Part J in Scotland)

BENEFITS OF A COST EFFECTIVE WIRELESS SYSTEM:

The Digistat⁺ Wireless System provides a cost effective solution to the problems encountered during the installation of a standard wired room thermostat.

CONSIDER THE BENEFITS OF A WIRELESS THERMOSTAT:

- No carpets and floor-boards to lift
- No damage to wall coverings
- No unsightly surface wiring
- Positioning no longer restricted to areas accessible by cable runs
- No brick or plaster work to chase out
- No damage to fabrics and furnishings in the process

DIGISTAT⁺IRF

Product	Part No.
Digistat+IRF room thermostat & SCR	RF710
Digistat+IRF transmitter spare	22190
Digistat+IRF SCR Receiver Spare	22149

SCR Wiring:

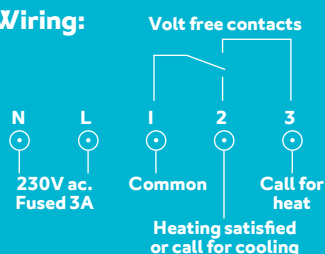

Drayton

by Schneider Electric



GETTING TECHNICAL

Model	Digistat ⁺ IRF	SCR (receiver)
Power supply:	2 X 1.5V IEC LR6(AA) alkaline batteries	230V a.c. 50Hz
Switch type and rating:	N/A	SPDT (voltage free) 2(1)A 230V a.c. or 24V a.c./d.c
Wiring:	Designed for fixed wiring only, to comply with current IET wiring regulations (BS7671).	
Mounting:	Suitable for surface or conduit box mounting	Industry standard wall plate
Battery life:	2 years typical	N/A
Ambient temperature:	Operating 0°C to 40°C / Storage - 20°C to 55°C	
Ambient humidit (non condensing):	Operating 25% to 90% / Storage 15% to 95%	
Temperature range:	5°C to 30°C	
Control Accuracy:	+ 0.5K @ 20°C	
Control Alogithm:	TPI, TP	
Temperature resolution:	0.5°C	
Ball pressure test:	75°C	
Pollution situation:	Degree 2	
Protection level:	IP30	
Pollution Class:	2	
Software Class:	A	
Radio frequency:	433 MHz	
Radio Signal Range:	30m typically. The range may be affected by the composition / density and number of walls between the thermostat and receiver.	
Energy Class:	IV = 2% (Acc. EU 811/2013, 812/2013, 813/2013, 814/2013)	
Relevant EC directives:	2006/95/EC Low Voltage Directive 2004/108/EC Electromagnetic Compatibility Directive 1999/5/EC R&TTE Directive 2013/56/EU Battery Directive 2011/65/EU RoHS Directive	
Applied standards:	EN60730-1; EN60730-2-9 EN 300 220-2; EN 301 489-3	

MiStat RF

Wireless Room Thermostat

The Drayton MiStat RF room thermostat features a new design that allows it to be wall mounted or freestanding. It's wireless and comes pre-bound with a signal strength indicator making it easy to install and reliable.



FEATURES:

- Pre-bound, two-way wireless connection
- Signal strength indication ensuring correct positioning
- TPI, TP & On/Off algorithms
- Can be freestanding or wall mounted
- Memory saver - settings never need resetting in the event of power loss
- 868 MHz frequency for reliable connection
- Universally recognised buttons and symbols
- Default comfort/set-back temperatures can be pre-set
- Timer override feature (boost)
- Quick and easy installation
- Just one button to change between comfort and set-back temperatures
- Access protection (screen lock)

MiSTAT RF

Product	Part No.
MiStat Room Thermostat + Receiver	MNIIOR9K0900
MiStat Room Thermostat	MNIIOR0S0900
MiStat Receiver	MRIIIMIS0900

Wiring - SCR Receiver:

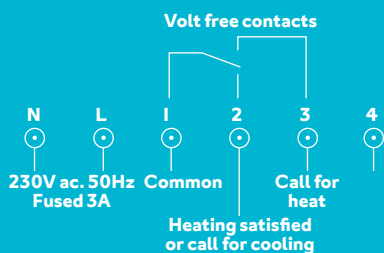

MiStat room thermostats are also available as part of MiTime RF Packs offering complete control solutions. See page 28 for details

GETTING TECHNICAL

Product type	MiStat N	MiStatR (receiver)
Power supply	2 x AA Size, 1.5V alkaline batteries	230V a.c. 50Hz
Switch type & rating:	N/A	SPDT (voltage free) 2(I)A 230V a.c.
Wiring:	No wiring required	Designed for fixed wiring only, to comply with current IET wiring regulations (BS7671).
Mounting:	Suitable for surface mounting with wall-clip or freestanding with table stand	Industry standard wall plate
Battery life:	2 years typical	N/A
Ambient temperature:	Operating 0°C to 45°C / Storage - 20°C to 55°C	
Ambient humidity (non condensing):	Operating 25% to 90% / Storage 15% to 95%	
Temperature range:	5°C to 30°C	
Control Accuracy:	+ 0.5K @ 20°C	
Control Algorithm:	TPI, TP, On/Off	
Timing resolution:	1 minute	
Temperature resolution:	0.5°C	
Ball pressure test:	75°C	
Pollution situation:	Degree 2	
Protection level:	IP30	
Pollution Class:	2	
Software Class:	A	
Radio frequency:	868.3 MHz Bi Directional	
Radio Signal Range:	30m typically. The range may be affected by the composition / density and number of walls between the thermostat and receiver.	
Energy Class:	IV = 2% (Acc. EU 811/2013, 812/2013, 813/2013, 814/2013)	
Relevant EC directives:	2006/95/EC Low Voltage Directive 2004/108/EC Electromagnetic Compatibility Directive 1999/5/EC R&TTE Directive 2013/56/EU Battery Directive 2011/65/EU RoHS Directive	
Applied standards:	EN60730-1; EN60730-2-7; EN60730-2-9 EN 300 220-2; EN 301 489-3	

Easy 2 & Easy 3 Electronic Clock Thermostats

Drayton presents a range of simple-to-use programmable controls with traditional analogue clock face.

FEATURES:

- Separate dials for comfort and set-back temperatures
- 5 operational modes via setting dial for Comfort / Set-back / Automatic / Frost protection / Off
- Hinged cover to give neat appearance

EASY ELECTRONIC CLOCKS

Product	Part No.
Easy 2	515 2701 91 III
Easy 3	517 2701 51 III

Easy 2 wiring:

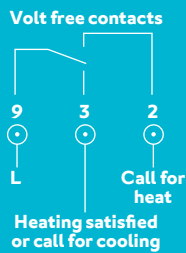

Easy 3 wiring:

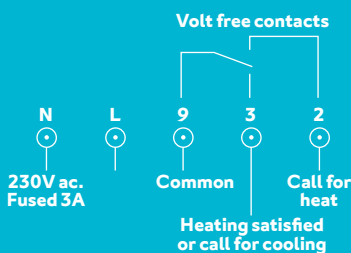

Drayton

by Schneider Electric



GETTING TECHNICAL

Model	Easy 2	Easy 3
	Battery	Mains
Temperature Setting Room Temperature:	5 to 30°C	5 to 30°C
Set-Back Temperature	5 to 30°C (setting under cover)	5 to 30°C (setting under cover)
Frost Protection	~ 5°C (fixed)	~ 5°C (fixed)
Contact (Relay)	1 change-over, voltage free	1 change-over, voltage free
Operating Voltage	1.5V Battery (service life~2 years)	230 V a.c.
Switching Current/ Voltage	10 mA to 10 A $\cos \varphi = 1$ max. 4A $\cos \varphi = 0.6$	10 mA to 16 A * $\cos \varphi = 1$ max. 4A $\cos \varphi = 0.6$
Hysteresis	~ 0,5 K	~ 0,5 K; *
LED Indicators		Call for heat / Set-back
Power Reserve		~ 100 h
Protection Class of Housing	IP 30 / insulated	IP 30 / insulated
Temperature Sensor	NTC Internal	NTC Internal (remote sensor F 193 720 or F 190 021 optional, max 50m)
Dimensions	160 x 80 x 36 mm	160 x 80 x 36mm

* at 16 A and operation without remote sensor: hysteresis ~ 2,5 K

Digistat

+2/+3

Wired Programmable Room Thermostats

Drayton brings you a range of Digistat⁺ programmable room thermostats. They are easy to install, easy to use and offer a supreme level of heating control and comfort. The range comes with a wealth of big pluses for both installers and users.

FEATURES:

- Easy to use
- TPI Control
- Easy to programme using only 4 buttons
- Memory-saver programme and clock never needs resetting in the event of power loss
- Automatic summer, winter time change
- Pre-set clock
- 3 built-in standard pre-defined programmes
- A choice of 2, 4 or 6 time/temperature events/day (user selectable)
- Easy to read large LCD display (showing actual time and room temperature)
- Easy temperature override
- Holiday mode
- Manual mode
- Temperature limit locks (high & low)
- Intelligent Delayed Start option (see page 65)
- 12/24 hour clock choice
- Contemporary design
- Part L compliant (Part J in Scotland)
- Suitable for combi boilers, electric heat, hydronic under-floor and zoning (Digistat⁺2 & Digistat⁺3)
- No wires needed between room unit & receiver (Digistat⁺2RF & Digistat⁺3RF)
- Suitable for combi-boilers and zone control (Digistat⁺2RF & Digistat⁺3RF)



GETTING TECHNICAL

Model:	Digistat ⁺ 3/+2	
	Battery	Mains
Power supply:	2 X 1.5V IEC LR6(AA) alkaline batteries	230V a.c. 50Hz
Switch type and rating:	SPDT 16(2)A 230V a.c. Volt free	
Min. recommended current:	10mA@24V a.c. (inductive)	
Wiring:	Designed for fixed wiring only, to comply with current IET wiring regulations (BS7671).	
Mounting:	Suitable for surface or conduit box mounting	
Battery life:	2 years typical	
Ambient temperature:	Operating 0°C to 40°C / Storage - 20°C to 55°C	
Ambient humidity (non condensing):	Operating 25% to 90% / Storage 15% to 95%	
Temperature range:	5°C to 32°C	
Control Accuracy:	+ 0.5K @ 20°C	
Control Algorithm:	TPI, TP	
Timing resolution:	1 minute	
Temperature resolution:	0.5°C	
Ball pressure test:	75°C	
Pollution situation:	Degree 2	
Protection level:	IP30	
Pollution Class:	2	
Software Class:	A	
Energy Class:	IV = 2% (Acc. EU 811/2013, 812/2013, 813/2013, 814/2013)	
Relevant EC directives:	2006/95/EC Low Voltage Directive 2004/108/EC Electromagnetic Compatibility Directive 1999/5/EC R&TTE Directive 2013/56/EU Battery Directive 2011/65/EU RoHS Directive	
Applied standards:	EN60730-1; EN60730-2-7; EN60730-2-9 EN 300 220-2; EN 301 489-3	

Digistat⁺ range wiring

Combi Boiler

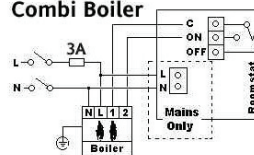

Basic Boiler with Zone Valve

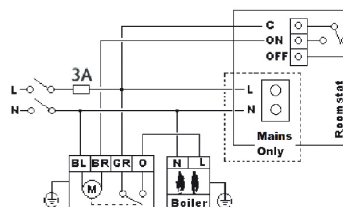

Basic Boiler

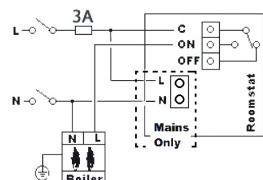

Digistat +2RF/+3RF Wireless Programmable Room Thermostats

In addition we have 2 programmable room thermostat wireless systems, a breakthrough in programmable thermostats. The 2 wireless systems available are the Digistat+2RF (24hour) and Digistat+3RF (5-2day/7day).



BENEFITS OF A COST EFFECTIVE WIRELESS SYSTEM:

- No carpets and floor-boards to lift
- No damage to wall coverings
- No unsightly surface wiring
- Positioning no longer restricted to areas accessible by cable runs
- No brick or plaster work to chase out
- No damage to fabrics and furnishings in the process

DIGISTAT+ & DIGISTAT+RF RANGE

Product	Part No.
Digistat+3 (Battery) 7 day 5-2 Day	22083
Digistat+2 (Battery) 24Hr	22084
Digistat+3 (Mains) 7 day 5-2 Day	22087
Digistat+2 (Mains) 24Hr	22088
Digistat+2RF (24hr) room thermostat & SCR	RF700
Digistat+3RF (5-2) / 7 day room stat & SCR	RF701
Digistat+2RF transmitter spare	22090
Digistat+3RF transmitter spare	22092
Digistat+SCR receiver spare	22149

Wiring - SCR Receiver:

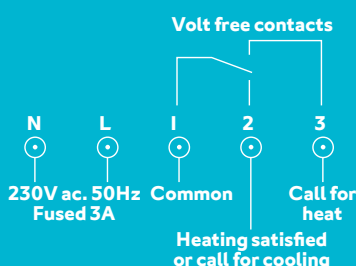

GETTING TECHNICAL

Model:	Digistat +2RF/+3RF	SCR (receiver)
Power supply:	2 X 1.5V IEC LR6(AA) alkaline batteries	230V a.c. 50Hz
Switch type and rating:	N/A	SPDT (voltage free) 2(I)A 230V a.c. or 24V a.c./d.c
Wiring:	No wiring required	Designed for fixed wiring only, to comply with current IET wiring regulations (BS7671).
Mounting:	Suitable for surface or conduit box mounting	Industry standard wall plate
Battery life:	2 years typical	N/A
Ambient temperature:	Operating 0°C to 40°C / Storage - 20°C to 55°C	
Ambient humidity (non condensing):	Operating 25% to 90% / Storage 15% to 95%	
Temperature range:	5°C to 32°C	
Control Accuracy:	+ 0.5K @ 20°C	
Control Algorithm:	TPI, TP	
Timing resolution:	1 minute	
Temperature resolution:	0.5°C	
Ball pressure test:	75°C	
Pollution situation:	Degree 2	
Protection level:	IP30	
Pollution Class:	2	
Software Class:	A	
Radio frequency:	433 MHz	
Radio Signal Range:	30m typically. The range may be affected by the composition / density and number of walls between the thermostat and receiver.	
Energy Class:	IV = 2% (Acc. EU 811/2013, 812/2013, 813/2013, 814/2013)	
Relevant EC directives:	2006/95/EC Low Voltage Directive 2004/108/EC Electromagnetic Compatibility Directive 1999/5/EC R&TTE Directive 2013/56/EU Battery Directive 2011/65/EU RoHS Directive	
Applied standards:	EN60730-1; EN60730-2-7; EN60730-2-9 EN 300 220-2; EN 301 489-3	

MiStat RF

Wireless Programmable Room Thermostat

The Drayton MiStat RF programmable thermostat is a fantastic product that makes everyone's life easier. It's wireless and comes pre-bound and with a signal strength indicator making it easy to install. The universal symbols and on-screen guide make programming simpler than ever.

FEATURES:

- Pre-bound two-way wireless connection
- Signal strength indication
- TPI, TP & On/Off algorithms
- Optimum or delayed start options
- Can be freestanding or wall mounted
- Eco mode screens – "power save" mode or "timed switch off"
- Memory saver function
- 3 Pre-set and easily adjustable lifestyle programmes
- 3 User programmes can be saved by name and restored
- Flexible service interval feature
- Automatic summer/winter time updates
- Timer override feature (boost)
- 12 or 24 hour clock
- Copy day feature
- Up to 8 events per day
- Enhanced holiday mode

MiSTAT RF

Product	Part No.
MiStat Programmable Thermostat + Receiver	MP710R9K0900
MiStat Programmable Thermostat	MP710R0S0900
MiStat Receiver	MR111MIS0900

Wiring

SCR Receiver:

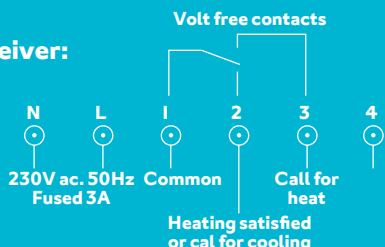

GETTING TECHNICAL

Model:	MiStatP	MiStatR (receiver)
Power supply:	2 X 1.5V IEC LR6(AA) alkaline batteries	230V a.c. 50Hz
Switch type and rating:	N/A	SPDT (voltage free) 2(I)A 230V a.c.
Wiring:	No wiring required	Designed for fixed wiring only, to comply with current IET wiring regulations (BS7671).
Mounting:	Suitable for surface mounting with wall-clip or freestanding with table stand	Industry standard wall plate
Battery life:	2 years typical	N/A
Ambient temperature:	Operating 0°C to 45°C / Storage – 20°C to 55°C	
Ambient humidity (non condensing):	Operating 25% to 90% / Storage 15% to 95%	
Temperature range:	5°C to 30°C	
Control Accuracy:	+ 0.5K @ 20°C	
Control Algorithm:	TPI, TP, On/Off	
Timing resolution:	1 minute	
Temperature resolution:	0.5°C	
Ball pressure test:	75°C	
Pollution situation:	Degree 2	
Protection Level:	IP30	
Pollution Class:	2	
Software Class:	A	
Radio frequency:	868.3 MHz Bi Directional	
Radio Signal Range:	30m typically. The range may be affected by the composition / density and number of walls between the thermostat and receiver.	
Energy Class:	IV = 2% (Acc. EU 811/2013, 812/2013, 813/2013, 814/2013)	
Relevant EC directives:	2006/95/EC Low Voltage Directive 2004/108/EC Electromagnetic Compatibility Directive 1999/5/EC R&TTE Directive 2013/56/EU Battery Directive 2011/65/EU RoHS Directive	
Applied standards:	EN60730-1; EN60730-2-7; EN60730-2-9 EN 300 220-2; EN 301 489-3	

SMI & SM2 Mechanical Timeswitches & Programmers

The SMI single channel timeswitch and SM2 twin channel programmer give style and ease of use to suit most domestic pumped and gravity heating systems.

FEATURES:

- Single and dual channel
- Advance feature
- Modern styling
- LED indication
- 4 position slide (ease of setting)
- Intuitive time setting for ON/OFF
- Suitable for gravity and pumped systems
- Positive switching of time
- Two ON/OFF time functions per day
- All day option
- Universal industry standard back-plate

SMI AND SM2

Product	Part No.
SMI	29205
SM2	29206

Wiring:

SINGLE CHANNEL: SMI TIMESWITCH

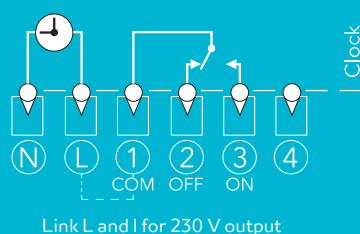

DUAL CHANNEL: SM2 PROGRAMMER

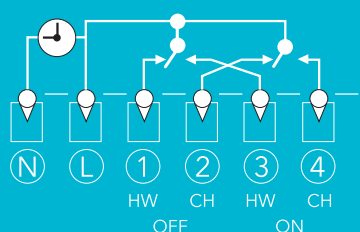

Drayton

by Schneider Electric



GETTING TECHNICAL

Model	SMI and SM2
Power supply:	230V a.c. +10% -10% 50Hz
Switch rating:	2(I)A 230V a.c. each switch
Wiring:	Designed for fixed wiring only, to comply with current IET wiring regulations (BS7671).
Mounting:	Industry standard wall plate
Output:	Programmers; 230V a.c. Timeswitches: according to supply to common terminal - volt-free contacts
Ambient temperature:	Operating: 0 to 45°C Storage: 0 to 50°C
Ambient humidity (non condensing):	Operating 25% to 90% Storage 15% to 95%
Programming resolution:	20 minutes
Ball Pressure Test Temperature:	75°C
Pollution Degree:	2
Rated Impulse Voltage:	2.5kV
Relevant EC Directives:	2006/95/EC Low Voltage Directive 2004/108/EC Electromagnetic Compatibility Directive 2013/56/EU Battery Directive 2011/65/EU RoHS Directive
Applied Standards:	EN60730-1; EN60730-2-7

Lifestyle LP and LPSi Electronic Timeswitches & Programmers

FEATURES:

- Easy to use
- Automatic summer/winter time change
- Memory saver – programme and clock never need resetting in the event of loss of power
- Easy to read, backlit screen
- New contemporary design
- Pre-set clock
- On/once/timed/off switching options
- 3 timing periods per day
- Programme advance buttons, with LCD indication
- Boost, giving 1, 2 or 3 hours with LCD indication
- Programme advance buttons
- Holiday Mode
- All programmers suitable for fully pumped or gravity heating systems
- Timeswitches are ideal for combination boilers and control of additional zones etc. (voltage free contacts)
- Universal backplate
- Part L Compliant (Part J in Scotland)
- Proven reliability

EXTRA FEATURES FOR LPSi

- Service period selectable
- Reduces comfort level
- Warning period
- Visual indication on LCD
- Audible alarm
- Backlit display flashes providing visual warning
- Separate reset unit (sold separately)

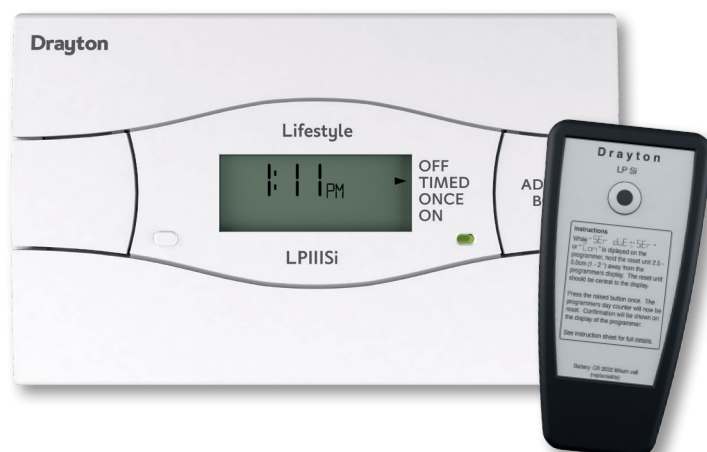

With all the features of Drayton's market leading LP time controls, the LPSi features a service interrupter to alert householders when their boiler service is due. Thirty days before the boiler is due to be serviced the LPSi enters a warning period. During this time, the backlit display flashes providing a visual warning and the resident can read when the service is due on the display. All buttons/programming features are fully functional during this time. If the boiler is not serviced despite the warnings, the LPSi will then reduce the temperature level in the property to a safe but uncomfortable level, encouraging the resident to call an engineer to check their heating system.

LP & LPSi ELECTRONIC TIME CONTROLS

Product	Timing Periods	Part No.
LPiII Timeswitch	24 hour	25477
LP7iII Timeswitch	7 day	25478
LP8iII Timeswitch	Universal Timeswitch (24hr, 5day/2day, 7day)	25463
LPiI2 Programmer	24 hour (common timings for heating & hot water)	25473
LP24i Programmer	24 hour (separate timings for heating & hot water)	25474
LP522 Programmer	5 day/2 day (separate timings for heating & hot water)	25475
LP722 Programmer	7 day (separate timings for heating & hot water)	25476
LP822 Programmer	Universal Programmer (24hr, 5day/2day, 7day)	25464
LPSi Reset Unit		25489
LP24iSi Programmer	24 hour (separate timings for heating & hot water)	25490
LP522Si Programmer	5 day/2 day (separate timings for heating & hot water)	25491
LP722Si Programmer	7 day (separate timings for heating & hot water)	25492
LPiIISi Timeswitch	24 hour	25493
LP7iIISi Timeswitch	7 day	25494

The Lifestyle LP and LPSi Range of programmers and time switches have a well established reputation for quality and reliability.

Now extra features make these popular products even easier to use for both installer and home-owner. The Lifestyle range has automatic summer/winter time adjustment, making the bi-annual summer/winter manual reset a thing of the past. In addition, the LP range has an accurate, preset clock, virtually eliminating the need for time adjustments through the product's life. The clock is pre-set at the factory, so installers can focus on completing other tasks instead of spending time setting or re-setting the clock during installation.

Available to suit most combination and conventional boiler systems, the time controls allow up to three time periods per day. LED's give an instant indication of the unit's operational status, while advance buttons allow additional control over the set programme. The LP range has large buttons and uncomplicated controls, and its streamlined design makes it one of the most visually appealing products in the market today. Lifestyle LP products are also supplied in Drayton's range of control packs for mid position or zone valve installations.



LP8II & LP822 UNIVERSAL TIME CONTROLS 24hr, 5day/2day or 7 day PROGRAMMING

GETTING TECHNICAL

Model	LP and LPSi
Power supply:	230V a.c. +10% -10% 50Hz
Switch rating:	2(1)A 230V a.c. each switch
Wiring:	Designed for fixed wiring only, to comply with current IET wiring regulations (BS7671).
Mounting:	Industry standard wall plate
Output:	Programmers; 230V a.c. Timeswitches: according to supply to common terminal - volt-free contacts
Ambient temperature:	Operating: 0 to 50°C / Storage: -20 to 50°C
Ambient humidity (non condensing):	Operating 25% to 90% / Storage 15% to 95%
Timing resolution:	1 minute
Programming resolution:	1 minute
Ball Pressure Test Temperature:	75°C
Pollution Degree:	2
Software Class:	A
Without mains power:	Display: Blank Time and Programme: Always retained
Rated Impulse Voltage:	2.5kV
Relevant EC Directives:	2006/95/EC Low Voltage Directive 2004/108/EC Electromagnetic Compatibility Directive 2013/56/EU Battery Directive 2011/65/EU RoHS Directive
Applied Standards:	EN60730-1; EN60730-2-7

Programmer internal wiring

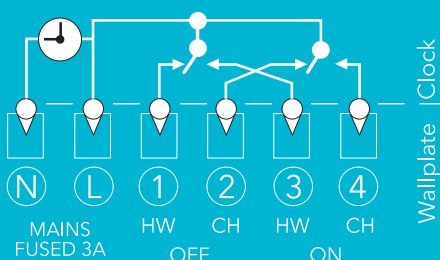

Timeswitch internal wiring

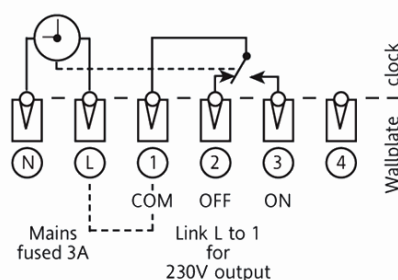

MiTime

Wired

Timeswitches & Programmers

Drayton's new range of time controls offer complete versatility providing the option of up to four channels with universal timing options. The industry standard backplate makes installation simple and the step-by-step on-screen guide means users probably won't even need their instructions to programme them.

FEATURES:

- Easitext step-by-step guide for simple programming
- Universally recognised buttons and symbols for easy use
- Large backlit screen with now and next information
- New 3/4 channel options for zoning
- 1, 2 or 3 hours boost with LCD indication
- Advance programme to the next on or off period
- Universal programming options: 24 hour, 5 day/2 day, or 7 day.
- Industry standard back plate for quick installation
- Flexible Service interval feature
- Enhanced holiday mode for one or multiple zones.
- Choice of 12 or 24 hour pre-set clock
- Memory saver - programme and clock never needs resetting in the event of power loss
- Automatic summer/winter time updates
- Access protection (screen lock)
- Auto, Always off, always on and all day options
- 3 pre-set and easily adjustable lifestyle programmes
- 3 user programmes can be saved
- Copy day feature
- Up to 4 time periods per day

NB. Programmers do not support Gravity systems



T71IR Timeswitch
1 Channel, universal
(7 day, 5day/2 day or 24 hour)



T72IR Programmer
2 Channel, universal
(7 day, 5day/2 day or 24 hour)



T742R Programmer
3/4 channel, universal
(7 day, 5/2 day or 24hour)
Perfect for zoning and multi-zoning

FEATURING NEW 'ADVANCED SERVICE INTERVAL'

- Flexible service interval mode (reminder, reduced comfort or off)
- Features reduced comfort (adjustable duration), off or warning only options
- Includes boost feature and audible alarm
- Gives you the option to input installer phone number so it displays when the service is due
- Installer can select the required settings

Wiring:

SINGLE CHANNEL

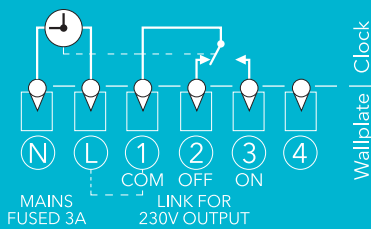

DUAL CHANNEL

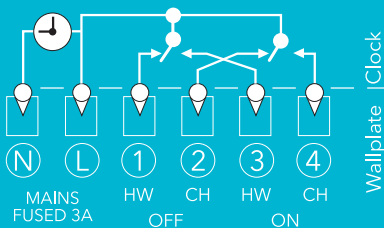

MULTI CHANNEL

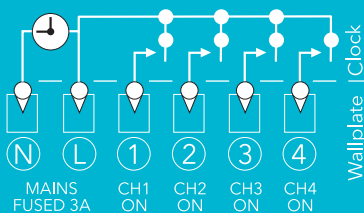

GETTING TECHNICAL

Model	MiTime
Power supply:	230V a.c. +10% -10% 50Hz
Switch rating:	2(I)A 230V a.c. each switch
Wiring:	Designed for fixed wiring only, to comply with current IET wiring regulations (BS7671).
Mounting:	Industry standard wall plate
Output:	Programmers; 230V a.c. Timeswitch: according to supply to common terminal - volt-free contacts
Ambient temperature:	Operating 0°C to 45°C (MiTime 3/4 channel 0° to 40°C) Storage - 20°C to 55°C
Ambient humidity (non condensing):	Operating 25% to 90% Storage 15% to 95%
Timing resolution:	1 minute
Programming resolution:	1 minute
Ball Pressure Test Temperature:	75°C
Pollution Degree:	2
Software Class:	A
Without mains power:	Display: Blank Time and Programme: Always retained
Rated Impulse Voltage:	2.5kV
Relevant EC Directives:	2006/95/EC Low Voltage Directive 2004/108/EC Electromagnetic Compatibility Directive 2013/56/EU Battery Directive 2011/65/EU RoHS Directive
Applied Standards:	EN60730-1; EN60730-2-7

WIRELESS ENABLED VERSIONS OF MITIME ARE ALSO AVAILABLE AS PART OF MITIME RF PACKS SEE PAGE 28 FOR DETAILS.

MiTIME

Product	Part No.
Single Channel Timeswitch	MT7IIRIA0900
Dual Channel Programmer	MT72IRIA0900
Multi Channel Programmer	MT742RIA0900

MiTime

MiTime RF Packs

MiTime RF Packs offer a hassle-free wireless solution designed to meet Part L building regulations. From basic addition of a wireless room thermostat using packs 1,2 or 3; to zoning in new and larger properties using Packs 4 and 5.

Wireless enabled timeswitch: 1 channel, universal
Wireless room thermostat: Includes table stand

Product	Part No.
MiTime RF Pack 1	MT710R9K0900
MiTime Single Channel Timeswitch	MT710RIS0900
MiStat Room Thermostat	MNII0R0S0900

Wireless enabled programmer: 2 channel, universal
Wireless room thermostat: Includes table stand

Product	Part No.
MiTime RF Pack 2	MT720R9K0900
MiTime Dual Channel Programmer	MT720RIS0900
MiStat Room Thermostat	MNII0R0S0900

Wireless enabled programmer: 2 channel, universal
Wireless room thermostat: Includes table stand
Wireless Cylinder Thermostat: Includes sensor

Product	Part No.
MiTime RF Pack 3	MT720M9K0900
MiTime Dual Channel Programmer	MT720RIS0900
MiStat Room Thermostat	MNII0R0S0900
MiStat Cylinder Thermostat	MCII0C0S0900
MiStat Cylinder Sensor	MCII0S0S0900

Wireless enabled programmer: 3/4 channel, universal
2 x Wireless room thermostat: Includes table stands

Product	Part No.
MiTime RF Pack 4	MT740R9K0900
MiTime Multi Channel Timeswitch	MT740RIS0900
MiStat Room Thermostat	MNII0R0S0900

Easy thermostat upgrade

ERP RATING 2%

Pack 1   

Easy thermostat upgrade

ERP RATING 2%

Pack 2   

Easy thermostat upgrade

ERP RATING 2%

Pack 3    

Ideal for zoning

ERP RATING 2%

Pack 4   

Wireless enabled programmer: 3/4 channel, universal
 2 x Wireless room thermostat: Includes table stands
 Wireless Cylinder Thermostat: Includes sensor

Product	Part No.
MiTime RF Pack 5	MT740M9K0900
MiTime Multi Channel Programmer	MT740RIS0900
MiStat Room Thermostat	MNII0R0S0900
MiStat Cylinder Thermostat	MCII0C0S0900
MiStat Cylinder Sensor	MCII0S0S0900



GETTING TECHNICAL

Model:	MiTime RF	MiStat thermostat	MiStat cylinder
Power Supply:	230V a.c. +10% -10% 50Hz	2 X 1.5V IEC LR6(AA) alkaline batteries	
Switch Rating:	2 (I) A 230V a.c. each switch	N/A	
Wiring:	Fixed wiring only, to comply with current IET regulations (BS7671)	No wiring required	Ø 0.5mm ² 2 core cable between sensor and MiStat
Mounting:	Industry standard wall plate	Wall clip or table stand	MiStat: Wall clip Sensor: Direct mounting onto cylinder
Battery life:	N/A	2 years typical	
Ambient Temperature:	Operating: 0° to 45°C (MiTime 3/4 channel 0° to 40°C, MiStat C 0° to 50°C) Storage: -20°C to 55°C		
Ambient humidity (non condensing):	Operating 25% to 90% / Storage 15% to 95%		
Temperature Range:	5 °C - 30 °C	40 °C - 70 °C	
Control Accuracy:	+ 0.5K @ 20°C	+0 / -8°C	
Control Algorithm:	TPI, TP, On/Off	On/Off	
Timing resolution:	1 minute		
Temperature resolution:	0.5°C	5°C	
Ball Pressure Test Temperature:	75°C		
Pollution Degree:	2		
Energy Class:	IV = 2% (Acc. EU 811/2013, 812/2013, 813/2013, 814/2013)		
Software Class:	A		
Without Mains Power:	Display: blank; Time: always kept Program times: always preserved	N/A	
Rated Impulse Voltage:	2.5kV	N/A	
Radio Frequency:	868.3MHz (Bi-directional communication)		
Radio Signal Range:	30m typically. The range may be affected by the composition / density and the number of walls between the MiTime and MiStats.		
Relevant EC Directives:	2006/95/EC Low Voltage Directive - 2004/108/EC Electromagnetic Compatibility Directive 1999/5/EC R&TTE Directive - 2013/56/EU Battery Directive - 2011/65/EU RoHS Directive		
Applied Standards:	EN60730-1; EN60730-2-7; EN60730-2-9 / EN 300 220-2; EN 301 489-3		

MiTIME RF PACK SELECTOR

MiTime RF Pack	Contents	Part No.	Recommended Application*	Combination	Conventional	Zone Control
Pack 1	1 Channel, universal Programmer/Receiver, RF Room Thermostat	T710R	Provides time and temperature control, ideal for combination boilers. Upgrade your controls without the need for any re-wiring. Add an extra thermostat for basic zone control.	✓		
Pack 2	2 Channel, universal Programmer/Receiver, RF Room Thermostat	T720R	Recommended for conventional boilers. Upgrade your time control and thermostat, and use with an existing wired cylinder thermostat. No additional wiring required.	✓	✓	
Pack 3	2 Channel, universal Programmer/Receiver, RF Room Thermostat, RF Cylinder Thermostat	T720M	Ideal for conventional boilers. Provides time and temperature control for heating and hot water. Wireless cylinder thermostat to help meet Part P regulations. No additional wiring.		✓	
Pack 4	3/4 Channel, universal Programmer/Receiver, RF Room Thermostat x 2	T740R	Ideal for conventional boilers in new/larger properties. Existing cylinder thermostat can be wired in, and 2 wireless thermostats included for zone control of heating.	✓	✓	✓
Pack 5	3/4 Channel, universal Programmer/Receiver, RF Room Thermostat x 2, RF cylinder thermostat	T740M	Designed for meeting regulations in new/larger properties. Provides a wireless cylinder thermostat for hot water and two thermostats for zone control of heating. A second cylinder thermostat or third heating zone can be added if required.		✓	✓

* Recommended applications, also suitable for other applications.

LP Clip-in Controls

For Worcester boilers*

FEATURES:

- Clip-in controls
- Suitable for Worcester boilers
- 4 pack options
- Simple wireless installation
- Wireless receiver built into the LP devices
- Signal strength indicator
- 7 day programmes
- 3 on/off periods per day
- Automatic summer/winter time updates
- Pre-programmed on/off periods
- Dedicated advance buttons
- 12 or 24 hour back-lit digital display
- Holiday function
- Pre-wired with PCB connector

*Not recommended for use with Worcester Greenstar 25i & 30i models.

LP20 DUAL CHANNEL PROGRAMMER

The LP20 is a dual channel programmer that simply clips into the boiler providing control of central heating, and hot water if required.



Product	Part No.	Replaces Worcester product
LP20 Dual Channel Programmer	25039DR	7716 192 038

LPIORF SINGLE CHANNEL PROGRAMMER & DIGISTAT +2RF

Wirelessly bound, the LPIORF and

Digistat+2RF provide control of heating and hot water. The 24 hour programmable room thermostat function of the Digistat+2 RF enables time and temperature control of the heating and the LPIORF offers 7 day hot water control.



Product	Part No.	Replaces Worcester product
LPIORF Single Channel Programmer & Digistat +2RF	RF560DR	7716 192 052
LPIORF Single Channel Programmer spare	22589DR	8716 106 667 0
Digistat+2RF thermostat spare	22090	-

LPIORF SINGLE CHANNEL PROGRAMMER & DIGISTAT +3RF

Wirelessly bound, the LPIORF and Digistat+3RF provide control of heating and hot water. The Digistat+3RF enables flexible 5day/2day or 7 day time and temperature scheduling of the heating and the LPIORF offers 7 day hot water control.



Product	Part No.	Replaces Worcester product
LPIORF Single Channel Programmer & Digistat+3RF	RF561DR	7716 192 053
LPIORF Single Channel Programmer spare	22589DR	8716 106 667 0
Digistat+3RF thermostat spare	22092	-

LP20RF DUAL CHANNEL PROGRAMMER & DIGISTAT +RF

The LP20RF is a dual channel programmer providing 7 day time control of heating and hot water. The LP20RF is wirelessly linked to the Digistat+RF which provides temperature control of the heating. The traditional dial on Digistat+RF makes it really simple for homeowners to adjust the temperature as required.



Product	Part No.	Replaces Worcester product
LP20RF Dual Channel Programmer & Digistat+RF	RF562DR	7 716 192 054
P20RF Dual Channel Programmer spare	22590DR	8 716 106 669 0
Digistat+RF thermostat spare	31003	-



GETTING TECHNICAL

Model:	LP20	LP20RF Receiver	LPIORF Receiver	Digistat+RF Transmitter Thermostat	Digistat +2RF Transmitter Thermostat	Digistat +3RF Transmitter Thermostat
Power supply:	24Vd.c. less than 65mA			2xAA 1.5V alkaline batteries		
Ambient operating temperature:	0°C to +50°C			0°C to +40°C		
Ambient Storage Temperature:	N/A			-20°C to 55°C		
Humidity operating range:	30 - 95% non-condensing up to 45°C			25 - 90% non condensing up to 45°C		
Temperature setting range:	N/A			5°C to 30°C	5°C to 32°C	
Control Accuracy:	± 1 sec/day @ 25°C			+ 0.5°C @ 20°C		
Battery life:	N/A			approx. 2 years (with alkaline batteries)		
Battery backup time & date:	10 years min.					
Timing resolution:	1 minute					
Hot water &/or Central heating Programs:	7 days			N/A	1 day	7 days
Hot water pre-heat settings:	3 ON / 3 OFF			N/A		
Central heating settings:	3 ON / 3 OFF		N/A		6 per day	
Radio frequency:	N/A	433 MHz				
Radio signal range:	N/A	30m typically. The range may be affected by the composition / density and number of walls between the thermostat and receiver.				
Mounting:	Boiler mounted			Suitable for surface mounting		
Wiring:	No wiring required					
Class of operation:	II			N/A		
Class of protection / Degree of protection:	IP20	IP24		IP30		
Pollution Class:	2					
Software Class:	A					
Ball Pressure Test:	90°C					
Energy Class:	N/A	IV = 2% (Acc. EU 811/2013, 812/2013, 813/2013, 814/2013)				
Relevant EC Directives:	2006/95/EC Low Voltage Directive 2004/108/EC Electromagnetic Compatibility Directive - 1999/5/EC R&TTE Directive 2013/56/EU Battery Directive - 2011/65/EU RoHS Directive					
Applied Standards:	EN60730-1; EN60730-2-7; EN60730-2-9 EN 300 220-2; EN 301 489-3					

miGenie®

Smart made simple

CONTROL YOUR HEATING AND HOT WATER FROM WHEREVER YOU ARE

INTERNET CONNECTED THERMOSTAT

miGenie is the fantastic new range of internet connected heating products that that will add a touch of magic to your life.

SMART MADE SIMPLE

If you are asked for internet connected controls miGenie is the best option. But Why? miGenie is the perfect combination of familiarity and modern technology. The standard backplate means you can upgrade in minutes; the pre-bound two-way wireless connection means units are ready to go straight out of the box; and the signal strength indicator ensures correct positioning first time. All that's left to do is plug the internet gateway into the router and the mains and you're done - installation can be done and dusted in just 10 minutes.

Benefit from familiar products with a modern twist.

miGENIE FEATURES & BENEFITS

INSTALLATION BENEFITS

- Familiar installation
- Standard industry backplate for easy upgrade
- No wiring needed
- Pre-bound 2-way wireless connection
- Signal strength indicator for correct placement
- Quick & simple to install
- Devices pre-bound out of the box

USER BENEFITS

- iOS and Android APP for smartphone, tablet and Apple Watch
- Intuitive programming via app or programmer
- Freestanding or wall mounted thermostat
- Step-by-step on-screen directions
- Familiar buttons & icons
- Now & next information display
- Automatic app upgrades

DOWNLOAD THE DEMO APP



Visit www.mi-genie.co.uk for more details



miGENIE PRODUCT RANGE

Internet Connected Thermostat Kits	Pack Contents	Part No.
miGenie Wish 1: Internet connected single channel thermostat kit.	Single channel controller, room thermostat, internet gateway	MT714R9K0900
miGenie Wish 2: Internet connected dual channel thermostat kit.	Dual channel controller, room thermostat, internet gateway	MT724R9K0900
miGenie Wish 3: Internet connected multi channel thermostat kit.	Multi channel controller, 2 x room thermostat, internet gateway	MT744R9K0900

Spares	Part No.
Single Channel Controller	MT714R9S0900
Dual Channel Controller	MT724R9S0900
Multi Channel Controller	MT744R9S0900
Room thermostat	MN114R0S0900
Internet gateway	MGI04M3S0900

PRODUCT FEATURES

- iOS and Android app for smartphone, tablet and Apple Watch
- Single, dual & multi channel versions
- Universal programming – 24 hour, 5day/2day or 7 day programming
- Can be used as a programmer or programmable thermostat (when thermostat is bound)
- Provides optimum accuracy and performance for heating and hot water applications
- Boost feature allowing 0.5 to 23.5 hours override
- Advance / Override function to temporarily adjust schedule until next event
- If the internet connection fails ALL functionality will still be available from the in-home equipment
- Future proof – over the air upgrades allowing continual improvement
- Up to 8 events per day
- Copy day feature to make scheduling quicker and easier
- Default pre-set programme
- TPI and TP algorithms
- Enhanced holiday mode
- Backlit display

INSTALL IN JUST 10 MINUTES

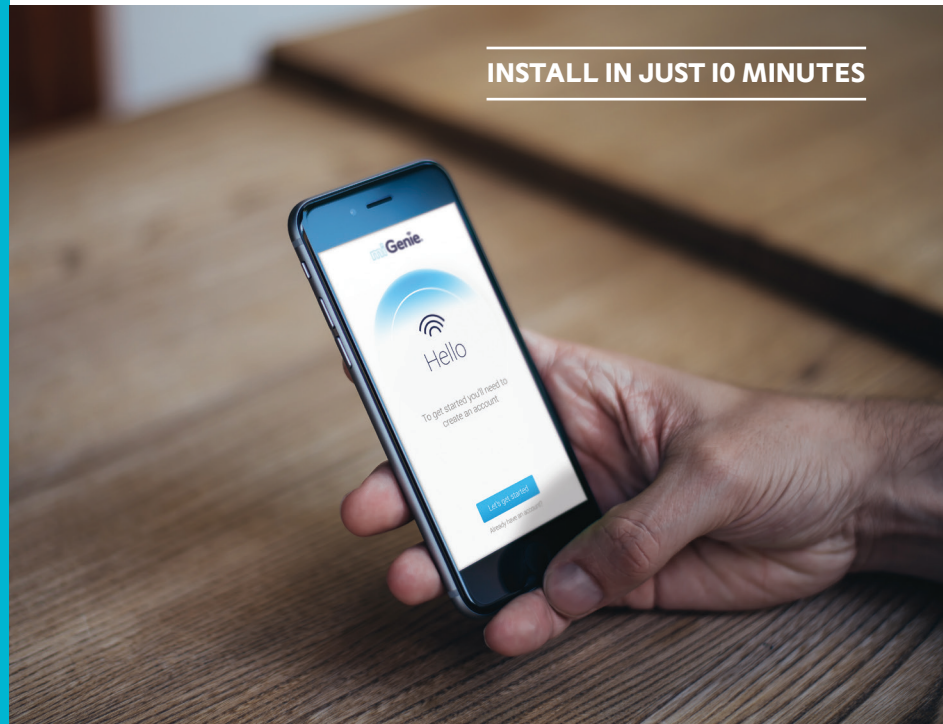

GETTING TECHNICAL

Model:	miGenie controller	miGenie thermostat	miGenie gateway
Power Supply:	230V a.c. +10% -10% 50Hz	2 X 1.5V IEC LR6(AA) alkaline batteries	5V d.c. 1A USB Micro-B
Switch Rating:	2 (I) A 230V a.c. each switch	N/A	
Wiring:	Fixed wiring only, to comply with current IET regulations (BS7671)	No wiring required	
Mounting:	Industry standard wall plate	Wall bracket or table stand	Table top
Battery life:	N/A	2 years typical	N/A
Ambient Temperature:	Operating 0°C to 45°C (miGenie controller 3 / 4 channel 0° to 40°C) Storage – 20°C to 55°C		
Ambient humidity (non condensing):	Operating 25% to 90% / Storage 15% to 95%		
Temperature Range:	5 °C - 30 °C		
Control Accuracy:	+ 0.5K @ 20°C		
Control Algorithm:	TPI, TP		
Timing resolution:	1 minute		
Temperature resolution:	0.5°C		
Ball Pressure Test Temperature:	75°C		
Pollution Degree:	2		
Software Class:	A		
Without Mains Power:	Display: blank; Time: always kept Program times: always preserved	N/A	
Rated Impulse Voltage:	2.5kV	N/A	
Radio Frequency:	868.3MHz (Bi-directional communication)		
Radio Signal Range:	30m typically. The range may be affected by the composition / density and the number of walls between the miGenie products		
Energy Class:	IV = 2% (Acc. EU 811/2013, 812/2013, 813/2013, 814/2013)	N/A	
Relevant EC Directives:	2006/95/EC Low Voltage Directive - 2004/108/EC Electromagnetic Compatibility Directive 1999/5/EC R&TTE Directive - 2013/56/EU Battery Directive - 2011/65/EU RoHS Directive		
Applied Standards:	EN60730-1; EN60730-2-7; EN60730-2-9 - EN 300 220-2; EN 301 489-3		

Two Port & Mid Position Valves

Motorised Valves

The Drayton 2 port, diverter and mid-position valves are available in 22mm and 28mm.

All models feature "snap-on" actuators and have industry-standard wiring and dimensions.

FEATURES:

- "Snap-on" actuators can be removed at the push of a button
- 2 Port, diverter and mid-position available in 22mm and 28mm
- 100% tight shut off
- Manual lever and valve position indicator
- Spring return
- Replaceable actuators
- Replaceable motors
- Simple industry-standard wiring
- Complete assembly easily replaces most makes

GETTING TECHNICAL

Model	Motorised Valves
Standard motor voltage	230V a.c. 5 watts
Valve operation 2 Port: Diverter: Mid-position:	Standard valves – energise to open Energise to open port A Heating, hot water or a combination of both
Operating time 2 Port: Diverter:	Motor 14 secs., spring return 6 secs. Motor 12 secs., spring return 6 secs.
Max. static pressure	8.6 bar
Max. differential pressure	0.7 bar (See page 38)
Water temperature	93°C max., 2°C min
Max. ambient temperature	52°C
Valve body	Brass forging
Connections	22mm compression; 28mm compression
Lead length	1 Metre
Switch ratings	24v – 230V a.c. 3(l)A



MOTORISED VALVES

Product	Part No.
Complete valve and actuator	
22mm 2 Port zone valve - 5 wire SPST switch	27100
22mm Mid-position valve	27101
22mm 3 Port diverter valve - no switch	27102
22mm 3 Port diverter valve - 5 wire SPST switch	27111
28mm 2 Port zone valve - 6 wire SPDT switch	27205
28mm Mid-position valve	27206
28mm 3 Port diverter valve - no switch	27207

Spare valve bodies	
22mm 2 Port body	27600
22mm 3 Port body	27602
28mm 2 Port body	27601
28mm 3 Port body	27603
3/4" 2 Port body	27621
3/4" 3 Port body	27622
1" 2 Port body	27623
1" 3 Port body	27624

Spare actuators	
3 Wire Zone valve actuator - no switch 230V	27652
5 Wire Zone valve actuator - SPST switch 230V	27650
6 Wire Zone valve actuator - SPDT switch 230V	27653
3 Wire Zone valve actuator - no switch 24V	27654
5 Wire Zone valve actuator - SPST switch 24V	27656
6 Wire Zone valve actuator - SPDT switch 24V	27657
Mid-position actuator 230V	27651

Spare motor	
Synchronous Motor Pack	27011

Thermostatic Radiator Valves (TRVs)

Drayton is the leading UK manufacturer of TRVs. Drayton has a comprehensive range to suit all applications from wax filled TRVs to top-of-the-range liquid filled TRVs that offer the ultimate in accuracy and responsiveness.

WHY USE TRVS?

Used to control the temperature in individual rooms, the TRV helps homeowners to be more energy efficient by preventing rooms from overheating, helping to reduce energy bills. Also, the liquid-fill versions ensure optimum sensitivity, increasing the reaction speed to temperature changes, which in turn further reduces energy consumption and wastage.

According to research carried out at the University of Salford in 2013 adding TRVs to a heating system with an existing room thermostat will give a potential annual saving of £289.37!

KEY BENEFITS:

- Keymark approved to EN215 ensuring quality, reliability, energy saving and safety
- Attractive design
- Full range of accessories; automatic by-pass valves, pushfit elbows and lockshield valves
- Drayton TRV heads are designed to be interchangeable with any other valve body in the Drayton TRV range
- All Drayton TRV sensing heads feature range limiting to prevent tampering
- Complete range to suit all budgets

Drayton

by Schneider Electric



**Top of the
range A-Rated TRV4**



**Mid Range
RT414**



**Standard
Range
RT313**



**Entry Level
RT212**



A rated efficiency for TRV4 White & Classic

KEY FEATURES:

A-Rated TRV4

- Awarded an A Rating for energy efficiency
- Contemporary iconic design
- Ultra sensitive liquid filled chrome head
- Easy to clean – no dust traps
- Frost protection position
- Stylish all-chrome option
- TRV4 Chrome is ideal for towel rails

RT414

- Fast acting liquid filled sensor
- Compact head design

RT313

- Easy-grip adjusting cap
- Cost effective solution

RT212

- Lower cost wax-sensor
- Entry level offering

VALVE BODY FEATURES COMMON TO ALL TRVs:

- Non-stick internals
- Presetting: radiator can be balanced from the TRV
- 15mm angle can be flow or return mounted both vertically or horizontally

RT212, RT313 & RT414

Thermostatic Radiator Valves

The Drayton TRVs are manufactured in our UK factory in Plymouth and are rigorously tested to conform to the Keymark EN215 standard which is recognised throughout Europe.

The 15mm angled valve can be mounted vertically or horizontally on flow or return.

COMMON FEATURES:

- Compact design
- 12°C to 29°C setting range
- Non-stick valve internals
- Range limiting
- 8°C frost position
- Positive off position
- Double gland seal
- Reverse flow body (15mm angle)
- Pre-setting as standard
- Radiators can be balanced from the TRV
- White wheelhead caps available (part no. 07 35 123) – converts valve body into balancing/isolating valve to replace lockshield
- Chrome caps available, used to replace plastic decorator caps Part No 06222 09 00 01
- Range of adaptors available for plastic (PEX) and multi-layer pipe

For commissioning instructions see page 78



GETTING TECHNICAL

Model	
Maximum Sensor Operating Temperature	50°C
Setting numbers	1 to 6
* Frost protection	8°C
Temperature setting range	Approx. 12°C to 29°C
Sensitivity	0.22mm/°C

EN215 KEYMARK TEST

	RT212	RT313	RT414
Hysteresis	0.7K	0.7K	0.7K
Water temp. Influence	0.9K	0.9K	1K
Differential pressure influence	0.15K	0.15K	0.15K
Response Time	20mins	20mins	22mins

RT414

KEY FEATURES:

- Accurate liquid-filled sensor
- Stylish head design

RT414 Thermostatic Radiator Valve

Product	Part No.
RT414 Sensing head only	10 10 099
RT414 with 15mm angle valve	10 10 015
RT414 with 15mm straight valve	10 10 115
RT414 with 15mm angle valve & Lockshield	10 10 260
RT414 with 15mm angle & DOTP Lockshield	10 10 264

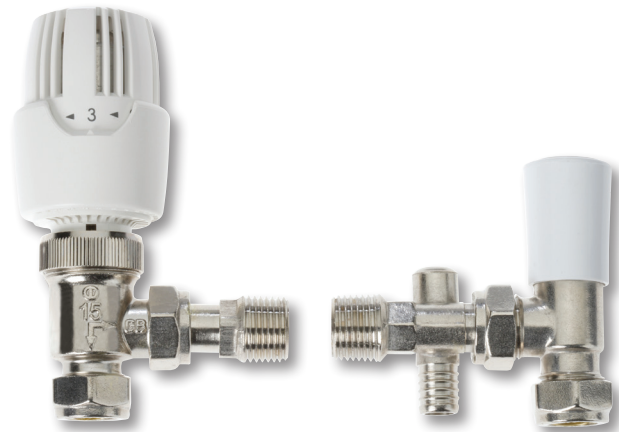

RT313

KEY FEATURES:

- Low-cost wax sensor
- Easy-to-turn adjusting cap

RT313 Thermostatic Radiator Valve

Product	Part No.
RT313 with 15mm angle valve	08 48 015
RT313 with 15mm straight valve	08 48 115
RT313 with 15mm angle & lockshield	08 48 260
RT313 with 15mm angle & DOTP lockshield	08 48 259

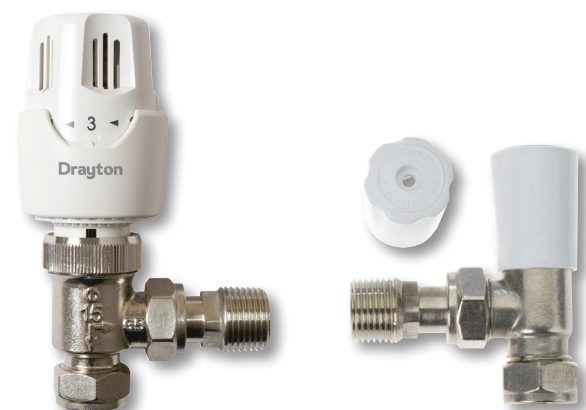

RT212

KEY FEATURES:

- Low-cost wax sensor
- Entry level model

RT212 Thermostatic Radiator Valve

Product	Part No.
RT212 with 15mm angle valve	08 08 015
RT212 with 15mm straight valve	08 08 115
RT212 with 15mm angle & lockshield	08 08 260
RT212 with 15mm angle & DOTP lockshield	08 08 264
RT212 with 10mm angle and lockshield	08 08 273

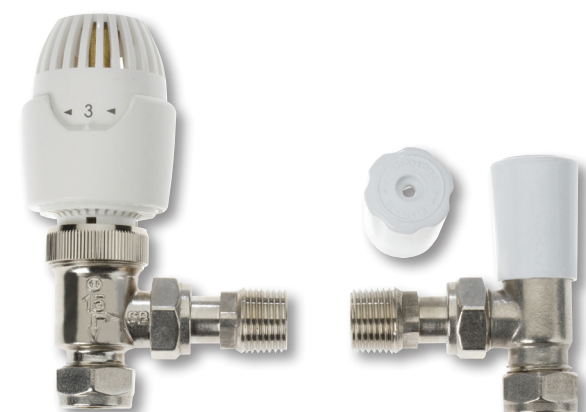

TRV4

Thermostatic Radiator Valve

The TRV4 Classic and NEW TRV4 White have achieved the highest A Rating for energy efficiency under the certification scheme of the European valve manufacturers association (Tell.eu).

The rating is based on how quickly a TRV reacts to changes in room temperature; how effectively it maintains stable room temperature; and how it performs after changes in water temperature and system pressure. Replacing a less efficient TRV with the Drayton A Rated TRV4 will show immediate and real saving in energy usage.

Over and above energy efficiency the TRV4 sets the standards for design, performance and quality. The TRV4 range includes matching chrome lockshields and pushfit packs to suit most domestic and commercial heating systems.

FEATURES:

- Awarded an A Rating for energy efficiency
- Contemporary slim-line design
- Ultra sensitive liquid-filled sensor
- Easy to clean smooth surfaces
- Half/full click stop settings
- Frost protection position
- Two stylish options including Classic and White
- Complete with chrome-plated valves
- Non-stick internals
- Pre-setting as standard
- Double gland seal

GETTING TECHNICAL

TRV4 Thermostatic Radiator Valve	Integral sensor	Remote sensor
Maximum sensor temperature	50°C	
Setting numbers	1 to 5 then MAX	1 to 7 then MAX
* Frost protection	Below 8°C	
Temperature setting range	1 to max = approx 10°C to 30°C	
Sensitivity	0.22mm/°C	
Hysteresis	0.4 K	0.6 K
Water temperature influence	0.8 K	0.4 K
Differential pressure influence	0.15 K	0.10 K
Response time	20 minutes	





TRV4 White



TRV4 Classic



TRV4 Chrome

TRV4

Product	Part No.
TRV4 White	
Sensing head only	07 07 007
With 15mm angle valve	07 07 015
With 15mm straight valve	07 07 115
With 15mm angle valve and lockshield	07 07 260
TRV4 Classic	
Sensing head only	07 25 006
With 15mm angle valve	07 05 150
With 15mm straight valve	07 05 151
With 15mm angle valve and lockshield	07 05 180
Sensing head with 2m remote sensor	07 25 007
Sensing head with 6m remote sensor	07 25 008

TRV4 Chrome

Sensing head only	07 03 013
With 15mm angle valve	07 05 150C
With 15mm straight valve	07 05 151C
With 15mm angle valve and lockshield	07 05 170

TRV4 Accessories and Adapters

Product	Part no.
16 x 2mm PEX/multi layer pipe adapter (5 Pack)	07 35 016
15 x 8mm Copper adapter (50 Pack)	07 35 408
15 x 10mm Copper adapter (50 Pack)	07 35 410
2m extension kit to mount head away from radiator	07 55 002
6m extension kit to mount head away from radiator	07 55 006
Tamper Guard (6 Pack)	07 35 269
White manual wheel head/isolating cap	07 35 123
Pre Setting Key	07 35 162



Scan the QR code to view our TRV4 installation video



Lockshields & Manual Valves

Suitable for domestic radiators and towel rails, available in either chrome or satin nickel finish to suit the Drayton TRV range.

15mm LS+integral DO
part no 08 08 903

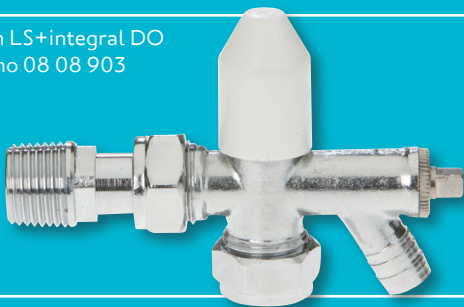

10mm PF elbow in chrome
Part No 07 05 904
10mm PF elbow in satin
Part No 08 08 904

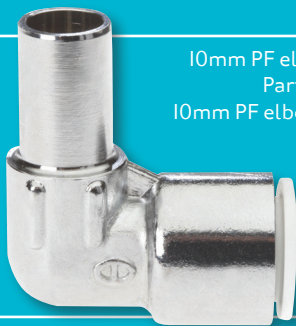

15mm DSO TP Chrome
Part No 07 05 902

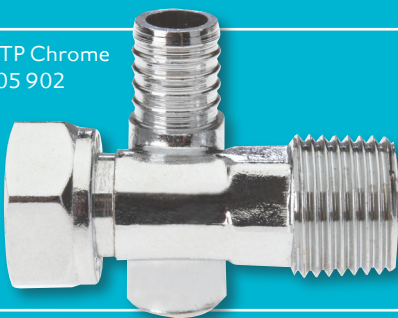

10mm Comp Elbow Part No
08 08 907
15mm Comp Elbow Part No
08 08 908



GETTING TECHNICAL

Model	Lockshield and Manual Valve
Maximum working pressure	10 bar
Maximum working pressure	3 bar (Push-fit)
Maximum differential pressure	0.6 bar
Recommended differential pressure	0.2 bar
Maximum ambient temperature	50 °C
Maximum flow water temperature	120 °C
Maximum flow water temperature	110 °C (Push-fit)
Connections	Compression fittings meet EN 1254-2
Standards	Conforms to BS 2767-10

CHROME FINISH TO MATCH TRV4

Product	Part no.
15mm Angle lockshield with white cap	07 05 900
15mm Angle lockshield with drain off tap	07 05 901
15mm Drain off tap	07 05 902
10mm Push-fit elbow	07 05 904
15mm Push-fit elbow	07 05 905
15mm Straight lockshield with white cap	07 05 906
15mm Angle with chrome cap	07 15 215
15mm Straight with chrome cap	07 15 216
10mm Compression elbow	07 05 907
15mm Compression elbow	07 05 908

SATIN NICKEL TO MATCH RT212, RT313 AND RT414

Product	Part no.
15mm Angle lockshield with white cap	08 08 900
15mm Angle lockshield with drain off tap	08 08 901
15mm Drain off tap	08 08 902
15mm Angle lockshield with integral drain off tap	08 08 903
10mm Push-fit elbow	08 08 904
15mm Push-fit elbow	08 08 905
15mm Straight lockshield with white cap	08 08 906
10mm Compression elbow	08 08 907
15mm Compression elbow	08 08 908

EB Body Range & Adaptors

EB BODY AND ADAPTOR RANGE FEATURES:

- PES internals, these have proved resistant to sticking in systems that are installed in hard water areas
- Pre-setting as standard
- Double gland seal, top seal replaceable without draining down
- Reverse flow 15mm angle body can be mounted on the radiator flow or return

METRIC FITTINGS

PRODUCT RANGE

Body type	Description	Part No.
	10mm angle	EB 10 A 07 15 182
	10mm straight	EB 10 S 07 15 183
	15mm angle	EB 15 A 07 15 180
	15mm straight	EB 15 S 07 15 181
	15mm corner angle left	EB 15 CAL 07 15 196
	15mm corner angle right	EB 15 CAR 07 15 197

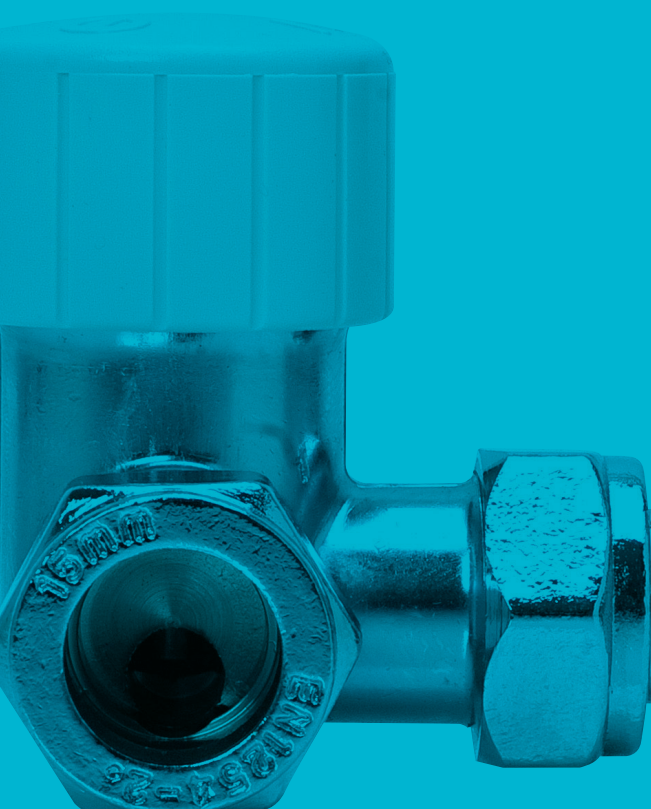

Commercial Radiator Controls

Drayton now offers a complete range of radiator controls for commercial applications. Typically using iron or steel pipe in imperial dimensions, these applications require a range of high-quality fittings with greater mechanical strength.

The Drayton range includes valves and lockshields for commercial applications as well as a RadPack containing TRV4 head, 1/2" angle valve and lockshield.

COMMERCIAL LOCKSHIELDS

FEATURES:

- Superior mechanical strength in standard D-Series valve dimensions
- Conforms to BS2767
- Satin-nickel finish to match EB valves
- 3/8" versions available on demand

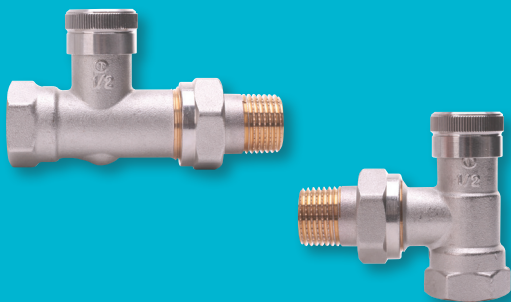

COMMERCIAL LOCKSHIELDS

Product	Part No.
TRV4 commercial radiator pack (TRV4 head with 1/2" angle valve and 1/2" angle lockshield)	07 05 187
1/2" Angle	08 08 920
1/2" Straight	08 08 921
3/4" Angle	08 08 924
3/4" Straight	08 08 925

MAX FLOW (FULLY OPEN) KVS

		Connections		Flow Limitation: Kv-values (m ³ /h) for number of turns											
Type	Prod. No.	Sys.	Rad.	0.25	0.50	0.75	1.00	1.50	2.00	2.50	3.00	3.50	4.00	Kvs	
DN 15 ang.	08 08 920	1/2"	1/2"	0.2	0.4	0.5	0.65	1	1.3	1.7	1.9	2.1	2.3	2.5	
DN 15 Str.	08 08 921	1/2"	1/2"	0.2	0.4	0.5	0.65	1	1.3	1.7	1.9	2.1	2.3	2.5	

TRV4 COMMERCIAL PACKS

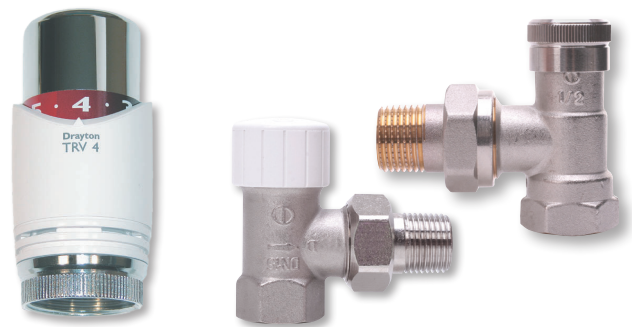

GETTING TECHNICAL

Lockshields with manual adjustment via allen key



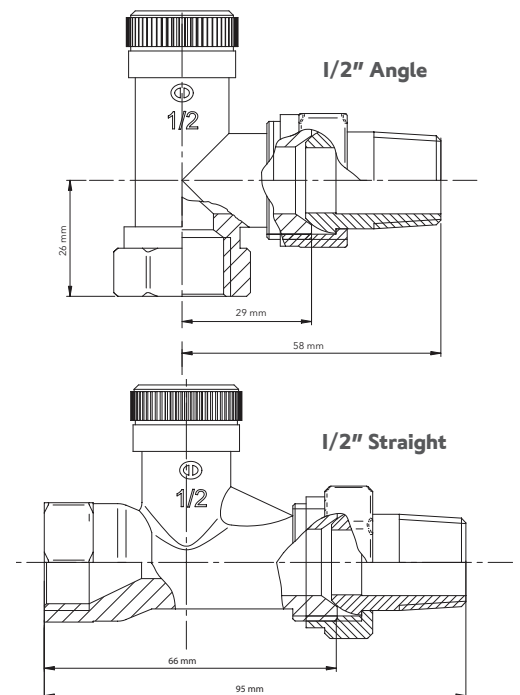

Finish:	Satin Nickel plated, ENI2540
Maximum working pressure:	10 bar
Test Pressure:	16 bar
Maximum ambient temperature:	50°C
Maximum flow water temperature:	120°C



Commercial Valves

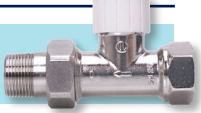
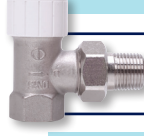
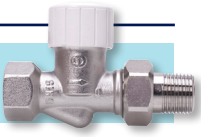
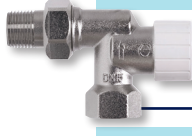



TWO-PIPE SYSTEMS

PRODUCT RANGE

Body type	Description	Part No.
 3/8" angle	EB 3/8" A	07 15 190
 3/8" straight	EB 3/8" S	07 15 191
 1/2" angle	EB 1/2" A	07 15 214
 1/2" straight	EB 1/2" S	07 15 185
 1/2" side angle	EB 1/2" SA	07 15 179
 1/2" corner angle left	EB 1/2" CAL	07 15 193
 1/2" corner angle right	EB 1/2" CAR	07 15 194
 3/4" angle	EB 3/4" A	07 15 186

SINGLE-PIPE SYSTEMS

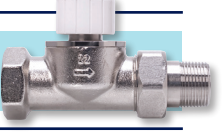
PRODUCT RANGE

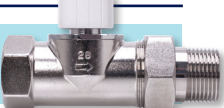
Body type	Description	Part No.
 1/2" angle single pipe	EB 1/2" ASP	07 15 621
 1/2" straight single pipe	EB 1/2" SSP	07 15 624
 3/4" angle single pipe	EB 3/4" ASP	07 15 622
 3/4" straight single pipe	EB 3/4" SSP	07 15 625
 1" angle single pipe	EB 1" ASP	07 15 623
 1" straight single pipe	EB 1" SSP	07 15 626

EB Flow Capacity

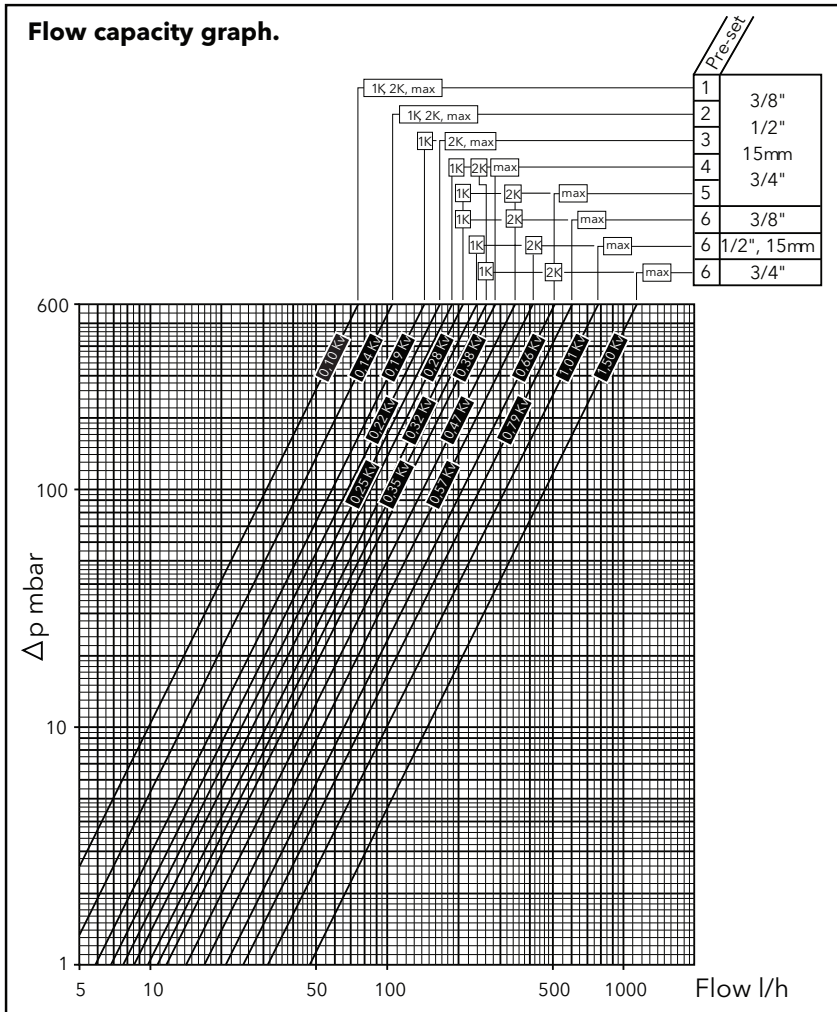

PRE-SETTING	Pre-setting Nr.	Kv (1K)	Kv (2K)	Kvs (max)	a (2K)
EB 3/8"	1	0.10	0.10	0.10	-
	2	0.14	0.14	0.14	-
	3	0.19	0.22	0.22	-
	4	0.25	0.35	0.38	0.16
	5	0.28	0.47	0.66	0.48
	6	0.28	0.47	0.79	0.64
EB 15mm & 1/2"	1	0.10	0.10	0.10	-
	2	0.14	0.14	0.14	-
	3	0.19	0.22	0.22	-
	4	0.25	0.35	0.38	0.16
	5	0.28	0.47	0.66	0.48
	6	0.32	0.57	1.01	0.68
EB 3/4"	1	0.10	0.10	0.10	-
	2	0.14	0.14	0.14	-
	3	0.19	0.22	0.22	-
	4	0.25	0.35	0.38	0.16
	5	0.28	0.47	0.66	0.48
	6	0.35	0.66	1.50	0.80
EB 1/2" ASP/SSP	-	-	1.40	2.50	-
EB 3/4" ASP/SSP	-	-	1.40	4.50	-
EB 1" ASP/SSP	-	-	1.40	5.00	0.92

Kv is flowrate in m³/h at a differential pressure of 1 bar

$$Kv = \frac{Q}{\sqrt{\Delta p}}$$

Q = Flowrate m³/h

Δp = Differential pressure bar

Automatic By-Pass Valve

The automatic by-pass valve is designed to maintain a minimum flow rate in heating systems fitted with thermostatic radiator valves.

FEATURES:

- Maintains optimum flow
- Automatic operation
- Set and forget
- Ensures quiet operation
- High quality
- Reliable

GETTING TECHNICAL

Model	Automatic By-Pass Valve
Connections	22mm
Setting range	0.05 to 0.5 Bar
Working pressure	16 bar
Working temp.	120°C Intermittent

AUTOMATIC BYPASS VALVE

Product	Part No.
22mm Angle auto bypass valve	07 02 020

APPLICATION

The automatic by-pass valve is designed to maintain a minimum flow rate in heating systems fitted with thermostatic radiator valves. When all the TRVs are open the by-pass valve remains closed, allowing the full boiler output to circulate around the heating system.

As TRVs sense that selected room temperatures are reached and start to close, the by-pass valve starts to open, maintaining optimum flow through the boiler and so eliminating possible damage to the boiler and pump. Installation of the by-pass valve will minimise noise often experienced when flow through the boiler decreases.

INSTALLATION

The by-pass should be installed between the flow and return with flow in the direction of the arrow.

If a higher capacity is required for large installations it is possible to install two or more valves in parallel.

SETTING

The valve can be manually adjusted from 0.05 Bar to 0.5 Bar. A setting of 0.2 – 0.3 Bar is sufficient for most common installations. If the differential pressure is too low or the by-pass flow is too high, the pressure setting should be increased. If the differential pressure is too high or the by-pass flow too low, the pressure setting should be decreased.



HTS3 Cylinder Thermostat

The HTS3 cylinder thermostat controls the domestic hot water temperature to suit your lifestyle and gives energy savings when set between the recommended 60°C to 65°C.

Positive On/Off for test purposes.

FEATURES:

- Easy fixing to all hot water cylinders
- Suited to all systems
- Tamper resistant
- Double insulated

HTS3 Cylinder Thermostat

Product	Part No.
HTS3	I3007

Wiring:

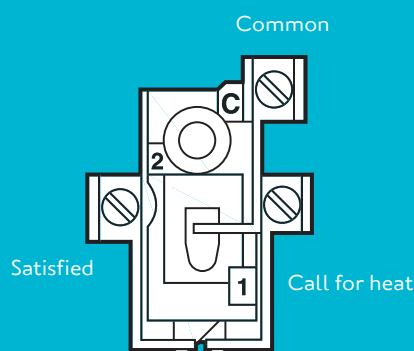

GETTING TECHNICAL

Model	HTS3
Sensing element	Bi-metal
Temperature range	50°C to 80°C
Switch rating	3 (I) A 230V a.c.
Switch type	S.P.D.T.
Differential	8°C approximately
Fixing	Plastic coated spring wire, hook and eye
Wiring	To comply with the current IET regulations

Digistat +CRF Wireless Cylinder Thermostat

Drayton's stylish wireless Digistat⁺C RF with tactile, audible & visual feedback. Featuring a familiar dial control with a digital display to show that the temperature has been set accurately every time.

- User adjustable Min/Max temperature setting
- Digital display situated above dial for ease of reading

The Digistat⁺C RF cylinder thermostat controls the domestic hot water temperature to suit your lifestyle and gives energy savings when set between the recommended 60°C to 65°C.

FEATURES:

- Conventional dial adjustment
Tactile dial
- 5°C setting steps
- Tactile & audible feedback via click of the dial
- Visual feedback via digital display
- Min/Max temperature setting
- Battery powered
- Digital display situated above dial for ease of reading



GETTING TECHNICAL

Model:	Digistat +CRF	SCR (receiver)
Power supply:	2 X 1.5V IEC LR6(AA) alkaline batteries	230V a.c. 50Hz
Switch type and rating:	N/A	SPDT (voltage free) 2(I)A 230V a.c. or 24V a.c./d.c
Wiring:	Designed for fixed wiring only, to comply with current IET wiring regulations (BS7671).	Ø 0.5mm ² 2 core cable between sensor and thermostat
Mounting:	Thermostat: Suitable for surface or conduit box mounting Sensor: Direct mounting onto cylinder	Industry standard wall plate
Battery life:	2 years typical	N/A
Ambient temperature:	Operating 0°C to 50°C / Storage - 20°C to 55°C	
Ambient humidity (non condensing):	Operating 25% to 90% / Storage 15% to 95%	
Temperature range:	40°C to 70°C	
Control Accuracy:	+0/-8°C	
Control Algorithm:	On / Off	
Temperature resolution:	5°C	
Ball pressure test:	75°C	
Pollution situation:	Degree 2	
Protection level:	IP30	
Pollution Class:	2	
Software Class:	A	
Radio frequency:	433 MHz	
Radio Signal Range:	30m typically. The range may be affected by the composition / density and number of walls between the thermostat and receiver.	
Relevant EC directives:	2006/95/EC Low Voltage Directive 2004/108/EC Electromagnetic Compatibility Directive 1999/5/EC R&TTE Directive - 2013/56/EU Battery Directive 2011/65/EU RoHS Directive	
Applied standards:	EN60730-1; EN60730-2-9 EN 300 220-2; EN 301 489-3	

DIGISTAT⁺C RF

Product	Part No.
Digistat ⁺ C RF cylinder thermostat & SCR & sensor	I3616
Digistat ⁺ C SCR receiver spare	22598
Digistat ⁺ C RF transmitter spare	I3618
Digistat ⁺ C RF sensor spare	I3619

Wiring:

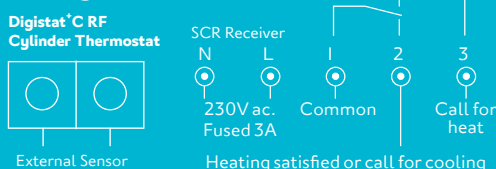

MiStat RF

Wireless Cylinder Thermostat

The MiStat digital wireless cylinder thermostat is pre-bound making installation simple even when meeting the requirements of Part P regulations.

FEATURES:

- Easitext on-screen step-by-step programming guide
- Universally recognised buttons and symbols
- On/Off algorithm
- Ideal for meeting Part P regulations
- Quick and easy installation – no wiring
- Pre-bound connection – devices already paired
- Signal strength indicator ensuring correct positioning
- 868MHz frequency - bi-directional
- 5°C setting steps
- +hr (Boost), giving 1, 2 or 3 hours
- Large backlit screen
- Battery powered
- Min/Max temperature setting

Wiring - SCR Receiver:

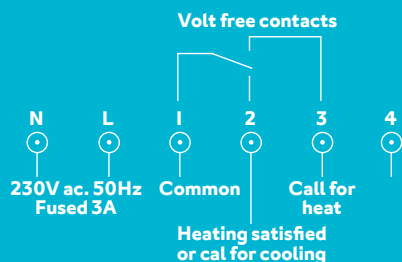

MiStat RF

Product	Part No.
MiStat RF Cylinder Thermostat + receiver & sensor	MCII0C9K0900
MiStat Cylinder Thermostat	MCII0C0S0900
MiStat Receiver	MRIII0S0900
MiStat Sensor	MCII0S0S0900

MiStat cylinder thermostats are also available as part of MiTime RF Packs offering complete control solutions – See page 28 for details



GETTING TECHNICAL

Model:	MiStatC	MiStatR (receiver)
Power supply:	2 X 1.5V IEC LR6(AA) alkaline batteries	230V a.c. 50Hz
Switch type & rating:	N/A	SPDT (voltage free) 2(1)A 230V a.c. or 24V a.c./d.c
Wiring:	Designed for fixed wiring only, to comply with current IET wiring regulations (BS7671).	Ø 0.5mm ² 2 core cable between sensor and thermostat
Mounting:	Thermostat: Suitable for surface or conduit box mounting Sensor: Direct mounting onto cylinder	Industry standard wall plate
Battery life:	2 years typical	N/A
Ambient temperature:	Operating 0°C to 50°C / Storage – 20°C to 55°C	
Ambient humidity (non condensing):	Operating 25% to 90% / Storage 15% to 95%	
Temperature range:	40°C to 70°C	
Control Accuracy:	+0/-8°C	
Control Algorithm:	On / Off	
Temperature resolution:	5°C	
Ball pressure test:	75°C	
Pollution situation:	Degree 2	
Protection level:	IP30	
Pollution Class:	2	
Software Class:	A	
Radio frequency:	868.3 MHz Bi Directional	
Radio Signal Range:	30m typically. The range may be affected by the composition / density and number of walls between the thermostat and receiver.	
Relevant EC directives:	2006/95/EC Low Voltage Directive 2004/108/EC Electromagnetic Compatibility Directive 1999/5/EC R&TTE Directive 2013/56/EU Battery Directive 2011/65/EU RoHS Directive	
Applied standards:	EN60730-1; EN60730-2-9 EN 300 220-2; EN 301 489-3	

PTSI

Pipe Thermostats

The PTSI Pipe Thermostat can be used in domestic or commercial installations for applications such as high or low limit.

It is typically used in conjunction with the Drayton RTS3 Air Frost Thermostat*, to provide two stage frost protection for boilers and exposed pipework.

FEATURES:

- Frost protection solution when used in conjunction with the RTS3 air frost thermostat
- Changeover contacts
- Lockable setting knob
- High or low limit applications
- Conduit adaptor/gland seal
- Concealed cover fixing screw

PTSI

Product	Part No.
PTSI	03 01 260

GETTING TECHNICAL

Model	PTSI
Setting range	20°C to 90°C
Ambient temperature	-35°C to 120°C
Switching differential	8k
Sensitivity	1k/min
Switch type	SPDT (volt free)
Switch rating	15(2.5)A 230V a.c.
Sensing element	liquid
Knob locking device	Supplied
Fixing wire	Supplied
Enclosure protection rating	IP40

* SEE PAGE 12 FOR FROST THERMOSTAT

Drayton

by Schneider Electric



Wiring:

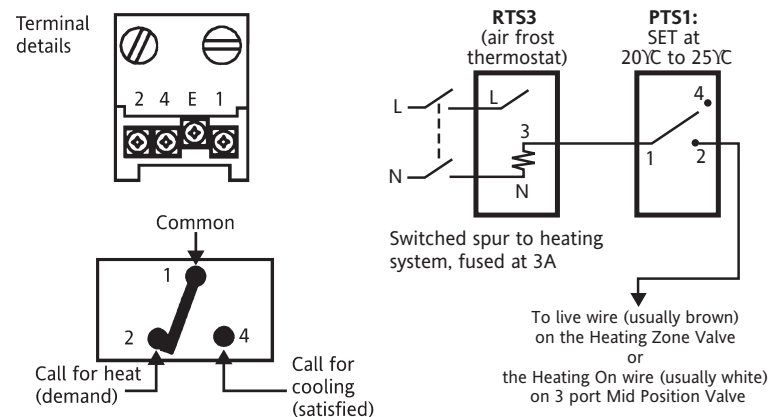

For boiler frost protection use PTSI in conjunction with RTS3

Tapstat Cylinder Controls

Self-acting tapstats control domestic hot water temperatures on gravity or pumped primary systems preventing scalding and fuel wastage.

FEATURES:

- High quality
- Self acting (non electric)
- Range limiting stops
- Remote sensor with 2m capillary
- Compression fittings for copper pipe
- Simple to install



GETTING TECHNICAL

Model	Tapstat
Max. static pressure	147 psi (10 bar)
Max. primary flow temperature	100°C continuous 120°C intermittent
Max. differential pressure*	15mm 2 way 59 psi (4 bar) 15mm 3 way 29 psi (2 bar) 28mm gravity 7 psi (0.5 bar)
KV value (fully open)	15mm 2 way 1.1 15mm 3 way 1.1 28mm gravity 4.6
Setting range	32°C to 72°C

* The differential pressures stated are maximum limits. It is not recommended that Tapstats are used at pressures above 8.8 psi (0.6 bar) as noise may be experienced in the system.

INSTALLATION:

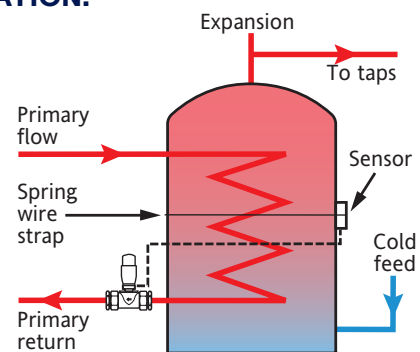

The gravity tapstat may be fitted in the primary flow line if preferred

Control Packs



Biflo Control Packs

Part No.	Programmer	Room Stat	Cylinder Stat	Valve	Wiring Centre
PBBE66	LP24I	RTSI	HTS3	22mm Mid Position*	LWCI
PBBE66S	LP24ISi	RTSI	HTS3	22mm Mid Position	LWCI
PBBE669S	LP24ISi	RTS9	HTS3	22mm Mid Position	LWCI
PBBE68	LP24I	RTSI	HTS3	22mm Mid Position*	LWC3
PBBE86	LP522	RTSI	HTS3	22mm Mid Position*	LWCI
PBBE86S	LP522Si	RTSI	HTS3	22mm Mid Position	LWCI
PBBE869S	LP522Si	RTS9	HTS3	22mm Mid Position	LWCI
PBBE88	LP522	RTSI	HTS3	22mm Mid Position*	LWC3
PBBE96	LP722	RTSI	HTS3	22mm Mid Position*	LWCI
PBBE969S	LP722Si	RTS9	HTS3	22mm Mid Position	LWCI
PBBE98	LP722	RTSI	HTS3	22mm Mid Position*	LWC3
SMBE362	SM2	RTSI	HTS3	22mm Mid Position	LWCI
SMBE382	SM2	RTSI	HTS3	22mm Mid Position	LWC3



Twinzone Control Packs

Part No.	Programmer	Room Stat	Cylinder Stat	Valve	Wiring Centre
PBTE66	LP24I	RTSI	HTS3	2 x 22mm 2-Port*	LWCI
PBTE68	LP24I	RTSI	HTS3	2 x 22mm 2-Port*	LWC3
PBTE86	LP522	RTSI	HTS3	2 x 22mm 2-Port*	LWCI
PBTE88	LP522	RTSI	HTS3	2 x 22mm 2-Port*	LWC3
PBTE96	LP722	RTSI	HTS3	2 x 22mm 2-Port*	LWCI
PBTE98	LP722	RTSI	HTS3	2 x 22mm 2-Port*	LWC3
SMTE362	SM2	RTSI	HTS3	2 x 22mm 2-Port	LWCI

Further pack options including untimed versions are available on request. *For 28mm versions, add B to the end of the part number.

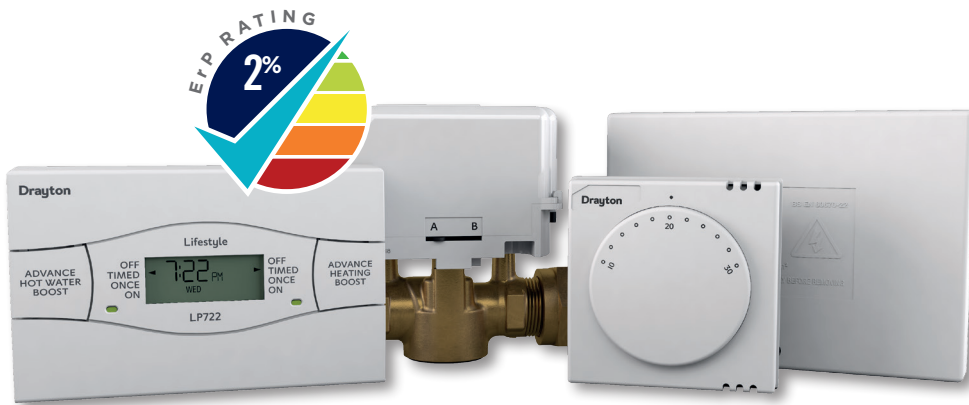

Unvented Control Packs

Part No.	Programmer	Room Stat	Cylinder Stat	Valve	Wiring Centre
UWH62	LP24I	RTSI	-	22mm 2-Port*	LWCI
UWH72	LPII2	RTSI	-	22mm 2-Port*	LWCI
UWH82	LP522	RTSI	-	22mm 2-Port*	LWCI
UWH92	LP722	RTSI	-	22mm 2-Port*	LWCI



Frost Protection Pack

Part No.	Room Stat	Pipe Stat
FPPI	RTS3	PTS1

Combi Packs

Part No.	Timeswitch	Room Stat
COMIII4	LPIII	RTS4
COM7II4	LP7II	RTS4

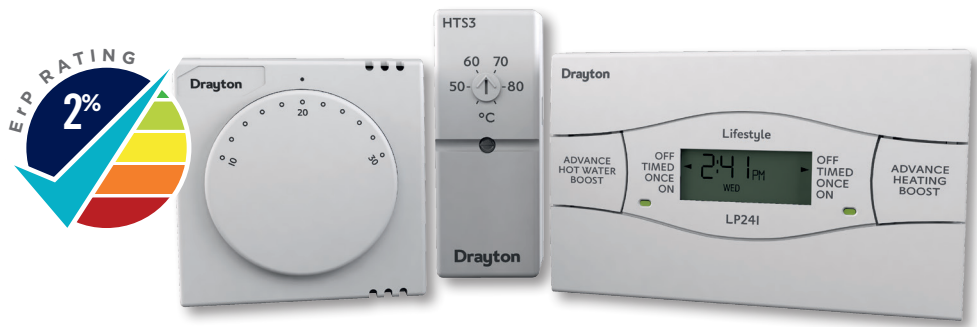

Pump Plan Packs

Part No.	Programmer	Room Stat	Cylinder Stat
PPII2	LPII2	RTSI	HTS3
PP24I	LP24I	RTSI	HTS3
PP522	LP522	RTSI	HTS3
PP722	LP722	RTSI	HTS3
PP24IS	LP24ISi	RTSI	HTS3

Further pack options including untimed versions are available on request. *For 28mm versions, add B to the end of the part number.

Underfloor Heating Controls Hydronic & Electric

Drayton offers a comprehensive range of underfloor heating controls. As an established market leader in heating controls coupled with the underfloor experience of our European sister company, Drayton underfloor heating controls possess extremely high standards of quality, flexibility, robustness and usability.

In line with our core expertise, the Drayton offering does not include pipe, insulation or energy sources but simply the controls to ensure that complete systems operate to their maximum efficiency.

Thermal Actuator

The next-generation TS+ Thermal Actuator is designed to fit on new compact manifolds and with improved water ingress protection.

FEATURES:

- Water and dust resistant to IP54 rating
- Can be mounted in any orientation - even upside down
- Provides visual confirmation of valve position
- Standard connection (M30 x 1.5mm) to manifolds
- Valves can be opened and closed by hand, great for commissioning and service
- Stylish and compact

THERMAL ACTUATOR

Product	Part No.
TS+ 5.1I/230	0493 I00I 1017
TS+ 6.1I/24V ac/dc	0492 I00II017

Drayton

by Schneider Electric

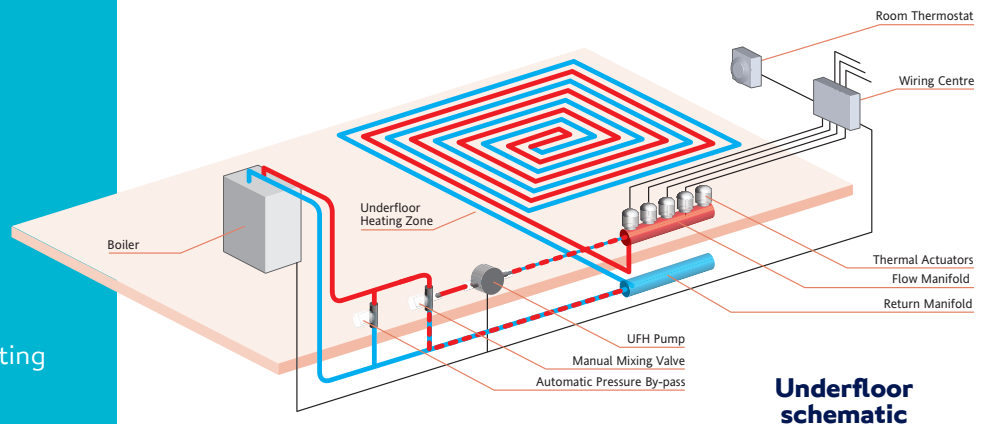

Underfloor schematic

Selecting the appropriate controls for an underfloor heating installation is of critical importance in maximising system comfort, energy efficiency and reliability. Drayton offers a one-stop shop for your controls needs, delivering a broad and differentiated range to enable you to get your controls selection right first time. **For further details see our specialist Underfloor Heating brochure available from customer services. Contact details on back cover.**

TS+ THERMAL ACTUATOR



TS Thermal Actuator is used in conjunction with room thermostats to control individual zones or rooms.

Thermostats & Connection Strips

The RTR-E 6124 room thermostat has a high control accuracy that can be used to control temperature in individual rooms and zones.

FEATURES:

- Automatic setback via external connection strip EVU 230 PL
- Bi-metal thermostat with thermal feedback and high precision
- Distinct connections and large connecting space for quick and easy installation
- Temperature limiting and locking under setting dial

The EV wired connection strips link room thermostats to the thermal actuators allowing independent temperature control of each zone.

FEATURES:

- 6-zone connecting strip EV 230 PL
- Wall mounting on DIN rail
- Easy to connect without screwdriver
- Dimensions: 305 x 90 x 60mm
- LED mains indicator
- Pump logic and protection

FEATURES:

As EV 230 PL with the following additional features

- 7-day programming of up to 6 independent zones
- Backlit LED display
- 5 preset programs
- Holiday function
- For use with room thermostats with set-back function e.g RTR-E 6124

RTR-E 6124



EV 230 PL



EV-U 230 PL



THERMOSTATS & CONNECTION STRIPS

Product	Part No.
RTR-E 6124	III II02 5I I33
EV 230 PL	0I0I 24 I4I 533
EV-U 230 PL	0I0I 22 I4I 533

Instat 868-r Range Wireless Thermostats

The wireless Instat+ 868-r is a programmable electronic clock room thermostat with a large LCD digital display which shows actual temperature and time.

FEATURES:

- Wireless connectivity avoids the need to re-decorate and provides flexibility on mounting position
- Energy-saving optimum start feature
- Easy to use with only 4 buttons
- Automatic address allocation to create wireless link effortlessly
- With real-time clock and automatic summer/winter time change

The Instat 868-rl wireless room thermostat can be used to control temperature in individual rooms and zones.

FEATURES:

- With setback function (-4K or -2K)
- Selector switch for permanent comfort, permanent setback, automatic function or off
- LED indicating learning mode and low battery strength
- Tamperproof with temperature limiting and temperature locking facility

WIRELESS THERMOSTATS

Product	Part No.
Instat+ 868-r	0536 2I 296 033
Instat 868-rl	0536 I0 29I 933

For further details request our specialist Underfloor Heating brochure, from our customer services department. Contact details on back cover.

Instat+ 868-r Wireless Programmable Room Thermostat



Instat 868-rl Wireless Room Thermostat



The Instat 868 wireless system provides a cost effective solution to the problems encountered during the installation of standard wired comfort controls.

CONSIDER THE BENEFITS OF A WIRELESS SYSTEM:

- No carpets and floor-boards to lift
- No damage to wall coverings
- No unsightly surface wiring
- Positioning no longer restricted to areas accessible by cable runs
- No brick or plaster work to chase out
- No damage to fabrics and furnishings in the process

Instat 868-a Range Wireless Connection Strips

The Instat wireless connection strips link room thermostats to the thermal actuators using proven 868 MHz wireless technology and are designed to work seamlessly with the 868-r and 868-rl wireless thermostats. This facilitates independent temperature control of each zone.

FEATURES:

- 4 or 6 channel receiver device for Instat 868-r and Instat 868-rl room thermostats
- Pump logic and protection (one output used)
- LED indicator for each channel

FEATURES:

- Instat 868-a8U 8 channel programmable receiver with clock
- For independent timed control of up to 8 zones using Instat 868-rl room thermostats
- Pump logic and protection (one output used)
- Backlit display
- Holiday function
- Up to 6 time/temp pairs per day

FEATURES:

- Receivers for Instat 868-rl transmitters and Instat+ 868-r
- LED to indicate malfunction / loss of signal
- Emergency operation in case of malfunction
- Reverse function for cooling instead of heating
- Reset button
- Single channel receiver

Instat 868-a4



Instat 868-a6



Instat 868-a8U



Instat 868-al



WIRELESS CONTROLS

Product	Part No.
Instat 868-a4	0536 40 140 033
Instat 868-a6	0536 60 140 033
Instat 868-a8U	0536 80 140 033
Instat 868-rl	0536 10 291 933
Instat 868-al	0536 30 140 002

MSV Manifold Hydronic Control Pack

The Drayton MSV Manifold and KRS-B Pump and Flow Pack provides the installer with a complete solution for underfloor heating. The components are also available individually. Please see the Drayton Underfloor Heating brochure for detailed information and part numbers.

- MSV Manifolds
- MSV Manifold Components
- KRS-B Pump and Flow Control Pack

MANIFOLD FEATURES:

- Compact design
- Corrosion resistant due to high quality MS63 brass
- The manifold can be sized according to the complexity of the system
- Supplied with air vents and fill cocks, shut-off ball valves, valves in each return port, and restrictors in each flow port

BENEFITS:

- Select individual components or complete solutions.
- Easy to install and commission.
- High-quality reliable products with full warranty and service support.

Drayton

by Schneider Electric

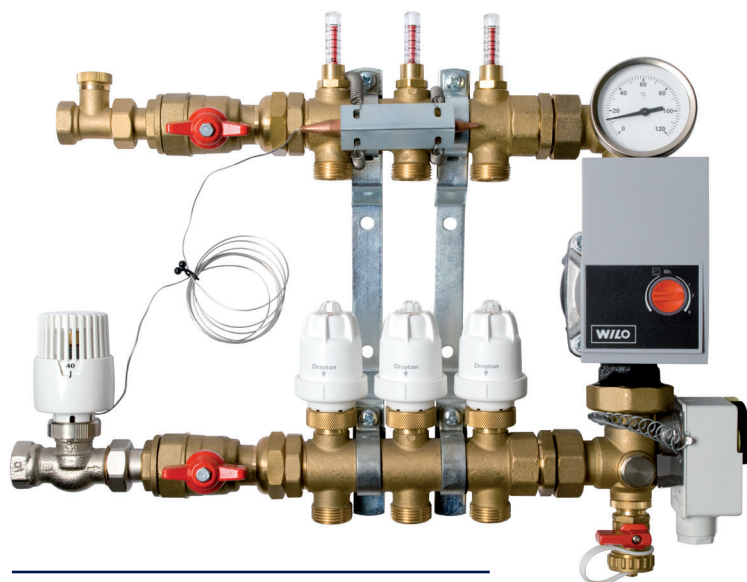

The complete manifold with pump and flow controls



DFM flow indicator

HYDRONIC CONTROLS

	Description
Manifolds	Brass manifolds available in multiple pre-assembled configurations or as modular components.
Flow Controllers	Flow controllers available as individual components or as packs with added mixing valve, high-limit thermostat and bypass valve
Pump Packs	A complete pack for flow temperature control containing circulation pump, flow control, high-limit thermostat, mixing valve and all connecting parts

Digistat

+3F/+3L

Electric Underfloor Heating Controls

GETTING TECHNICAL

Model	Digistat+3F	Digistat+3L
Relay output	1 change-over (voltage free)	
Switching current	Max. 16 (4) A	
Mode of regulation	proportional controller (PWM)	
PWM cyclus time	10 or 25 min.	
Connection	via screw-type terminals	
Timing resolution	1 minute	
Temperature resolution	0.1°C	
Pollution situation	Degree 2	
Protection level	IP30	
Wiring:	Designed for fixed wiring only, to comply with I.E.T. wiring regulations	

PROGRAMMABLE THERMOSTATS

Product	Part No.
Digistat+3F	22195
Digistat+3L	22196



Floor Temperature Controller



Room Temperature Controller with floor temperature limiter

VARIATIONS

Model	Digistat+3F	Digistat+3L	
Part No.	22195	22196	
Temperature Setting Range	Floor temperature 10 to 40°C	Room temp. 7 to 32°C	Floor temp. 10 to 40°C
Power Supply	Mains; 230V a.c.		
Remote sensor	Included		

Easy 3L/3F

Programmable Thermostat

Drayton presents a simple-to-use programmable control with traditional analogue clock face.

FEATURES:

- For Electric Underfloor Heating
- Two models available: Floor temperature controller and room temperature controller with floor limiter
- Day and night temperatures independently selectable
- 5 operational modes via setting dial for Day / Night / Automatic / Frost protection / Off
- With 24 hour clock
- With remote sensor for measuring the floor temperature (if sensor fails, emergency operation 30 % heating)
- Hinged cover

PROGRAMMABLE THERMOSTAT

Product	Part No.
Easy 3L	517 2707 51 II2
Easy 3F	517 2705 51 II2

GETTING TECHNICAL

Model	Easy 3L	Easy 3F
Part No.	517 2707 51 II2	517 2705 51 II2
Temperature setting range	Room temperature 5 to 30°C	1 to 5 Numerical scale (10 to 50°C)
Set-back temperature	5 to 30°C (under cover)	1 to 5 Numerical scale (10 to 50°C)
Frost protection	5°C fixed	Setting under cover 10°C (fixed)
Contact (Relay)	1 change-over, voltage-free	1 change over, voltage free
Operating voltage	230V a.c.	230V a.c.
Switching current	10 mA to 16 A $\cos \varphi = 1$ / max. 4 A $\cos \varphi = 0.6$ / max. 10 thermal actuators	10 mA to 16 A $\cos \varphi = 1$ / max. 4 A $\cos \varphi = 0.6$
Mode of regulation	Proportional controller (quasi-continuous due to PWM) or On-Off	
Proportional band	~ 1.5 K	
Cycle period	Adjustable, 10 or 25 minutes	
Indicator lamps	Call for heat / Set-Back	Call for heat / Set-Back
Timer: Switching time setting	Every 15 min daily timer / every 1 h weekly timer	
Power reserve	~ 100 h	~ 100 h
Protection class of housing	IP 30 / insulated	IP 30 / insulated
Dimensions	160 x 80 x 36 mm	160 x 80 x 36 mm

Drayton

by Schneider Electric



Wiring:

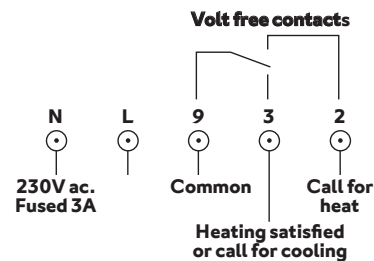

Electric Underfloor Heating

Non-programmable Thermostat

FEATURES:

- Electronic temperature controller with remote sensor
- Wall mounted
- Range limitation setting under dial
- On / Off switch

NON PROGRAMMABLE THERMOSTAT

Product	Part No.
FR-E 525 3I	515 1107 51 I33

Wiring:



GETTING TECHNICAL

Model	FR-E 525 3I / 30°C
Part No.	515 1107 51 I33
Temperature range	5 to 30°C
Contact (Relay)	Not voltage-free / normally open contact
Operating voltage	230V a.c.
Switching current	16 (4) A
Hysteresis	~1K
Switch and Indicator lamp	LED indicator - Mains on/off and call for heat
Protection class of housing	IP30 double insulated
Remote sensor	Included
Dimensions	75 x 75 x 25.5 mm

Wiring Centres

Wiring centres provide a safe and convenient method of system wiring. All controls can be neatly connected making operational testing a simple task.

FEATURES:

- Easy to use
- Simplifies wiring and circuit testing
- Suited to all popular heating systems
- A safe means of connection
- Large terminals
- Easy access
- Complies with BS60670-22

WIRING CENTRES

Product	Part No.
LWC1 Wiring Centre	28001
LWC3 Junction Box	28003

GETTING TECHNICAL

Model	LWC1	LWC3
12 way junction box	-	✓
16 way wiring centre	✓	-
Manufactured in flame-retardant plastic	✓	✓
Cable clamps supplied	✓	✓
Top or bottom cable entry bays	-	✓
Large diameter wiring terminals	✓	✓
Wiring links provided to suit most systems	✓	-
Cable identification labels included – with full installation instructions	✓	-



DIMENSIONS:

LWC1

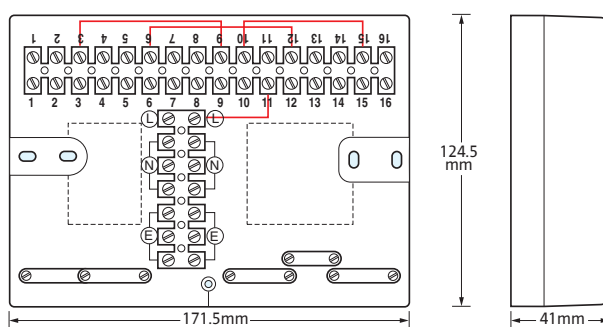

LWC3

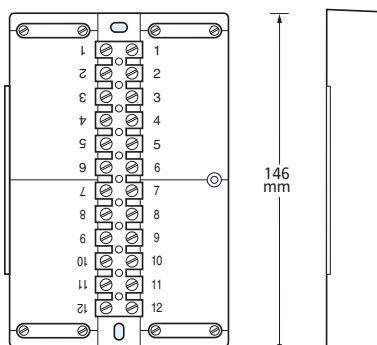

Drain Easy Kit

A valuable time-saving kit to avoid system draining for repairs and replacements on open vented 'wet' central heating systems.

DRAIN EASY KIT

The Drayton Drain Easy kit comprises two durable rubber plugs, a tie and a radiator bleed key.

It is designed to facilitate removal of valves, repair of leaks etc. on an open vented wet central heating system without draining down, consequent loss of inhibitor, and risk of major air locks during refilling. It can only be used where the header (feed and expansion) tank is no more than 30ft (9 metres) above the lowest point in the system and only one break in the system is being made at a time.

The most important benefit of using the Drain Easy kit is to allow easy replacement of standard radiator valves with energy-saving TRVs. Thermostatic radiator valves such as the Drayton TRV4 offer substantial reductions in running costs over normal valves, coupled with improved comfort as room temperatures may be set individually.

It is also a valuable emergency kit which will allow various repair and maintenance jobs such as the replacement of failed pipes, valves, radiators etc. to be undertaken quickly and easily.

DRAIN EASY KIT

Product	Part No.
Drain Easy Kit	07 01 165



FITTING

The specially-shaped Drain Easy plugs are fitted into the cold feed and the expansion pipe of the feed and expansion tank.

After releasing some inherent pressure in the system with the bleed key supplied, and building up a vacuum by allowing water to flow for about 1 minute, any single item such as a pump, valve or radiator may be removed without further loss of system water/inhibitor.

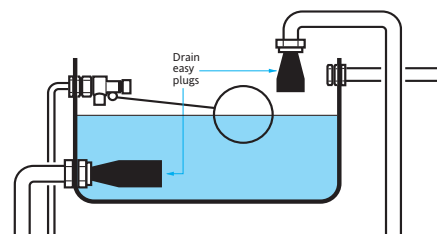

SPECIFICATION

Kit contents

Two Rubber male plugs, radiator bleed key, 1m tiecord, full instructions.

Materials

Plugs: Ethylene propylene
Bleed key: Brass stamping

Limitations

- Suitable for 15mm and 22mm pipework.
- Not to be used on direct, unvented or primatic systems or auto-vented systems.
- Not to be used on systems with a header tank more than 30ft (9 metres) above the systems lowest point.
- No lubricating oils to be applied.
- Only one section of pipework can be disconnected at a time e.g. No three-way valves – one two-way disconnection only.

Décor Plate & Spacer Box

Drayton

by Schneider Electric

DÉCOR PLATE FEATURES:

- Simple to install
- Reduces the need for redecoration
- Covers the spaces left by the majority of competitor models
- Two-part construction allows fixings to be invisible
- Can be used in conjunction with "Spacer Box"

SPACER BOX FEATURES:

- Simple to install
- Suitable for LP, Tempus & SM Range of clocks
- Suitable for single or double electrical wiring boxes
- Universal back plate fits directly onto using fixings provided
- Can be used in conjunction with "Décor Plate"



DÉCOR PLATE & SPACER BOX

Product	Part No.
Décor Plate and Spacer Box	28011
RTS Pattress	24022

DÉCOR PLATE

The decoration plate provides a simple and effective means to cover "bare patches" left in the décor when replacing other makes of time controls. It is designed with a two-part construction allowing all fixings to be invisible providing a clean and professional finish.

SPACER BOX

The Spacer Box provides a convenient way to house all wiring in installations where the existing programmer has been used as a wiring centre. The Spacer Box is also effective in installations where tiling is to be fitted around the time control allowing removal of the control to still be achieved.

Programmer Compatibility Guide

THE QUICK AND EASY WAY TO COMPARE, UPGRADE AND REPLACE EXISTING PROGRAMMERS

Drayton manufacture electronic and electro-mechanical programmers and timeswitches suitable for replacing most makes found in use today. Our expertise in product development has produced a range of high quality controls offering ease of use and long term reliability for which we are renowned.

Before removing an existing programmer, it is essential to note wire colours and terminal positions and to ensure the new backplate is wired in accordance with these conversion charts.

Check that a **3 amp** fuse is fitted before mains power is restored to the system, this will avoid costly damage to electronic components should a system fault occur.

MULTI CHANNEL PROGRAMMER TERMINAL COMPARISONS

Make	Model	Earth	Neutral	Live	Ch1 on	Ch2 on	Ch3 on	Ch4 on
------	-------	-------	---------	------	--------	--------	--------	--------

CURRENT MODELS

Drayton	miGenie Wish 3		N	L	I	2	3	4
Drayton	MiTime MT742R, MiTime RF Pack 4 & Pack 5		N	L	I	2	3	4

COMPETITORS' MODELS

Horstmann	H47XL	E	N	L	I	3	4	6
Horstmann	H37VXL, H37XL	E	N	L	I	3	5	
Sunvic	Select 307 XLS		N	L	3	4	5	

PROGRAMMER TERMINAL COMPARISONS

Make	Model	Earth	Neutral	Live	H/W off	C/H off	H/W on	C/H on
------	-------	-------	---------	------	---------	---------	--------	--------

CURRENT MODELS

Drayton	miGenie Wish 2		N	L	I	2	3	4
Drayton	MiTime MT721R, MiTime RF Pack 2 & Pack 3		N	L	I	2	3	4
Drayton Lifestyle	LPII2, LP24I, LP522, LP722, LP24ISi, LP522Si, LP722Si		N	L	I	2	3	4
Drayton	SM2		N	L	I	2	3	4

DISCONTINUED / COMPETITORS' MODELS

Drayton	Tempus 3, 4, 6, 7 (Old models), Tempus 6, 7		N	L	I	2	3	4
Switchmaster	400, 600 (No connection to terminal 4 on 600)		N	L		4	3	1
Switchmaster	805, 900, 900i		N	L	4	2	3	1
ACL	MP (Towerchron)			I				
ACL	FP (Towerchron)		2	I	8	11	6	10
British Gas	EMP2, UPI, UP2		N	L	I	2	3	4
Danfoss	CP15, CP715, FP15, FP715 (Mk18), CP715 Si, FP715 Si		N	L	I	2	3	4
	3020P, 3060	E	7	6			4	2
	4033 (link I-6)	E	7	6	5	3	4	2
	102, 102E, 102E5, 102E7, (link 6-3)	E	5	6			1	2
	701 (link L-5 and 5-6)	E	N	L			3	1
	702 (link L-5 and 5-6)	E	N	L	4	2	3	1
	922, 972 (link L-2 and 2-5)	E	N	L	I	4	3	6
	SET2, SET2E, SET3E, SET3M, FP975, SET5 (link L-2 and 2-5)	E	N	L	3	6	1	4
Honeywell	ST 699/799 (link L-5 and 5-8)		N	L	7	4	6	3
	ST 6200, ST 6300, ST 6400, ST 6450, ST6400S, ST9400A/C, ST9400S, ST9500C, Y9420H RF ² Pack 2, Y9420S RF ² Pack 3, Y9520Z RF ² Pack 5		N	L	I	2	3	4
	ST 7100 (link L-3 and 3-6)		N	L	7	4	8	5
Horstmann	525, 527, 425 Diadem, H21, H27, H121, Tiara, (link L-2 and 2-5), Channelplus H21XL, H27XL, H27ZXL	E	N	L	3	6	1	4
	Centaur Plus C21, C27, CI21 & CI27		N	L	I	2	3	4
Myson	Microtimer (link L-5 and 5-8)		N	L	7	4	6	3
	MEP2C		N	L	I	2	3	4
Potterton Myson	ALL EP2000's, EP3000's, EP6000's, (link L-5 and N-N)		N	L	I	2	3	4
	Mini Minder		N	L	I	2	3	4
Siemens / Landis & Staefa	RWB2, RWB2E, 20, 40, 102, 200, 252 & 270, RWB9, RWB29		N	L	I	2	3	4
Sunvic	Select 207, SunPro2000		N	L	I	2	3	4
	SP50, SPI00 (link L-3)		N	L	I	4	2	5
Salus	EP200, SP220		N	L	I	2	3	4
Grasslin Towerchron	DP 72, QE2		N	L	I	2	3	4
Sangamo	M5, (Link I-6)		N	L			1	8

Timeswitch Compatibility Guide

THE QUICK AND EASY WAY TO COMPARE, UPGRADE AND REPLACE EXISTING TIMESWITCHES

These tables show the wiring conversion necessary to replace an existing programmer.

MiTime and Lifestyle 'LP' models directly replace

former ACL-Lifestyle 'ILP/LP/LS' and Drayton Tempus programmers, the only models requiring wiring modifications are old Tempus 1/2 and LSII2 (remove link L to I on the backplate). Drayton can accept no liability for wiring errors at the time of installation, for any reason.

TIMESWITCH TERMINAL COMPARISONS

Make	Model	Earth	Neutral	Live	Com- mon	On	Off	Spare
CURRENT MODELS								
Drayton	miGenie Wish I		N	L	I	3	2	4
Drayton	MiTime MT7IIR, MiTime RF Pack I		N	L	I	3	2	4
Drayton Lifestyle	LP111, LP711, LP111Si, LP711Si		N	L	I	3	2	4
Drayton	SMI		N	L	I	3	2	4
DISCONTINUED / COMPETITORS' MODELS								
Drayton	Tempus 1 and 2		N	L	I	3	2	4
Drayton	Tempus 1 and 2 (Old models)		N	L	I	2	3	4
Switchmaster	300, 980		N	L	4	1		
ACL	TC (Towerchron)		2	I	4	7		
British Gas	EMT2, UT1, UT2		N	L	I	3	2	4
Danfoss	TS15, 75 (Mk18)	E	N	L	I	4	2	5/6
	TS715, TS715 Si		N	L	I	4	2	3
	TS975	E	N	L	5	4	6	1,2,3
	SET1, SETIE	E	N	L	5	4	6	
	SET4	E	N	L	5	4	6	
	I03, I03E, I03E5, I03E7	4	5	6	3	1		2
	911, 971	E	N	L	5	6	4	2
Honeywell	ST 6100A, ST 6100C, ST6100S, ST9100A/C, ST9100S, Y9120H RF² Pack 1, Y9120W RF² Pack 4		N	L	I	4	2	
	ST 7000B		N	L	I	2	3	4
Horstmann	Centaur SCI, SC7			L		3	2	
	Channelplus HI7XL, HIIXL	E	N	L		4	6	
	Centaur Plus CII, CI7, CI7-ZW		N	L	2	4	3	
	Emerald 423, Pearl Auto		N	L	2	4	3	
	517, Coronet, H11, H17	E	N	L	3	4		
Myson	Microtimer (link L-5 and 5-8)		E	N	L	5	4	6
	MEPIC		N	L	I	3	2	4
Potterton Myson	EP4000, 4001, 4002, 5002		N	L	5	4	2	
Siemens / Landis & Staefa	RWB3		N	L		4	3	
	RWB27, RWB30, RWB50, 100, 152, 170		N	L	2	4	3	
	RWB7	E	N	L	2	4	3	
Sunvic	Select I07, SunProI000		N	L	I	3	2	4
	SP20, SP35		N	L	3	5	4	5
Salus	EPI01, SPI20		N	L	4	3		
Grasslin Towerchron	QE1		N	L	2	4		
	T2001, T2001Q	E	N	L		7		
Sangamo	M6			E	4	6	3	1
Smiths	Centroller Mk1 & Mk2		N	L	3	2		
	Centroller 30		I	2		3/4		
	Centroller 300, 980		N	L	4	1		
Venner	Vennerette		N	L	LINE	LOAD		

Room Thermostat Compatibility Guide

Please note the list opposite of current Drayton models and the discontinued/competition models can be replaced by the Digistat⁺2 and ⁺3 (battery) product.

Digistat⁺2 and ⁺3 (battery) programmable room thermostats are battery operated and double insulated therefore neutral and earth connections are not required. Unused existing cables should be safely isolated.

Digistat⁺2 and ⁺3 (battery) can replace the existing basic or programmable room thermostats and where there is no room thermostat presently fitted would enhance the heating systems comfort and economy. Digistat⁺2 and ⁺3 can be used in conjunction with existing timeswitches and programmers.

When fitting the Digistat⁺2 and ⁺3 (battery) to an existing system the timeswitch/programmer controlling the central heating system should be set to constant ON position to allow the correct operation. Note the programmable thermostat controls both time and temperature of the heating system.

The information is a guide only.

Installation of the Digistat⁺ range should be carried out by a qualified electrician. Please refer to the wiring diagram shown in the Digistat⁺2 and ⁺3 (battery) installation instructions.

ROOM THERMOSTAT TERMINAL COMPARISONS							
Make	Model	Earth	Neutral	Live	Common	Satisfied	Demand
CURRENT MODELS							
Drayton	miGenie Wish I		N	L	I	2	3
	Digistat+, +1, +2 and +3 (Battery)				C	Off	On
	Digistat+2 and +3 (Mains)		N	L	C	Off	On
	RTS 1, 2		N		L		3
	RTS 4, 5 & 6, 9		N	L	I	2	3
DISCONTINUED / COMPETITORS' MODELS							
Drayton	Digistat I, 2, 3, 3i and 4				I	2	3
	RT/RTE		4		I	3	2
ACL Lifestyle	PT 271, 371		N	L	I	2	3
	OPT 170, PT 110, 170		N	L	4		3
Danfoss	TP2, 3, 4, 5, 5E, RT1				I	2	3
	TP 5000, RT51, RT52, TP5000 Si				B	A	C
	TP7000				I	3	2
	TP7001A				H	COM	H OFF HON
	TP7001M		N	L	H	COM	H OFF HON
	TP75				3	6	5
	TP75H				COM	OFF	ON
	RET-B				3	1	2
	TP7000M		N	L	I	3	2
	TP6000M				N	L	1
	RET M, MD				N	L	2
	TP75M, MA		N	L	I	2	4
	TP1		E	N		L	2
	RD3, RD3A		4		I		2
	RTC, RTM, RSR		E	N	3	2	1
	RMT 230		4		I	3	2
	R504				N		3
	RET 230, NL213		N		L	4	3
	TP5000M Si, TP5000MA Si		N	L	2	1	3
Honeywell	CM31, 37, 41, 51, 61, 67, CM721, CM727, CM901, CM907				A	C	B
	CT200, T6620, DT200, DT90E				A	C	B
	T6060/6160/6063/6360		2		I	4	3
Horstmann	C-Stat II-B, C-Stat I7-B				I	3	4
	C-Stat II-M, C-Stat I7-M		N	L	I	3	4
	AS2				I		2
	ASI		N	L	2		4
	Centuarstat I & 7		4		I	3	2
	HRT I		E	4	I		2
	HRT4-A		2		I		4
	HRT4-B				I		4
Myson	MPRT, MRTE				2		1
	MRT1		4		I		3
Potterton	PRT I		N		L		H
	PRT2 & 100 ST			N		TL	
	PRT 100 DT		N		TL	C	H
Siemens / Landis & Gyr / Landis & Staefa	REV II, I2				L		LI
	RAD I		E			I	3
	RAA02		N		I	Y3	Y2
Sunvic	TLX 1001 / 1005		N	L	COM	OFF	ON
	TLX 9000 series		4		I	2	3
	TLX 6501				I	3	2
	TLX 7501, TLX 1009				3	1	2
	TLX 2251				3		1
	TLX 2222, 2259, 2267		E	4	3		1
	TLX 2356				3	2	1
	TXL 3101, 5101		2		I		8
	TLX 4101, 4102				2	3	1
	TLX 5201, 5202		2		I	6	8
	TA 351		E	4	I	2	3
Salus	RT100				COM	NC	NO
	RT200, RT300, RT500, ST320, ST320PB, ST620, ST620B, 09IFL, 09IFLPB		N		L		SL
Tower	SS		E	4	I		2

WIRELESS ROOM THERMOSTAT TERMINAL COMPARISONS							
Make	Model	Earth	Neutral	Live	Common	Satisfied	Demand
CURRENT MODELS							
Drayton	miGenie Wish I		N	L	I	2	3
	MiStat MN110R and MP710R		N	L	I	2	3
	Digistat+RF, +IRF, +2RF and +3RF		N	L	I	2	3
DISCONTINUED / COMPETITORS' MODELS							
Drayton	Digistat RF1, RF2, RF3 and RF3i		N	L	I	2	3
Danfoss	RET B-RF, RT51-RF, TP4000-RF, TP5000-RF Si, TP7000-RF		N	L	2	4	3
Honeywell	Y6630D, DT92E, CM921, CM927		N	L	A	C	B
Horstmann	C-Stat II-ZW, C-Stat I7-ZW, AS2RF, HRT4-ZW		N	L	2	3	4
Myson	MPRT-RF		N	L	C		I
Siemens	RDH10RF, RDJ10RF, REV24RF		N	L	Lx	L2	LI
Sunvic	TLX RFPv		N	L	2	3	1
	TLX 1010 RF, TLX 1012 RF		N	L	COM	OFF	ON
Salus	RT300RF, RT500RF, RT500ROF, 09IFLRF, ST320RF, ST620RF, iT500		N	L	COM		NO

Principles of Intelligent Delayed Start

BENEFITS OF INTELLIGENT DELAYED START

- Can save in excess of 10% of heating fuel
- SAP and NHER rated
- Unique self-learning software that matches delay times to house and heating system characteristics
- Helps reduce harmful CO² emissions
- Adapts start up time to suit heating and building conditions
- No extra programming required

PRINCIPLE OF INTELLIGENT DELAYED START

The majority of people set their heating to come on one hour before they get up. This is usually long enough to ensure that the rooms are up to temperature, even in the coldest conditions.

During milder weather a full one hour preheat is probably not required. So in some cases, the boiler could be burning fuel unnecessarily for up to 1 hour.

The Intelligent Delayed Start feature saves this fuel wastage by measuring the room temperature when the heating is due to switch on. The unit then decides whether to switch on straight away, or delay the start for up to 1 hour. By using delayed start, savings in excess of 10% can be achieved without compromising comfort.

Available on Digistat⁺2, Digistat⁺2 RF, Digistat⁺3, Digistat⁺3 RF and Mi Series MP710R.

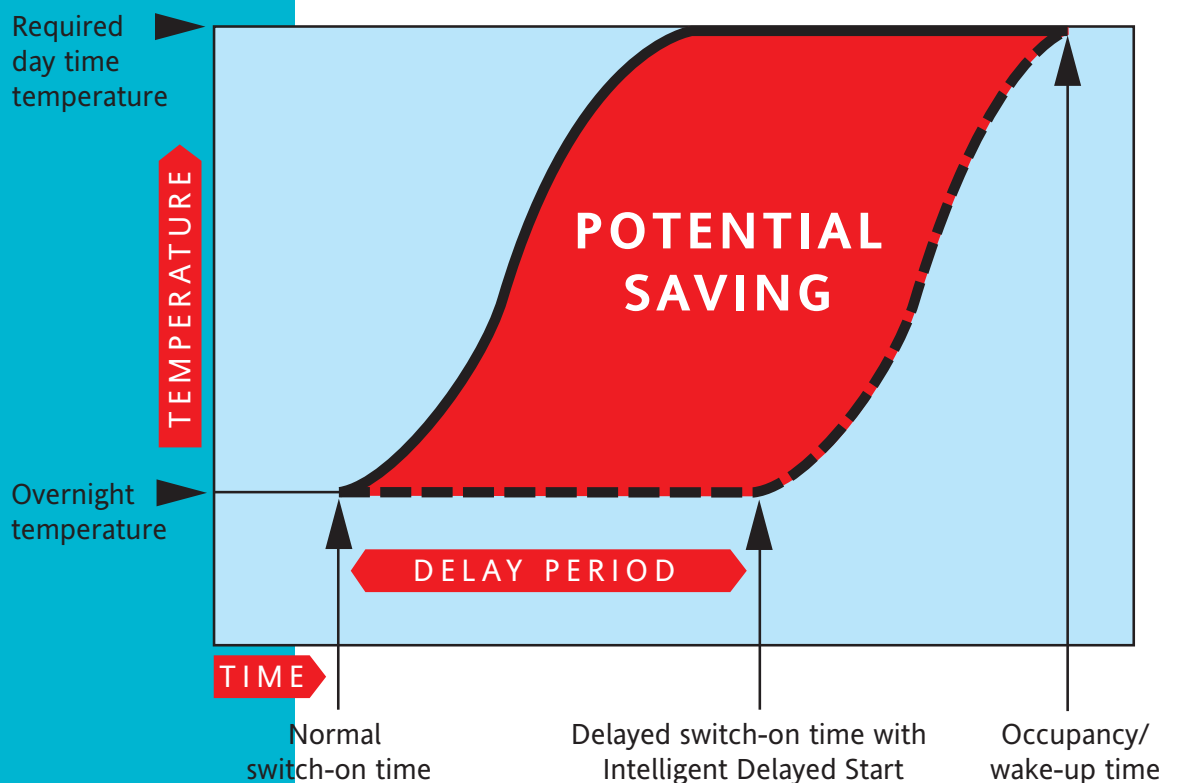

If a heating system is on for 8 hours per day, a 1 hour saving = 12.5%

Introduction to 2013 Building Regulations:

Part L

WHAT'S CHANGED AND HOW TO COMPLY

From the 6th April 2014, a revised version of Part L Building Regulations came into force. There have been some minor changes to the previous version, the recommended minimum requirements are:

1. The requirement for dwellings under 150m² to have at least two heating zones has now been removed. To provide zone control in such dwellings TRVs (Thermostatic Radiator Valves) should be provided on all radiators (except the room with the room thermostat) on new systems. It is also good practice to install TRVs when replacing a boiler in an existing system as it is convenient and timely to do this while the system is drained down.

2. The Domestic Building Services Compliance Guide now contains specific recommendations for minimum standards when only a part, or parts, of an existing system are being replaced, the following are considered good practice:

- i. Hot Water Cylinder - Install a boiler interlock and separate timing for space heating and hot water
- ii. Boiler - Fit individual radiator controls such as TRVs on all radiators except those in the room with a room thermostat
- iii. Radiator - Fit individual radiator controls such as TRVs on all radiators except those in the room with a room thermostat
- iv. New heating system – existing pipework retained - Minimum standard to fit individual radiator controls such as TRVs on all radiators except those in the room with a room thermostat

Example layouts for **new systems in dwellings up to 150m²** and for **replacement boilers in all dwellings** to ensure compliance.

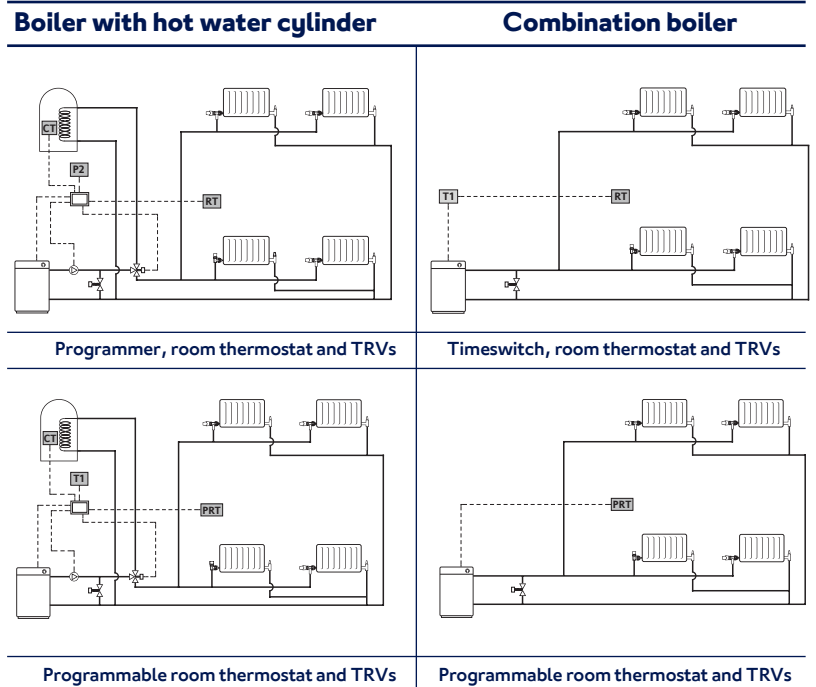

Example layouts for **new systems in dwellings over 150m²** to ensure compliance.

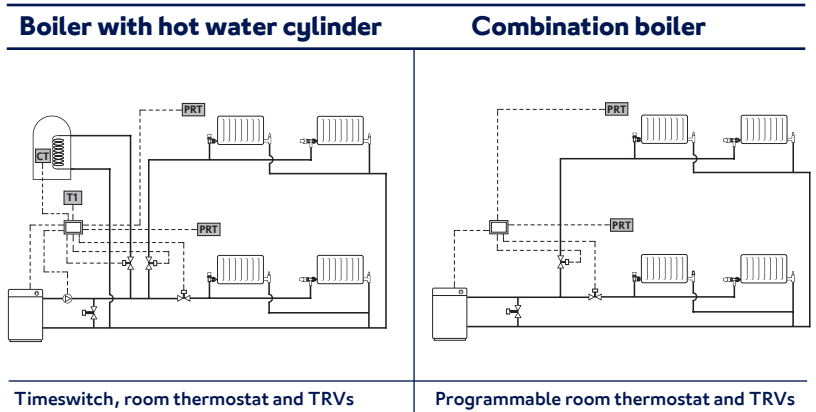

KEY TO SYMBOLS

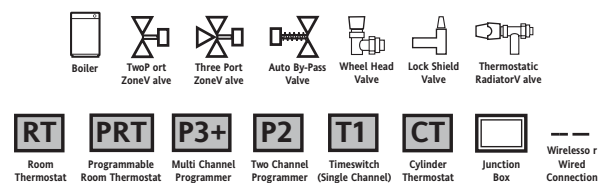

These are just a small number of example layouts for the different systems impacted by the changes in Part L. For more information and examples of other layouts please see www.beama.org.uk/heatingcontrols

Twinzone control systems

FOR FULLY PUMPED SYSTEMS

In a fully pumped zone system the boiler provides a common supply of heated water which is fed to the motorised valves by the pump. The two port valve on each circuit will open or close depending on demand from the thermostats – see table below.

Each valve controls the flow of heated water to the heating or hot water circuits independently. The boiler and pump will continue running whilst there is a demand from one or both thermostats. If both thermostats become satisfied the pump and boiler will switch off to save fuel.

Room Thermostat	Cylinder Thermostat	Valve Positions
Calling for heat	Calling for heat	Both valves open
Calling for heat	Satisfied	Heating valve open
Satisfied	Calling for heat	DHW valve open

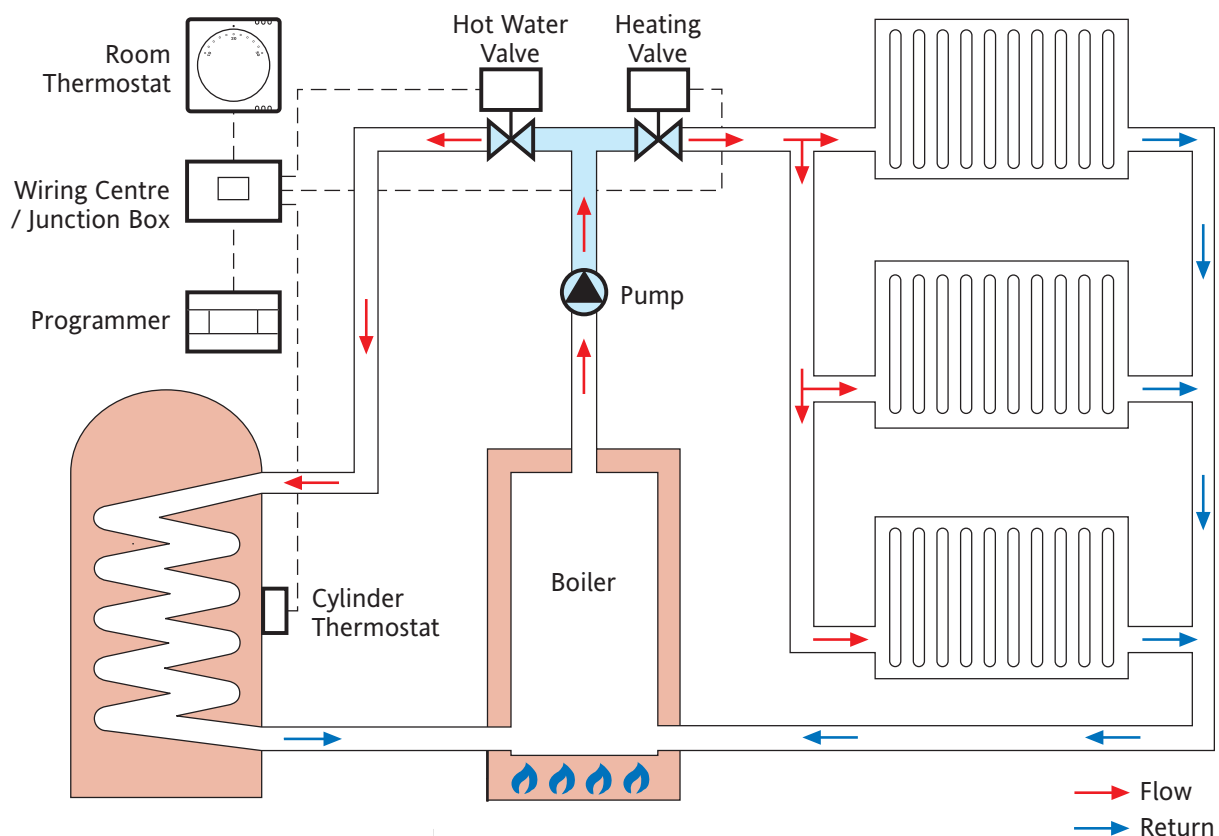

Twinzone Control Systems

WIRING DIAGRAMS FOR LWCI WIRING CENTRES

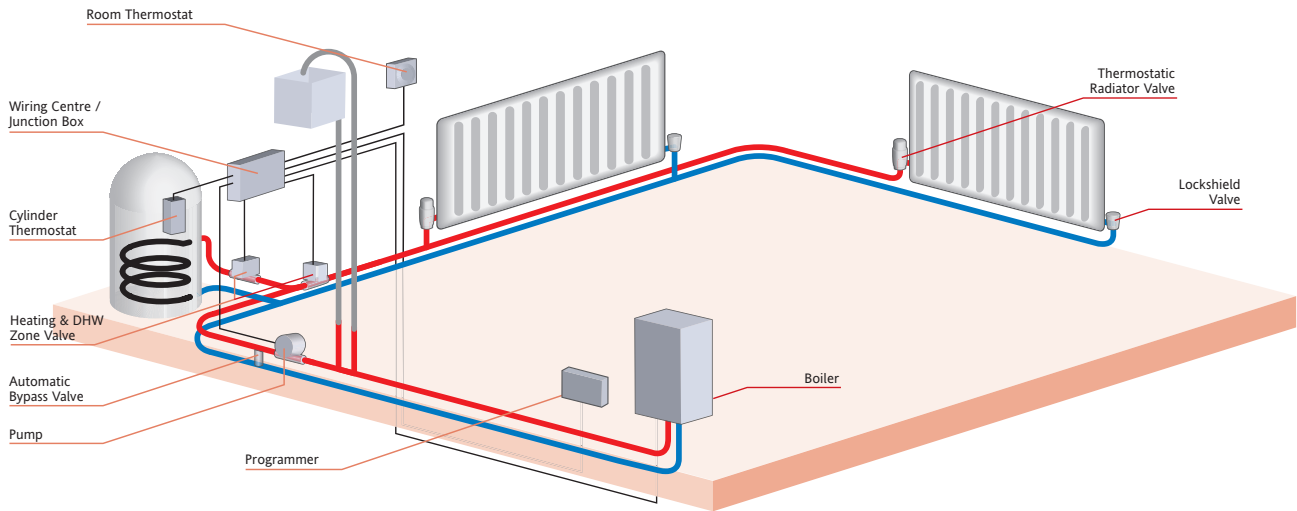

Room thermostat			Time Control			TRV	Wiring Centre	Cylinder Thermostat	Motorised Valve (x2)
Non-programmable	Hard wired	RTS	Timer	Electronic	Lifestyle LP	RT212	LWCI	HTS3	22mm mid position
		Combi-Stat		Mechanical	SM1	RT414	LWC3	Digistat* C RF	
		Digistat*	Programmer	Electronic	Lifestyle LP	TRV4			
Programmable	Hard wired	Easy							
		Digistat* Range							
		Wireless	Digistat* Range						

Wiring Information for Twinzone Control Systems with LWCI Wiring Centres

Wiring Centre - BASIC LINKS

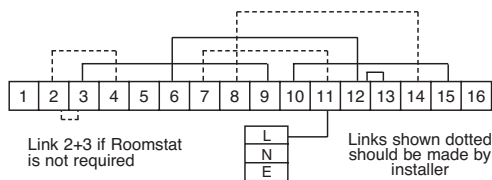

Pump

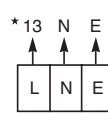

Boiler

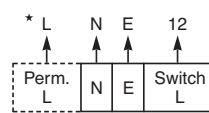

Room Thermostat

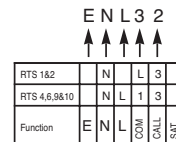

Cyl. Thermostat

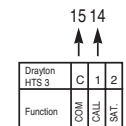

Programmer

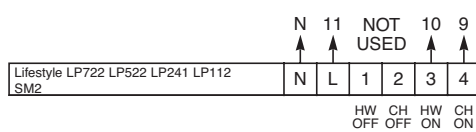

Mains Input - 230V a.c.

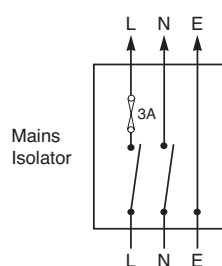

Motorised Valve

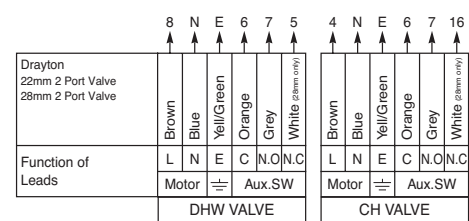

The white wire (28mm Valves) becomes live when the valve closes, it is not used and is wired to spare terminals for safe isolation.

*Refer to Boiler Handbook for wiring details of Pump Overrun boilers. Use boiler manufacturers instructions.

Connections: The numbers printed at the tip of each arrow represent the Wiring Centre Terminals to which those leads or terminals should be connected.

Twinzone Control Systems

WIRING DIAGRAMS FOR LWC3 JUNCTION BOXES

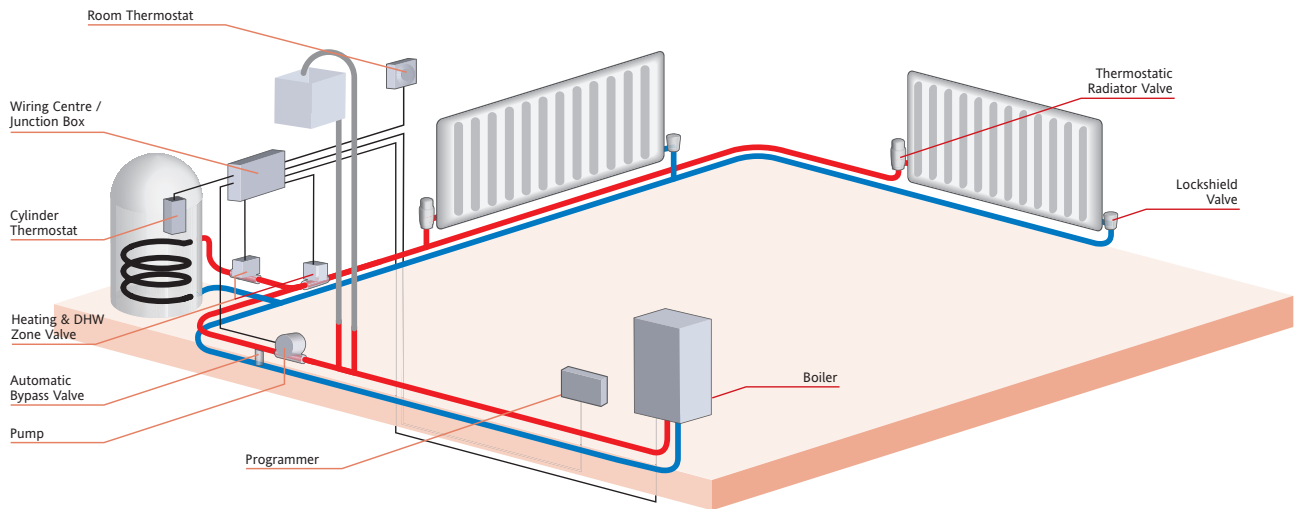

Room thermostat			Time Control			TRV	Wiring Centre	Cylinder Thermostat	Motorised Valve (x2)
Non-programmable	Hard wired	RTS	Timer	Electronic	Lifestyle LP	RT2I2	LWCI	HTS3	22mm mid position
		Combi-Stat		Mechanical	SMI	RT4I4	LWC3	Digistat* C RF	
		Digistat*	Programmer	Electronic	Lifestyle LP	TRV4			
	Wireless	Digistat*RF		Mechanical	SM2				
Programmable	Hard wired	Easy							
		Digistat* Range							
	Wireless	Digistat* Range							

Wiring Information for Twinzone Control Systems with LWC3 Junction Boxes

LWC3 Junction Box

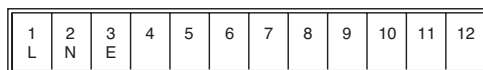

Pump

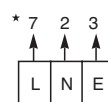

Boiler

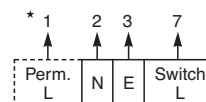

Room Thermostat

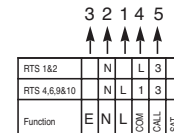

Cyl. Thermostat

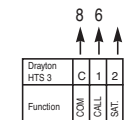

Programmer

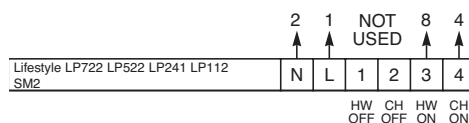

Mains Input - 230V a.c.

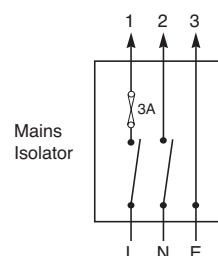

Motorised Valve

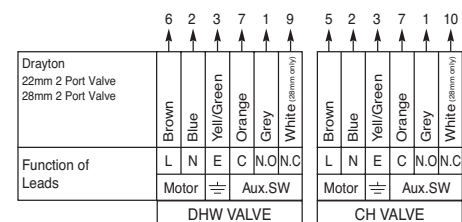

The white wire (28mm Valves) becomes live when the valve closes, it is not used and is wired to 'spare' terminals for safe isolation.

*Refer to Boiler Handbook for wiring details of Pump Overrun boilers. Use boiler manufacturers instructions.

Connections: The numbers printed at the tip of each arrow represent the Junction Box Terminals to which those leads or terminals should be connected.

Biflo Control System

FOR FULLY PUMPED SYSTEMS

OPERATION

In a fully pumped system the boiler provides a common supply of heated water which is fed to the motorised valve by the pump. The mid-position valve has three positions of operation, these depend on demand from the thermostats – see table below.

In 'mid-position' the valve directs the flow of heated water to both heating and hot water circuits.

Should either thermostat become satisfied, the valve will move leaving only the heating or the hot water port open. The boiler and pump will continue running whilst there is a demand from one or both thermostats. If both thermostats become satisfied the pump and boiler will switch off to save fuel.

Room Thermostat	Cylinder Thermostat	Valve Positions
Calling for heat	Calling for heat	Mid-position 'M'
Calling for heat	Satisfied	Heating only 'H'
Satisfied	Calling for heat	Hot water only 'W'

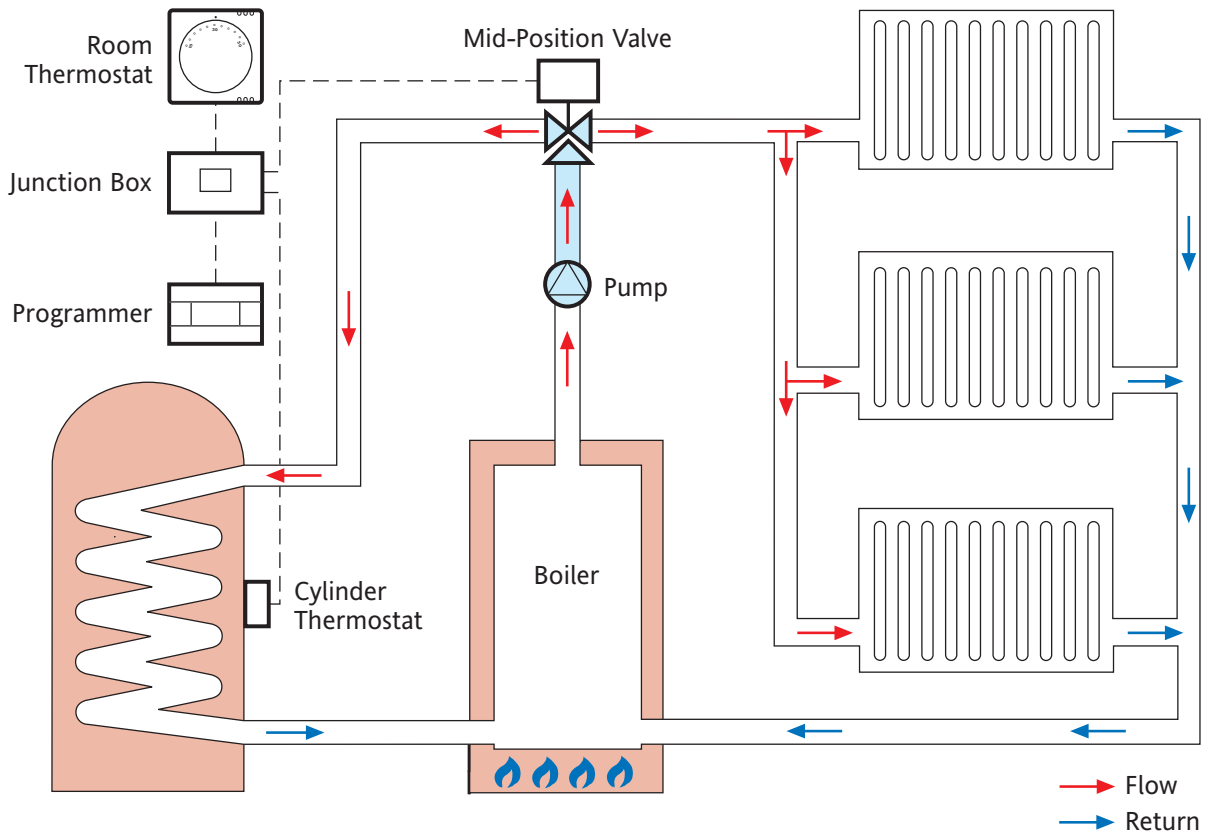

Biflo Valve Control Systems

WIRING DIAGRAMS FOR LWCI WIRING CENTRE

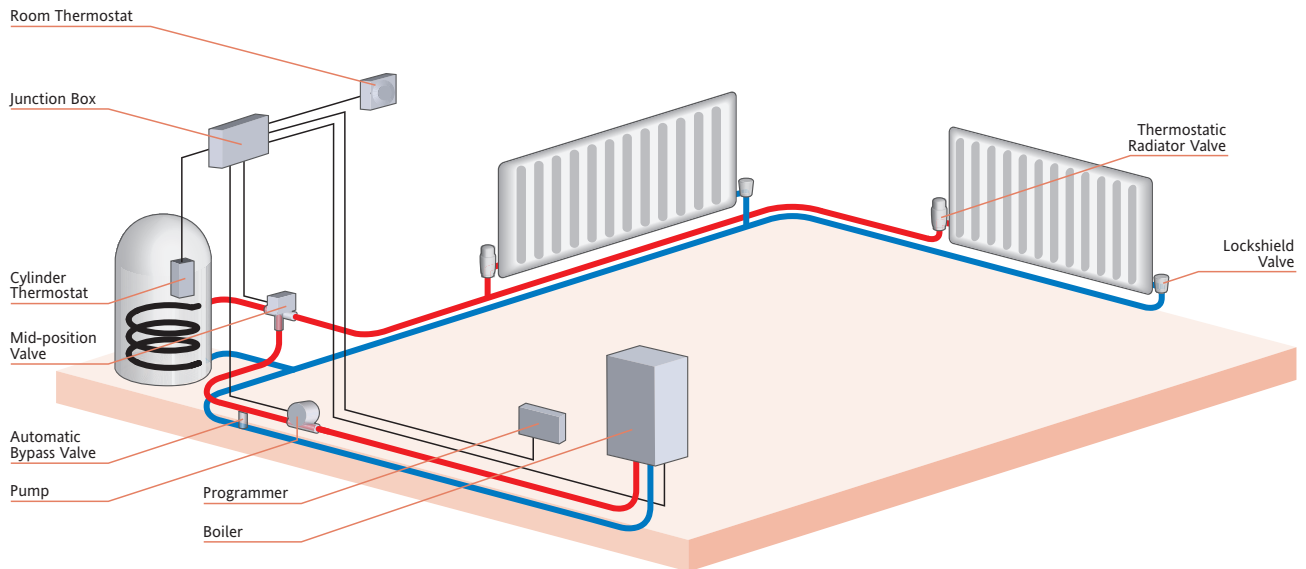

Room thermostat	Time Control	TRV	Wiring Centre	Cylinder Thermostat	Motorised Valve (x2)
Non-programmable Hard wired	RTS	Timer Electronic Lifestyle LP	RT212 LWCI	HTS3	22mm mid position
	Combi-Stat	Mechanical SMI	RT414 LWC3	Digistat+C RF	
	Digistat+	Programmer Electronic Lifestyle LP	TRV4		
	Wireless Digistat+RF	Mechanical SM2			
Programmable Hard wired	Easy				
	Digistat+ Range				
	Wireless Digistat+ Range				

Wiring Information for Biflo Control Panels with LWCI Wiring Centres

Wiring Centre - BASIC LINKS

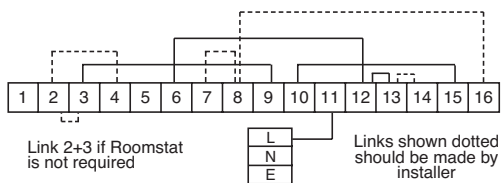

Pump

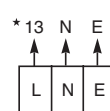

Boiler

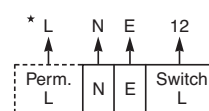

Room Thermostat

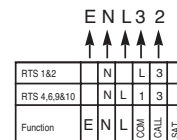

Cyl. Thermostat

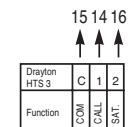

Programmer



Mains Input - 230V a.c.

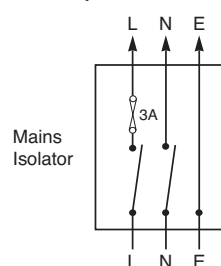

Motorised Valve

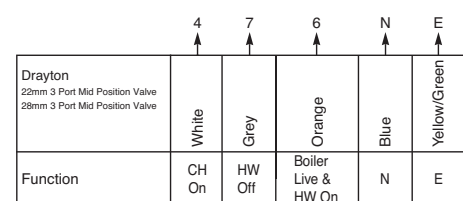

*Refer to Boiler Handbook for wiring details of Pump Overrun boilers. Use boiler manufacturers instructions.

Connections: The numbers printed at the tip of each arrow represent the Wiring Centre Terminals to which those leads or terminals should be connected.

Biflo Valve Control Systems

WIRING DIAGRAMS FOR LWC3 JUNCTION BOXES

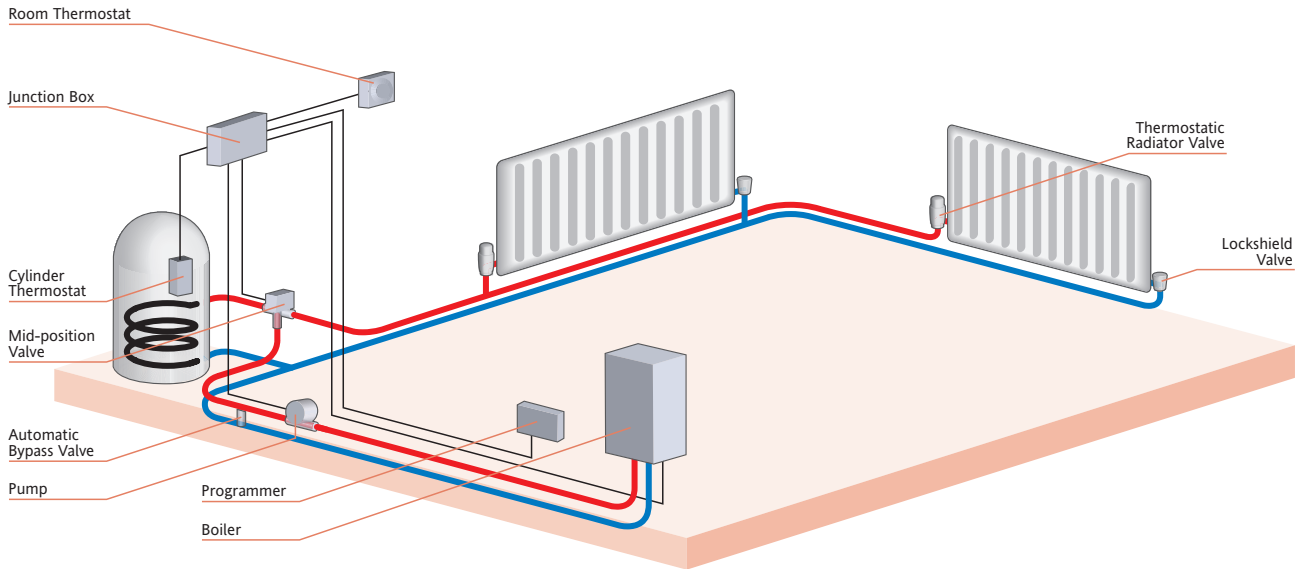

Room thermostat			Time Control			TRV	Wiring Centre	Cylinder Thermostat	Motorised Valve (x2)	
Non-programmable	Hard wired	RTS	Timer	Electronic	Lifestyle LP	RT2I2	LWC1	HTS3	22mm mid position	
		Combi-Stat			SM1	RT4I4	LWC3	Digistat+C RF		
		Digistat*			Programmer	Electronic	Lifestyle LP	TRV4		
Programmable	Hard wired	Easy	Programmer	Mechanical	SM2					
		Digistat+ RF								
		Digistat+ Range								
Wireless	Digistat+ Range									

Wiring Information for Biflo Control Panels with LWC3 Junction Boxes

LWC3 Junction Box

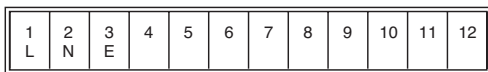

Pump

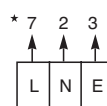

Boiler

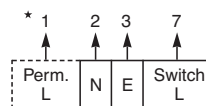

Room Thermostat

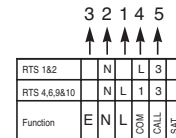

Cyl. Thermostat

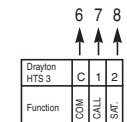

Programmer

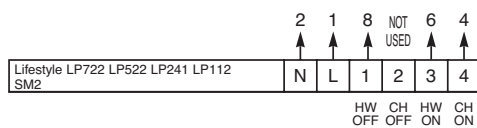

Mains Input - 230V a.c.

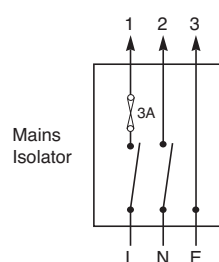

Motorised Valve

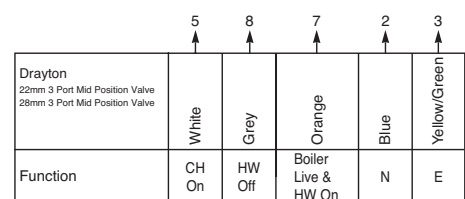

*Refer to Boiler Handbook for wiring details of Pump Overrun boilers. Use boiler manufacturers instructions.

Connections: The numbers printed at the tip of each arrow represent the Junction Box Terminals to which those leads or terminals should be connected.

Combi Boiler System

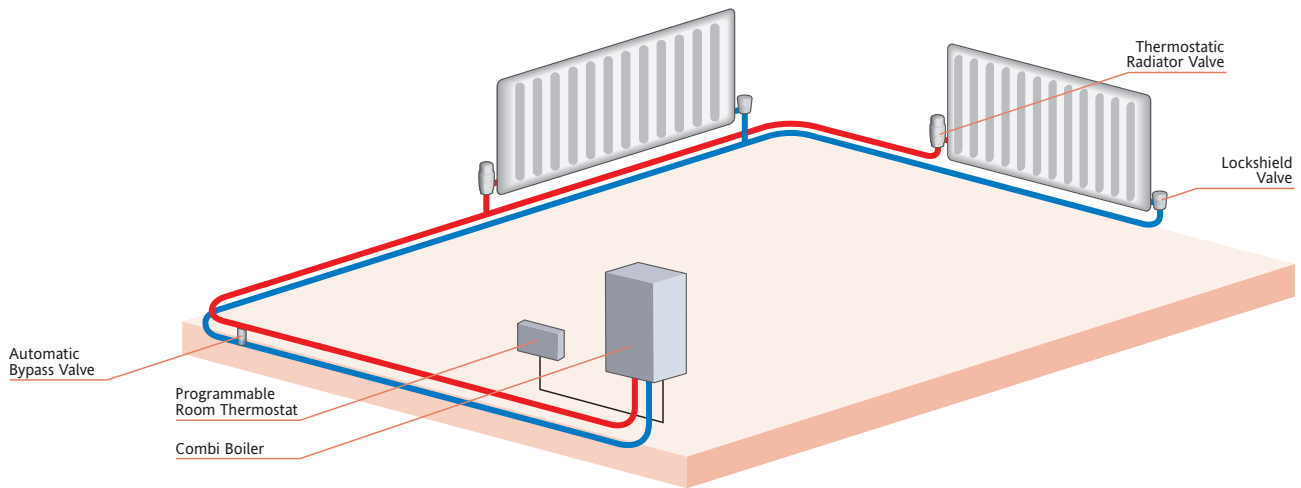

Room thermostat			Time Control			TRV
Programmable	Hard wired	Easy	Timer	Electronic	Lifestyle LP	RT2I2
		Digistat+ Range				RT4I4
Non-Programmable	Hard wired	Wireless	Programmer	Electronic	Lifestyle LP	TRV4
		RTS				
		Combi-Stat				
		Digistat+				
	Wireless	Digistat+RF				

Wiring Information for Combi Boiler Systems

Room Thermostat (applicable to Digistat+ Range)

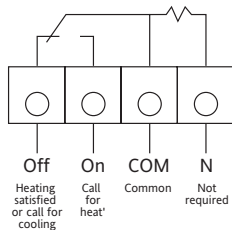

FOR FIXED WIRING ONLY

RTS1, RTS2, RTS3

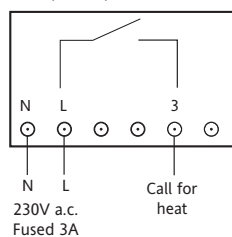

SCR Receiver (applicable to Digistat+ RF Range)

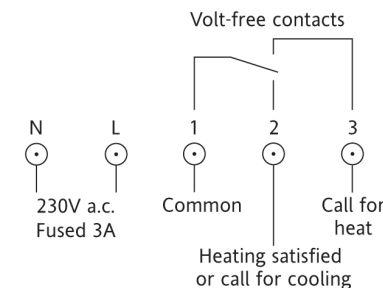

RTS4, RTS5, RTS9, RTS10

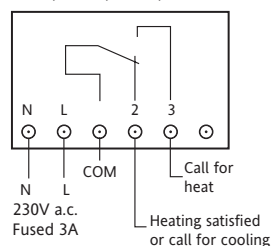

Combi-Stat

3 wire connection. **Max load = 2A.**
Suitable for most wet CH systems.

230V a.c.
Fused 3A

2 wire connection. No neutral. **Load = 0.1A to 0.6A.**
Suitable for most wet CH systems.

Note: Use this connection for gas CH systems, where there is no neutral wire, and follow set-up procedure. If current reading above 0.6 amps, wire as 2 wire connection opposite. 2 wire connection no Neutral.

24V-230V a.c./d.c.
Fused 3A

2 wire connection. No neutral. **Load = 0.6A to 6A.**
Typically for higher loads (i.e. electric heating)

24V-230V a.c./d.c.
suitably rated fuse

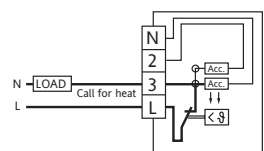
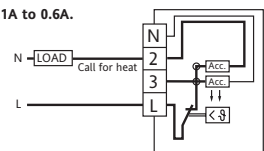
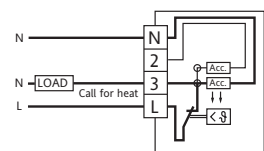

*Refer to Boiler Handbook for wiring details of Pump Overrun boilers. Use boiler manufacturers instructions.

Two Port Zone Valve System

WITH ADDITIONAL HEATING ZONE

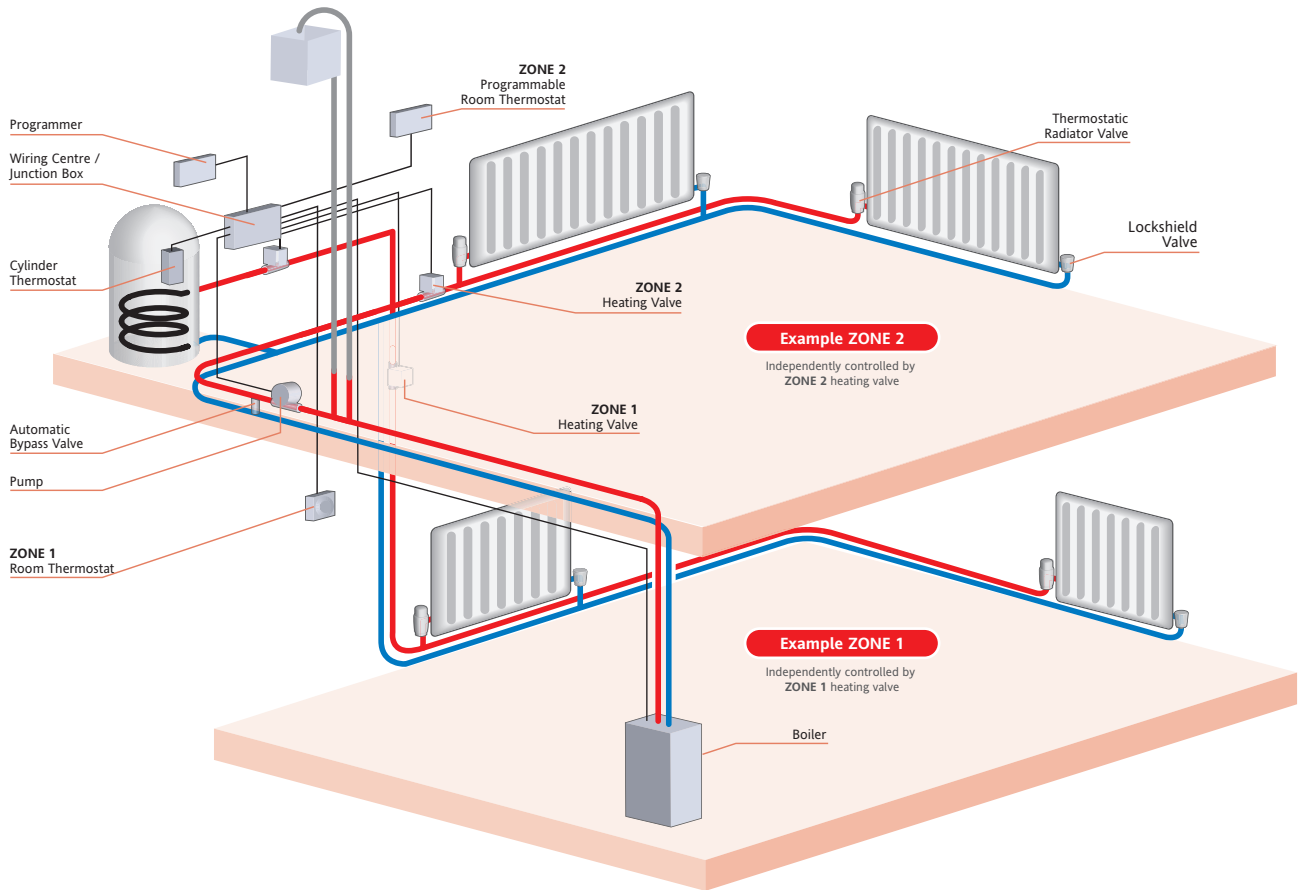

Wiring Information for Two Port Zone Valve Systems with LWCI Wiring Centre

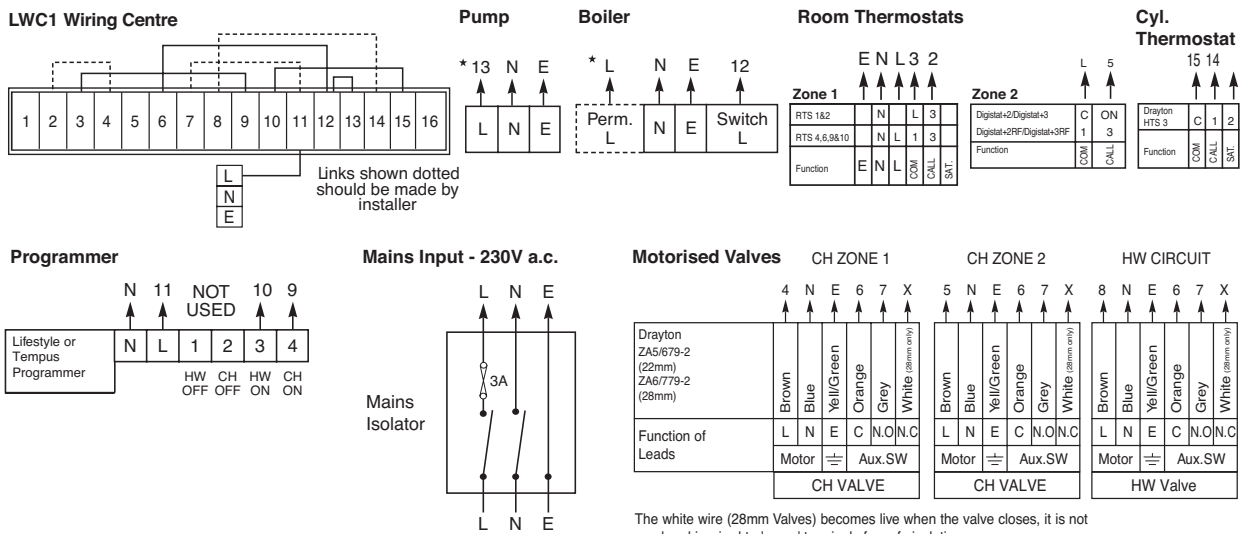

*Refer to Boiler Handbook for wiring details of Pump Overrun boilers. Use boiler manufacturers instructions.

Connections: The numbers printed at the tip of each arrow represent the Junction Box Terminals to which those leads or terminals should be connected.

THE GENUINE ARTICLE

• Airvents

• Quality surface finish

• Click-stop settings

• Drayton logo

• Non-stick internals
• Presetting
• Replaceable parts



The original and the best TRV4

- A-rated by TELL
- Keymark approved to EN215

 The NEW TRV4 White

Call: **+44 (0) 845 130 5522**

Technical Support: **0845 130 7722** | Customer Services: **0845 130 5522**
www.draytoncontrols.co.uk | customer.care@draytoncontrols.co.uk

Click here to
watch our TRV4
installation video



Commissioning Instructions

DOMESTIC HEATING SYSTEMS WITH TRVs

IMPORTANT: Read all instructions before commencing work. All work should be carried out by a competent person.

This commissioning procedure should be carried out on any wet central heating system fitted with thermostatic radiator valves (TRVs).

Failure to correctly balance a system can lead to complaints of inefficient operation and criticism of the operational abilities of thermostatic radiator valves, when in fact the valves are not the source of the problem. Common complaints raised by home owners include:

- Rooms are slow to reach temperature even though radiators are sized correctly
- Some rooms with correctly sized radiators never reach temperature during cold periods
- Room temperatures fluctuate particularly if the TRV is on a low setting

It must be remembered that no amount of commissioning and adjustment will compensate for a poorly designed or installed system.

There is no substitute for good design. Drayton thermostatic radiator valves are designed, tested and certified to meet with the stringent European standard EN215 and are manufactured in factories assessed and certified to the quality standard ISO9001

To commission your heating system you will need two contact thermometers and a presetting tool (07 35 162).

STEP 1 – SYSTEM CLEANSING

Before filling a heating system and switching it on, it is imperative that a thorough flushing procedure is carried out to BS7593. Residues frequently found in new heating systems include grit, metal chippings, unused flux, solder residues, hemp and mineral oil. In existing systems rust and magnetite can also be present.

Whilst BS7593 and CIBSE Code W refer to flushing as part of their codes on water treatment and commissioning, the most practical advice is to use a proprietary cleanser and follow the manufacturers' instructions. Ensure that TRV heads are either set to the maximum setting or removed altogether during flushing as full flow through the system is required.

STEP 2 – REFILLING

Having flushed the system thoroughly it is recommended that a proprietary inhibitor is added when the system is refilled. The inhibitor manufacturers' instructions should be adhered to.

STEP 3 – SYSTEM BALANCING

For a radiator to give the heat output it is capable of it must have water at the right temperature and flow rate. The flow temperature is obviously determined by the boiler thermostat but the flow

rate is determined by a combination of the pump size/setting and the resistance through each and every loop of the heating circuit (ie. each and every radiator). In order to get equal flow rates through each radiator the system must be correctly balanced. This is usually achieved through adjustment of the lockshield valves on each radiator to achieve optimum flow. However it is recommended to balance the system using the TRV valve body and the presetting tool. This has the advantage that, once balanced, the system cannot be altered without the use of the presetting tool, even if radiators are removed. The lockshield valve then remains fully open and can be shut to isolate the radiator without interfering with the balancing in the TRV valve.

Standards and codes covering balancing do exist but these generally call for sophisticated temperature measuring equipment and the provision of pressure tapplings throughout the heating system. This is obviously not practical in the normal domestic installation so it is recommended you use the two contact thermometers for measuring pipe temperatures and take the following steps:

1. The boiler should be commissioned in accordance with the appliance manufacturer's instructions. Then the whole system should be brought up to design flow temperature with the pump running, all TRVs, lockshield valves and manual wheelhead valves should be fully open and the primary to the hot water cylinder closed.

2. Open and adjust the bypass, if fitted, in accordance with the boiler manufacturer's instructions. This normally involves closing all radiator valves and, with the boiler and pump running, adjusting the bypass to ensure minimum system noise at all flow temperatures, until the boiler thermostat switches off. The bypass should NEVER be left fully closed.

If more than 50% of the radiators have TRVs fitted, we recommend using an auto by-pass valve (such as the Drayton DTB) and following instructions supplied.

Before balancing the radiators check that water is not pumping over from, nor air being drawn into the open vent with the system in this condition.

3. Switch off the boiler and pump. Check all lockshield valves are fully open. Put the contact thermometers to the flow and return pipes adjacent to the valves, switch on the boiler and pump, then wait for the temperature readings to stabilise. The TRV valve needs adjusting to achieve the design temperature drop between flow and return (usually IIC). To increase the temperature drop the flow rate should be reduced by using the presetting tool on the TRV valve.

4. i. Remove the thermostatic or wheelhead and loosen the locking ring.



WARNING: DO NOT LOOSEN MORE THAN A QUARTER TURN (90°), using the end of the adjusting key with the four equal width pegs.

ii. The valve insert can now be rotated using the end of the adjusting key with the two unequal width pegs.

IMPORTANT: Adjust in a clockwise direction only.

Note: The numbers on the key correspond with the numbers on the top rim of the valve insert.

iii. Line up required setting number with the semi-circular notch on the top of the valve body and then re-tighten the locking ring. DO NOT OVER TIGHTEN. Never set at in-between or half numbers.

Pre-setting keys are available in packs of two, part number 07 35 162 from all leading plumbing merchants.

5. Repeat this procedure for all radiators working away from the pump.

6. Gradually open the primary flow to the hot water cylinder again using the contact thermometers to obtain 11°C drop between flow and return.

7. Fit the thermostatic heads to the radiator valves and set them to the desired temperature. Allow two hours for the room temperatures to stabilise

NOTES

1. If excessive noise is heard at any time during the system balancing routine this may indicate the pump 'head' is set too high or the pipework has been incorrectly sized causing the water to flow at an excessively high speed. It is strongly recommended that the differential pressure across the thermostatic valves should not exceed 0.2 bar to avoid flow related noise. A differential pressure regulating device, e.g. the Drayton DTB Automatic by-pass valve should be used.

2. If a separate bypass has not been fitted, we would recommend a final check after the system has been balanced. Set all the TRVs to frost or off, with only the heating circuit "On" the open vent should be checked for pumping over or ingress of air.

3. B.S. 5449 states that TRVs should not be the sole means of controlling a heating circuit. They must be used in conjunction with other controls, such as a room thermostat which will switch off the boiler when there is no demand for heating. TRVs must not be fitted in the same room or area as the room thermostat.

REPLACEMENT OF GLAND SEAL

1. Gland seal can be replaced without draining the system. However there may be a slight seepage of water when the old seal is removed. It is recommended that dust sheets/small bowl is used to catch any drips.

2. Use the presetting key to remove the old gland seal.

3. Fit new Gland Seal and Re-tighten until the top of the Gland Seal is level with the top lip of the valve insert. DO NOT OVER TIGHTEN

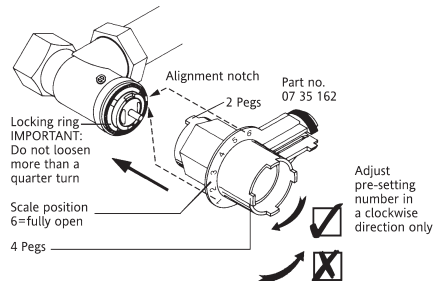

i. Remove the thermostatic or wheelhead and loosen the locking ring.

WARNING: DO NOT LOOSEN MORE THAN A QUARTER TURN (90°), using the end of the adjusting key with the four equal width pegs.

ii. The valve insert can now be rotated using the end of the adjusting key with the two unequal width pegs.

IMPORTANT: Adjust in a clockwise direction only.

Note: The numbers on the key correspond with the numbers on the top rim of the valve insert.

iii. Line up required setting number with the semi-circular notch on the top of the valve body and then re-tighten the locking ring.

DO NOT OVER TIGHTEN.

Never set at in-between or half numbers.

Presetting keys are available in packs of two, part number 07 35 162.

Kv values $Kv = \sqrt{\frac{Q}{\Delta p}}$ $Q = M^3/h$ $\Delta p = \text{Differential pressure bar}$

	Pre-setting Nr.	Kv (IK)	Kv (2K)	Kvs (max)	Max. Δp against which valve will shut	(2K)
EB 3/8	1	0.10	0.10	0.10	1 bar	-
	2	0.14	0.14	0.14	1 bar	-
	3	0.19	0.22	0.22	1 bar	-
	4	0.25	0.35	0.38	1 bar	0.16
	5	0.28	0.47	0.66	1 bar	0.48
	6	0.28	0.47	0.79	1 bar	0.64
EB 1/2 & 1/2	1	0.10	0.10	0.10	1 bar	-
	2	0.14	0.14	0.14	1 bar	-
	3	0.19	0.22	0.22	1 bar	-
	4	0.25	0.35	0.38	1 bar	0.16
	5	0.28	0.47	0.66	1 bar	0.48
	6	0.32	0.57	1.01	1 bar	0.68
EB 3/4	1	0.10	0.10	0.10	1 bar	-
	2	0.14	0.14	0.14	1 bar	-
	3	0.19	0.22	0.22	1 bar	-
	4	0.25	0.35	0.38	1 bar	0.16
	5	0.28	0.47	0.66	1 bar	0.48
	6	0.35	0.66	1.50	1 bar	0.80
EB 1	-	-	1.40	5.00	0.5	0.92

Drayton

by Schneider Electric



Technical Support: **0845 130 7722**

www.draytoncontrols.co.uk | customer.care@draytoncontrols.co.uk



Customer Services: **0845 130 5522**

D73-15

In accordance with our continuous improvement procedures, we reserve the right to change design features and specifications without prior notification. The Data contained in this document is for guidance only. Drayton accepts no liability for any consequential losses, injury or damage resulting from the use of this document or the information contained within.



FM 00607