

# Grant **Product Guide**

A complete guide to Grant high efficiency technologies



1st March 2017

This supersedes all previous issues



# Contents

---

<b>Oil Fired Boilers &amp; Flues</b>	<b>4-13</b>
Vortex Eco Range - utility & external (outdoor modules)	4
Vortex Pro Range - utility & external (outdoor modules)	5
Vortex Pro Range - combi & boiler house models	6
VortexBlue Range - utility, external & combi models	7
EZ-Fit Flue systems	8-13
<b>Air Source Heat Pumps</b>	<b>14-15</b>
Aerona <sup>3</sup> air to water heat pumps	14-15
<b>Oil boiler/Heat Pump Hybrid</b>	<b>16-17</b>
Grant VortexAir Hybrid	16-17
<b>Cylinders &amp; Thermal Stores</b>	<b>18-25</b>
MonoWave heat pump cylinders	18-19
DuoWave heat pump cylinders	18-19
DuoWave solar cylinders	20-21
DuoWave Plus cylinders	22
ThermaWave thermal stores	23-25
<b>Solar Thermal Systems</b>	<b>26-31</b>
On roof kits	28
In roof kits	29-30
Flat roof kits	30
Accessories	31
<b>Biomass Boilers &amp; Accessories</b>	<b>32-42</b>
Vecta wood pellet boiler range - internal models	32-33
Vecta wood pellet boiler range - external models	34-35
Vecta wood pellet boiler range - internal side pellet stores	36
Vecta wood pellet boiler range - external side pellet stores	37
Spira wood pellet boiler range - internal models	38-41
Biomass flues	42-43
SpiraPod Range	44
SpiraVac vacuum systems	45
Wood pellet stores	46

---

**Magnetic Central Heating Filter** 47

MagOne filter 47

**Energy Management Controls** 48-51

Controllers 48

Low loss headers 49-50

Zone pump kits 51

# Grant Vortex **Eco** Range



- Stainless steel heat exchanger
- SAP 2009 seasonal efficiencies of 90.3% - 91.6%
- Exceptionally quiet operation
- Multidirectional flue options
- Simplified casing, control panel and pipework arrangement



Product Code	Output		Dimensions			Weight (KG)	Burner
	Btu/h	KW	H	W	D		
<b>Internal standard models - white cased</b>							
VTXECO15/21	50-70	15-21	860	430	605	97	RDB2.2
VTXECO21/26	70-90	21-26	860	430	605	97	RDB2.2
VTXECO26/35	90-120	26-35	900	470	603	127	RDB2.2
<b>Internal sealed system models - white cased</b>							
VTXSECO15/21	50-70	15-21	860	430	605	136	RDB2.2
VTXSECO21/26	70-90	21-26	860	430	605	136	RDB2.2
VTXSECO26/35	90-120	26-35	900	470	603	152	RDB2.2
<b>External standard modules (inc flue) - powder coated case</b>							
VTXOMECO15/21	50-70	15-21	908	505	800	113	RDB2.2
VTXOMECO21/26	70-90	21-26	908	505	800	113	RDB2.2
VTXOMECO26/35	90-120	26-35	908	505	800	142	RDB2.2
<b>External sealed system models (inc flue) - powder coated cased</b>							
VTXSOMECO15/21	50-70	15-21	908	505	800	136	RDB2.2
VTXSOMECO21/26	70-90	21-26	908	505	800	136	RDB2.2
VTXSOMECO26/35	90-120	26-35	908	505	800	152	RDB2.2
<b>Wall hung internal standard models - white cased</b>							
VTXWH12/16	40-55	12-16	850	580	322	86	MAX1
VTXWH16/21	55-70	16-21	850	580	322	86	MAX1
<b>Wall hung internal sealed system models - white cased</b>							
VTXSWH12/16	40-55	12-16	850	580	322	98	MAX1
VTXSWH16/21	55-70	16-21	850	580	322	98	MAX1
<b>Wall hung external standard models (inc flue) - powder coated cased</b>							
VTXOMWH12/16	40-55	12-16	837	635	366	93	MAX1
VTXOMWH16/21	55-70	16-21	837	635	366	93	MAX1
<b>Wall hung external sealed system models (inc flue) - powder coated cased</b>							
VTXSOMWH12/16	40-55	12-16	837	635	366	97	MAX1
VTXSOMWH16/21	55-70	16-21	837	635	366	97	MAX1

# Grant Vortex **Pro** Range



- Award winning range
- Stainless steel heat exchanger
- SAP 2009 seasonal efficiencies of 90.7% - 93.3%
- Exceptionally quiet operation
- Multidirectional flue options
- Riello burner technology



Product Code	Output		Dimensions			Weight (KG)	Burner
	Btu/h	KW	H	W	D		
<b>Internal standard models - white cased</b>							
VTX15/21	50-70	15-21	855	348	566	97	RDB2.2
VTX15/26	50-90	15-26	860	470	603	130	RDB1
VTX26/36	90-123	26-36	900	470	603	144	RDB2
VTX36/46	123-157	36-46	900	470	603	144	RDB2.2
VTX46/58	157-200	46-58	1234	563	786	268	RDB3.2
VTX58/70	200-240	58-70	1234	563	786	282	RDB3.2
<b>Internal sealed system models - white cased</b>							
VTXS15/26	50-90	15-26	860	470	603	138	RDB1
VTXS26/36	90-123	26-36	900	470	603	167	RDB2
VTXS36/46	123-157	36-46	900	470	603	164	RDB2.2
<b>External standard modules (inc flue) - powder coated case</b>							
VTXOM15/21	50-70	15-21	879	385	734	109	RDB2.2
VTXOM15/26	50-90	15-26	908	505	800	143	RDB1
VTXOM26/36	90-123	26-36	908	505	800	162	RDB2
VTXOM36/46	123-157	36-46	908	505	800	162	RDB2.2
VTXOM46/58	157-200	46-58	1240	587	945	274	RDB3.2
VTXOM58/70	200-240	58-70	1240	587	945	288	RDB3.2

<b>Accessories &amp; Control Options</b>	
Product Code	Description
VTXOMSSKIT21	10 Litre Sealed System Kit for VTXOM1521
VTXOMSSKIT26	12 Litre Sealed System Kit for VTXOM1526
VTXOMSSKIT46	16 Litre Sealed System Kit for VTXOM2636/ VTXOM3646
EPKIT	7 Day, Twin Channel Plug-In Programmer (for internal models)

# Grant Vortex **Pro** Range



- Award winning range
- Stainless steel heat exchanger
- SAP 2009 seasonal efficiencies of 90.7% - 93.3%
- Exceptionally quiet operation
- Multidirectional flue options
- Riello burner technology



Product Code	Output		Dimensions			Weight (KG)	Burner
	Btu/h	KW	H	W	D		
<b>Internal boiler house models - blue cased</b>							
VTXBH26/36	90-123	26-36	705	460	600	121	RDB2
VTXBH36/46	123-157	36-46	705	460	600	121	RDB2.2
VTXBH46/58	157-200	46-58	1022	540	868	222	RDB3.2
VTXBH58/70	200-240	58-70	1022	540	868	236	RDB3.2
<b>Internal Combi models - white cased</b>							
VTXCOMBI21	70	21	860	614	609	160	RDB2.2
VTXCOMBI26	90	26	860	614	609	177	RDB1
VTXCOMBI36	123	36	900	615	609	200	RDB2.2
<b>Internal Combi XS models - white cased</b>							
VTXSCOMBI26	90	26	857	515	613	165	RDB2.2
<b>External Combi modules (incl flue) - powder coated cased</b>							
VTXOMCOMBI21	70	21	945	658	754	181	RDB2.2
VTXOMCOMBI26	90	26	945	658	754	206	RDB1
VTXOMCOMBI36	123	36	945	658	754	225	RDB2.2

<b>Combi Models Control Options</b>	
Product Code	Description
MTKIT	Internal 24hr Single Channel Mechanical Timer Kit
EPKIT	7 Day, Twin Channel Plug-In Programmer (for internal models)

# Grant **VortexBlue** Range



- Market leading Riello Blue Flame burner
- Gross SAP 2009 seasonal efficiencies of 89.5% - 93.3%
- Burner NOx emissions below 2018 European limit of 120mg/kWh
- Neon diagnostic indicators
- Multidirectional flue options



Product Code	Output		Dimensions			Weight (KG)	Burner
	Btu/h	KW	H	W	D		
<b>Internal standard models - white cased</b>							
VTXBF21	50-70	15-21	860	470	603	130	Riello RDB BLU
VTXBF26	70-90	21-26	860	470	603	130	Riello RDB BLU
VTXBF36	90-123	26-36	900	470	603	144	Riello RDB BLU
<b>Internal sealed system models - white cased</b>							
VTXSBF21	50-70	15-21	860	470	603	130	Riello RDB BLU
VTXSBF26	70-90	21-26	860	470	603	130	Riello RDB BLU
VTXSBF36	90-123	26-36	900	470	603	144	Riello RDB BLU
<b>Internal combi modules - white cased</b>							
VTXBFCOM21	70	21	860	614	609	160	Riello RDB BLU
VTXBFCOM26	90	26	860	614	609	177	Riello RDB BLU
VTXBFCOM36	123	36	900	614	609	200	Riello RDB BLU
<b>External modules (incl flue) - powder coated case</b>							
VTXBFOM21	50-70	15-21	908	505	1005	143	Riello RDB BLU
VTXBFOM26	70-90	21-26	908	505	1005	143	Riello RDB BLU
VTXBFOM36	90-123	26-36	908	505	1005	162	Riello RDB BLU
<b>External combi modules (incl flue) - powder coated cased</b>							
VTXBFOMCOM21	70	21	945	658	966	181	Riello RDB BLU
VTXBFOMCOM26	90	26	945	658	966	206	Riello RDB BLU
VTXBFOMCOM36	123	36	945	658	966	225	Riello RDB BLU

## Low level balanced flue kits

- Low level
- Stainless steel
- Balanced
- Suitable for all internal Vortex models
- Terminal section and guard are black painted
- Plume diverter kits available

Product Code	Output (kW)	Description
EZ90B	12-26	Standard flue kit – Walls up to 450mm Includes s/s terminal guard (Black painted finish)
EZ90SB	12-26	Short flue kit – Single skin walls up to 230mm Includes s/s terminal guard (Black painted finish)
X90S	12-26	Extension 225mm
X90M	12-26	Extension 450mm
X90L	12-26	Extension 675mm
EZELB90	12-26	90° Elbow Kit (Includes 90° elbow and 225mm Extension)
EZ45/90	12-26	45° Elbow Kit (Includes 45° elbow and 225mm Extension)
EZ45/90S	12-26	Short elbow only up to 26kW
GPDA90B	12-26	Adjustable plume diverter kit 80mm x 2 metres (Black painted finish)
GPD250EXT/90B	12-26	Extension 250mm (Black painted finish)
GPD500EXT/90B	12-26	Extension 500mm (Black painted finish)
GPD1000EXT/90B	12-26	Extension 1000mm (Black painted finish)
GPDA45/90B	12-26	45° elbow (Black painted finish)
GPDBRKT90B	12-26	Wall bracket (Black painted finish)
EZ200B	26-70	Standard flue kit – Walls up to 450mm Includes s/s terminal guard (Black painted finish)
EZ200SB	26-70	Short flue kit – Single skin walls up to 230mm Includes s/s terminal guard (Black painted finish)
X200S	26-70	Extension 225mm
X200M	26-70	Extension 450mm
X200L	26-70	Extension 675mm
EZELB200	26-70	90° Elbow Kit (Includes 90° elbow and 225mm Extension)
EZ45/200	26-70	45° Elbow Kit (Includes 45° elbow and 225mm Extension)
EZ45/200S	26-70	Short elbow only above 26kW
GPDA200B	26-70	Adjustable plume diverter kit 100mm x 2 metres (Black painted finish)
GPD250EXT/200B	26-70	Extension 250mm (Black painted finish)
GPD500EXT/200B	26-70	Extension 500mm (Black painted finish)
GPD1000EXT/200B	26-70	Extension 1000mm (Black painted finish)
GPDA45/200B	26-70	45° elbow (Black painted finish)
GPDBRKT200B	26-70	Wall bracket (Black painted finish)



## High level/ vertical balanced flue kits

- High level/ Vertical
- Stainless steel white powder coated
- Balanced
- Suitable for all internal Vortex models
- Easy to install

Product Code	Output (kW)	Description
HLK015090	12-26	1.2 metre High level adjustable flue kit c/w 90° elbow and terminal
VTK055090	12-26	Adjustable Vertical 3 metre flue kit c/w terminal and storm collar
EXTK31225/90	12-26	Extension 225mm (9")
EXTK09450/90	12-26	Extension 450mm (18")
EXTK11950/90	12-26	Extension 950mm (38")
EXTK13ADJ/90	12-26	Adjustable extension 275 - 450mm (10 to 18")
ELBK2145/90	12-26	45° elbow
VTMF90/200	12-70	Pitched master flashing [aluminium]
VTK25P90	12-26	Pitched flashing [lead]
VTK27F90	12-26	Flat flashing
BRK2990	12-26	Wall bracket [galvanised]
VTTEXT90	12-26	Black extension for vertical terminal 80mm x 1mtr
HLK0290200	26-70	1.2 metre High level adjustable flue kit c/w 90° elbow and terminal
VTK0690200	26-70	Adjustable Vertical 3 metre flue kit c/w terminal and storm collar
EXTK32225/200	26-70	Extension 225mm (9")
EXTK10450/200	26-70	Extension 450mm (18")
EXTK12950/200	26-70	Extension 950mm (38")
EXTK14ADJ/200	26-70	Adjustable extension 275 - 450mm (10 to 18")
ELBK2245/200	26-70	45° elbow
VTMF90/200	12-70	Pitched master flashing [aluminium]
VTK26P240	26-70	Pitched flashing [lead]
VTK26P200X	26-70	Pitched flashing [lead replacement, incl collar]
VTK 28F200	26-70	Flat flashing
BRK30200	26-70	Wall bracket [galvanised]
VTTEXT200	26-70	Black extension for vertical terminal 100mm x 1mtr

**NOTE:**

High level/vertical flues, extensions and accessories can be used with all internal boilers.

Vertical flue kits can be extended to a maximum straight length of 12 metres. Deduct 1 metre for each 45° elbow (max 6 elbows).

High level flue kits can be extended to a maximum length of 10 metres. Deduct 1 metre for each 45° elbow (max 6 elbows).

For information on Plume Diverter Kits for high level flues, please contact our Technical Department

## External High Level/ Vertical balanced flue kits

- High level/ Vertical
- Stainless steel
- Balanced
- Twin wall insulated vertical extensions
- Suitable for all internal and external Vortex models
- Black painted

Product Code	Output (kW)	Description
GK90	12-26	Standard Starter Kit (Stainless Steel)
GK90S	12-26	Short Starter Kit (Stainless Steel)
GKM90	12-26	Outdoor Module Starter (Elbow) + Test point
GKM90C	12-26	Outdoor Module Starter (Straight) + Test point
GX150/90	12-26	Extension 150mm
GX250/90	12-26	Extension 250mm
GX450/90	12-26	Extension 450mm
GX950/90	12-26	Extension 950mm
GXA250/90	12-26	Adjustable Extension 195 - 270mm
GE45/90	12-26	45° Elbow
GTL90	12-26	Straight Terminal Only
GTH90	12-26	High level 90° Terminal
GTV90	12-26	Vertical Terminal
GWB90	12-26	Wall Bracket
GEB90	12-26	Extended Wall Bracket
GK200	26-70*	Standard Starter Kit (Stainless Steel)
GK200S	26-70*	Short Starter Kit (Stainless Steel)
GKM200	26-46*	Outdoor Module Starter (Elbow) + Test point
GKM200C	26-46*	Outdoor Module Starter (Straight) + Test point
GX150/200	26-70*	Extension 150mm
GX250/200	26-70*	Extension 250mm
GX450/200	26-70*	Extension 450mm
GX950/200	26-70*	Extension 950mm
GXA250/200	26-70*	Adjustable Extension 195 - 270mm
GE45/200	26-70*	45° Elbow
GTL200	26-70*	Straight Terminal Only
GTH200	26-70*	High level 90° Terminal
GTV200	26-70*	Vertical Terminal
GWB200	26-70*	Wall Bracket
GEB200	26-70*	Extended Wall Bracket
CFA15/70	12-70	CF Adaptor/Connector from Orange to Green System

**NOTE:**

\*The Grant Eco Outdoor Modules VTXOMEKO2635 and VTXSOMEKO26/35 use the smaller 12-26 flue pipe.

Please use extensions from the Yellow System to extend starter kits horizontally.

The CFA15/70 is to only be used with the Grant Green and Orange Flue System. Fitting with any other flue system could invalidate the warranty of the boiler. If the CFA15/70 is not sent with components of the Green or Orange Systems, then full installation details will be required prior to despatch.

# Orange System

## Conventional flue kits

- Conventional flexi kits
- Smooth bore stainless steel liner
- White powder coated extensions
- Suitable for all internal Vortex models
- Available as complete kits

Product Code	Output (kW)	Description
GFKIT6/100	12-46	Flexi Kit 100mm dia x 6m
GFKIT8/100	12-46	Flexi Kit 100mm dia x 8m
GFKIT10/100	12-46	Flexi Kit 100mm dia x 10m
GFKIT11/100	12-46	Flexi Kit 100mm dia x 11m
GFKIT12/100	12-46	Flexi Kit 100mm dia x 12m
GFKIT14/100	12-46	Flexi Kit 100mm dia x 14m
GFKIT16/100	12-46	Flexi Kit 100mm dia x 16m
WX150/100	12-46	White Extension 150mm x 100mm dia
WX250/100	12-46	White Extension 250mm x 100mm dia
WX450/100	12-46	White Extension 450mm x 100mm dia
WX950/100	12-46	White Extension 950mm x 100mm dia
WXA250/100	12-46	235mm x 300mm x ø100mm White Adjustable Extension
WE45/100	12-46	White 45° Elbow x 100mm dia
GFKIT6/125	46-70	Flexi Kit 125mm dia x 6m
GFKIT8/125	46-70	Flexi Kit 125mm dia x 8m
GFKIT10/125	46-70	Flexi Kit 125mm dia x 10m
GFKIT11/125	46-70	Flexi Kit 125mm dia x 11m
GFKIT12/125	46-70	Flexi Kit 125mm dia x 12m
GFKIT14/125	46-70	Flexi Kit 125mm dia x 14m
GFKIT16/125	46-70	Flexi Kit 125mm dia x 16m
WX150/125	46-70	White Extension 150mm x 125mm dia
WX250/125	46-70	White Extension 250mm x 125mm dia
WX450/125	46-70	White Extension 450mm x 125mm dia
WX950/125	46-70	White Extension 950mm x 125mm dia
WXA250/125	46-70	235mm x 300mm x ø125mm White Adjustable Extension
WE45/125	46-70	White 45° Elbow x 125mm dia

Flexi Kit includes: Terminal/top plate/flexi-flue adaptor assembly, adaptor to flexi, boiler flue connector, locking band and fixing screws, plus tube of silicon and length of smooth bore insulated flexible flue liner.  
**NOTE:** Maximum vertical height from top of the boiler to the terminal is 19 metres. Maximum of 2 x 45° elbows can be used.

## Flexi Vertical balanced flue kits

- Balanced flexi kits
- Smooth bore stainless steel inner liner
- Stainless Steel outer liner
- Suitable for all internal Vortex models up to 26kW
- Available as complete kits

Product Code	Output (kW)	Description
GFX BF6/26COMR	12-26	6m Balanced Flexi Liner Kit
GFXBF8/26COMR	12-26	8m Balanced Flexi Liner Kit
GFXBF10/26COMR	12-26	10m Balanced Flexi Liner Kit
GFXBF12/26COMR	12-26	12m Balanced Flexi Liner Kit
EXTK31225/90	12-26	Extension 225mm (9")
EXTK09450/90	12-26	Extension 450mm (18")
EXTK11950/90	12-26	Extension 950mm (38")
EXTK13ADJ/90	12-26	Adjustable extension 275 - 450mm (10 to 18")
ELBK2145/90	12-26	45° elbow

Liner Kit includes: 125mm flexi liner, 80mm 316 stainless steel smooth bore flexi liner, Boiler Connector, Telescopic Extension, Rigid to Flexi Adaptor and Terminal Assembly (approximate height above boiler case 820 - 1220mm)

**NOTE:** Maximum vertical height from top of the boiler to the terminal is 20mtrs. Deduct 1mtr for each 45° elbow (max 4 elbows).

Ref	Location of outlet (see diagram opposite)	Pressure Jet (mm)	Condensing (mm)
A	Directly below an opening, air brick opening, opening window, etc.	600	1000**
B	Horizontally to an opening, air brick opening, opening window, etc.	600	1000**
C	Below a gutter, eaves or balcony with protection	75*	1000**
D	Below a gutter, eaves or balcony without protection	600	1000**
E	From vertical sanitary pipe work	300	
F	From an internal or external corner	300	
G	Above ground or balcony level	300	
H	From a surface or boundary facing the terminal	600	2500**
J	From a terminal facing the terminal	1200	
K	Vertically from a terminal on the same wall	1500	
L	Horizontally from a terminal on the same wall	750	
M	Above the highest point of an intersection with the roof	600	
N	From a vertical structure to the side of the terminal	750	
O	Above a vertical structure less than 750 mm from the side of the terminal	600	
P	From a ridge terminal to a vertical structure on the roof	1500	
Q	Above or to the side of any opening on a flat or sloping roof	300	
R	Below any opening on a sloping roof	1000	
S	From oil storage tank (Class 1)	1800***	

**Note:**

\* A heat shield at least 750mm wide must be fitted to provide protection of combustible material

\*\* Clearances required by BS 5410-1:2014 to alleviate the effect of plume nuisance. If a risk assessment shows that there will be no impact from plumbing, then the 'pressure jet' figure could apply - seek confirmation from Local Authority Building Control.

\*\*\* Seek guidance from OFTEC Book 3 (Oil Storage and Supply).

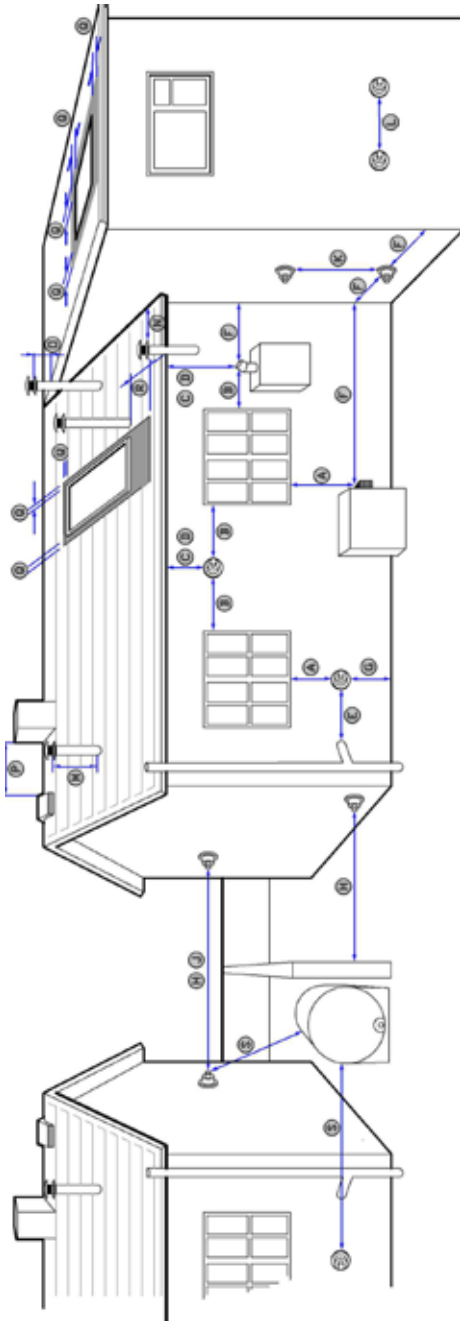

1. Appliances burning class D fuel have additional restrictions. Refer to BS 5410-1:2014.
2. Vertical structure in N, O and P includes tank or lift rooms, parapets, dormers, etc.
3. Terminating positions A to L are only permitted for appliances that have been approved for low level flue discharge when tested in accordance with BS EN 303-1, OFS A100 or OFS A101.
4. Terminating positions should be at least 1.8 metres from an oil storage tank (Class 1) unless a wall with at least 30 minutes fire resistance and extending 300 mm higher and wider than the tank is provided between the tank and the terminating position.
5. Where a flue is terminated less than 600 mm away from a projection above it and the projection consists of plastics or has a combustible or painted surface, then a heat shield of at least 750 mm wide should be fitted to protect these surfaces.
6. If the lowest part of the terminal is less than 2 metres above the ground, balcony, flat roof or other place to which any person has access, the terminal should be protected by a guard.
7. Notwithstanding the dimensions given above, a terminal should not be sited closer than 300 mm to combustible material. In the case of a thatched roof, double this separation distance should be provided. It is also advisable to treat the thatch with a fire retardant material and close wire in the immediate vicinity of the flue.
8. A flue or chimney should not pass through the roof within the shaded area delineated by dimensions Q and R.
9. Where protection is provided for plastics components, such as guttering, this should be to the standard specified by the manufacturer of the plastics components.
10. Terminals must not be sited under car ports.
11. Terminals at low levels (terminals under 2.1 metres) have more restrictive recommendations and should not be positioned near public footways, frequently used access routes, car parking spaces less than 2.5 metres from the terminal or patio's (hard surface area). Further guidance can be obtained from BS 5410-1:2014, OFTEC Book 4 (Installation) and Approved Document J. Grant UK flue products are fully compliant with the CE (Communauté Européenne/European Community) standards having undergone rigorous product testing.

# Grant Aeron<sup>3</sup> ASHP range



- Air to water
- Inverter driven
- MCS approved
- Single phase
- Compact size
- Base tray heating element
- Simple plumbing and electrical connections



## HPID6

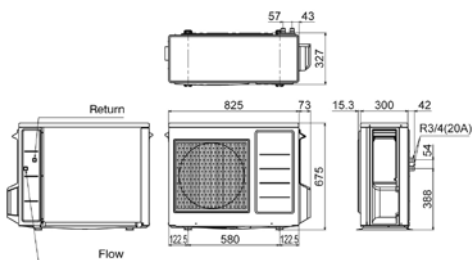

## HPID10

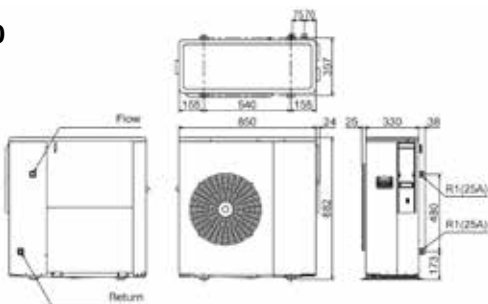

## HPID16

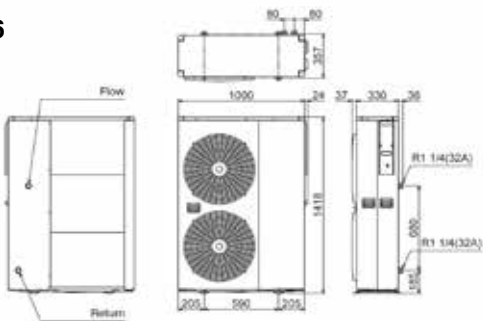

## Grant Aerona<sup>3</sup> Heat Pumps

Model		HPID6	HPID10	HPID16
ErP Rating	Heating	A++	A++	A++
	Hot Water*	A	A	A
Height (mm)		675	882	1418
Width (mm)		825	850	1000
Depth (mm)		300	330	330
Weight (kg)	Empty	53	75	121
	Full	54	77	123
Capacity (kW)		6.0	10.0	16.0
Power input (kW)		1.46	2.30	3.90
Running current (Max) (A)**		6.4 (11.2)	10.2 (17.5)	17.0 (25.3)
COP (at 7°C air/ 35°C flow)		4.11	4.35	4.10
SCOP (average climate conditions) 35°C		4.34	4.35	4.19
Refrigerant (R410A) (kg)		1.05	1.72	2.99
Operating voltage (v)		230	230	230
Flow/ return tapplings (BSPF)		3/4"	1"	1 1/4"
Min/max operating temperatures	Air (°C)	-20/43	-20/43	-20/43
Sound power level at 1m (dB(A))		63	67	63
Sound pressure level at 1m (dB(A))		40	44	40

\*When fitted with a Grant MonoWave HP 200ltr cylinder

\*\* In accordance with BS EN ISO 3744:2010

### Grant Aerona<sup>3</sup> Accessories

HPIDFOOT/KIT	Flexi-foot kit with fixings (2 x 600mm)
HPIDINSU/KIT	Through wall insulation kit to fit 22-28mm flexi hose
HPDHWBK2	Automatic domestic hot water boost kit (timed)
HPIDBUFFER50	50 Litre Buffer Tank

### Grant Aerona<sup>3</sup> Sealed System Kits

HPAWSSK12	12 Litre sealed system kit for Aerona ASHP
HPAWSSK18	18 Litre sealed system kit for Aerona ASHP
HPAWSSK50	50 Litre sealed system kit for Aerona ASHP



◀ Aerona<sup>3</sup> Flexi-foot kit  
HPIDFOOT/KIT

Aerona<sup>3</sup> Insulation kit ▶  
HPIDINSU/KIT



# Grant VortexAir Oil Boiler/ ASHP Hybrid



- Designed by Grant
- 15-21kW or 21-26kW blue flame oil boiler
- Heat Pump eligible for the RHI
- Boiler works as a stand alone unit and can be purchased separately from the heat pump
- Boiler can be fitted internally or externally
- Heat pump can be fitted at a later date
- Low level balanced flue kit included



## Grant VortexAir Hybrid

Model			HPIDAIR	HPIDAIR2
ErP Rating	Heat Pump	Heating	A++	A++
		Hot Water*	A	A
	Boiler	Heating	A	A
Height (mm)			1420	1420
Width (mm)			1790	1790
Depth (mm)			471	471
Weight (kg)	Heat Pump	Empty	121	121
	Boiler	Empty	149	151
	Combined	Empty	280	282
Boiler Output (kW)			15 - 21	21 - 26
Heat Pump Capacity (kW)			16.0	16.0
Heat Pump Power input (kW)			3.90	3.90
Heat Pump Running current (Max) (A)**			17.0 (25.3)	17.0 (25.3)
Heat Pump COP (at 7°C air/ 35°C flow)			4.10	4.10
Heat Pump SCOP (average climate conditions) 35°C			4.19	4.19
Heat Pump Refrigerant (R410A) (kg)			2.99	2.99
Heat Pump Operating voltage (v)			230	230
Heat Pump Flow/ return tappings (BSPF)			1 1/4"	1 1/4"
Heat Pump Min/max operating temperatures		Air (°C)	-20/43	-20/43
Heat Pump Sound power level at 1m (dB(A))			63	63
Heat Pump Sound pressure level at 1m (dB(A))*			37	37

\* When fitted with a Grant MonoWave HP 200ltr cylinder

\*\* In accordance with BSENISO3744:1995



## Grant VortexAir Accessories

HPIDHEATMETER	Grant VortexAir Heat Meter Kit
HPIDKW/HMETER	Grant VortexAir kW Meter
HPIDFOOT/KIT	Flexi-foot kit with fixings (2 x 600mm) *

\*requires one set for boiler (if installed externally) and one set for heat pump



Oil boiler internally (Grant plume diverter utilised for flue)



Heat Pump externally



Oil boiler combined with heat pump externally

# Grant Wave Cylinder Range



- Duplex stainless steel
- 22mm and 28mm compression fittings
- No anode required
- Immersion heater
- Labelled colour-coded tappings
- Global warming potential (GWP) = less than 3
- Ozone depletion potential (ODP) = 0



## Grant MonoWave Heat Pump Cylinders

### Unvented indirect single coil duplex stainless steel

Product Code	HPMONO/ IND125	HPMONO/ IND150	HPMONO/ IND170	HPMONO/ IND200	HPMONO/ IND200	HPMONO/ IND250	HPMONO/ IND300	HPMONO/ IND400
Capacity (ltrs)	118	136	165	188	202	222	274	356
ErP Rating	C	C	C	B	A	C	C	C
Pressure regulator (bar)	3	3	3	3	3	3	3	3
Immersion (kW)	3	3	3	3	3	3	3*	3*
Expansion vessel (ltrs)	12	12	19	19	19	24	24	35
Coil rating primary (kW)	24.0	27.0	27.0	47.0	47.0	47.0	56.6	56.6
Standing heat loss (kW/24hrs)	0.99	1.12	1.44	1.44	1.03	1.64	1.91	2.39
Height (mm)	800	890	1075	1230	1950	1480	1745	2110
Diameter (mm)	580	580	580	580	580	580	580	580
Weight empty (kg)	30	32	45	49	70	59	68	76
Weight full (kg)	155	182	215	249	270	309	368	476

\*2x 3kW immersion heaters

## Grant DuoWave Heat Pump Cylinders

### Unvented indirect twin coil duplex stainless steel

Product Code	HPDUO/ IND170	HPDUO/ IND200	HPDUO/ IND250	HPDUO/ IND300	HPDUO/ IND400
Capacity (ltrs)	163	183	216	269	350
ErP Rating	C	B	C	C	C
Pressure regulator (bar)	3	3	3	3	3
Immersion (kW)	3	3	3	3	3
Expansion vessel (ltrs)	19	19	24	24	35
Coil rating primary (kW)	32.0	47.0	47.0	55.6	55.6
Solar (kW)	8.5	10	16	16	23
Standing heat loss (kW/24hrs)	1.42	1.44	1.57	1.88	2.36
Height (mm)	1075	1230	1480	1745	2110
Diameter (mm)	580	580	580	580	580
Weight empty (kg)	57	61	71	80	100
Weight full (kg)	227	261	321	380	500

## Grant **HP MonoWave** connections

- A** Hot out
- B** T+P valve
- C** Secondary return
- D** Heat pump flow
- E** Heat pump return
- F** Thermostat pocket

- G** Immersion heater
- H** Cold In
- I** Immersion heater (300 & 400ltr models only)

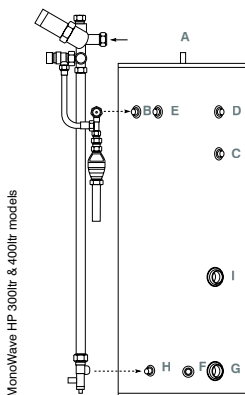
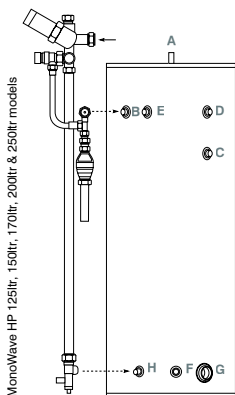

## Grant **HP DuoWave** connections

- A** Hot out
- B** T+P valve
- C** Heat pump flow
- D** Heat pump return
- E** Secondary return
- F** Thermostat pocket (top)

- G** Immersion heater
- H** Thermostat pocket (bottom)
- I** Solar flow
- J** Cold in
- K** Solar return

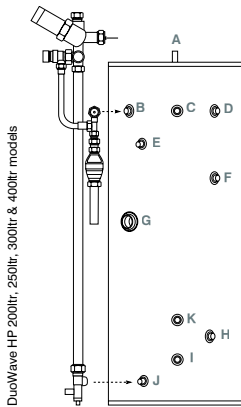
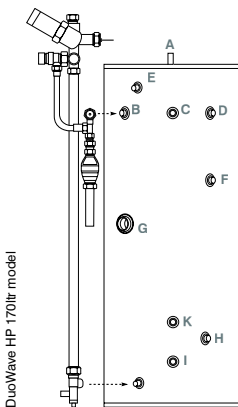

J

## Grant DuoWave Solar Cylinders

### Unvented direct solar single coil duplex stainless steel

Product Code	GDUO/ DIR170	GDUO/ DIR00	GDUO/ DIR250	GDUO/ DIR300	GDUO/ DIR400
Capacity (ltrs)	171	196	230	289	369
ErP Rating	B	C	C	C	C
Pressure regulator (bar)	3	3	3	3	3
Immersion (kW)	3	3	3	3	3
Expansion vessel (ltrs)	19	19	24	24	35
Coil rating primary (kW)	8.5	10.0	16.0	16.0	24.0
Standing heat loss (kW/24hrs)	1.40	1.53	1.71	2.09	2.49
Height (mm)	1075	1230	1480	1745	2110
Diameter (mm)	580	580	580	580	580
Weight empty (kg)	37	41	47	53	65
Weight full (kg)	207	241	297	353	465

## Grant DuoWave Solar Cylinders

### Unvented indirect solar single coil duplex stainless steel

Product Code	GDUO/ IND170	GDUO. IND200	GDUO/ IND250	GDUO/ IND300	GDUO/ IND400	GDUO/ IND500
Capacity (ltrs)	171	192	230	288	366	453.5
ErP Rating	B	C	C	C	C	D
Pressure regulator (bar)	3	3	3	3	3	3
Expansion vessel (ltrs)	19	19	24	24	35	50
Coil rating primary (kW)	8.5	8.5	8.5	8.5	10.0	16.0
Solar (kW)	8.5	10.0	13.9	16.0	24.0	27.0
Standing heat loss (kW/24hrs)	1.40	1.47	1.64	2.00	2.46	3.00
Height (mm)	1075	1230	1480	1745	2110	1835
Diameter (mm)	580	580	580	580	580	660
Weight empty (kg)	49	53	63	72	92	108
Weight full (kg)	219	253	313	372	492	608

# Grant DuoWave Solar connections

- A Hot out
- B T+P valve
- C Primary return (indirect only)
- D Secondary return
- E Top thermostat pocket (indirect only)
- F Primary flow (indirect only)
- G Solar return
- H Immersion heater (direct models only)
- I Thermostat pocket (bottom)
- J Cold mains in
- K Solar flow
- L Immersion heater



DuoWave Solar Cylinder

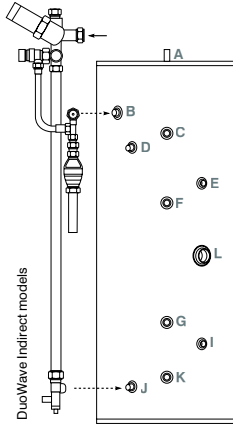
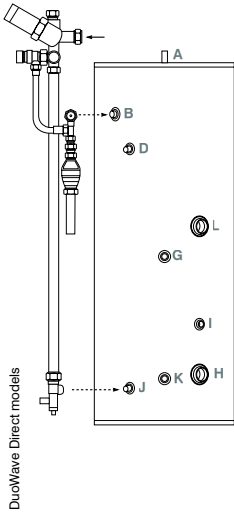

## Grant DuoWave Plus Solar Cylinders

Open vented indirect solar triple coil duplex stainless steel

Product Code	GDUO/PLUS300
Capacity (ltrs)	282
ErP Rating	C
Coil rating primary (kW)	11.6
Coil rating secondary (kW)	8.5
Solar (kW)	16
Standing heat loss (kW/24hrs)	2.21
Height (mm)	1745
Diameter (mm)	580
Weight empty (kg)	57
Weight full (kg)	357

## Grant DuoWave Plus Solar Cylinders

Unvented indirect solar triple coil duplex stainless steel

Product Code	GDUO/PLUS300U
Capacity (ltrs)	
ErP Rating	C
Pressure regulator (bar)	3
Expansion vessel (ltrs)	24
Coil rating primary (kW)	11.6
Coil rating secondary (kW)	8.5
Solar (kW)	16
Standing heat loss (kW/24hrs)	2.21
Height (mm)	1745
Diameter (mm)	580
Weight empty (kg)	57
Weight full (kg)	357

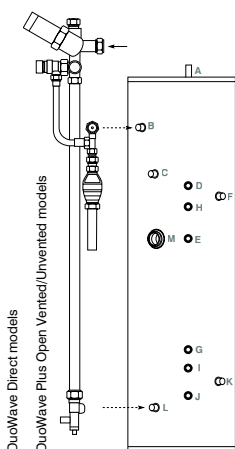

## Grant DuoWave Plus connections

- A** Hot out
- B** T+P valve
- C** Secondary return
- D** Primary return
- E** Solid fuel flow
- F** Thermostat pocket (top)
- G** Solid fuel return
- H** Primary flow
- I** Solar return
- J** Solar flow
- K** Thermostat pocket (bottom)
- L** Cold mains in
- M** Immersion heater

## Grant ThermaWave Stores

### Open vented duplex stainless steel thermal stores

Product Code	G THERM/250	G THERM/300	G THERM400
Capacity (ltrs)	234	289	373
ErP Rating	C	C	C
Coil rating solar (kW)	16	16	24
Standing heat loss (kW/24hrs)	2.69	2.71	2.94
Height (mm)	1485	1735	2110
Diameter (mm)	580	580	580
Weight empty (kg)	55	61	74
Weight full (kg)	305	361	474

### DHW Sealed system duplex stainless steel thermal stores c/w hot water coil

Product Code	G THERM300HWU	G THERM400HWU	G THERM500HWU
Capacity (ltrs)	273	369	444
ErP Rating	C	C	D
Coil rating solar (kW)	16	27.6	27.6
Coil rating DHW (kW)	46.4	55.2	55.2
Standing heat loss (kW/24hrs)	2.64	2.83	2.98
Height (mm)	1650	1590	1835
Diameter (mm)	555	660	660
Weight empty (kg)	65	80	87
Weight full (kg)	365	480	587

### DHW Open vented duplex stainless steel thermal stores c/w hot water coil

Product Code	G THERM300HW	G THERM400HW	G THERM500HW
Capacity (ltrs)	273	369	444
ErP Rating	C	C	D
Coil rating solar (kW)	16	27.6	27.6
Coil rating DHW (kW)	46.4	55.2	55.2
Standing heat loss (kW/24hrs)	2.64	2.83	2.98
Height (mm)	1650	1590	1835
Diameter (mm)	555	660	660
Weight empty (kg)	65	80	87
Weight full (kg)	365	480	587

# Grant **ThermaWave** typical connections

- A** Output seven (e.g to DHW kit or flow to DHW cylinder + OSV)
- B** T&P Valve (1/2" BSPF for 250L & 300L and 3/4" for 400L & 500L models) **C**
- Input one (e.g flow from boiler if DHW is fitted)
- D** Output one (e.g CH flow if no DHW is fitted)
- E** Thermostat pocket
- F** Input two (e.g flow from boiler if no DHW is fitted)
- G** Output two (e.g CH flow if DHW is fitted)
- G\*** Output two alternative position (e.g. if less DHW is required)
- H** 28mm gravity flow (e.g solid fuel)
- I** Input three (e.g return from DHW kit or cylinder)
- J** Output three (e.g to UFH if high capacity)
- K** Immersion heater
- L** Thermostat pocket
- M** Input four (e.g flow from heat pump)
- N** Output four (e.g return to boiler)
- O** 28mm gravity return (e.g solid fuel)
- P** Input five (e.g return from CH)
- Q** Output five (e.g UFH flow if low capacity)
- R** Solar coil return
- S** Immersion heater
- T** Thermostat pocket
- U** Solar coil flow
- V** Input six (e.g return from UFH)
- W** Output six (e.g return to heat pump)
- X** 22mm fill and drain point
- AA** Cold mains
- BB** DHW out

**Note:** The inputs and outputs highlighted above may vary depending upon the technologies being connected to the thermal store, and if a nominal quantity of domestic hot water is also required. For further guidance consult the installation manual or Grant Technical Services.

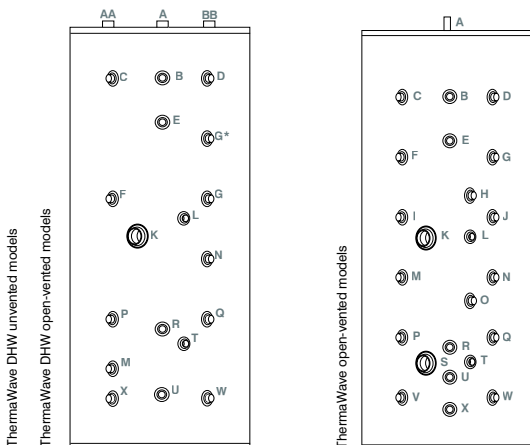



## Grant ThermaWave DHW Stores Performance Data

Capacity (ltrs)	273	369	444
Draw off 1* (20l/min at 70°C)	115	145	175
Reheat time (mins)	11	12	14
Draw off 2* (20l/min at 70°C)	230	285	355
Reheat time (mins)	20	22	24
Draw off 3* (20l/min at 70°C)	400	420	455
Reheat time (mins)	28	32	35

Note: Draw off provides a final mixed water temperature (e.g. for bath) of 45°C. Draw off 1 is the top third of the store. Draw off 2 is the top 2/3 of the store. Draw off 3 is the full store (without solar thermal input). Reheat times relate to raising the same volume of water back to 70°C.

## Grant **ThermaWave** DHW components

### Open Vented Models

- 1ltr shock arrestor
- 22mm thermostatic mixing valve
- 22mm x 22mm 1/2" BSPF fitting
- 3 bar/6bar inlet group (optional extra)

### Sealed System Models

- 1 ltr shock arrestor
- 22mm thermostatic mixing valve
- 22mm x 22mm 1/2" BSPF fitting
- 3 bar/6bar inlet group (optional extra)
- Expansion vessel
- Expansion vessel bracket/hose
- Reducer fitting (400/500ltr models only)
- 22mm x 22mm x 3/4" BSPF fitting
- 1/2" BSPM to 15mm fitting (90°)
- Filling loop kit
- PRV & Pressure gauge
- 80°C limit stat
- Electrical control box

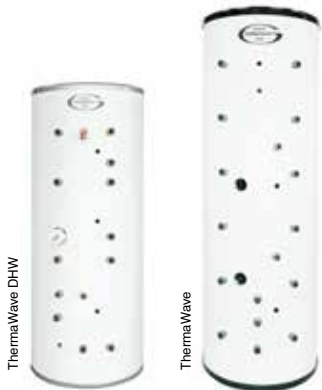

# Grant Solar Thermal Range



- Available in kits
- High efficiency flat plate collector
- Multifunctional controller
- In-roof, on-roof & flat roof options
- New compact pump station
- Solar Keymark approved



Collector Information	
Length (mm)	2043
Width (mm)	1143
Depth (mm)	80
Collector gross area (m <sup>2</sup> )	2.34
Aperture/absorber area (m <sup>2</sup> )	2.14
Weight (kg)	40
Glass type	ESG, Durasolar P+ Sandy
Glass Thickness (mm)	3.2
Efficiency (%)	82.6
Effective thermal capacity(KJ/m <sup>2</sup> K <sup>2</sup> )	12620
Conversion factor ( $\eta_c$ )	0.826
Linear heat loss coefficient ( $a_1$ )	4.4
Linear heat loss coefficient ( $a_2$ ) (W/m <sup>2</sup> K <sup>2</sup> )	0.008
Stagnation temperature* (°C)	177
Maximum operating pressure (bar)	10
Fluid content (litr)	1.6
Tilt angle (maximum/minimum) (°)	20/90
Pressure drop (at 2.5l/min solar fluid) (mbar)	105

\*Test conditions - Irradiance 1000W/m<sup>2</sup> Ambient temperature 30°C

## Solar irradiation in the UK and Ireland

The diagram below shows the total average solar radiation falling on 1m<sup>2</sup> surface, inclined at 30° to the horizontal, measured in kilowatt-hours. The average property requires approximately 3,000 kWh per year for domestic water heating.

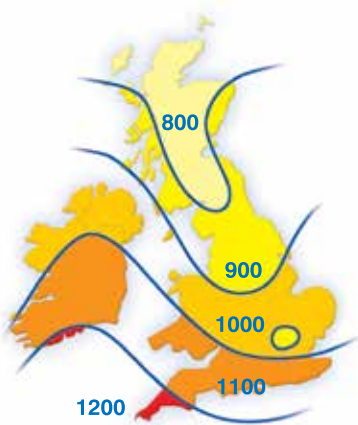

### How to calculate the number of collectors required

Direction of roof	Solar radiation (see above map) kWh/year	Number of people per household			
		<3	4	5	6
South	900 - 1000	2	2	2	3
	1000 - 1100	2	2	2	2
	1100 - 1200	2	2	2	2
South west/ South East	900 - 1000	2	2	3	3
	1000 - 1100	2	2	2	3
	1100 - 1200	2	2	2	2
West	900 - 1000	2	3	3	4
	1000 - 1100	2	2	3	3
	1100 - 1200	2	2	2	3
East	900 - 1000	2	3	3	4
	1000 - 1100	2	3	3	3
	1100 - 1200	2	2	2	3

Cylinder requirements are 50-60 litres capacity per m<sup>2</sup> of nett collector area. To simplify this, for a 2-collector system of  $2 \times 2.14 = 4.28\text{m}^2$ , you would require a cylinder of approximately 200-250 litres. This should be sufficient for 4 people and satisfy up to 70% of your hot water demand per annum.

## SAHARA Portrait Kits (On-Roof Mounting Options)

<b>GSSKIT0</b> 1 Collector Bronze On-Roof	QTY	Product Code
Solar Collector (Bronze)	1	GS222773
Connection kit flow and return	1	GS222146
1 Collector on roof extra set	1	GS222742
Pump Station	1	GS222154H
Controller	1	GS222765
Solar Fluid 20 litre	1	GS222076
Expansion Vessel 18 litre	1	GS222071
Expansion Vessel pipe connections	1	GS222074
Expansion Vessel bracket and valve	1	GS222073
<b>Roof Anchors:</b>		
Anchors for profile tile (Pack of 2)	2 Pks*	GS222148
Anchors for flat tile (Pack of 2)	2 Pks*	GS222088
Anchors for slate tile (Pack of 2)	2 Pks*	GS222090

<b>GSSKIT1</b> 2 Collector Bronze On-Roof	QTY	Product Code
Solar Collector (Bronze)	2	GS222773
Connection kit flow and return	1	GS222146
Connection Kit collector to collector	1	GS222068
2 Collector portrait rails and fixings	1	GS222741
Pump Station	1	GS222154H
Controller	1	GS222765
Solar Fluid 10 litre	1	GS222075
Solar Fluid 20 litre	1	GS222076
Expansion Vessel 18 litre	1	GS222071
Expansion Vessel pipe connections	1	GS222074
Expansion Vessel bracket and valve	1	GS222073
<b>Roof Anchors:</b>		
Anchors for profile tile (Pack of 2)	3 Pks*	GS222148
Anchors for flat tile (Pack of 2)	3 Pks*	GS222088
Anchors for slate tile (Pack of 2)	3 Pks*	GS222090

<b>GSSKIT2</b> 3 Collector Bronze On-Roof	QTY	Product Code
Solar Collector (Bronze)	3	GS222773
Connection kit flow and return	1	GS222146
Connection Kit collector to collector	2	GS222068
2 Collector portrait rails and fixings	1	GS222741
1 Collector on roof extension kit	1	GS222742
Pump Station	1	GS222154H
Controller	1	GS222765
Solar Fluid 20 litre	2	GS222076
Expansion Vessel 18 litre	1	GS222071
Expansion Vessel pipe connections	1	GS222074
Expansion Vessel bracket and valve	1	GS222073
<b>Roof Anchors:</b>		
Anchors for profile tile (Pack of 2)	4 Pks*	GS222148
Anchors for flat tile (Pack of 2)	4 Pks*	GS222088
Anchors for slate tile (Pack of 2)	4 Pks*	GS222090

\*This is the minimum number of roof anchors required. For MCS compliant installations the number of roof anchors must be calculated using the method given in MCS012

## SAHARA Portrait Kits (In-roof Mounting Options)

<b>GSSKIT15</b> 1 Collector Bronze In-Roof (TILE)	QTY	Product Code
Solar Collector (Bronze)	1	GS222773
Connection kit flow and return	1	GS222146
1 Collector Portrait In-Roof Kit - Tile Roof	1	GS255247 + GS255245
Pump Station	1	GS222154H
Controller	1	GS222765
Solar Fluid 20 litre	1	GS222076
Expansion Vessel 18 litre	1	GS222071
Expansion Vessel pipe connections	1	GS222074
Expansion Vessel bracket and valve	1	GS222073

<b>GSSKIT16</b> 1 Collector Bronze In-Roof (SLATE)	QTY	Product Code
Solar Collector (Bronze)	1	GS222773
Connection kit flow and return	1	GS222146
1 Collector Portrait In-Roof Kit - Slate Roof	1	GS255249 + GS255245
Pump Station	1	GS222154H
Controller	1	GS222765
Solar Fluid 20 litre	1	GS222076
Expansion Vessel 18 litre	1	GS222071
Expansion Vessel pipe connections	1	GS222074
Expansion Vessel bracket and valve	1	GS222073

<b>GSSKIT3</b> 2 Collector Bronze In-Roof (TILE)	QTY	Product Code
Solar Collector (Bronze)	2	GS222773
Connection kit flow and return	1	GS222146
Connection Kit collector to collector	1	GS222068
2 Collector Portrait In-Roof Kit - Tile Roof	1	GS255246 + GS255244
Pump Station	1	GS222154H
Controller	1	GS222765
Solar Fluid 10 litre	1	GS222075
Solar Fluid 20 litre	1	GS222076
Expansion Vessel 18 litre	1	GS222071
Expansion Vessel pipe connections	1	GS222074
Expansion Vessel bracket and valve	1	GS222073

<b>GSSKIT17</b> 2 Collector Bronze In-Roof (SLATE)	QTY	Product Code
Solar Collector (Bronze)	2	GS222773
Connection kit flow and return	1	GS222146
Connection Kit collector to collector	1	GS222068
2 Collector Portrait In-Roof Kit - Slate Roof	1	GS255248 + GS255244
Pump Station	1	GS222154H
Controller	1	GS222765
Solar Fluid 10 litre	1	GS222075
Solar Fluid 20 litre	1	GS222076
Expansion Vessel 18 litre	1	GS222071
Expansion Vessel pipe connections	1	GS222074
Expansion Vessel bracket and valve	1	GS222073

<b>GSSKIT4</b> <b>3 Collector Bronze In-Roof (TILE)</b>	QTY	Product Code
Solar Collector (Bronze)	3	GS222773
Connection kit flow and return	1	GS222146
Connection kit connector to connector	2	GS222068
2 Collector portrait In-Roof kit - Tile Roof	1	GS255246 + GS255244
1 Collector portrait In-Roof extension - Tile Roof	1	GS255251 + GS255245
Pump Station	1	GS222154H
Controller	1	GS222765
Solar Fluid 20 litre	2	GS222076
Expansion Vessel 18 litre	1	GS222071
Expansion Vessel pipe connections	1	GS222074
Expansion Vessel bracket and valve	1	GS222073

<b>GSSKIT18</b> <b>3 Collector Bronze In-Roof (SLATE)</b>	QTY	Product Code
Solar Collector (Bronze)	3	GS222773
Connection kit flow and return	1	GS222146
Connection kit connector to connector	2	GS222068
2 Collector portrait In-Roof kit - Slate Roof	1	GS255248 + GS255244
1 Collector portrait In-Roof ext - Slate Roof	1	GS255245 + GS255250
Pump Station	1	GS222154H
Controller	1	GS222765
Solar Fluid 20 litre	2	GS222076
Expansion Vessel 18 litre	1	GS222071
Expansion Vessel pipe connections	1	GS222074
Expansion Vessel bracket and valve	1	GS222073

### **SAHARA Portrait Kits (Flat-roof Mounting Options)**

<b>GSSKIT5</b> <b>2 Collector Bronze Flat-Roof</b>	QTY	Product Code
Solar Collector (Bronze)	2	GS222773
Connection kit flow and return	1	GS222146
Connection Kit collector to collector	1	GS222068
2 Collector portrait Flat Roof rails & fixings	1	GS222741
2 Collector portrait Flat Roof Kit	1	GS222028
2 Collector portrait Flat Roof Cruciform	1	GS222169
Pump Station	1	GS222154H
Controller	1	GS222020
Solar Fluid 10 litre	1	GS222075
Solar Fluid 20 litre	1	GS222076
Expansion Vessel 18 litre	1	GS222071
Expansion Vessel pipe connections	1	GS222074
Expansion Vessel bracket and valve	1	GS222073

For bespoke kits please contact our sales team on  
+44 (0)1380 736920



## Grant **CombiSOL**

- Designed by Grant
- Compatible with most combination boilers
- Accurately regulates inlet water temperature

Product Code	Description
COMSOL3	Thermostatic Solution for linking Combi boilers to Solar Thermal pre-heat cylinders

## Grant **WinterSOL**



- Designed by Grant
- Provides a fully heated cylinder of hot water at times of low solar gain
- Operates during programmed hot water periods

Product Code	Description
WINTERSOL1	Recirculating/ Sanitising solution (heats complete solar cylinder when there is no solar gain)

# Grant **Vecta Internal** Wood Pellet Boiler Range



- Highly efficient
- MCS approved
- Top fill 60kg integrated pellet store with optional 140kg bolt on side pellet store
- Automatic pellet feed and ignition
- Award winning product
- Automatic wash system for condensing unit
- Self-cleaning system for heat exchanger and burner brazier
- Simple to install and maintain
- Optional remote logo indicator kit
- Exceptionally quiet
- Factory fitted Lambda sensor
- Nett efficiency:
  - Part load (condensing): 97.5%
  - Full load (condensing): 101.5%
- Exempt under the Clean Air Act



Vecta Condensing Wood Pellet Boilers	
Internal white cased model	
Product Code	WVP4/16
Boiler Output (kW)	4 -16
Boiler Weight (empty) (kg)	255
Boiler Weight (full) (kg)	350*
Flue (mm)	125
Wash system (condensing unit) (mm)	15
Flow/return connection (mm)	22
Condensate drain	1 1/4" female
Water content (litres)	35
Electrical supply	~230V 1ph 50Hz 5A fused
Integrated hopper size (kg)	60

\*including water content and full hopper



# Boiler Dimensions

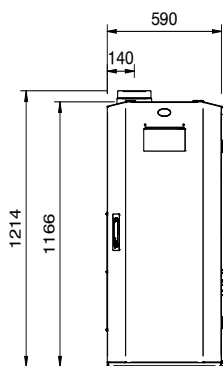

Front view

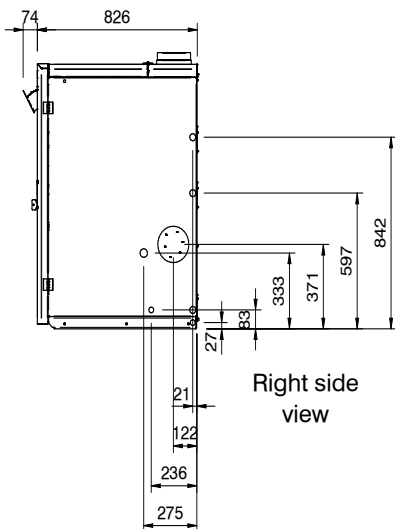

Right side view

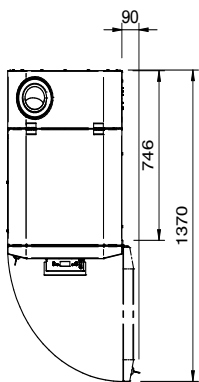

Top view

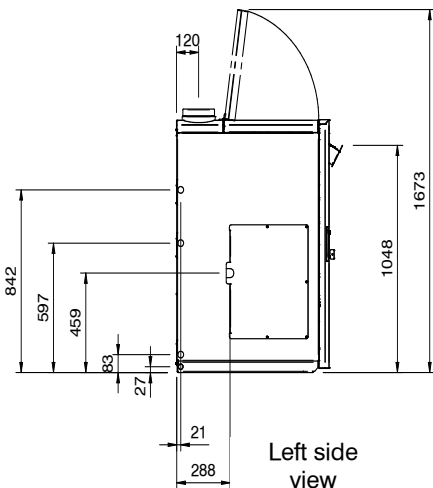

Left side view

# Grant **Vecta External** Wood Pellet Boiler Range



- Highly efficient
- Top fill 80kg integrated pellet store with optional 140kg bolt on side pellet store
- Weather proof powder coated finish
- Includes remote logo indicator kit
- Automatic pellet feed and ignition
- Automatic wash system for condensing unit
- Self-cleaning system for heat exchanger and burner brazier
- Simple to install and maintain
- Factory fitted Lambda sensor
- Nett efficiency:
  - Part load (condensing): 97.5%
  - Full load (condensing): 101.5%
- Exempt under the Clean Air Act



Vecta Condensing Wood Pellet Boilers	
External powder coated module	
Product Code	WVP4/16EXT
Boiler Output (kW)	4 -16
Boiler Weight (empty) (kg)	265
Boiler Weight (full) (kg)	380*
Flue (mm)	125
Wash system (condensing unit) (mm)	15
Flow/return connection (mm)	22
Condensate drain	1 1/4" female
Water content (litres)	35
Electrical supply	~230V 1ph 50Hz 5A fused
Integrated hopper size (kg)	80

\*including water content and full hopper

# Boiler Dimensions

---

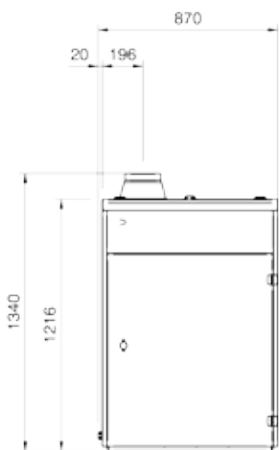

Front view

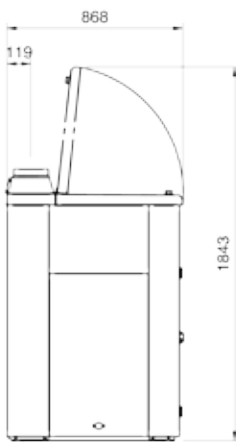

Left view

Top view

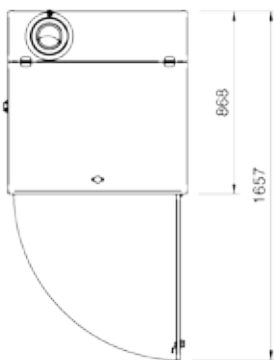

# Grant Vecta Internal Side Pellet Store



- 140kg capacity
- White casing
- Fits to the right hand side of the boiler (only)
- Top fill via hinged lid with gas struts
- Comes complete with feed auger and cable
- Combined pellet storage capacity (boiler + side store) of 200kg

Optional Vecta Internal Side Pellet Store	
Product Code	WVP4/16STORE
Capacity	140kg
Height (mm)	1162
Height with open lid (mm)	1670
Width (mm)	650
Width (including boiler) (mm)	1240
Depth (mm)	826
Weight (empty) (kg)	96kg
Weight (full)	236kg

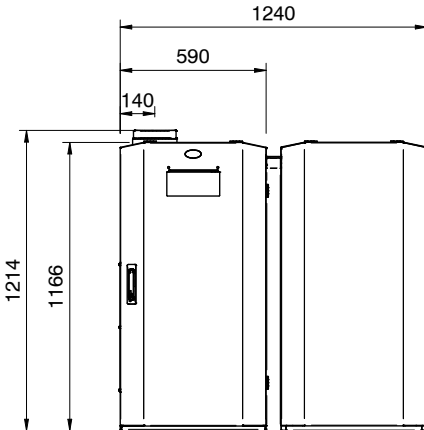

# Grant Vecta External Side Pellet Store



- 140kg capacity
- Powder coated stainless steel casing
- Fits to the right hand side of the boiler (only)
- Top fill via hinged lid with gas struts
- Comes complete with feed auger and cable
- Combined pellet storage capacity (boiler + side store) of 220kg
- Supplied with weather proof external flue system inspection pipe

## Optional Vecta Internal Side Pellet Store

Product Code	WVP4/16EXTSTORE
Capacity	140kg
Height (mm)	1216
Height with open lid (mm)	1843
Width (mm)	682
Width (including boiler) (mm)	1552
Depth (mm)	793
Weight (empty) (kg)	80
Weight (full)	220

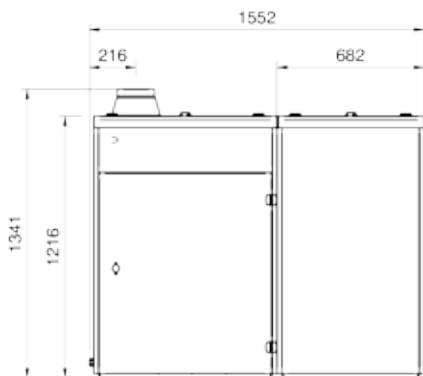

# Grant **Spira** Wood Pellet Boiler Range



- Highly efficient condensing boiler
- MCS approved
- Modulating burner
- Integrated pellet store
- 125mm conventional flue
- Automatic pellet feed and ignition
- Award winning condensing heat exchanger
- Flue box with integral fan/ draught stabiliser
- Automatic wash system for condensing unit
- Exempt under the Clean Air Act



## Internal Standard Models Including Pellet Store and Auger(s)

Product Code	Output		Description
	Btu/h x1000	KW	
WPS518RH110	17-60	5-18	18kW wood pellet boiler c/w 110kg right hand hopper & auger
WPS518LH110	17-60	5-18	18kW wood pellet boiler c/w 110kg left hand hopper & auger
WPS518RH200	17-60	5-18	18kW wood pellet boiler c/w 200kg right hand hopper & auger
WPS518LH200	17-60	5-18	18kW wood pellet boiler c/w 200kg left hand hopper & auger
WPS626RH110	20-90	6-26	26kW wood pellet boiler c/w 110kg right hand hopper & auger
WPS626LH110	20-90	6-26	26kW wood pellet boiler c/w 110kg left hand hopper & auger
WPS626RH200	20-90	6-26	26kW wood pellet boiler c/w 200kg right hand hopper & auger
WPS626LH200	20-90	6-26	26kW wood pellet boiler c/w 200kg left hand hopper & auger
WPS936RH110	30-123	9-36	36kW wood pellet boiler c/w 110kg right hand hopper & auger
WPS936LH110	30-123	9-36	36kW wood pellet boiler c/w 110kg left hand hopper & auger
WPS936RH200	30-123	9-36	36kW wood pellet boiler c/w 200kg right hand hopper & auger
WPS936LH200	30-123	9-36	36kW wood pellet boiler c/w 200kg left hand hopper & auger
WPS12/52	40-180	12-52	2 x 26kW wood pellet boilers c/w 140kg dual hopper & augers
WPS15/62	50-213	15-62	26kW & 36kW wood pellet boilers c/w 140kg dual hopper & augers
WPS18/72	60-246	18-72	2 x 36kW wood pellet boilers c/w 140kg dual hopper & augers

	Units	Spira Model		
		5-18	6-26	9-36
Maximum heat output	kW	18	26	36
	Btu/hr	61,400	88,700	122,800
Flow connection	BSP	1" F	1" F	1 1/4" F
Return connection	BSP	1" F	1" F	1 1/4" F
Water content	Ltr	51.5	51.5	60
Waterside resistance $\Delta T = 10^{\circ}\text{C}$	mbar	50		
Waterside resistance $\Delta T = 20^{\circ}\text{C}$	mbar	40		
Mains water (cleaning system)	bar	1 bar operating pressure		
Condensate connection	-	1 1/4" BSP Female		
Conventional flue	-	125mm (5")		
Combustion chamber draught requirement	mbar	0.10 to 0.15 (running)		
Maximum static head	m	25		
Minimum circulating head	m	1		
Boiler temperature set point range	$^{\circ}\text{C}$	55 to 75		
Boiler temperature cut out point	$^{\circ}\text{C}$	65 to 80		
Minimum return temperature	$^{\circ}\text{C}$	40		
Water system overheat thermostat cut-out	$^{\circ}\text{C}$	100		
Burn-back overheat thermostat cut-out	$^{\circ}\text{C}$	90		
Electricity supply	-	~230V 1ph 50Hz 13A fused		
Max operating pressure - sealed system	bar	2.0		
Max operating pressure - open system	bar	2.0		
Maximum auger length (bulk hopper)	m	6.0		
Maximum auger speed (bulk hopper)	rpm	30		
Minimum flue length	m	1.6		
Maximum flue length	m	12.0		
Heating element rating	Watts	450		
Intermediate auger motor power	Watts	55		
Intermediate auger motor starting current	Amps	0.64		
Intermediate auger motor running current	Amps	0.64		
Intermediate auger speed	rpm	8.1		
Flue fan motor power	Watts	32		
Flue fan motor starting current	Amps	0.27		
Flue fan motor running current	Amps	0.13		
Cleaning solenoid power	Watts	10		
Cleaning solenoid current	Amps	0.087		
Burner fan motor power	Watts	56		
Total burner start current	Amps	2.5		
Total burner run current	Amps	0.60		

# Single Boiler Dimensions

Front view

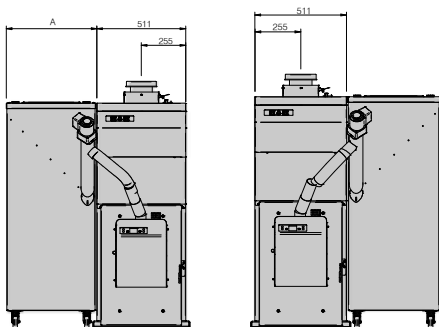

Side view

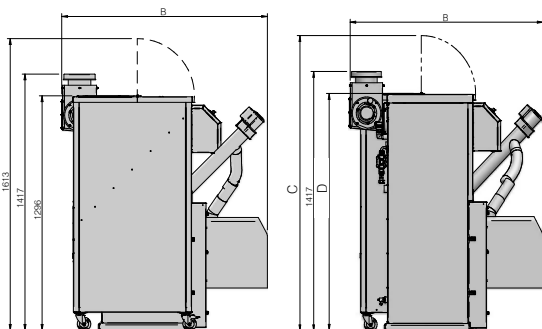

Rear view

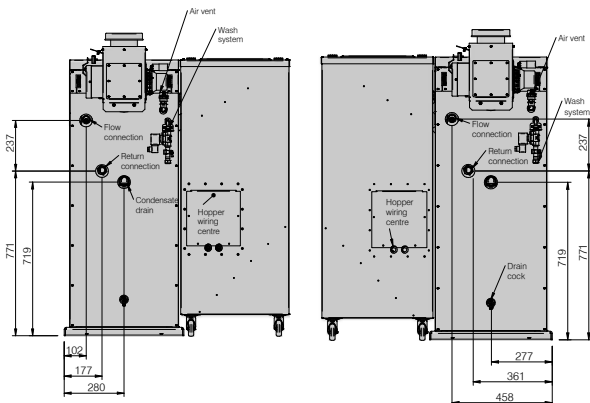

Grant Spira Model	Dimensions (mm)			
	A	B	C	D
5-18kW 110kg left/right hand hopper	518	1120	1613	1293
5-18kW 200kg left/right hand hopper	618	1120	1813	1493
6-26kW 110kg left/right hand hopper	518	1120	1613	1293
6-26kW 200kg left/right hand hopper	618	1120	1813	1493
9-36kW 110kg left/right hand hopper	518	1220	1613	1293
9-36kW 200kg left/right hand hopper	618	1220	1813	1493



# Double Boiler Dimensions

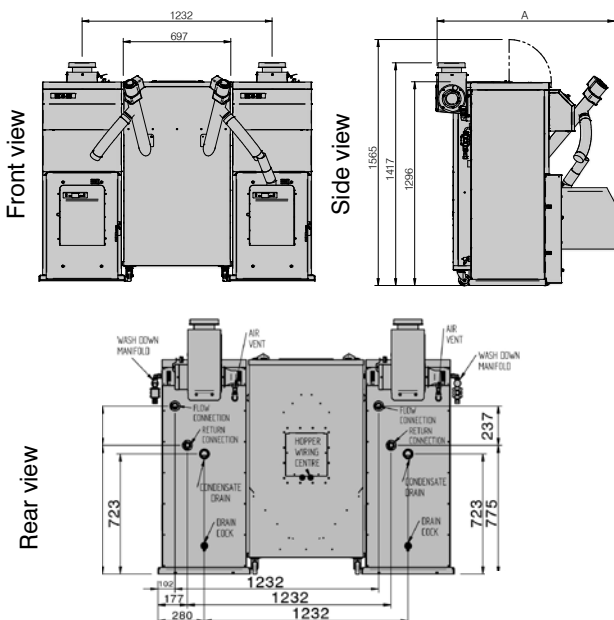

Grant Spira Model	Dimensions (mm)
	A
12-52KW 140kg double hopper	1120
15-62kW 140kg double hopper	1220
18-72kW 140kg double hopper	1220

Boiler and Hopper Weights (kg)	Spira model	
	5-18 & 6-26	9-36
Boiler - less burner & fan box (empty)	201	231
Burner	25.5	25.5
Fan box	5	5
Total boiler weight (empty)	231.5	261.5
Total boiler weight (full)	283	321.5
110kg pellet hopper incl auger (empty)	41.35	41.35
110kg pellet hopper incl auger (full)	151.35	151.35
200kg pellet hopper incl auger (empty)	77	77
200kg pellet hopper incl auger (full)	277	277
Auger	8.35	8.35
140kg pellet hopper incl 2x augers (empty)	42	42
140kg pellet hopper incl 2x augers (full)	182	182

# Grant **Biomass Flue** System

## Conventional stainless steel vertical flue

- Twist-lock bayonet jointing system
- Suitable for Spira and Vecta boilers
- Stainless steel white or black finish
- Advanced corrosion resistant design

Product Code	Finish	Description
WPW/30	WHITE	30° bend
WPW/45	WHITE	45° bend
WPW/ADJ250	WHITE	75-250mm adjustable extension c/w locking band and gasket
WPW/EXT200	WHITE	200mm extension c/w locking band and gasket (effective length 160mm)
WP/WEXT333	WHITE	333mm extension c/w locking band and gasket (effective length 293mm)
WPW/EXT500	WHITE	500mm extension c/w locking band and gasket (effective length 460mm)
WPW/EXT1000	WHITE	1000mm extension c/w locking band and gasket (effective length 960mm)
WPW/WB60	WHITE	Wall bracket (60 mm)
WPW/WB300	WHITE	Wall bracket (300 mm)
WPW/IP	WHITE	Inspection pipe
WPW/CA	WHITE	Flue lcid to chimflex adaptor
WPW/FP	WHITE	Firestop Plate (1 piece)
WPW/SP	WHITE	Support Plate (2 pieces)
WPW/TC	WHITE	Trim Collar for Wall Sleeve (45°)
WPB/30	BLACK	30° bend
WPB/45	BLACK	45° bend
WPB/ADJ250	BLACK	75-250mm adjustable extension c/w locking band and gasket
WPB/EXT200	BLACK	200mm extension c/w locking band and gasket (effective length 160mm)
WPB/EXT333	BLACK	333mm extension c/w locking band and gasket (effective length 293mm)
WP/BEXT500	BLACK	500mm extension c/w locking band and gasket (effective length 460mm)
WPB/EXT1000	BLACK	1000mm extension c/w locking band and gasket (effective length 960mm)
WPB/WB60	BLACK	Wall bracket (60 mm)
WPB/WB300	BLACK	Wall bracket (300 mm)
WPB/IP	BLACK	Inspection pipe
WPB/CA	BLACK	Flue lcid to chimflex adaptor
WPB/AP	BLACK	Anchor plate/ Chimflex adaptor
WPB/FP	BLACK	Firestop Plate (1 piece)

WPB/SP	BLACK	Support Plate (2 pieces)
WPB/CANT	BLACK	Cantilever (570mm)
WPB/GB	BLACK	Guy wire bracket
WPB/LBEXT	BLACK	Structural locking band
WPB/RC	BLACK	Rain cap
WPB/RS	BLACK	Roof support s/s band
WPB/SC	BLACK	Storm collar
WPB/TP	BLACK	Intermediate top plate
WPB/WS	BLACK	Wall support side plate
WPB/TC	BLACK	Trim Collar for Wall Sleeve (45°)

## Biomass flue accessories

WPB/SLE	Wall sleeve (45°) (also requires WPB/TC or WPW/TC x2)
WPB/UF200	Uni flashing (80 - 200mm)
WPB/PFL	Pitched lead flashing

## Conventional stainless steel flexible flue liner kits

- Flexi flue liner
- Stainless steel smooth bore liner
- Suitable for all Grant wood pellet boilers
- Easy to install

Product Code	Finish	Description
WPWKIT6/125	WHITE	6 metre 125mm liner (inc box kit)
WPWKIT8/125	WHITE	8 metre 125mm liner (inc box kit)
WPWKIT10/125	WHITE	10 metre 125mm liner (inc box kit)
WPBKIT6/125	BLACK	6 metre 125mm liner (inc box kit)
WPBKIT8/125	BLACK	8 metre 125mm liner (inc box kit)
WPBKIT10/125	BLACK	10 metre 125mm liner (inc box kit)

# Grant **SpiraPod** External Housing Range



- Purpose built external housing for the Spira
- Accommodates all Spira models from 5-36kW
- Designed and manufactured by Grant
- Fully weather proof steel casing
- Iconic 'Grant grey' powder coated finish
- Top fill integral hopper with 190kg capacity
- Suitable for vacuum feed
- Optional internal pellet vacuum system
- Lockable doors
- Sealed system kit can be fitted within the pod



SpiraPod Outdoor Boiler Housing	
Product Code	Description
WPSPOD18	SpiraPod 5-18kW wood pellet boiler and external casing
WPSPOD26	SpiraPod 6-26kW wood pellet boiler and external casing
WPSPOD36	SpiraPod 9-36kW wood pellet boiler and external casing



# Grant **SpiraVac** Wood Pellet Vacuum



- Designed and manufactured by Grant
- Simple to install
- Gives more flexibility with boiler installation
- Can be retrofitted to existing boiler
- Maximum hose length of 20m
- Lifts pellets up to a height of 3m
- Only for use with the Grant Spira boiler ranges

## Grant SpiraVac Models

Code	Description
WPV/KIT5INT	SpiraVac Internal Spira Vacuum kit - 5 metres
WPV/KIT10INT	SpiraVac Internal Spira Vacuum kit - 10 metres
WPV/KIT15INT	SpiraVac Internal Spira Vacuum kit - 15 metres
WPV/KIT20INT	SpiraVac Internal Spira Vacuum kit - 20 metres
WPV/KIT5POD	SpiraVac SpiraPod Vacuum kit - 5 metres
WPV/KIT10POD	SpiraVac SpiraPod Vacuum kit - 10 metres
WPV/KIT15POD	SpiraVac SpiraPod Vacuum kit - 15 metres
WPV/KIT20POD	SpiraVac SpiraPod Vacuum kit - 20 metres

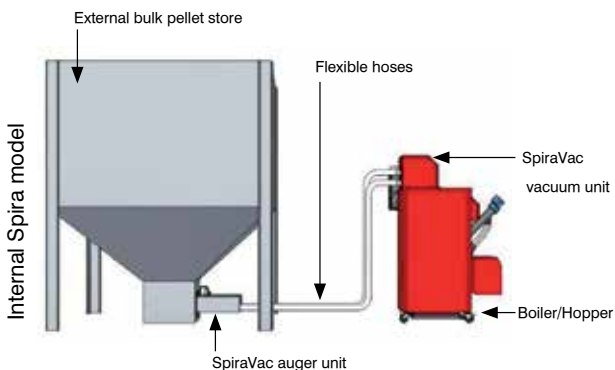

# Grant **Wood Pellet Store** Range



- Designed and manufactured by Grant
- Galvanised steel construction
- Quick seal joints
- Universal auger or vacuum connection
- Internal or external installation
- Low level connection for ease of filling
- Extremely robust construction
- Easy access maintenance door for cleaning

**Grant Pellet Store Models**

Code	Size (tonne)	Finish	Footprint (metre)	Height (mm)	Weight (kg)
WPXG05TP	0.5	Painted	1 x 1	1375*	70
WPXG075TP	0.75	Painted	1 x 1	1715*	83
WPXG15T	1.5	Galvanised	2 x 1	2395	310
WPXG2T	2	Galvanised	2 x 1	2700	360
WPXG25T	2.5	Galvanised	2 x 1	2900	375
WPXG3T	3	Galvanised	2 x 2	2395	410
WPXG35T	3.5	Galvanised	2 x 2	2700	472
WPXG4T	4	Galvanised	2 x 2	2900	493
WPXG5T	5	Galvanised	2 x 2	3200	555
WPXG6T	6	Galvanised	2 x 2	3400	577

\*Please allow additional clearance of 450mm for store lid

Note: Not suitable for use with Grant Vecta boilers

Painted Pellet Store



- 500kg and 750kg models come ready assembled

# Grant **MagOne** Magnetic Filter



- High performance heavy duty filter
- Easy clean, easy drain design
- 12000 gauss neodymium magnet
- Full bore flat face 28mm isolation valves with 28-22mm reducers
- 120°C max working temperature
- 6 bar max working pressure
- 500ml dosing capacity
- Manual air bleed
- 360° Installation
- Suitable for systems up to 36kW, larger systems use two in parallel circuit

Product Code	Description
VM01/X	Vortex MagOne universal 22/28mm magnetic central heating filter

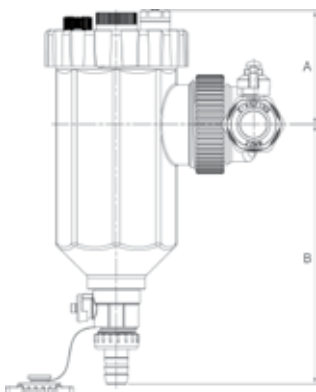

Item	Measurement (mm)	
	22mm	28mm
A	42	
B	215	
C	152	
D	85	
E	230	245

**Note:**  
Please allow enough clearance around the MagOne to ensure the isolating valves can be fully closed.

It is recommended that a clearance of at least 250mm is given to enable the magnet and filter to be removed during servicing.

Sufficient clearance must also be given to ensure that the MagOne can be drained easily into a suitable container.

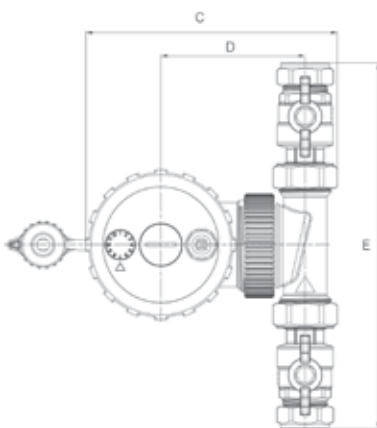

# Energy Management **Control Systems**



GEO360



GES264

- Reduces heating bills
- Easier system installation and commissioning
- Environmentally friendly
- Suitable for systems up to 165kW
- Individually controlled heat circuits
- Option to switch the system to hot water priority
- Allows a number of heating appliances to be combined, including renewable technologies
- Provides boiler lead/lag rotation, equalising appliance running time
- Maximises overall boiler/ appliance efficiency
- Tailored system concept drawings for both plumbing and wiring available

## Grant Energy Management Controllers

Product Code	Description	ErP Class		Package Uplift
		With on/off heaters	With modulating heaters	
GEO360/28	GEO360 Weather compensator with 28mm valves suitable for Vortex Pro 26-46kW, Vortex Eco 26-35kW)	With on/off heaters	VII	3.5%
		With modulating heaters	VI	4%
GEO360/35	GEO360 Weather compensator with 35mm valves (suitable for Vortex Pro 46-70kW)	With on/off heaters	VII	3.5%
		With modulating heaters	VI	4%
GEO360/KV6	GEO360 Weather compensator with KV6.3 valve (suitable for Vortex Eco 15-21kW, Eco Wallhung 12-21kW)	With on/off heaters	VII	3.5%
		With modulating heaters	VI	4%
GEO360/KV8	GEO360 Weather compensator with KV8 valve (suitable for Vortex Pro 15-26kW, Vortex Eco 21-26kW, Spira 6-36kW)	With on/off heaters	VII	3.5%
		With modulating heaters	VI	4%
GHS/GEO360	GEO360 for Grant low loss header system (no valve body)	With on/off heaters	VII	3.5%
		With modulating heaters	VI	4%
GES264	GES264 sequence controller (for 2 to 4 heat sources)	With on/off heaters	VII	3.5%
		With modulating heaters	VI	4%



## Grant Low Loss Headers (for systems up to 70kW)

Product Code	Description
GHS70/1252	1" flow and return distributor (2 zone)
GHS70/1253	1" flow and return distributor (3 zone)
GHS70/1254	1" flow and return distributor (4 zone)
GHS70/1255	1" flow and return distributor (5 zone)
GHS70/1256	1" flow and return distributor (6 zone)
GHS60/125	1 1/4" hydraulic switcher
Accessories	
GHS/WF100	Header bracket set wrap over 100mm
GHS/WF150	Header bracket set wrap over 150mm
GHS/WFHV	Header bracket set 90°
GHS05629	1 1/4" connector (quantity: 1) Please note: 2 connectors per switcher required
GHS/0266M	1" Isolation valve (quantity: 1) Please note: 2 valves per pump station required
GHS/SG50	Safety set up to 50kW (3 bar PRV) Please note: if 70kW please use GHS/SG200
Technical Specification	
Maximum flow rate	up to 3m <sup>3</sup> /h, 6bar
Insulation box	110 x 110 x 508mm (min) - 1508mm (max) (depending on model)
Pump unit connection	1" male
Hydraulic switcher connection	1 1/4" male
Side connection	3/4" female



Hydraulic switcher ((70kW) @ Δt20k)



Distributor ((70kW) @ Δt20k)

## Grant Low Loss Headers (for systems up to 165kW)

Product Code	Description
GHS80/1252	1 1/4" flow and return distributor (2 zone)
GHS80/1253	1 1/4" flow and return distributor (3 zone)
GHS80/1254	1 1/4" flow and return distributor (4 zone)
GHS80/1255	1 1/4" flow and return distributor (5 zone)
GHS80/1256	1 1/4" flow and return distributor (6 zone)
GHS80/570	2" vertical hydraulic switcher
Accessories	
GHS/WF160	Header bracket set wrap over 160mm
GHS/WFHV160	Header wall fixing set - 160mm
GHS076929	2" connection kit
GHS/55AMMS	1 1/4" isolation valve (quantity: 1) - please note: 2 valves per pump station required
GHS/HT07	2" nut & gasket for 1 1/4" isolation valves (quantity: 1) - please note: 2 sets of nut & gaskets per pump station required
GHS/SG200	Safety set up to 200kW (3 bar PRV)
Technical Specification	
Maximum flow rate	up to 7m <sup>3</sup> /h, 6bar
Insulation box	152 x 152 x 625mm (min) - 1625 (max) (depending on model)
Pump unit connection	1 1/4" male
Hydraulic switcher connection	2" male
Side connection	2" male



Distributor and hydraulic switcher



Zone pump kit (constant)

### Zone Pump Kits (for systems up to 70kW)

Product Code	Description
GHS/CT01	Constant temperature/variable speed 6 metre zone pump kit
GHS/CT02	Constant temperature/variable speed 8 metre zone pump kit
GHS/VT03	Variable temperature/variable speed 6 metre zone pump kit
GHS/VT04	Variable temperature/variable speed 8 metre zone pump kit

### Zone Pump Kits (for systems up to 165kW)

Product Code	Description
GHS/CT05	32mm constant temperature/variable speed 7 metre zone pump kit
GHS/CT06	32mm constant temperature/variable speed 8 metre zone pump kit
GHS/VT07	32mm variable temperature/variable speed 7 metre zone pump kit
GHS/VT08	32mm variable temperature/variable speed 8 metre zone pump kit

### Technical Specification

#### Zone pump kits (constant speed) Unmixed

Comprises	HE Zone pump, isolator ball valves, temperature gauges and non-return valve
Connection sizes	1" and 1 1/4" BSP
Dimensions	250 x 380 x 190mm
Maximum temperature	110°C
Application	For power up to 50kW and maximum flow 2150 l/hr
Flow	6m, 7m or 8m circulating pump

#### Zone pump kits (variable speed) Unmixed

Comprises	HE Zone pump, isolator ball valve, temperature gauges and non-return valve, 3-port mixing valve
Connection sizes	1" and 1 1/4" BSP
Dimensions	250 x 380 x 190mm
Maximum temperature	110°C
Application	For power up to 35kW and maximum flow 1500 l/hr
Flow	6m, 7m or 8m circulating pump, 3-way mixing valve for weather compensation using a Grant GEO360 Control

This leaflet is accurate at the time of printing but as Grant UK has a policy of continual improvement it may be superseded. We reserve the right to amend specifications without prior notice. The statutory rights of the consumer are not affected. All products manufactured under I.S. EN ISO 9001. Grant UK additionally holds ISO 14001 accreditation. <sup>TM</sup>THE GRANT 'EZ-FIT FLUE' SYSTEM is a trade mark of Grant Engineering Ireland ULC.

®Grant Aeron, Grant Spira, Grant Vecta, Grant Vortex, Grant VortexBlue, Grant MagOne, Grant VortexAir, Grant Solar, Grant Aurora, Grant Sahara, Grant CombiSOL, Grant WinterSOL, Grant MonoWave, Grant DuoWave, Grant ThermaWave, Euroflame and Multi Pass are registered trade marks of Grant Engineering Ireland ULC. The contents of this leaflet are fully protected by copyright and nothing may be reproduced without permission from Grant Engineering Ireland ULC.



**Grant Engineering (UK) Ltd**  
Hopton House, Hopton Industrial Estate,  
Devizes, Wiltshire, SN10 2EU

**t: +44 (0)1380 736920 f: +44 (0)1380 736991**  
**e: [info@grantuk.com](mailto:info@grantuk.com) w: [www.grantuk.com](http://www.grantuk.com)**

