

SANIFLO®

PLUMBING THE POSSIBILITIES



PUMPS & MACERATORS

2017

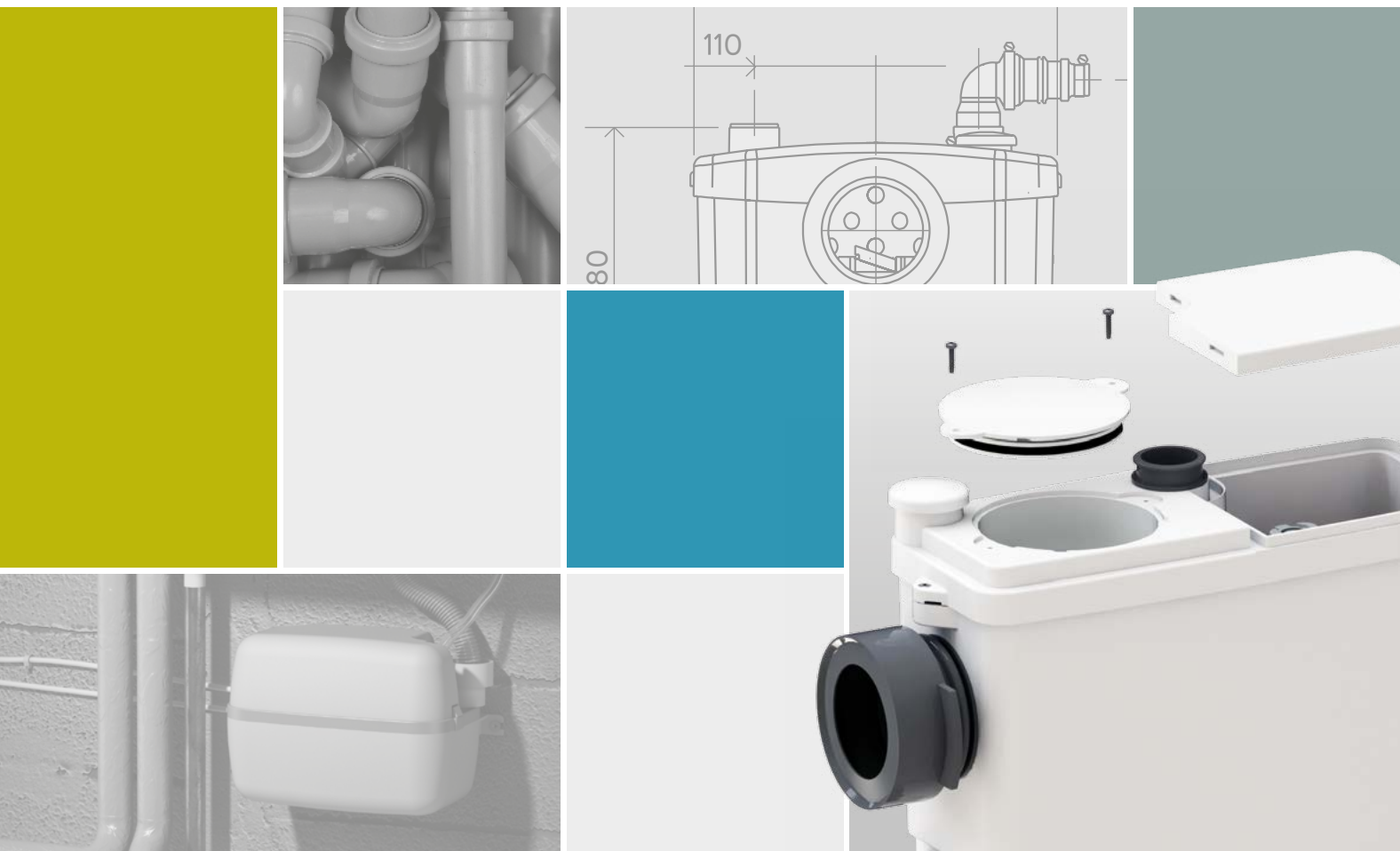

Saniflo – the facts

Saniflo macerator pumps and lifting stations reduce waste to liquid form and discharge through small-bore pipework to a soil stack or sewer.

This means real economies in labour and structural work by eliminating conventional four inch gravity discharge pipework. Saniflo units activate automatically when the cistern is flushed.

The units are quiet and economic to use and are simply connected to the domestic electrical supply, via an unswitched fused spur. The units are specifically designed for use in damp and steamy conditions and the powerful induction motors are sealed for life.

Thermal overload cut-outs are fitted to help protect them from abuse. Only the highest quality, non-corroding materials and components are used. Moving parts are minimised for maximum reliability and durability.

European standards apply to all our products in the domestic range: EN 12050-2 (Pumps) and EN 12050-3 (Domestic macerators).

All our products are designed and manufactured in France and rigorously tested in our factory. We have years of experience in the market, constantly refining and improving our technology and we are confident on their reliability.

As part of the SFA Group, Saniflo are committed to an integrated quality and environmental management system and our business and factory complies with ISO 9001 and ISO 14001.

Not sure which Saniflo unit to specify?

Lift the flap for a full ready-reference guide as to which of our units is best suited to your specific installation.



SANIFLO®
PLUMBING THE POSSIBILITIES

Saniflo Limited

Howard House, The Runway, South Ruislip
Middlesex HA4 6SE, United Kingdom

Tel 020 8842 0033 Fax 020 8842 1671 Web www.saniflo.co.uk

As our policy is one of continuous product improvement we reserve the right to alter product specification without notice. All information in this publication is given in good faith. No responsibility can be accepted for any errors, omissions or incorrect assumptions. 01/17 29671UK

PRODUCT SELECTOR

All of our units can be used in any of these situations:
Basement, Ground Floor, Upper Floor, Loft/Attic –
just choose the right product for your installation...

	WC	Wall-hung WCs	Wash Basin	Bath	Shower	Power shower	Bidet	Washing Machine	Dishwasher	Sink	Alarm ¹
SANIFLO UP Ref 6001	•										•
SANITOP UP Ref 6002	•		•								•
SANIPLUS UP Ref 6003	•		•		•	•	•				•
SANISLIM Ref 1054/1	•		•		•		•				•
SANIPACK PRO UP Ref 6052	•	•	•		•	•	•				•
SANIPRO UP Ref 6006	•	•	•		•	•	•				•
SANICOMPACT² Ref 1081	•	•	•								•
SANIWALL PRO UP Ref 6110	•	•	•		•	•	•				•
SANIVITE + Ref 6004	•		•	•				•	•	•	•
SANISHOWER + Ref 6043	•		•		•		•				•
SANISHOWER FLAT Ref 1043/3			•		•						
SANIFLOOR Ref 1154/1155/1156					•	•					
TRAYMATIC EXTERIOR Ref RD590AD/1AD/ 2AD/3AD/4AD/5AD					•						
SANIMATIC Ref 1116		•									
SANIACCESS 1 Ref 1900	•										
SANIACCESS 2 Ref 1901	•		•								
SANIACCESS 3 Ref 1902	•		•		•		•				
SANIACCESS PUMP Ref 1903			•	•	•		•	•	•	•	

	Condensing Boiler	Air Conditioning Units	Refrigeration Units
SANICONDENS BEST Ref 1082/2	•	•	•
SANICONDENS PRO Ref 1082/5	•	•	•
SANICONDENS ECO Ref 1133	•	•	•
SANINEUTRAL Ref 1082/4	•	•	•
SANICONDENS CLIM PACK Ref 1132		•	
SANICONDENS CLIM MINI Ref 1131		•	
SANICONDENS CLIM DECO Ref 1134		•	•

¹ Sanialarm can be fitted to these units if required.
² Sanicompact can be installed in locations with a minimum water supply pressure of 1.7 bar.

CONTENTS

Our product range has been divided into Domestic and Commercial categories to make it simple to find the product you're looking for, quickly and easily.



DOMESTIC			
6001	SANIFLO UP		04
6002	SANITOP UP		05
6003	SANIPLUS UP		06
1054/1	SANISLIM		07
6052	SANIPACK PRO UP		08
6006	SANIPRO UP		09
1081	SANICOMPACT		10
6110	SANIWALL PRO UP		11
6004	SANIVITE +		12
6043	SANISHOWER +		13
1043/3	SANISHOWER FLAT		14
1154/1155/1156	SANIFLOOR		15
1143/1144/1145	TRAYMATIC EXTERIOR		16
1116	SANIMATIC		17
1900/1901/1902	SANIACCESS 1, 2 & 3		18-19
1903	SANIACCESS PUMP		20



SANICONDENS			
1082/2	SANICONDENS BEST		21
1082/5	SANICONDENS PRO		22
1133	SANICONDENS ECO		23
1082/4	SANINEUTRAL		22-23
1132	SANICONDENS CLIM PACK		24
1131/1134	SANICONDENS CLIM MINI & CLIM DECO		25



ACCESSORIES			
1095	SANIAlarm		26
1085	SANIFLO CLEANSER/DESCALER		26

Our guarantee

Saniflo units are fully guaranteed for up to five years and backed by a nationwide service network of skilled and experienced engineers, see page 27.

Technical Advice / Spares: 020 8842 0033

Service Engineer Linkline: 0345 765 0011

Please phone from a landline from the unit location in order to be connected to your local service engineer.

Visit our official website www.repairs.saniflo.co.uk for a full listing of service engineers by geographical area.

Our pumping systems are designed for the disposal of normal organic waste product, water or paper. They are not intended to replace kitchen waste or sanitary waste disposal units. As our policy is one of continuous improvement we reserve the right to alter product specification and price without notice. All information in this publication is given in good faith. No responsibility can be accepted for any errors, omissions or incorrect assumptions. Illustrations are diagrammatic and should be regarded only as indicative of technical requirements. All vertical pumping distances are measured from base of unit.

Saniflo works where convention doesn't.

Because Saniflo products are perfect for unconventional situations where drainage is a problem, you'll be able to say 'yes' to your customers more often. More jobs each month and more revenue for your business.

A bath in the basement, a loo in the loft or a shower under the stairs! Wherever you need access to conventional drainage but there's none close by, Saniflo probably has a product to help you find a solution.

Having brought the macerator concept to the UK almost 40 years ago, we now have a huge range of over 30 products including macerator pumps, lifting stations and integrated sanitaryware; all designed to work with small bore pipework that's easy to install and run to the nearest soil pipe. You'll find they're now very quiet and unobtrusive in operation and with many slim-line models available; easy to hide away.

All our products are designed and manufactured in France and rigorously tested in our factory. We have a wealth of experience in the market – 55 years of continuous development and testing goes into each device – constantly refining and improving our products and we're so confident in their reliability they're **guaranteed for 2 years with an additional 3 years for our new 2017 products**. For more information on our guarantee policy please see opposite.

Saniflo UK also has a national network of over **100 service engineers** available to your customers supporting the product day in day out, meaning worry free installation for plumbers and end users.

All you need to do is think of the possibilities.

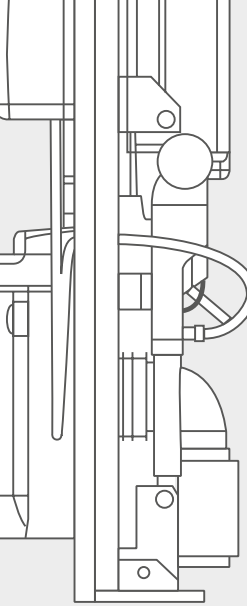

DOMESTIC

THE (R)EVOLUTION CONTINUES

SANIFLO: PLUMBING THE POSSIBILITIES SINCE 1958

- Market leader for macerators
- Sleeker designs and now even quieter
- More efficient motors (only 400W)
- Easier accessibility for simple maintenance
- 5 years Extended Warranty

OUR NEW AND IMPROVED RANGE OF DOMESTIC MACERATORS AND PUMPS HAS EVOLVED FOR A BETTER EXPERIENCE...



SANIFLO® UP
See page 04

SANIPLUS® UP
See page 06



SANITOP® UP
See page 05

SANIPRO® UP
See page 09

NEW for conventional WC installations

Easy to maintain

- Easy access lid gives improved accessibility to the tank to remove any objects
 - without disassembling the macerator
 - without emptying the tank

Quieter products

- Stronger shock absorbers: reducing vibration and noise
- The quietest macerator range on the market – 46 dB(A)

Replace an existing Saniflo macerator

- Positioning, inlet and discharge pipework remain the same
- Replaces an existing product without changing the current installation pipework

Sleeker models

- Sleeker designs that fit even more discretely behind a WC

NEW for back-to-wall or wall hung WC installations

Double access to the product

- Direct access to the tank in case of blockages
- Direct access to the electrical connections to change any used parts.

Quieter products

- The quietest macerator range on the market – 48 dB(A) for Sanipack Pro Up and Saniwall Pro Up.



SANIPACK® Pro UP
See page 08

SANIWALL® Pro UP
See page 11

Conventional plumbing uses gravity to allow drainage to conveniently sited pipework and sewers. **But what if gravity isn't on your side?** What if drainage pipework is **inconveniently positioned**, perhaps when working in a loft or a basement?

Saniflo works **where convention doesn't**. The domestic range consists of 18 solutions for bathrooms and kitchens.

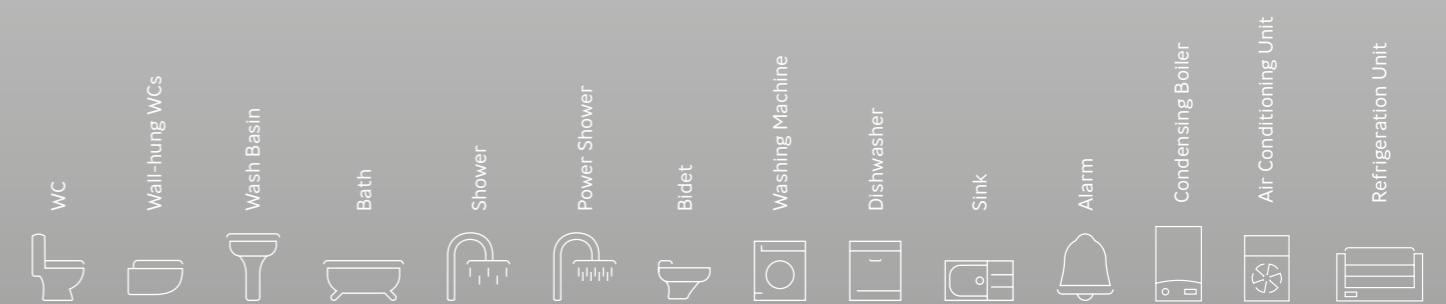
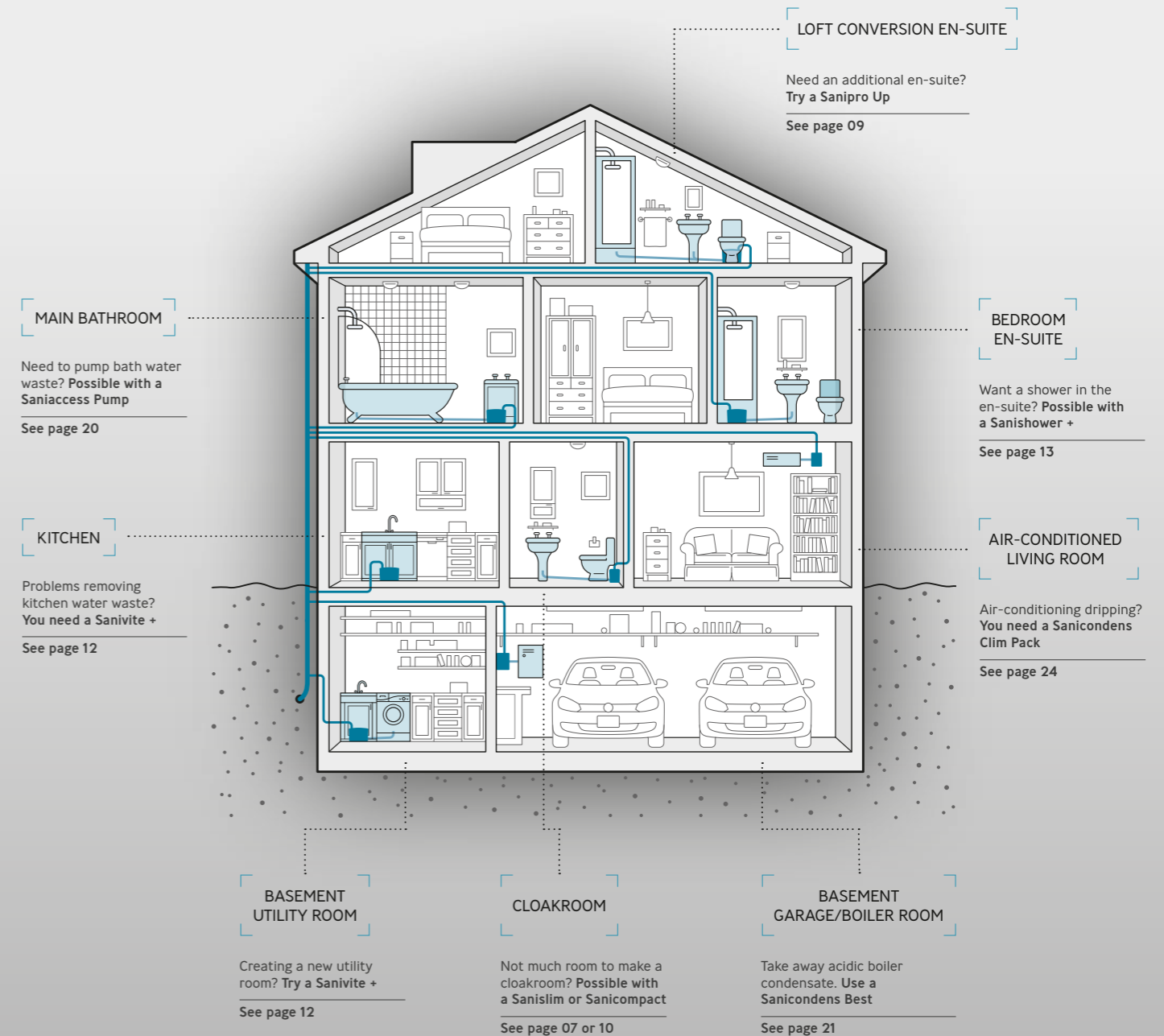

Products suitable for a whole variety of applications. (Just refer to each of the product keys on the relevant pages).

The original macerator pump unit that allows installation of an extra WC almost anywhere when a conventional solution isn't possible.



NEW

Why choose this product?

- Ideal for one WC
- Unobtrusive with a quiet motor
- Easy access for servicing and maintenance
- No need to change the pipework - replaces existing Saniflo products
- Improved design of casing

Vertical/horizontal performance

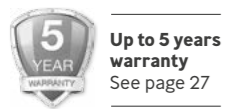
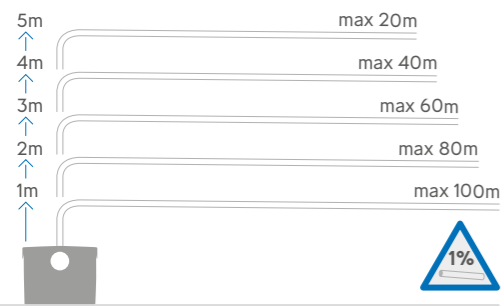

Up to 5 years warranty
See page 27

200mm depth required behind the WC

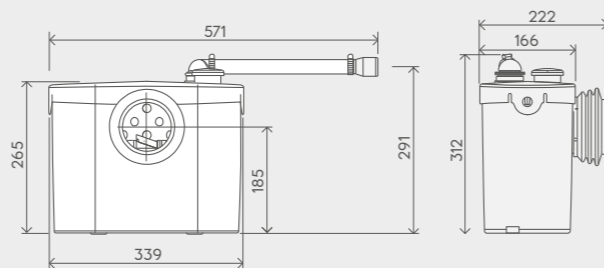
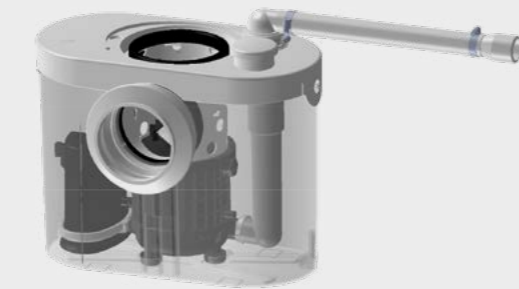

Discharge Pipework
22 / 28 / 32mm

Product Weight
5.4kg

Motor Power
400 Watts

Inlet Pipework
40mm

Voltages
220-240 V/50 Hz

IP Rating
IP44

Working Waste Water Temp
35°C

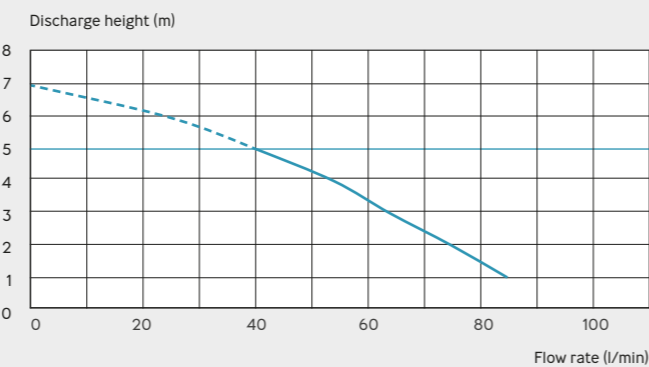

Similar to the original Saniflo Up but allows connection of a WC and a wash basin to one macerator pump. A great choice for a small cloakroom.



NEW

Why choose this product?

- Unobtrusive with a quiet motor
- One top waste inlet
- Easy access for servicing and maintenance
- No need to change the pipework - replaces existing Saniflo products
- Improved design of casing

Vertical/horizontal performance

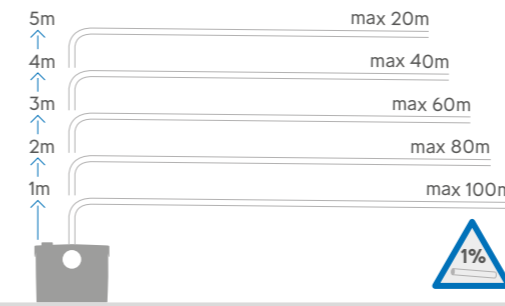

Up to 5 years warranty
See page 27

200mm depth required behind the WC

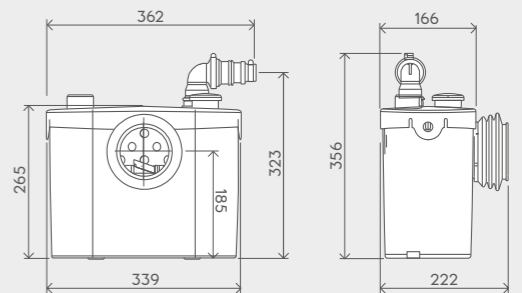

Discharge Pipework
22 / 28 / 32mm

Product Weight
5.4kg

Motor Power
400 Watts

Inlet Pipework
40mm

Voltages
220-240 V/50 Hz

IP Rating
IP44

Working Waste Water Temp
35°C

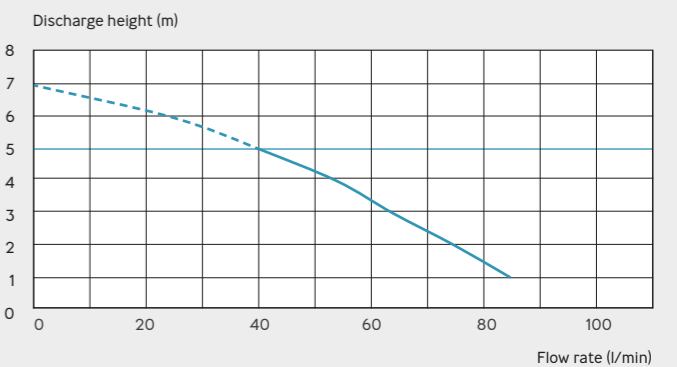



Product Ref: 6003

The Saniplus Up enables you to install an additional bathroom with ease. With two inlets and a greater tank capacity, the Saniplus Up can easily deal with a WC, wash basin, bidet and even the highest output power showers.

Why choose this product?

- One unit deals with the waste from an additional bathroom
- Works with high output power showers
- Two side inlets and a greater tank capacity
- Easy access for servicing and maintenance
- No need to change the pipework - replaces existing Saniflo products
- Improved design of casing

Vertical/horizontal performance

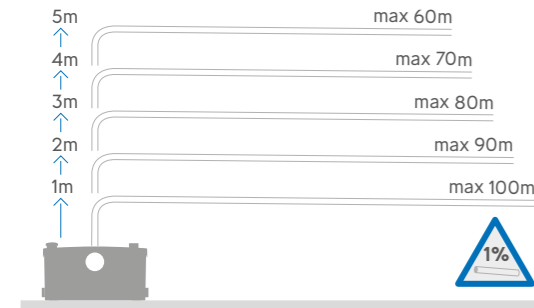

210mm depth required behind the WC



NEW



Product Ref: 1054/1

When you need slimline sanitaryware you need a macerator pump to match. Sanislim needs just 145mm depth behind the WC and, with an inlet either side, can take waste from a WC, a shower, wash basin and bidet if required.

Why choose this product?

- Designed to fit behind the latest slimline styles of WC
- Deals with all waste from a small bathroom
- Inlets either side of unit

Vertical/horizontal performance

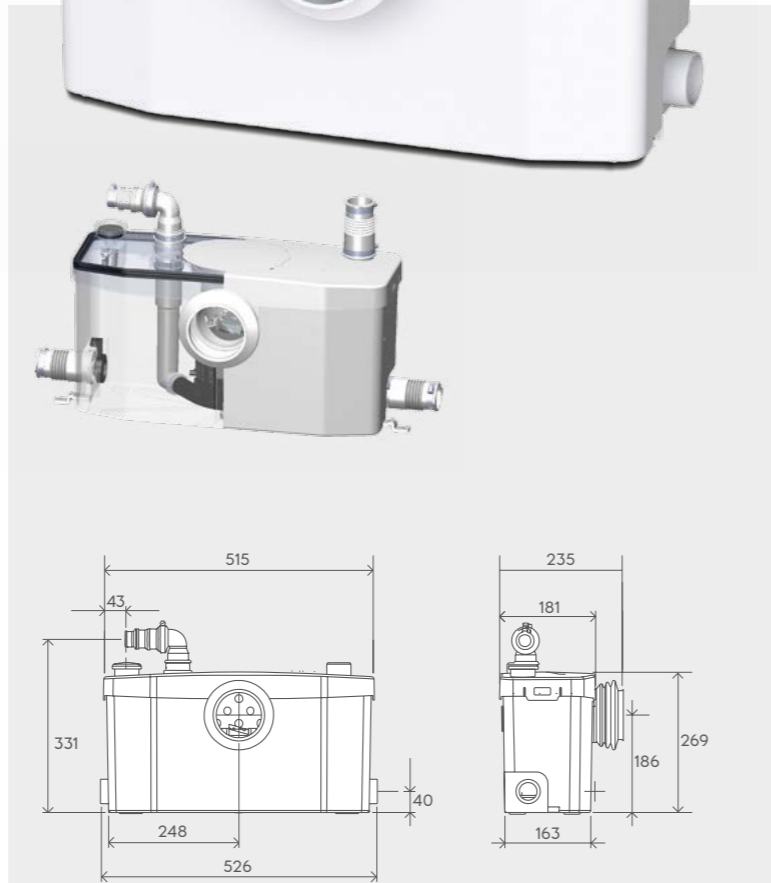

Discharge Pipework 22 / 28 / 32mm	Product Weight 6.4kg
Motor Power 400 Watts	Inlet Pipework 40mm
Voltages 220-240 V/50 Hz	IP Rating IP44
Working Waste Water Temp 35°C	

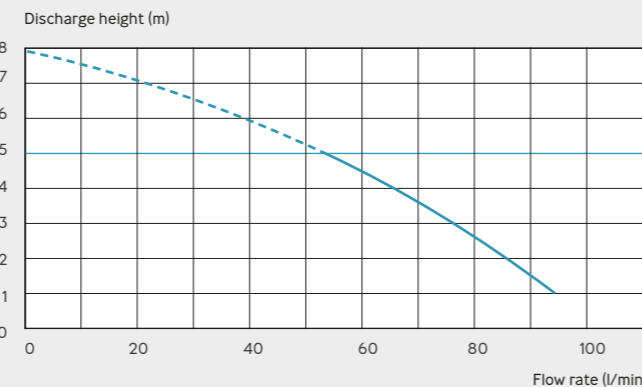

Only 145mm depth required behind the WC. Clearance of 320mm is required from floor level to the underside of a close coupled suite to accommodate the discharge elbow.

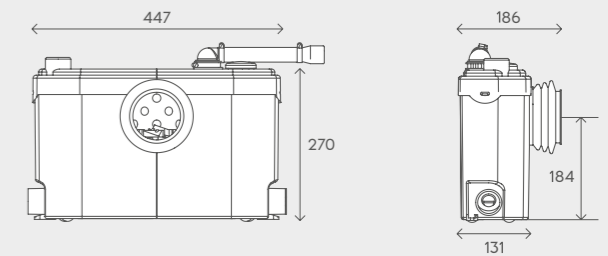

Discharge Pipework 22 mm	Product Weight 5.8kg
Motor Power 400 Watts	Inlet Pipework 40mm
Voltages 220-240 V/50 Hz	IP Rating IP44
Working waste Water Temp 35°C	

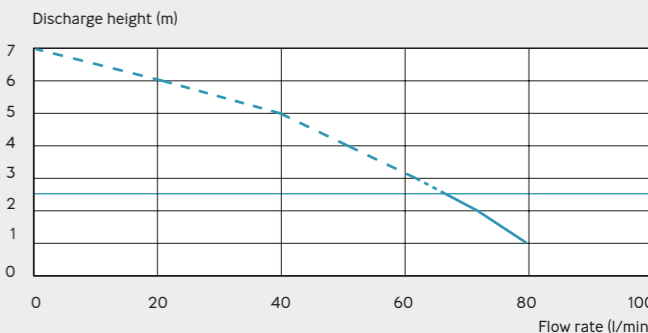

SANIPACK® Pro UP

Product Ref: 6052

Designed to be concealed from view, where back-to-wall or wall-hung sanitaryware is required, the extra slim Sanipack Pro Up can take waste from a WC, wash basin and shower. An ideal choice for a modern, sleek finish.

Why choose this product?

- Perfect solution for a complete shower room installation
- Ideally suited for fitted bathroom units
- Capacity to connect WC, wash basin, bidet and shower
- Easier access to both the tank and electrical connections.
- Quiet motor
- Extra slim dimensions

Vertical/horizontal performance

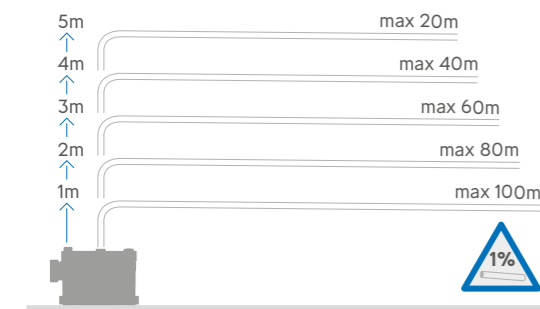

5 YEAR WARRANTY
Up to 5 years warranty
See page 27



NEW

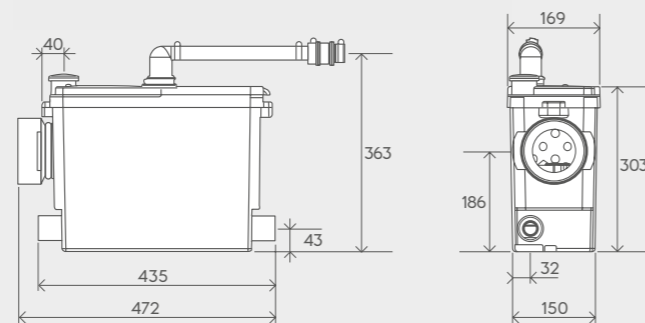

Discharge Pipework
22 / 28 / 32mm

Motor Power
400 Watts

Voltages
220-240 V/50 Hz

Working Waste Water Temp
35°C

Product Weight
7kg

Inlet Pipework
40mm

IP Rating
IP44

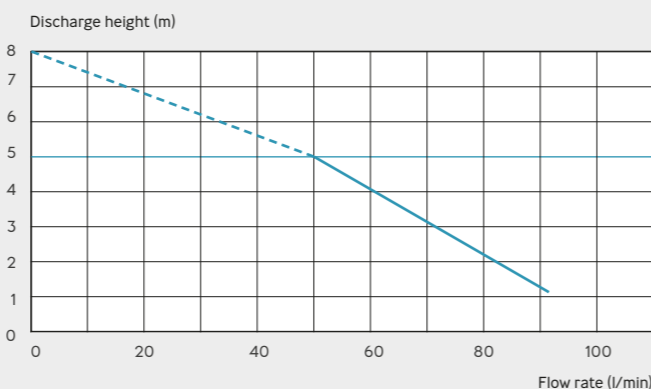

SANIPRO® UP

Product Ref: 6006

The Sanipro Up is ideal for adding an en-suite. With two inlets the Sanipro Up can easily deal with a WC, wash basin, bidet and a power shower.

Why choose this product?

- Compact, neat and unobtrusive
- Capacity for an en-suite installation
- Inlets either side of unit
- Easy access for servicing and maintenance
- No need to change the pipework - replaces existing Saniflo products
- Improved design of casing

Vertical/horizontal performance



5 YEAR WARRANTY
Up to 5 years warranty
See page 27

210mm depth required behind the WC



NEW

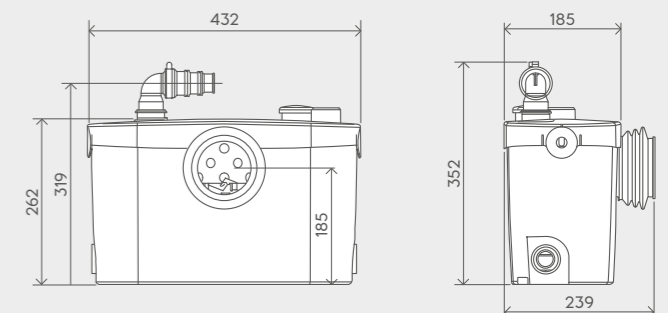

Discharge Pipework
22 / 28 / 32mm

Motor Power
400 Watts

Voltages
220-240 V/50 Hz

Working Waste Water Temp
35°C

Product Weight
6.4kg

Inlet Pipework
40mm

IP Rating
IP44

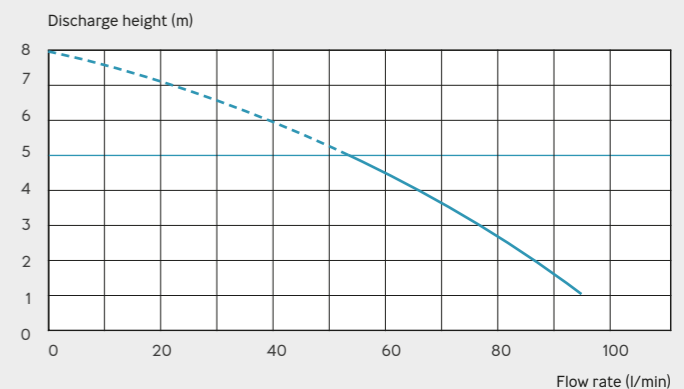

A super-compact WC unit with a built in macerator that's perfect for small cloakrooms. It even features a wash-basin inlet and needs no cistern to make the most of the smallest spaces.



Why choose this product?

- A WC with built in macerator
- Automatic push-button flush connected directly to the domestic water supply
- Needs no cistern
- Features a soft-close toilet seat
- Water saving flush system

Vertical/horizontal performance



Requires a minimum of 1.7 bar water supply pressure



With a built-in frame system designed to accommodate all types of wall-hung WC (not supplied), Saniwall Pro Up has a dual flush and an integral macerator pump. In addition to taking the waste from a WC there are two side inlets enabling a wash basin, shower and bidet to drain to the macerator.



NEW

Why choose this product?

- Designed with Grohe cistern Technology
- Concealed unit ideal for use with built-in bathroom furniture
- Ideal for wall-hung WCs
- Built in frame system with an elegant glass wall covering
- Integrated dual flush cistern
- Adjustable feet allow variable heights of pan
- Two side inlets
- Flush plate included
- Easier access to both the tank and electrical connections.
- Quiet motor

Vertical/horizontal performance



Saniwall Pro Up has been awarded AFISB (French Association of Bathroom Industries) WELLBEING certification, to recognise its contribution to helping people with reduced mobility.

Mounting centres for WC pan are 180-230mm

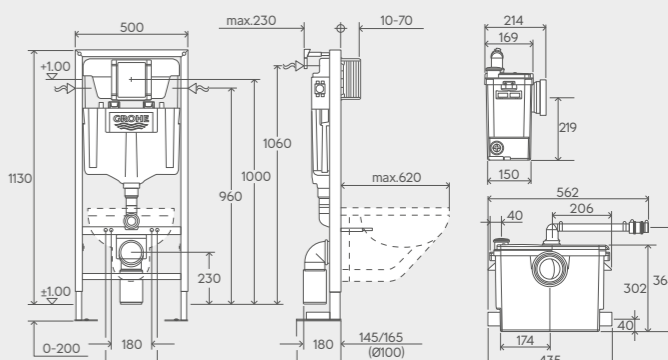
Discharge Pipework: 22 / 28 / 32 mm

Product Weight: 15kg

Motor Power: 400 Watts

Inlet Pipework: 40mm

Voltages: 220-240 V/50 Hz

IP Rating: IP44

Working Waste Water Temp: 35°C

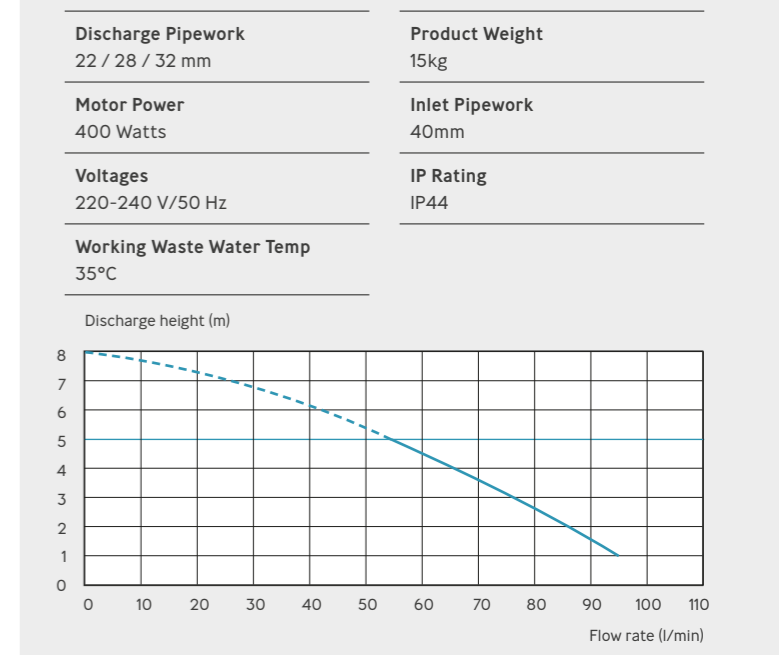

Product Ref: 6004

Ideally suited to a kitchen or utility room, Sanivite +’s powerful pump has four inlets for connection to domestic sinks or appliances. With compact dimensions, Sanivite + can be concealed in a kitchen unit or behind a demountable panel to give access for servicing.

Why choose this product?

- Ideal for hot, soapy water
- Four inlets
- Powerful, quiet pump
- Low activation level (95mm)
- Compact for concealed installation

Vertical/horizontal performance

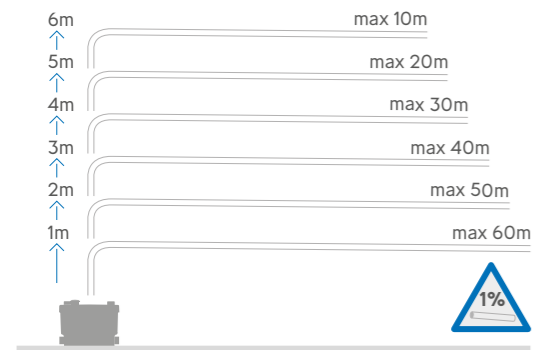

5 YEAR WARRANTY
Up to 5 years warranty
See page 27



NEW

Product Ref: 6043

The Sanishower + can be installed next to a shower tray with access for maintenance. Capable of pumping a standard electric or gravity mixer shower. Two inlets mean a wash basin can be added too.

Why choose this product?

- Overcomes gravity drainage issues
- Allows basement showers
- Can be fitted next to shower tray!
- Additional inlet for basin
- Includes integrated carbon filter
- Low activation level (65mm)

Vertical/horizontal performance

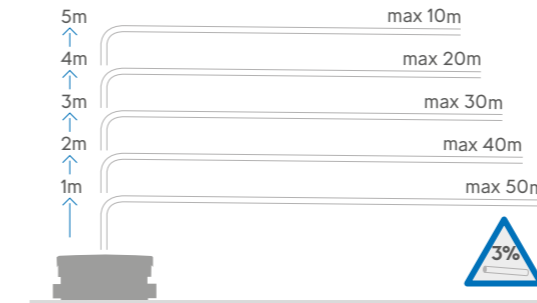

5 YEAR WARRANTY
Up to 5 years warranty
See page 27

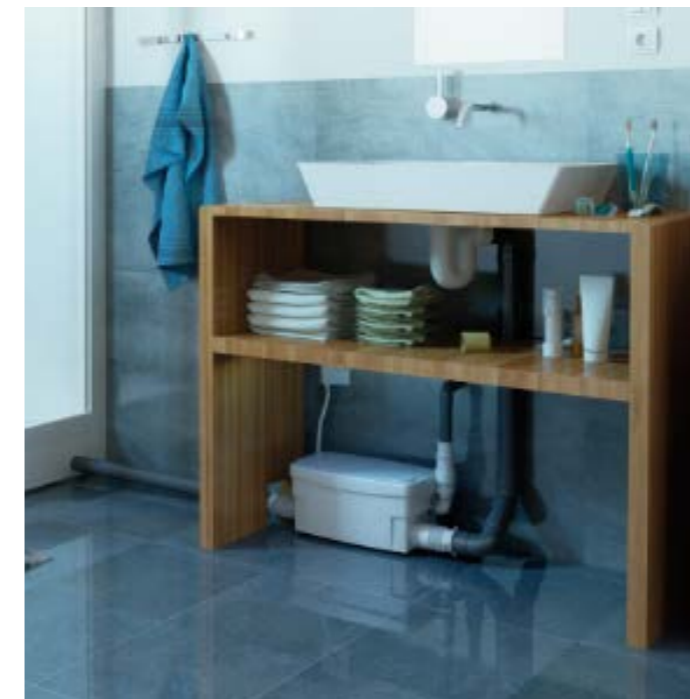

NEW

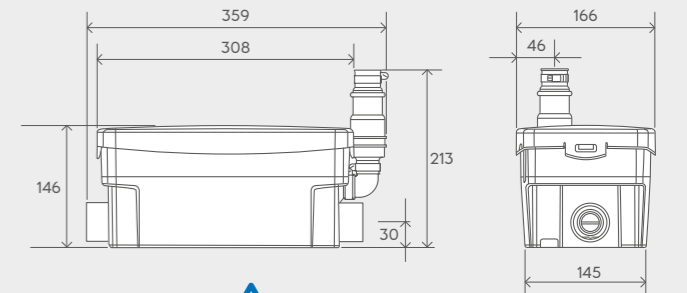
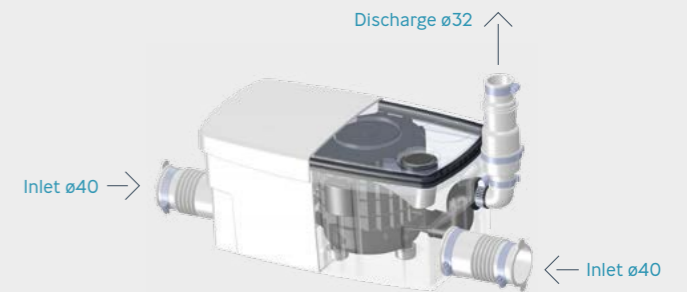

Discharge Pipework 22 / 32mm	Product Weight 3.5kg
Motor Power 400 Watts	Inlet Pipework 40mm
Voltages 220-240 V/50 Hz	IP Rating IP44
Working Waste Water Temp 35°C	Activation Level 65mm

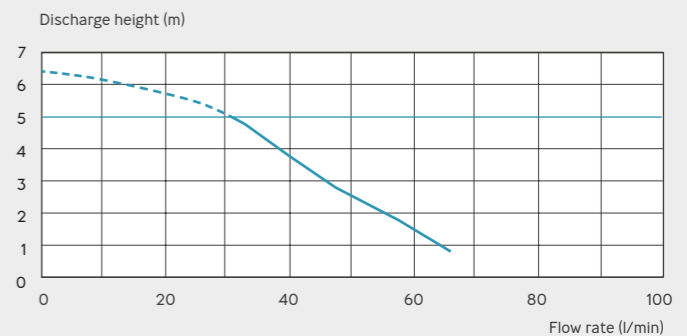

SANISHOWER® FLAT

Product Ref: 1043/3

Ideal pumping solution for a low level shower tray. Capable of pumping a standard electric or gravity mixer shower. Two inlets mean a wash basin can be added too.

Why choose this product?

- Suits low-level shower trays of 80mm and over
- Overcomes gravity drainage issues
- Allows basement showers
- Additional inlet for basin
- Two part kit with Sanishower + pump plus gully and waste
- Low level activation

Vertical/horizontal performance

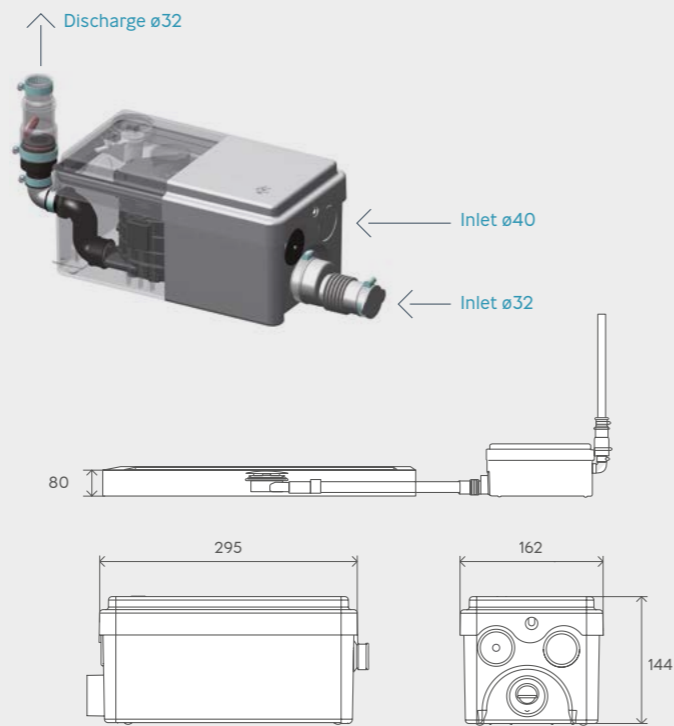

Discharge Pipework
22 / 32mm

Motor Power
250 Watts

Voltages
220-240 V/50 Hz

Working Waste Water Temp
35°C

Product Weight
3.7kg

IP Rating
IP44

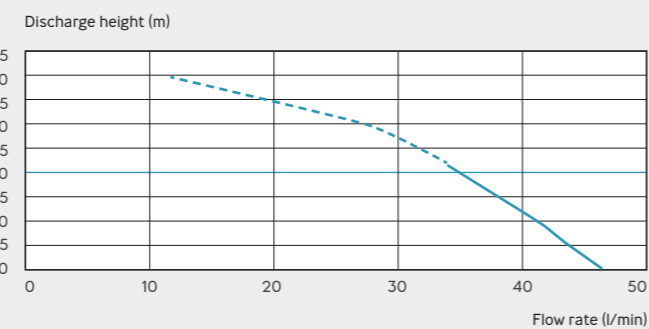

SANIFLOOR®

Product Ref: 1154/1155/1156

Designed specifically where floor drainage is required but where space underneath is very limited e.g. wet rooms. This two part kit with a powerful shower waste pump and a choice of three waste designs can pump up to 3m vertically as well as 30m horizontally. Higher flow rate means it can be used with powerful 'rain head' showers.



Why choose this product?

- Suits wet rooms and low level shower trays
- Ideal for high flow applications
- Pump and waste inlet can be up to 3m apart horizontally
- Dual function - sucks waste up from the gully and pumps waste water away up to 3m vertically or 30m horizontally
- Pump can be sited up to 300mm above the gully
- All gully types are 90mm in diameter

Vertical/horizontal performance



Gully Types

- 1 Ref 1154: With shower waste for tiled floor - Height 68mm
- 2 Ref 1155: With shower waste for vinyl floor - Height 68mm
- 3 Ref 1156: With shower waste for trays - Height 63mm

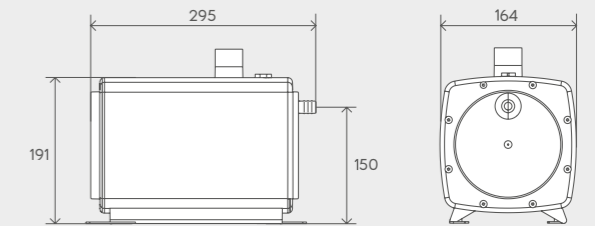

Discharge Pipework
32 mm

Motor Power
400 Watts

Voltages
220-240 V/50 Hz

Working Waste Water Temp
35°C

Product Weight
Sanifloor 1 - 7.9kg

Sanifloor 2 - 7.9kg

Sanifloor 3 - 7.7kg

IP Rating
IP44

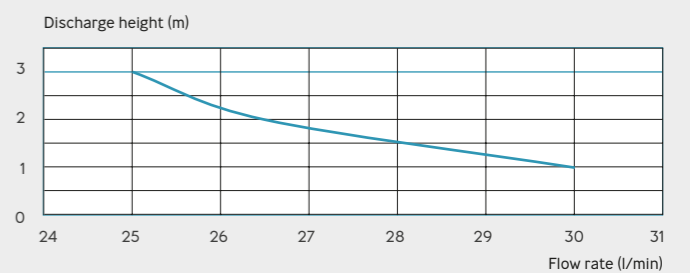

TRAYMATIC® EXTERIOR

Product Ref: RD590AD/RD591AD/RD592AD/RD593AD/ RD594AD/RD595AD

This low profile shower tray is equipped with an external wastewater pump, making it an ideal solution for installing a shower almost anywhere with minimal disruption, as no excavation is required. Tray height is only 53mm for easy access.



TRAYMATIC® Exterior

RD590AD - 800 x 800 x 53mm RD593AD - 1000 x 800 x 53mm LH
 RD591AD - 900 x 900 x 53mm RD594AD - 1200 x 800 x 53mm RH
 RD592AD - 1000 x 800 x 53mm RH RD595AD - 1200 x 800 x 53mm LH

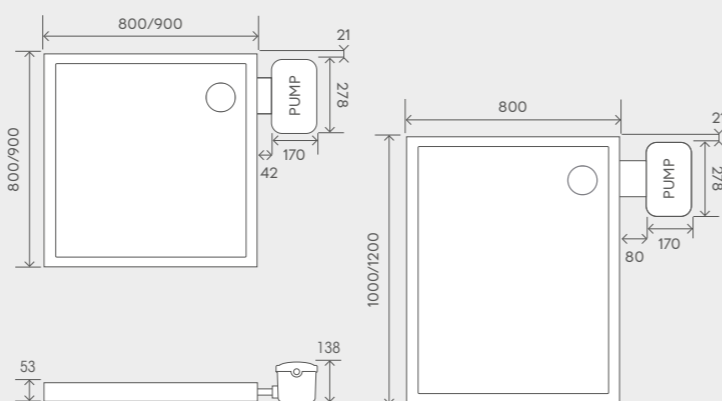

Discharge Pipework
22/32 mm

Motor Power
250 Watts

Voltages
220-240 V/50 Hz

Working Waste Water Temp
35°C

Product Weight
3.5kg (pump only)

IP Rating
IP44

Discharge height (m)

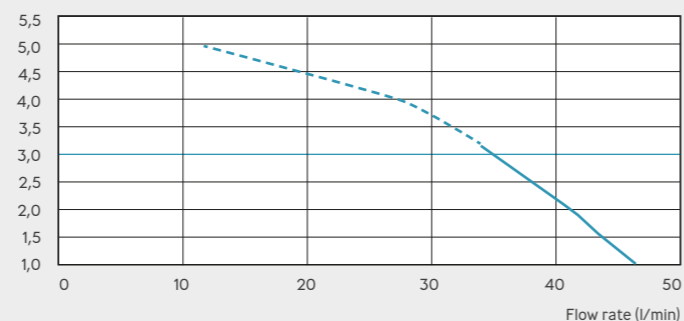

Why choose this product?

- Low level shower tray for ease of access for the less abled
- External waste water pump
- Minimal disruption
- Maximises options for shower location
- No excavation required
- Anti-slip surface

Vertical/horizontal performance

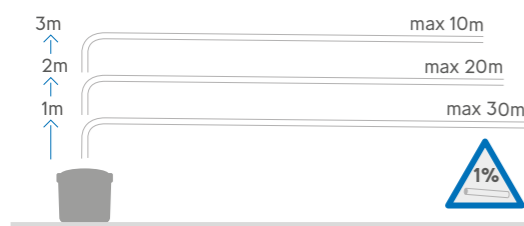

SANIMATIC®

Product Ref: 1116

The Sanimatic is designed to make life easier for anyone with limited mobility. This ingenious toilet system gives the user adjustable height control to accommodate any accessibility requirements and includes remote flushing to remove the need to twist around.



Why choose this product?

- Easy to install - in as little as 2 hours for one person
- Compatible with most wall-hung bowls (not included)
- 37cm range of travel even when seated
- Allows easier sitting and standing
- Supports weights of up to 150kg
- Simple to use remote control panel, removes need to twist for flushing
- Stylish, neutral design integrates with bathroom décor
- Unit panel can be personalised: painted, framed or semi-recessed
- Suits horizontal and vertical discharge connection
- Optional armrests available
- Can be combined with a Sanipack Pro Up macerator

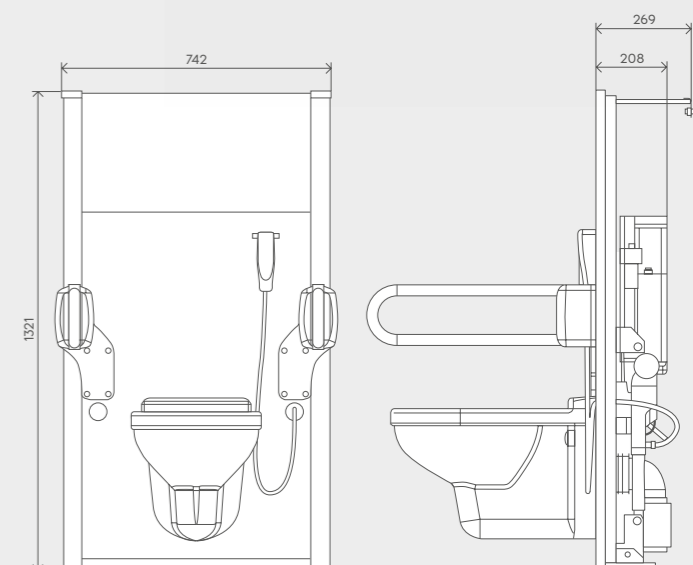

Amplitude of Movement
370mm. Low of 380mm to a high of 750mm

Operation
By hard wired remote control handset

Cistern
6L with push button flush or via the handset

Mobile Panel
In white ABS, can be painted

Motorised Frame
Treated steel with lifting capability of 150kg

Pan
Fixing axis 180-230mm



SANI ACCESS® 1 2 3

Products Ref: 1900/1901/1902

Designed to provide easy access for en-suite bathroom applications, convenient covers allow you to service and maintain the macerator without having to remove it.

Suitable for new installations.



SANI ACCESS® 1



SANI ACCESS® 2



SANI ACCESS® 3



Why choose this product?

- Easy service access
- Suitable for one WC only
- Easy maintenance without removal of unit
- Suitable for new installations
- Quiet technology

Saniaccess is primarily intended for new installations as the inlet and outlet positions vary from other Saniflo models.

Vertical/horizontal performance

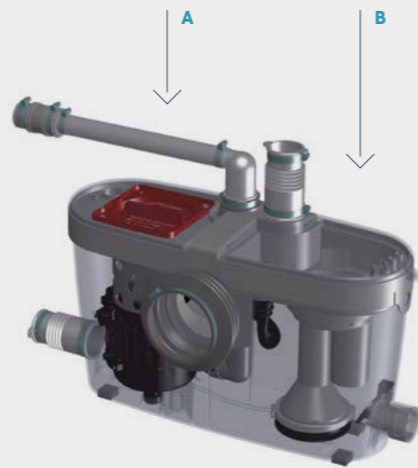
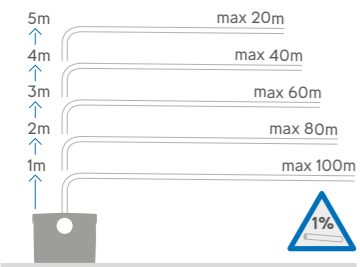

Double access:

- A** Direct access to the basket in case of blockage due to misuse
- B** Direct access to electric components

Discharge Pipework
22 / 28 / 32 mm

Motor Power
400 Watts

Voltages
220-240 V/50 Hz

Working Waste Water Temp
35°C

Product Weight
Saniaccess 1 and 2 - 5.8kg
Saniaccess 3 - 6.4kg

Inlet Pipework
40mm

IP Rating
IP44

Discharge height (m)

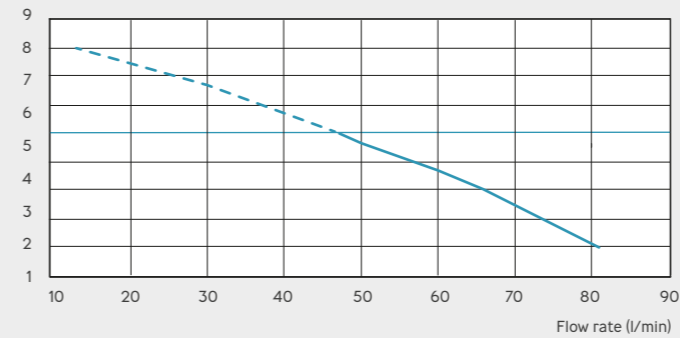

SANI ACCESS® 1

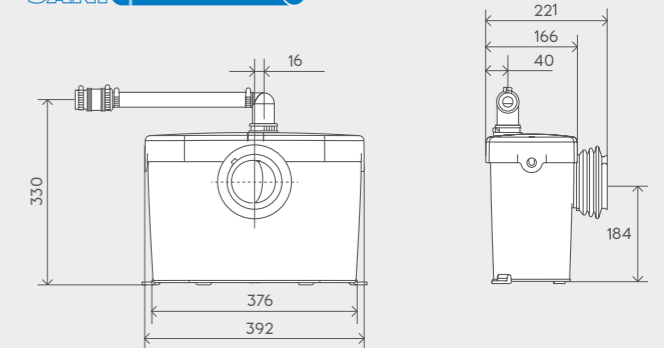

SANI ACCESS® 2

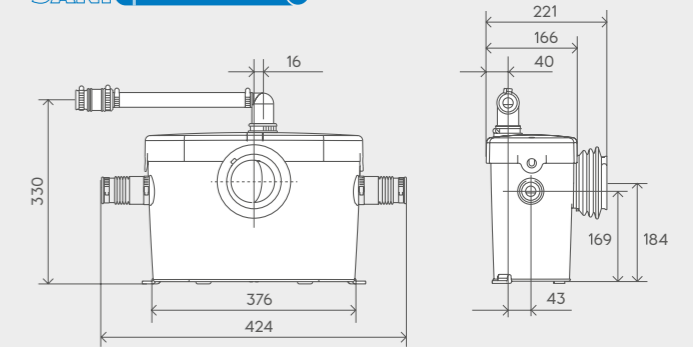

SANI ACCESS® 3

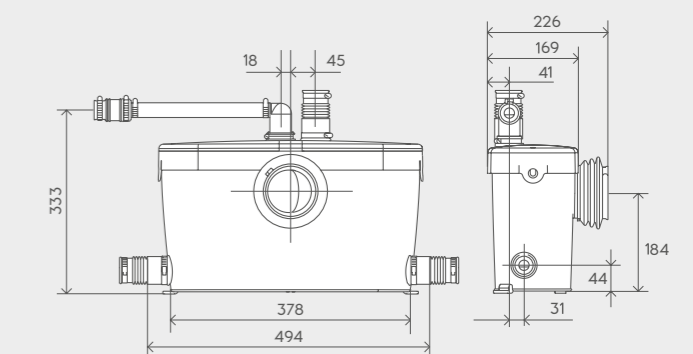



Product Ref: 1903

Designed to provide easy access for grey water pumping applications such as kitchens and utility rooms. Convenient covers allow simple service and maintenance of the pump without having to remove it.

Suitable for new installations.



Why choose this product?

- Easy service access
- Suitable for grey water
- Easy maintenance without removal of unit
- Suitable for new installations
- Quiet technology
- Two side inlets and optional top inlet

Saniaccess Pump is primarily intended for new installations as the inlet and outlet positions vary from other Saniflo models.

Vertical/horizontal performance

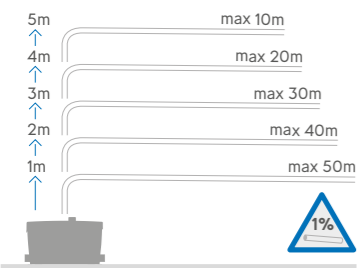

Product Ref: 1082/2

The Sanicondens® Best is specifically designed for disposal of acidic concentrate from boilers and other water producing equipment such as air conditioning units, refrigeration units and dehumidifiers etc. Incorporates a pH neutralising granule tray and includes a non-return valve and 6m flexible discharge pipe.



Why choose this product?

- Designed to dispose of acidic condensate
- 2 litre tank
- Integrated pH neutralising granule tray
- Four entry points
- Working temperature of 35°C. Will handle temperatures up to 80°C for short periods and a minimum pH of 2.5

Vertical/horizontal performance

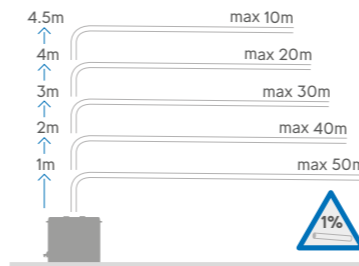

Sanicondens Best

The tank of the Sanicondens Best has a float which controls the pump. When the condensate gathers in the tank the pump is activated. The product has its own neutralization tray to adjust the pH of the acidic water from the condensing boiler. Sanicondens Best is also fitted with a second float that can control an alarm.

Accessories supplied with the product:

Non-return valve, wall fixing kit, 2 inlet adaptors, connection for an alarm, 2 metres of electric cable, 6 metres of drainage pipe.

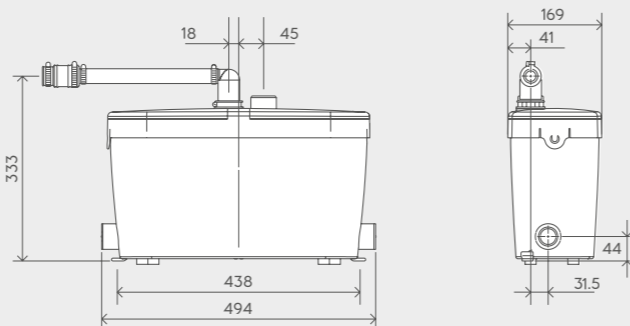
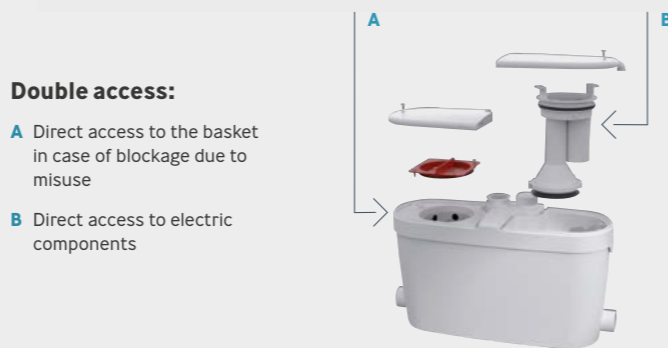

Discharge Pipework 32 mm
Motor Power 400 Watts
Voltages 220-240 V/50 Hz
Working Waste Water Temp 75°C

Product Weight 6.4kg
Inlet Pipework 40mm
IP Rating IP44

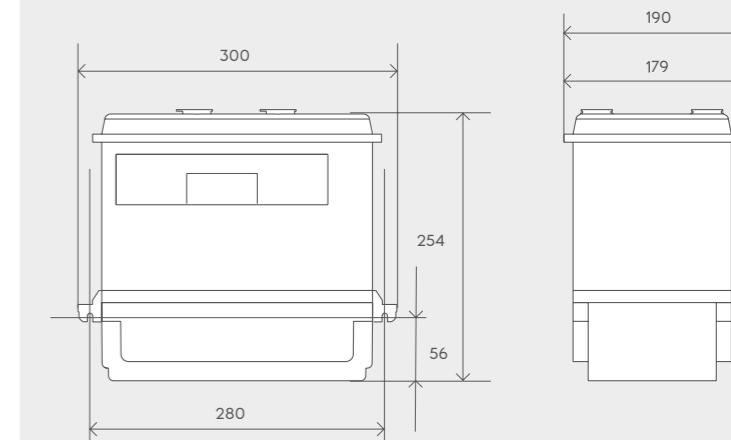
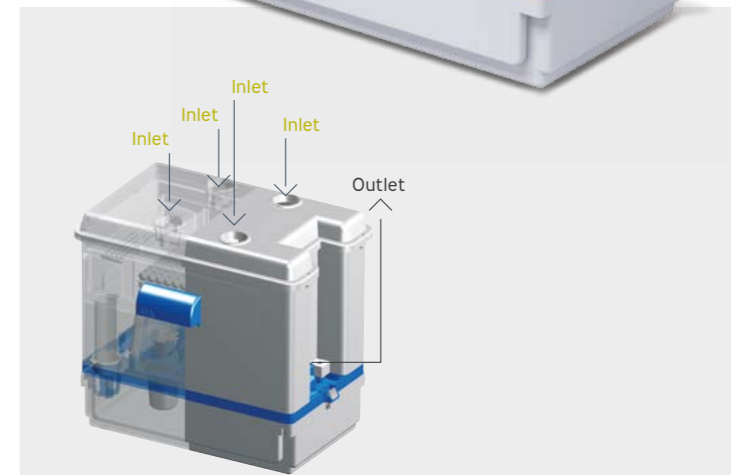
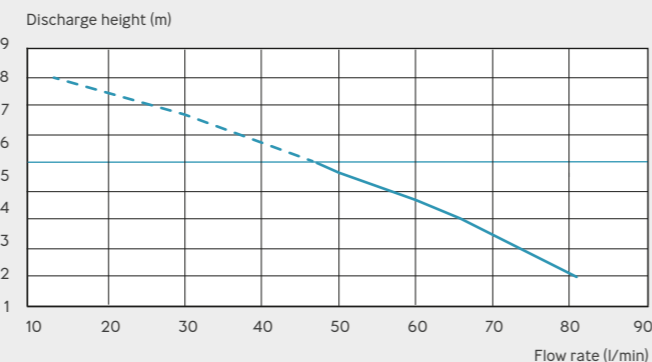

Discharge Pipework 8mm
Motor Power 60 Watts
Flow Rate 342L/h
Voltages 220-240 V/50 Hz
Tank Volume 2L

Working Waste Water Temp 35°C/Max 80°C (intermittent)
Product Weight 2.6kg
Inlet Pipework 28mm
IP Rating IP20

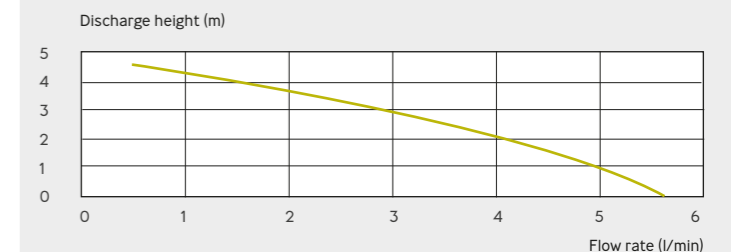

SANICONDENS® Pro

Product Ref: 1082/5

The Sanicondens® Pro is specifically designed for disposal of acidic concentrate from boilers and other water producing equipment such as air conditioning units refrigeration units and dehumidifiers etc. Includes a non-return valve and 6m flexible discharge pipe. Similar to Sanicondens® Best, but for use where a neutralising tray is not required.



Why choose this product?

- Designed to dispose of acidic condensate
- 2 litre tank
- Two entry points
- Working temperature of 35°C.
Will handle temperatures up to 80°C for short periods and a minimum pH of 2.5
- For use where a neutralising tray is not required
- Supplied with 2m of electric cable and 6m of drainage pipe

Vertical/horizontal performance

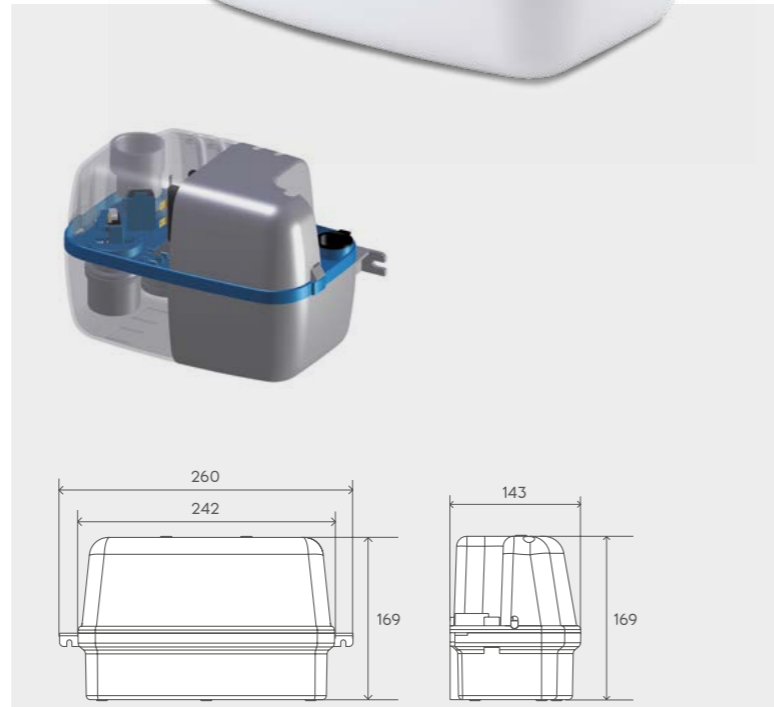
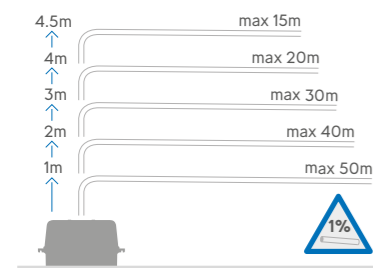

Discharge Pipework 8/11mm	Working Waste Water Temp 35°C/Max 80°C (intermittent)
Motor Power 60 Watts	Product Weight 2kg
Flow Rate 342L/h	Inlet Pipework 28mm
Voltages 220-240 V/50 Hz	IP Rating IP20
Tank Volume 2L	

SANICONDENS® Eco

Product Ref: 1133

The Sanicondens® Eco is specifically designed for disposal of acidic concentrate from boilers and other water producing equipment such as air conditioning units refrigeration units and dehumidifiers etc. Similar to Sanicondens Best®, but has a smaller tank capacity.

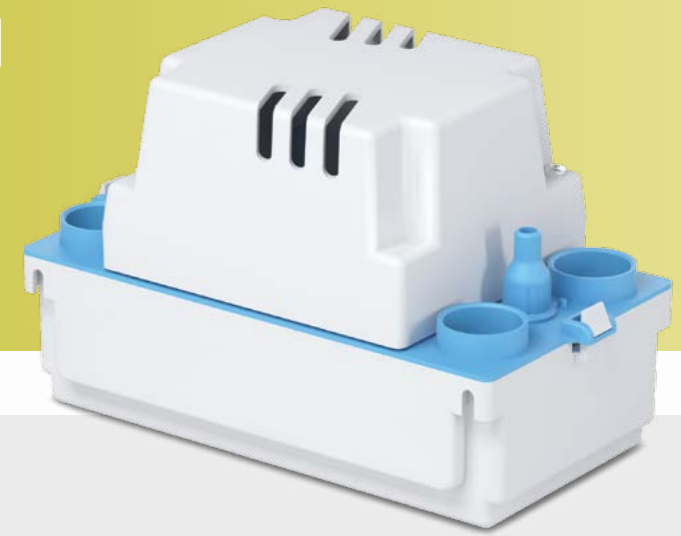

Why choose this product?

- Designed to dispose of acidic condensate
- 1 litre tank
- Four entry points
- Working temperature of 35°C.
Will handle temperatures up to 80°C for short periods and a minimum pH of 2.5
- For use where a neutralising tray is not required
- Supplied with 2m of electric cable and 6m of drainage pipe

Vertical/horizontal performance

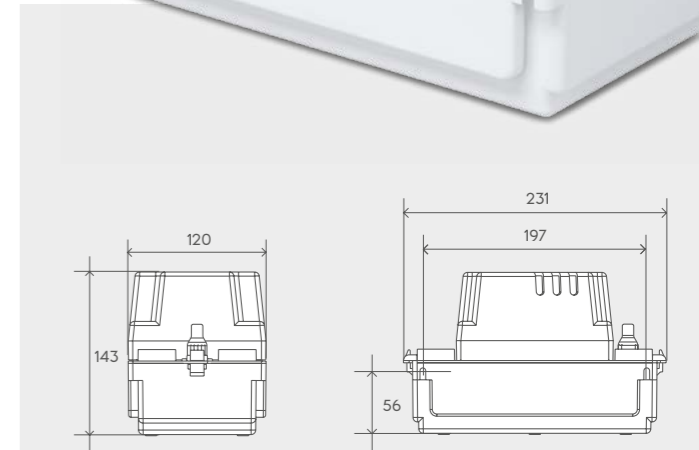
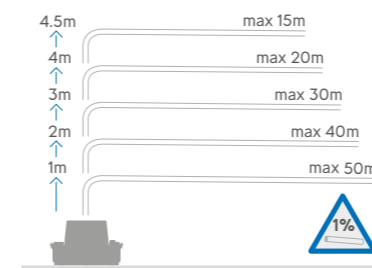

Discharge Pipework 8/11mm	Tank Volume 1L
Motor Power 60 Watts	Working Waste Water Temp 35°C/Max 80°C (intermittent)
Flow Rate 342L/h	Product Weight 1.3kg
Voltages 220-240 V/50 Hz	Inlet Pipework 28mm
	IP Rating IP20

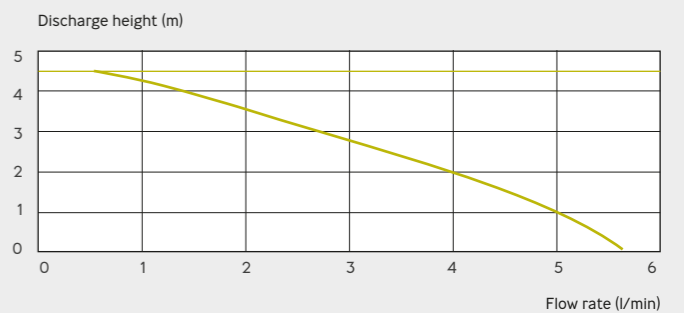

SANINEUTRAL

Product Ref: 1082/4



The Sanineutral will neutralise the acidic condensate from a boiler before the waste is drained away, hence protecting pipework and the environment from damage. It works without a pump but can be placed in the pipework before a Sanicondens® Pro or Eco.



Why choose this product?

- Designed to neutralise the acidic concentrate from a boiler
- Suitable for condensing boilers up to 50kW
- Replaceable neutralising granule packs
- Easy maintenance and fits on the wall or floor
- Top or side entry options

Discharge Pipework 40mm
Working Waste Water Temp 60°C
Tank Volume 1.2kg
Product Weight 1.7kg
Inlet Pipework Top 32mm / Side 40mm

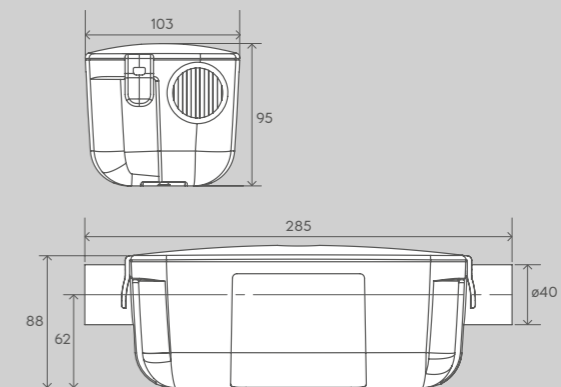

Replacement neutralising granule packs available

SANICONDENS® Clim Pack

Product Ref: 1132

The Sanicondens® Clim Pack has been specifically designed to expel the condensate from air conditioning units. The pack contains the Clim Mini pump plus trimmable trunking for a neat finish.



Why choose this product?

- Designed for air conditioning units
- Supplied with trunking that can be trimmed to size
- Very quiet operation

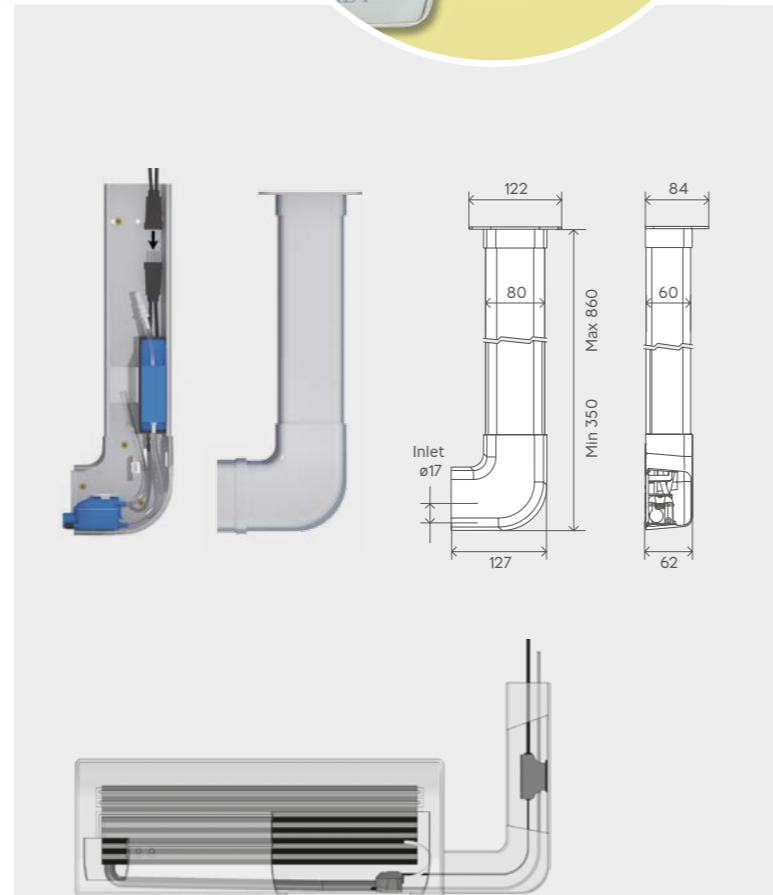

Discharge Pipework 8.5/10.5mm	Flow Rate 15L/h
Motor Power 22 Watts	Product Weight 4kg
Voltages 220-240 V/50 Hz	IP Rating IP20

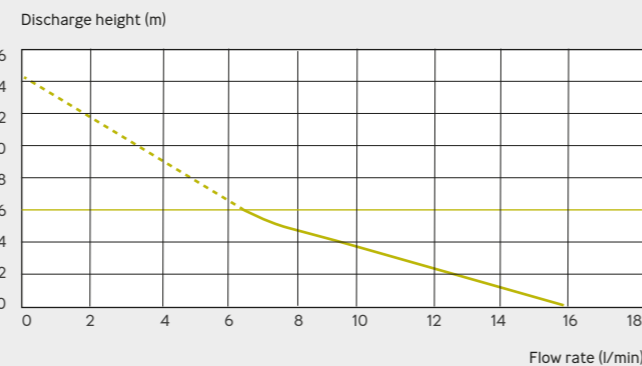

SANICONDENS® Clim Mini

Product Ref: 1131

The Sanicondens® Clim Mini has been specifically designed to expel the condensate from air conditioning units.



Why choose this product?

- Designed for air conditioning units
- Very quiet operation

Why not use the Sanicondens Clim Pack to get a neat decorate finish? See opposite.

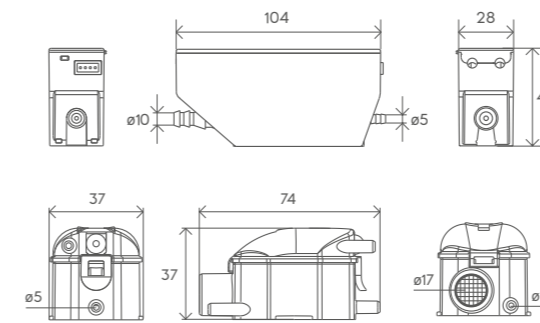

Discharge Pipework 8.5/10.5mm	Flow Rate 15L/h
Motor Power 22 Watts	Product Weight 3kg
Voltages 220-240 V/50 Hz	IP Rating IP20

Vertical suction in metres (A)	Vertical pumping in metres (B)	Horizontal pumping in metres (C)			
		5	10	20	30
0	1	10.4	9.1	8.3	7.3
	2	8.9	7.8	7.0	6.4
	3	7.9	7.1	6.3	5.8
	4	7.0	6.0	5.3	4.9
1	1	8.9	8.3	7.5	5.9
	2	7.8	7.3	6.7	6.1
	3	6.9	6.7	5.7	5.4
	4	5.9	5.5	4.9	4.4
1.5	1	7.8	7.6	6.9	6.5
	2	7.1	6.6	6.2	5.7
	3	6.5	5.7	5.1	4.8
	4	5.5	4.8	4.2	3.9

SANICONDENS® Clim Deco

Product Ref: 1134

An easy to install, discreet pump to expel the condensate from air conditioning units and refrigeration units.



Why choose this product?

- Designed for air conditioning and refrigeration units
- Prevents dripping
- Very quiet operation
- Easy installation

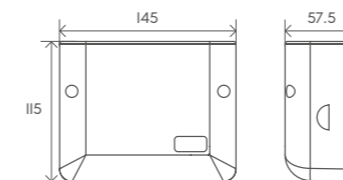

Installation diagram

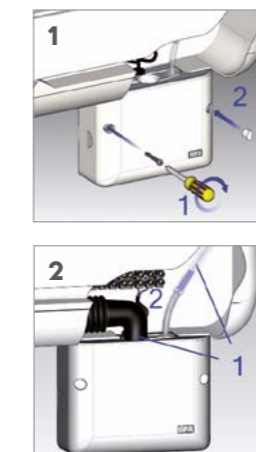

Discharge Pipework 8/10mm	Voltages 220-240 V/50 Hz	Product Weight 2kg
Motor Power 16 Watts	Flow Rate 12L/h	IP Rating IP24

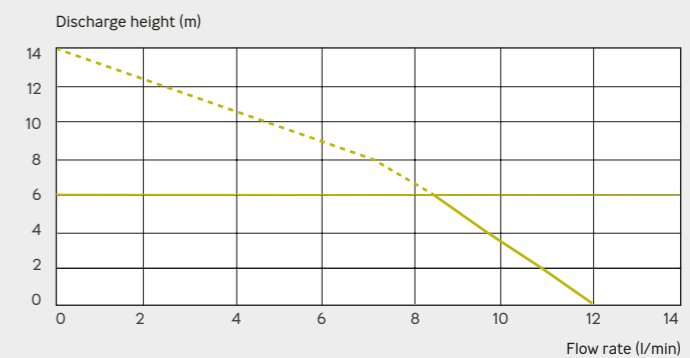

SANIALARM®

Product Ref: 1095

The Sanialarm® has a level pressure switch that triggers an alarm fixed on the top of a unit if the volume of water exceeds the maximum allowed level. The alarm emits a continuous warning sound, until it is switched off and the problem rectified.

Why choose this product?

- Helps protect against flooding
- 80dB buzzer
- Added peace of mind
- Easily and quick installation onto lid of Saniflo unit
- Suitable for new and existing Saniflo installations
- Fits most Saniflo products – see product selector for details



Benefit from our extended warranty



In order to register your 3 year warranty extension, simply go to our website: saniflo.co.uk or fill in the warranty registration card inside the box and send it to us by post.

Our 3 year warranty extension is applied to the new **2017 versions** of **Saniflo Up, Sanitop Up, Saniplus Up, Sanipro Up, Sanipack Pro Up, Saniwall Pro Up, Sanivite +, Sanishower + and Sanispeed +.**

All other Saniflo products have a 2 year warranty period as standard.

SANIFLO® CLEANSER/DESCALER

Product Ref: 1085

Specifically created for use with Saniflo® units, the cleanser is a concentrated solution for optimum cleaning power and trouble-free maintenance.

Why choose this product?

- Ideally suited to Saniflo units
- Won't damage septic tanks
- Comes in a 5 litre bottle for multiple applications
- Prolongs unit life and efficiency
- Use more frequently in hard water zones



Correct Saniflo installation?

Check out the 10 Golden Rules

1

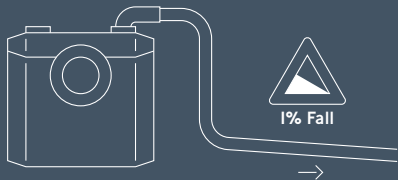

Discharge pipework should be copper or rigid solvent weld plastic, not 'pushfit'. 1% fall on horizontal runs.

2

If a vertical lift is needed, this should be as close to the start of the run as is practically possible and from the highest point there must be a minimum 1% fall. The closer the vertical lift is to the machine, the more efficient the pump will be.

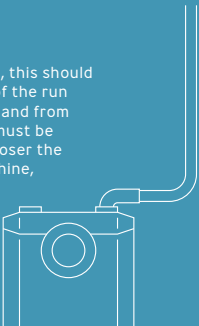

3

Bends should be smooth/long radius. This principle is true for all pipe sizes.

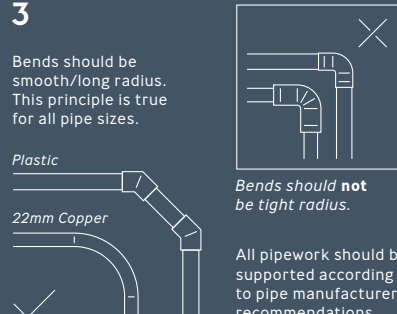

Plastic
22mm Copper

Bends should **not** be tight radius.

All pipework should be supported according to pipe manufacturers recommendations.

4

Pipes entering the Saniflo should have a gravity fall of 3%.

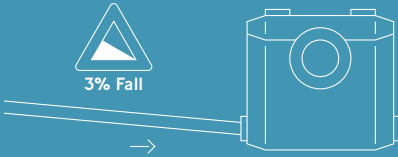

5

Where the pipework falls significantly below the unit e.g. a lower floor, fit an air admittance valve at the highest point capable of withstanding 10psi pressure, or increase pipe size coming down to 'break' syphon.

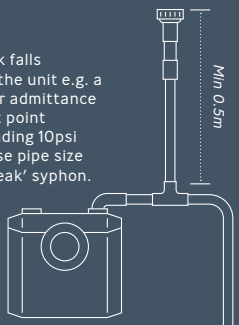

Min 0.5m

6

The unit should be easily accessible and removable in the event of maintenance being required. If boxed in, the boxing should be easily removed. Any extension between the WC pan spigot and wall should not exceed 200mm.

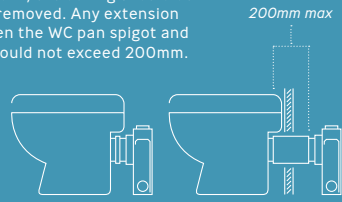

200mm max

7

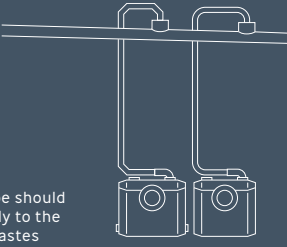

Each Saniflo discharge pipe should run separately to the soil pipe. If wastes are combined, it can only be into a larger pipe, which is on a gravity fall.

8

Since many closed coupled WC suites do not have the space between the WC pan spigot and the wall, you may have to batten the cistern off the wall to make room for the Saniflo. However Sanislim will fit behind most closed coupled WC suites without the need for this.



9

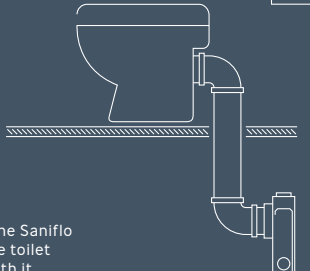

Position the Saniflo behind the toilet not beneath it.

10

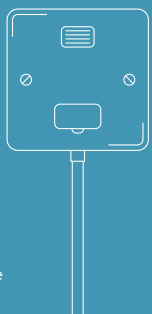

Electrical connection should be via an unswitched fixed wiring connector with a 5 amp fuse for Domestic range macerators. Professional range may vary - check individual instruction manual.

Saniflo offer a complete range of pumps and macerators for all applications.

Download our e-learning Module:
www.saniflo.co.uk/training/elearning



Macerators may only be used in a dwelling where there is access to a gravity discharging WC (Building Regs G4).

SANIFLO®

PLUMBING THE POSSIBILITIES

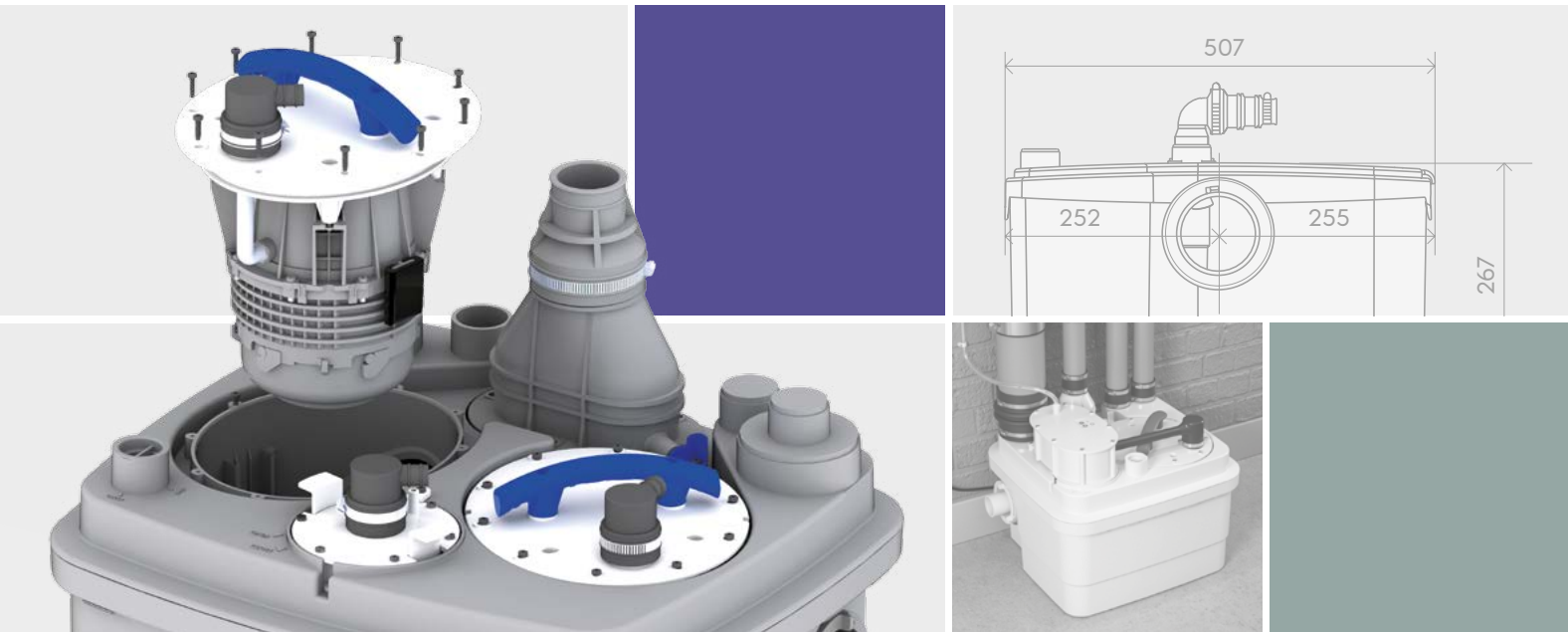

Saniflo – the facts

Saniflo macerator pumps and lifting stations reduce waste to liquid form and discharge through small-bore pipework to a soil stack or sewer.

This means real economies in labour and structural work by eliminating conventional four inch gravity discharge pipework. Saniflo units activate automatically when the cistern is flushed.

The units are quiet and economic to use and are simply connected to the domestic electrical supply, via an unswitched fused spur. The units are specifically designed for use in damp and steamy conditions and the powerful induction motors are sealed for life.

Thermal overload cut-outs are fitted to help protect them from abuse. Only the highest quality, non-corroding materials and components are used. Moving parts are minimised for maximum reliability and durability.

All our products are designed and manufactured in France and rigorously tested in our factory. We have years of experience in the market, constantly refining and improving our technology and we are confident on their reliability.

As part of the SFA Group, Saniflo are committed to an integrated quality and environmental management system and our business and factory complies with ISO 9001 and ISO 14001.

COMMERCIAL LIFTING STATIONS

2017



Not sure which Saniflo unit to specify?

Lift the flap for a full ready-reference guide as to which of our units is best suited to your specific installation.



SANIFLO®

PLUMBING THE POSSIBILITIES

Saniflo Limited

Howard House, The Runway, South Ruislip
Middlesex HA4 6SE, United Kingdom

Tel 020 8842 0033 Fax 020 8842 1671 Web www.saniflo.co.uk

As our policy is one of continuous product improvement we reserve the right to alter product specification without notice. All information in this publication is given in good faith. No responsibility can be accepted for any errors, omissions or incorrect assumptions. 01/17 29671UK

PRODUCT SELECTOR

All of our units can be used in any of these situations:
Basement, Ground Floor, Upper Floor, Loft/Attic –
just choose the right product for your installation...

	WC	Wall-hung WCs	Wash Basin	Bath	Shower	Power shower	Bidet	Washing Machine	Dishwasher	Sink ³	Alarm ¹
SANISPEED + Ref 6045			•	•	•	•	•	•	•	•	•
SANIBEST PRO Ref 1053	•	•	•		•	•	•				•
SANICOM 1 Ref 1046/1			•	•	•	•	•	•	•	•	
SANICOM 2 Ref 1046/2			•	•	•	•	•	•	•	•	
SANICUBIC 1 Ref 6101	•	•	•	•	•	•	•	•	•	•	2
SANICUBIC 2 PRO Ref 6102	•	•	•	•	•	•	•	•	•	•	2
SANICUBIC 2 CLASSIC Ref 6103	•	•	•	•	•	•	•	•	•	•	2
SANICUBIC 2 XL (SINGLE PHASE) Ref 6105	•	•	•	•	•	•	•	•	•	•	2
SANICUBIC 2 XL (THREE PHASE) Ref 6305	•	•	•	•	•	•	•	•	•	•	2
SANIFOS 110 (SINGLE PHASE) Ref 6106	•	•	•	•	•	•	•	•	•	•	2
SANIFOS 250 (SINGLE PHASE) Ref 6107	•	•	•	•	•	•	•	•	•	•	2
SANIFOS 500 (SINGLE PHASE) Ref 6108	•	•	•	•	•	•	•	•	•	•	2
SANIFOS 500 (THREE PHASE) Ref 6308	•	•	•	•	•	•	•	•	•	•	2
SANIPUMP Ref 6109	•	•	•	•	•	•	•	•	•	•	2

¹ Sanialarm can be fitted to these units if required.

² Sanialarm is fitted to these units as standard.

³ If connected to a kitchen sink, a grease trap must be fitted.

CONTENTS

Our product range has been divided into Domestic and Commercial categories to make it simple to find the product you're looking for, quickly and easily.



			COMMERCIAL
6045	SANISPEED +		4
1053	SANIBEST PRO		5
1046/1	SANICOM 1		6
1046/2	SANICOM 2		7
6101	SANICUBIC 1		8-9
6102	SANICUBIC 2 PRO		10-11
6103	SANICUBIC 2 CLASSIC		12-13
6105	SANICUBIC 2 XL (SINGLE PHASE)		14-15
6305	SANICUBIC 2 XL (THREE PHASE)		16-17
6106	SANIFOS 110 (SINGLE PHASE)		20
6107	SANIFOS 250 (SINGLE PHASE)		20
6108	SANIFOS 500 (SINGLE PHASE)		21
6308	SANIFOS 500 (THREE PHASE)		22
6109	SANIPUMP		23



			ACCESSORIES
1107	4"/100mm ISOLATING VALVE		24
1109	2"/50mm ISOLATING VALVE		24
1108	CARBON AIR FILTER		24

Saniflo works where convention doesn't.

Because Saniflo products are perfect for unconventional situations where drainage is a problem, you'll be able to say 'yes' to your customers more often. More jobs each month and more revenue for your business.

A bath in the basement, a loo in the loft or a shower under the stairs! Wherever you need access to conventional drainage but there's none close by, Saniflo probably has a product to help you find a solution.

Having brought the macerator concept to the UK almost 40 years ago, we now have a huge range of over 30 products including macerator pumps, lifting stations and integrated sanitaryware; all designed to work with small bore pipework that's easy to install and run to the nearest soil pipe. You'll find they're now very quiet and unobtrusive in operation and with many slim-line models available; easy to hide away.

All our products are designed and manufactured in France and rigorously tested in our factory. We have a wealth of experience in the market – 55 years of continuous development and testing goes into each device – constantly refining and improving our products and we're so confident in their reliability they're **guaranteed for 2 years**.

Saniflo UK also has a national network of over **100 service engineers** available to your customers supporting the product day in day out, meaning worry free installation for plumbers and end users.

All you need to do is think of the possibilities.

Our guarantee

Saniflo units are fully guaranteed for up to five years and backed by a nationwide service network of skilled and experienced engineers, see page 28 in 'Pumps and Macerators'.

Technical Advice / Spares: 020 8842 0033

Service Engineer Linkline: 0345 765 0011

Please phone from a landline from the unit location in order to be connected to your local service engineer.

Visit our official website www.repairs.saniflo.co.uk for a full listing of service engineers by geographical area.

Our pumping systems are designed for the disposal of normal organic waste product, water or paper. They are not intended to replace kitchen waste or sanitary waste disposal units. As our policy is one of continuous improvement we reserve the right to alter product specification and price without notice. All information in this publication is given in good faith. No responsibility can be accepted for any errors, omissions or incorrect assumptions. Illustrations are diagrammatic and should be regarded only as indicative of technical requirements. All vertical pumping distances are measured from base of unit.

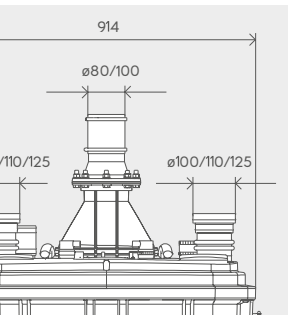
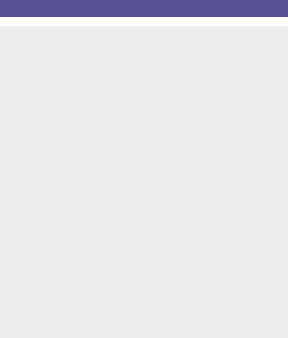

COMMERCIAL

THE (R)EVOLUTION CONTINUES

SANIFLO: PLUMBING THE POSSIBILITIES SINCE 1958

- Removable motors and water level indicators for easy servicing and maintenance
- Positioning, inlet and discharge pipework remain the same
- Easy to disassemble and reassemble

OUR COMMERCIAL RANGE – EVEN MORE INNOVATIVE FOR EASE OF USE

NEW for commercial installations



SANICUBIC® 1
See page 08



SANICUBIC® 2 Pro
See page 10

SANICUBIC® 2 Classic
See page 12



SANICUBIC® 2 XL
SINGLE PHASE
See page 14

AVAILABLE Q3 2017
SANICUBIC® 2 XL
THREE PHASE
See page 16

Tough conditions require tough products and the Saniflo commercial range now has 14 products that are robust enough to perform in some of the most demanding situations.

Having manufactured Saniflo products for over 55 years, no other manufacturer has the years of experience and expertise to produce such a comprehensive range of units for commercial applications.

Think of the possibilities...

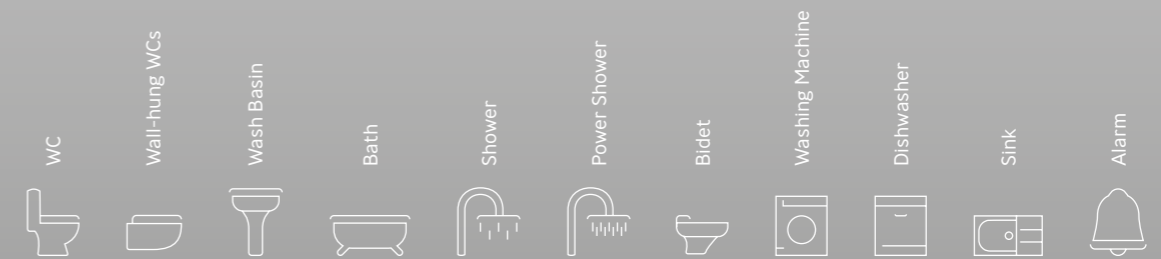
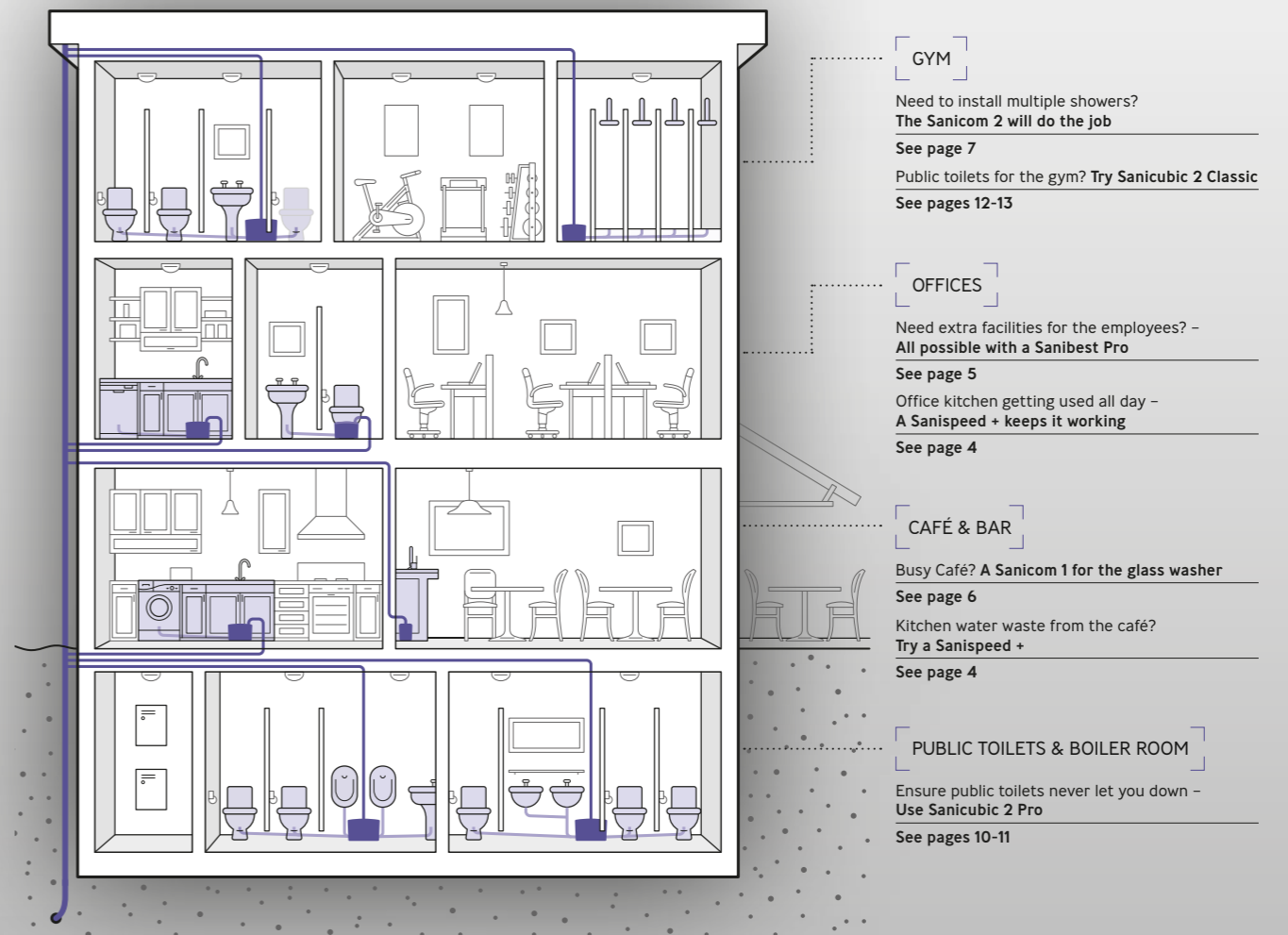

Products suitable for a whole variety of applications. (Just refer to each of the product keys on the relevant pages).

Product Ref: 6045

Ideal for light commercial environments such as small shops, cafés, offices, bars and dental surgeries where grey waste water needs to be disposed of. Sanispeed®+ deals with grey water from a shower, basin, bath, bidet, washing machine, dishwasher and sink.



Why choose this product?

- Ideal for light commercial applications
- Low activation level (95mm)
- Robust motor
- Four inlets – two side entries and two cover entries
- Working temperature of 35°C.
- Will handle up to 75°C for short periods
- Meets European standard EN12050-2
- Carbon filter included to neutralise odours

Vertical/horizontal performance

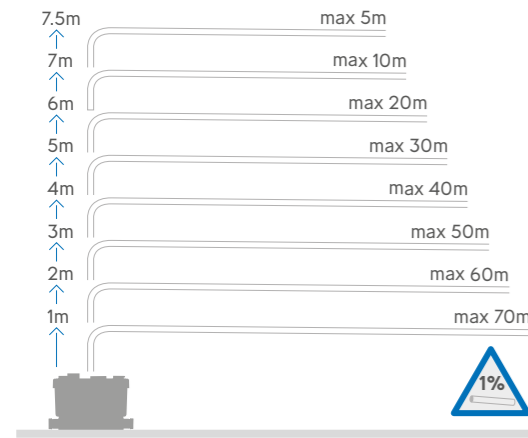

5 YEAR WARRANTY
Up to 5 years warranty
See page 27 of 'Pumps and Macerators' section



NEW

Product Ref: 1053

Sanibest® Pro is a heavy duty macerator suitable for heavy usage public or commercial environments. Handles connection to a WC, basin, bidet and shower.



Why choose this product?

- Ideal for heavy usage applications
- Three inlets – two side entries and one cover entry
- Working temperature of 35°C
- Meets European standard EN12050-3

Vertical/horizontal performance

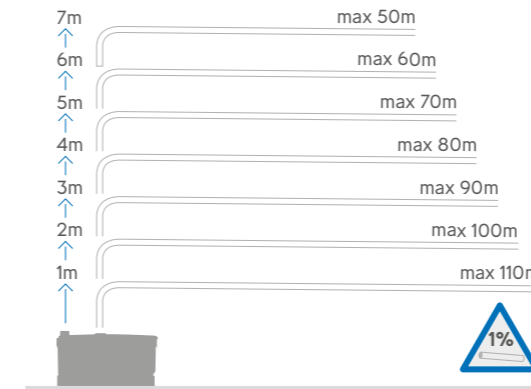

Cover allows easy access to electronic components



Robust blade suitable for heavy usage

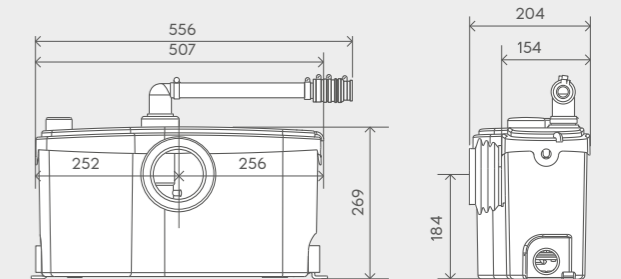

Discharge Pipework
32mm

Motor Power
1100 Watts

Voltages
220-240 V/50 Hz

Working Waste Water Temp
35°C

Product Weight
35kg

Inlet Pipework
40mm

IP Rating
IP44

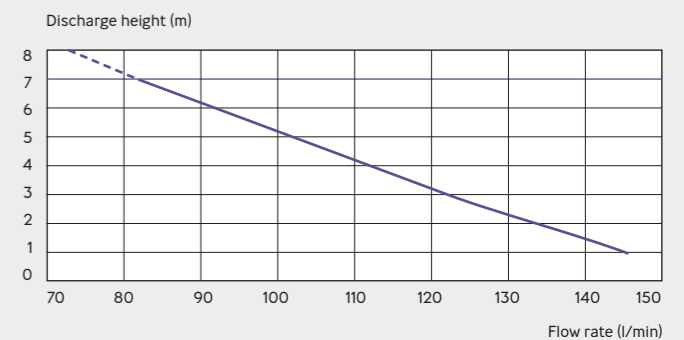

Product Ref: 1046/1

Sanicom® 1 is an automatic, powerful lifting station for grey water used in busy commercial environments. Suitable for multiple connections including a basin, bath, shower, bidet, sink, dishwasher and washing machine.



Why choose this product?

- Ideal for commercial applications e.g. cleaning and catering sinks
- Heavy duty, safe, reliable pump
- Unit operates automatically
- Two 40mm side entries and air vent/connection to exterior
- Working temperature of 35°C
- Will handle up to 90°C for short periods

Vertical/horizontal performance

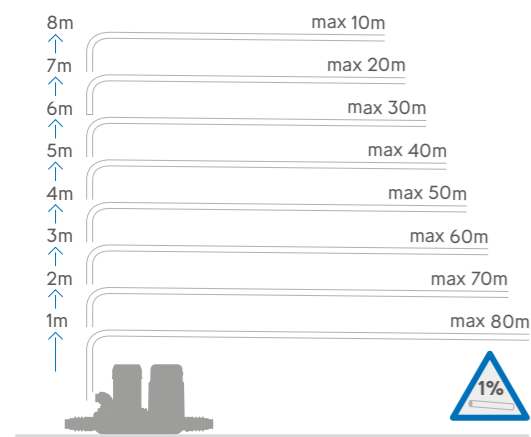

Connection to soil and vent pipe or drain

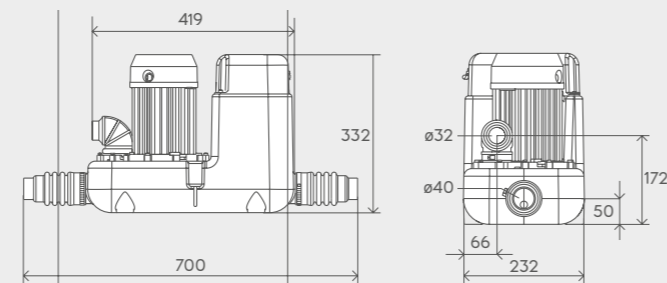
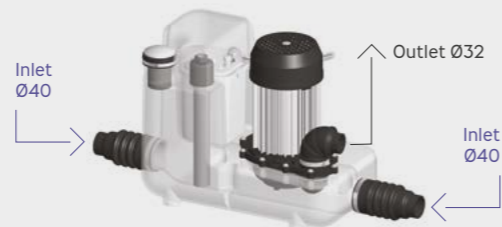
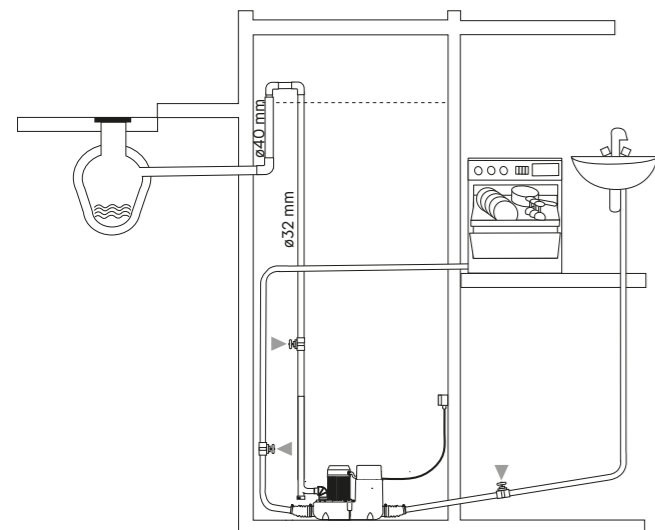

Discharge Pipework 32mm	Working Waste Water Temp 35°C/Max 90°C (intermittent)
Motor Power 750 Watts	Product Weight 12kg
Voltages 220-240 V/50 Hz	Inlet Pipework 40mm
Tank Volume 10L	IP Rating IP44

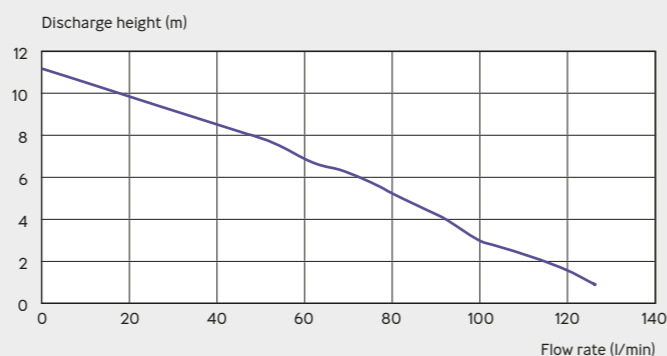

Product Ref: 1046/2

Identical to Sanicom® 1 but features two powerful motors where the second motor is a failsafe back-up to ensure that you always have continuity of service for your business.



Why choose this product?

- Ideal for heavy commercial applications
- Safe, reliable pump plus backup motor
- Unit operates automatically
- Two 40mm side entries and air vent/connection to exterior
- Working temperature of 35°C
- Will handle up to 90°C for short periods
- External hard-wired alarm

Vertical/horizontal performance

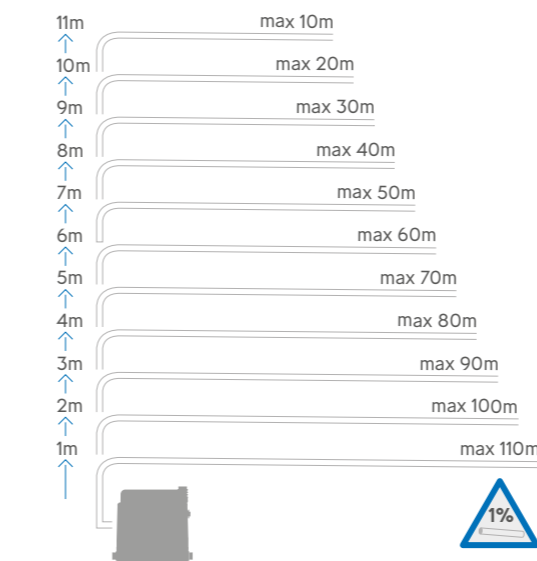

Connection to soil and vent pipe or drain

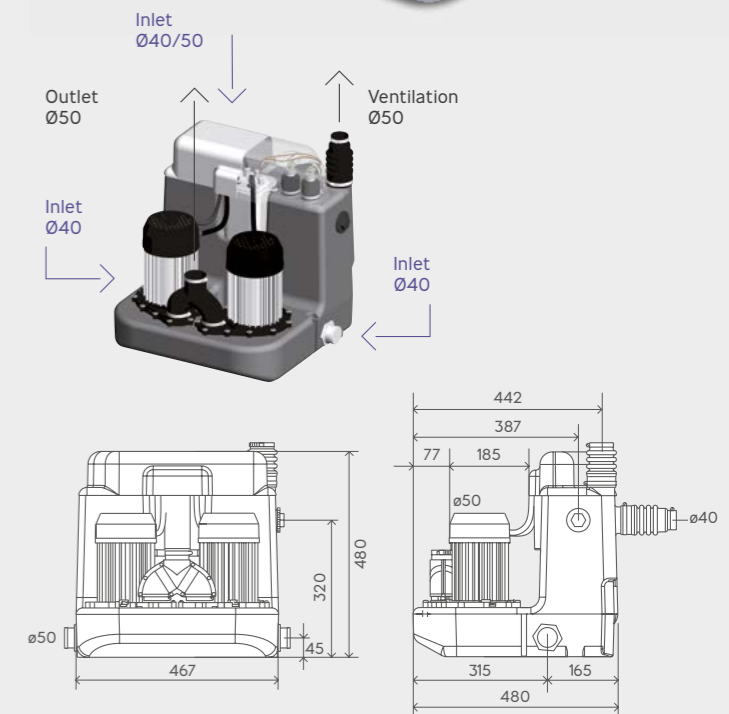
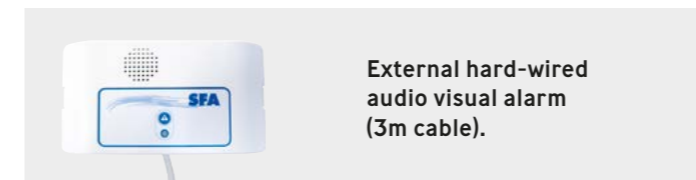
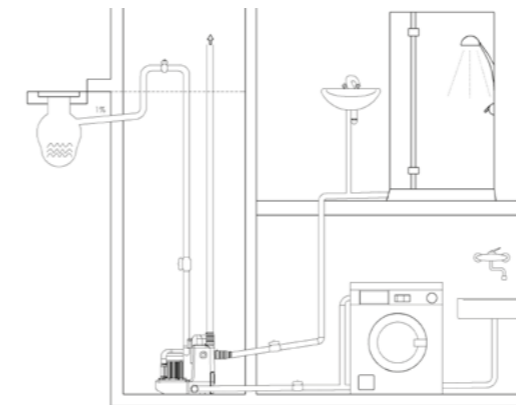

Discharge Pipework 50mm	Working Waste Water Temp 35°C/Max 90°C (intermittent)
Motor Power 1500 Watts x 2	Product Weight 26kg
Voltages 220-240 V/50 Hz	Inlet Pipework 40 / 50mm
Tank Volume 34.5L	IP Rating IP44

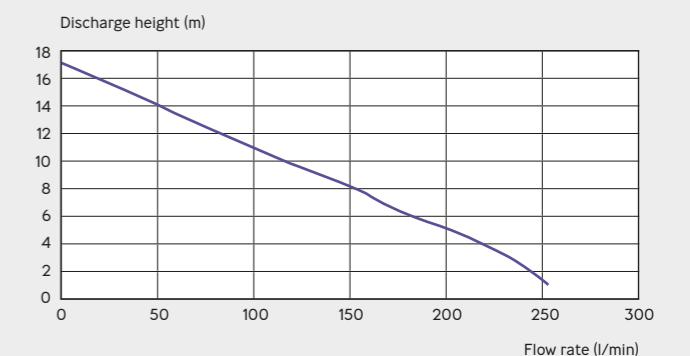

The Sanicubic® 1 is a robust macerator pump that has been designed for the discharge of waste from up to two WCs plus multiple grey water producing appliances in busy business environments and larger domestic situations.

AVAILABLE
Q2 2017



Note: Isolation valves must be fitted to the inlet pipework and discharge pipework to isolate the unit in case of the need for service
- see page 23

Why choose this product?

- Ideal for busy business environments and larger domestic situations
- Tough, reliable macerator pump
- New design with easily removable motor for servicing and maintenance
- Water level indicator unit can be easily removed for maintenance
- External hard wired audio visual alarm
- Features integrated non-return valves
- Centre heights of inlets 140mm
- Working temperature of 35°C. Will handle up to 70°C for short periods. (See Sanicom 1 and 2 for higher temperatures and longer periods)
- IP67 rated
- Cannot be connected to a Building Management System

Vertical/horizontal performance

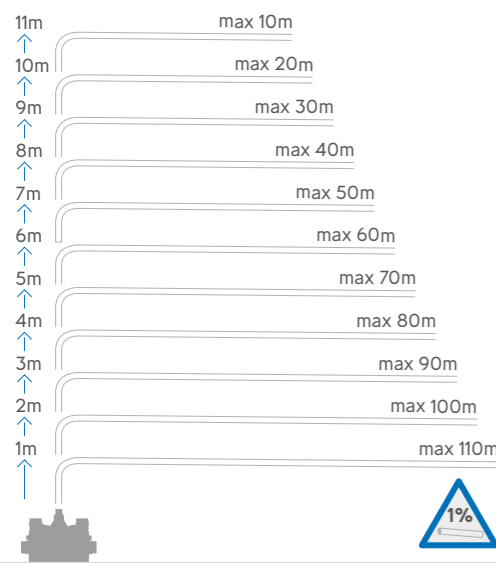

The Sanicubic tank is fitted with 2 dip tubes; one tube controls motor operation and the other controls the alarm system:

- Long pickup tube (normal operation): as soon as the waste water level in the tank reaches the triggering point in the long tube, the pumping system starts up.
- Short pickup tube (inflow overload operation): if the waste water level in the tank reaches the upper point, a contact is closed and the auxiliary pumping system is triggered. The contact also sets off an audible and visual alarm.

IP Ratings

IP or "Ingress Protection" ratings specify the environmental protection that the product casing provides and are defined by international standards. They are used to explain levels of sealing effectiveness of electrical enclosures against intrusion from foreign bodies e.g. dust, dirt and moisture.

Sanicubic 1 has rating IP67 which gives protection against temporary immersion in water.

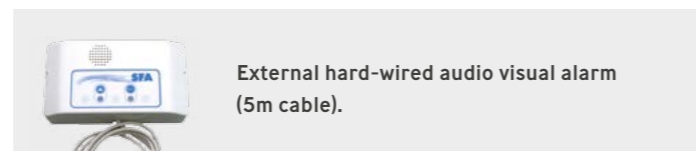

Discharge Pipework 50mm	Working Waste Water Temp 35°C/Max 70°C (intermittent)
Motor Power 1500 Watts	Product Weight 20kg
Flow Rate 13m³/h	Inlet Pipework 40 / 50 / 100 / 110mm
Voltages 220-240 V/50 Hz	IP Rating IP67
Tank Volume 32L	

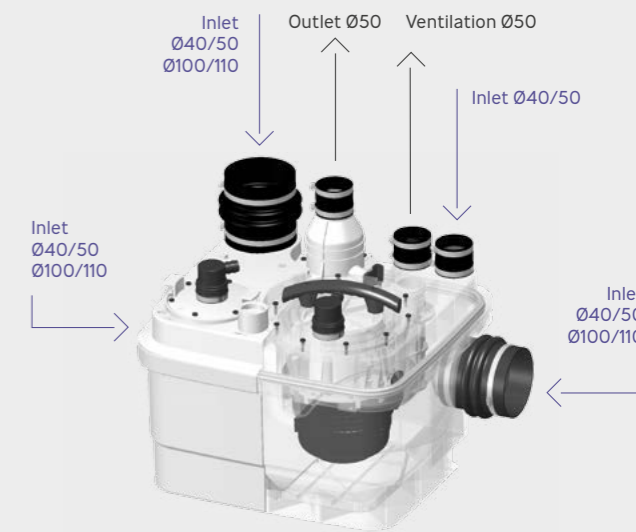
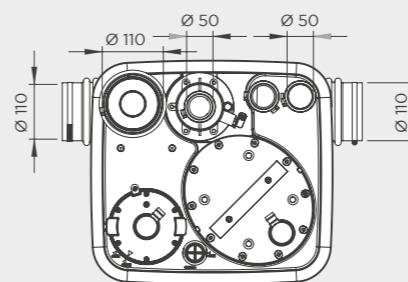
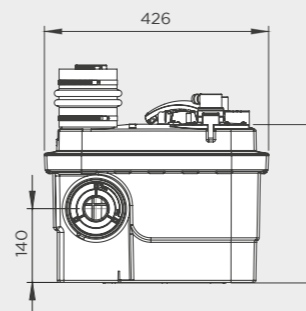
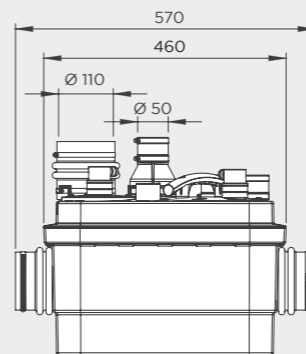
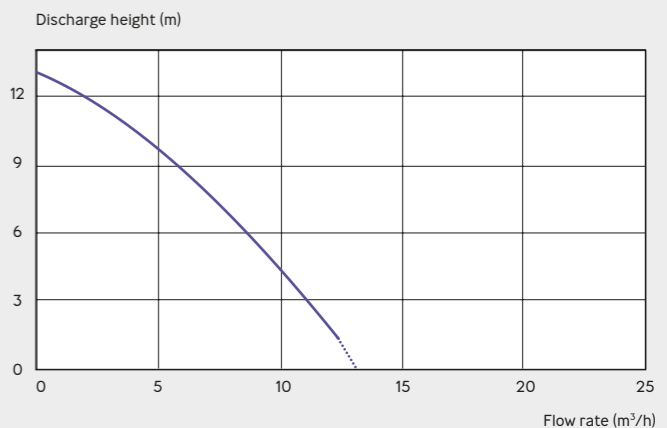

Remote hard-wired audio visual alarm



The Sanicubic® 2 Pro is a high performance macerating pump for commercial use. Contains two separate, load balanced pumps with high performance macerating systems and will operate alternately. In the event of inflow overload, both motors run at the same time, or in the unlikely event that one motor fails, the other one will take over.



Note: Isolation valves must be fitted to the inlet pipework and discharge pipework to isolate the unit in case of the need for service – see page 23

Why choose this product?

- Ideal for busy business environments and larger domestic situations
- Tough, reliable macerator pump
- New design with easily removable motor for servicing and maintenance
- Water level indicator unit can be easily removed for maintenance
- Load balanced twin macerator pumps for a failsafe system
- Alternate activation ensures even wear of motors
- Two alarms for ultimate safety – hard-wired alarm plus remote wireless alarm
- Centre height of inlets 140mm
- Working temperature of 35°C. Will handle up to 70°C for short periods. (See Sanicom 1 and 2 for higher temperatures and longer periods)
- IP68 rated
- Can be connected to a Building Management System.

Vertical/horizontal performance

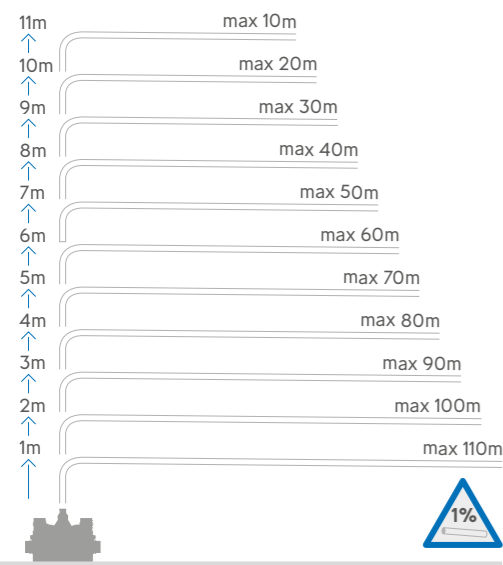

The Sanicubic tank is fitted with 2 dip tubes; one tube controls motor operation and the other controls the alarm system:

- Long pickup tube (normal operation): as soon as the waste water level in the tank reaches the triggering point in the long tube, the pumping system starts up.
- Short pickup tube (inflow overload operation): if the waste water level in the tank reaches the upper point, a contact is closed and the auxiliary pumping system is triggered. The contact also sets off an audible and visual alarm.

IP Ratings

IP or "Ingress Protection" ratings specify the environmental protection that the product casing provides and are defined by international standards. They are used to explain levels of sealing effectiveness of electrical enclosures against intrusion from foreign bodies e.g. dust, dirt and moisture.

Sanicubic 2 Pro has rating IP68 which gives protection against continuous submersion in water



Includes hard-wired alarm on externally mounted control box plus secondary high frequency remote wireless alarm.

Discharge Pipework

50mm

Motor Power

1500 Watts x 2

Flow Rate

13m³/h

Voltages

220-240 V/50 Hz

Tank Volume

45L

Working Waste Water Temp

35°C/Max 70°C (Intermittent)

Product Weight

33kg

Inlet Pipework

40 / 50 / 100 / 110mm

IP Rating

IP68

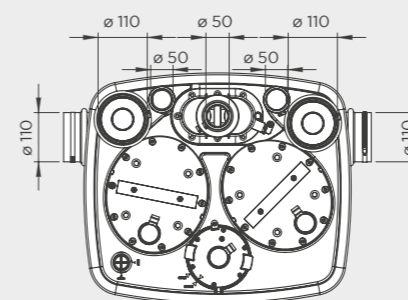
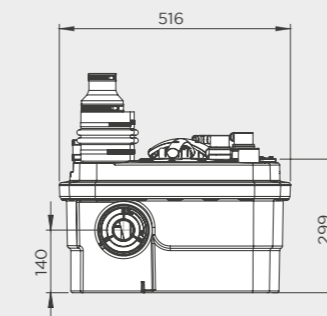
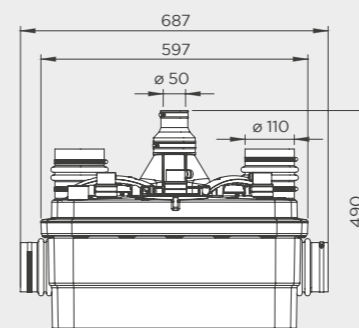

Discharge height (m)

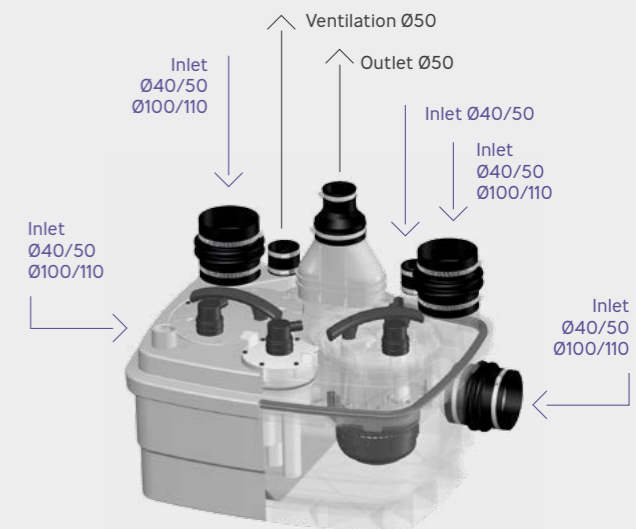
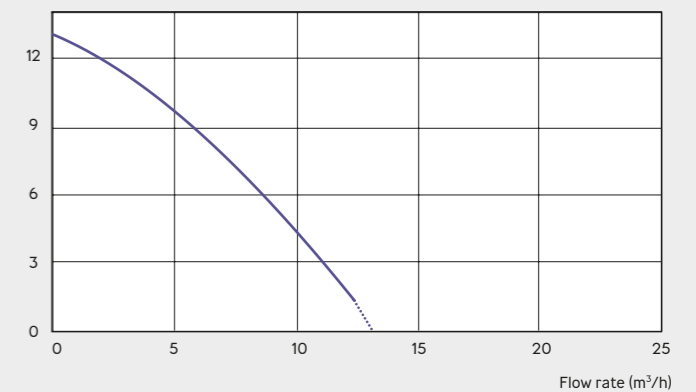

Externally mounted control box

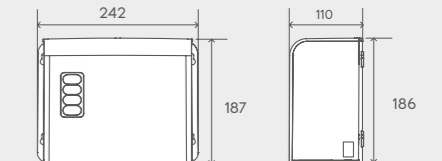
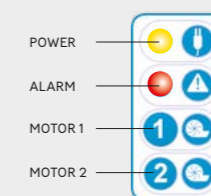

Remote wireless alarm

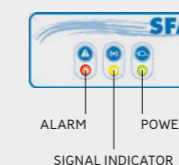

The Sanicubic® 2 Classic contains two separate, load balanced pumps with high performance macerating systems and will operate alternately. In the event of inflow overload, both motors run at the same time, or in the unlikely event that one motor fails, the other one will take over.

Why choose this product?

- Ideal for busy business environments and larger domestic situations
- Tough, reliable macerator pump
- New design with easily removable motor for servicing and maintenance
- Water level indicator unit can be easily removed for maintenance
- Load balanced twin macerator pumps for a failsafe system
- Alternate activation ensures even wear of motors
- Two alarms for ultimate safety – both hard-wired
- Centre heights of inlets 140mm
- Working temperature of 35°C. Will handle up to 70°C for short periods. (See Sanicom 1 and 2 for higher temperatures and longer periods)
- IP68 rated
- Can be connected to a Building Management System



Note: Isolation valves must be fitted to the inlet pipework and discharge pipework to isolate the unit in case of the need for service – see page 23

Vertical/horizontal performance

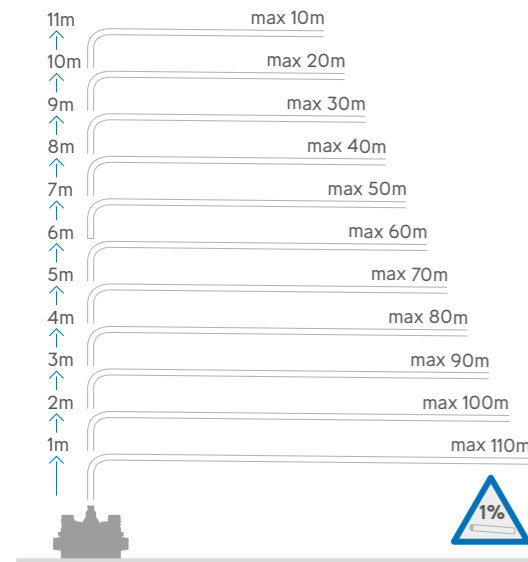

The Sanicubic tank is fitted with 2 dip tubes; one tube controls motor operation and the other controls the alarm system:

- Long pickup tube (normal operation): as soon as the waste water level in the tank reaches the triggering point in the long tube, the pumping system starts up.
- Short pickup tube (inflow overload operation): if the waste water level in the tank reaches the upper point, a contact is closed and the auxiliary pumping system is triggered. The contact also sets off an audible and visual alarm.

IP Ratings

IP or "Ingress Protection" ratings specify the environmental protection that the product casing provides and are defined by international standards. They are used to explain levels of sealing effectiveness of electrical enclosures against intrusion from foreign bodies e.g. dust, dirt and moisture.

Sanicubic 2 Classic has rating IP68 which gives protection against continuous submersion in water.



Includes hard-wired alarm on externally mounted control box plus secondary hard-wired audio visual alarm with 5m cable, so it can be placed remotely.

Discharge Pipework 50mm	Working Waste Water Temp 35°C/Max 70°C (Intermittent)
Motor Power 1500 Watts x 2	Product Weight 36kg
Flow Rate 13m³/h	Inlet Pipework 40 / 50 / 100 / 110mm
Voltages 220-240 V/50 Hz	IP Rating IP68
Tank Volume 45L	

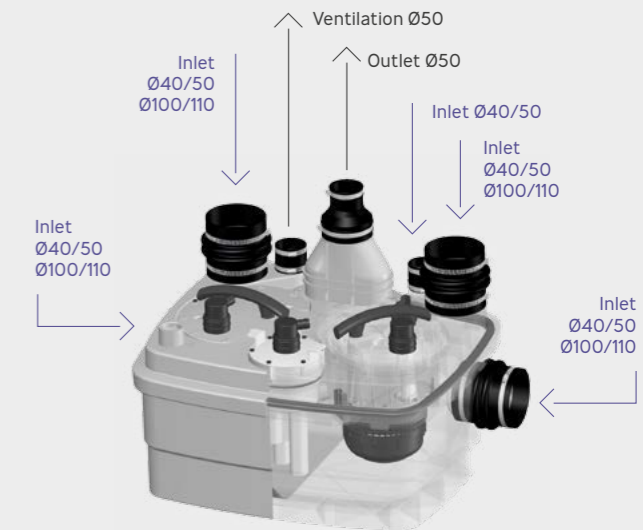
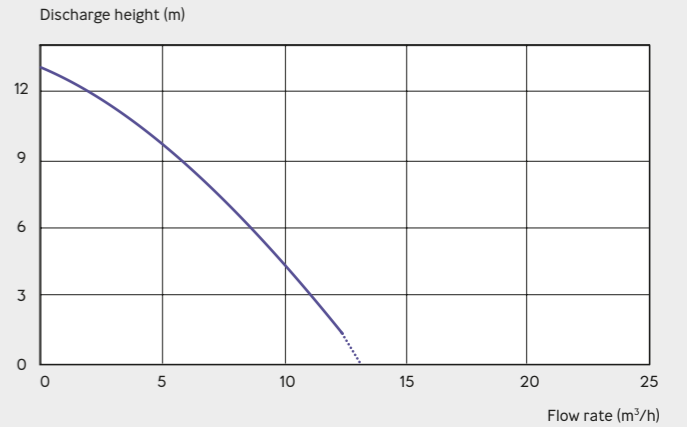
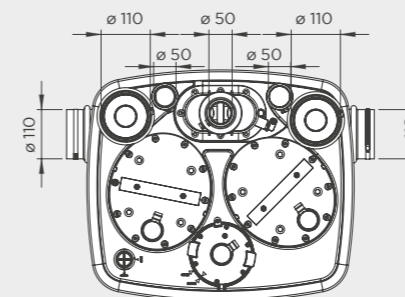
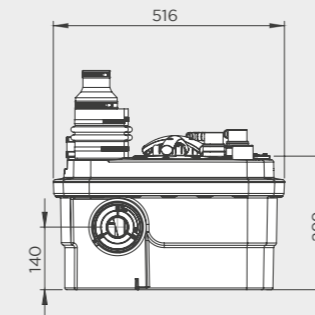
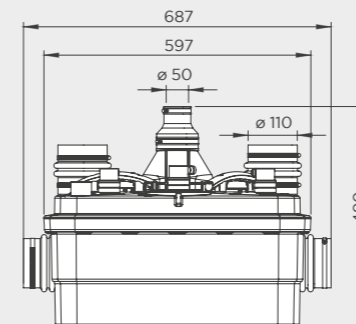

Externally mounted control box

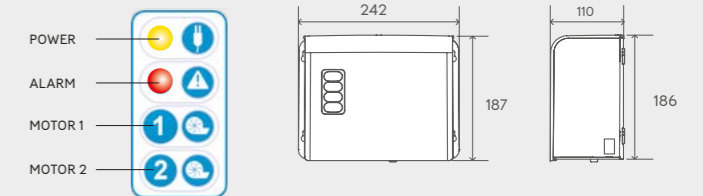

Remote wireless alarm

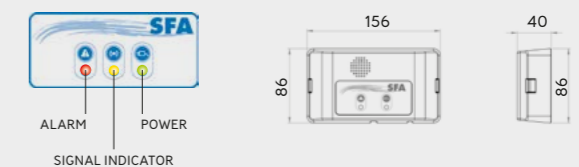

SANICUBIC® 2 XL

SINGLE PHASE

Product Ref: 6105

The Sanicubic® 2 XL is one of our largest lifting stations for commercial use handling up to 40m³/hour of black water via two 2kW pumps. It is easy to install as it stands on the floor and does not need to be positioned below ground.



Note: Isolation valves must be fitted to the inlet pipework and discharge pipework to isolate the unit in case of the need for service – see page 23

Why choose this product?

- Ideal for large volume commercial situations
- Large bore vortex pump which can pump away waste without the need to macerate
- Easily removable motors for servicing and maintenance
- Large 120 litre tank volume
- Easy to install – no need to excavate
- Two alarms for ultimate safety – both hard-wired
- Two integrated non-return valves and four inlets: 40/50/100/110mm and one inlet 40/50mm
- Centre height of inlets 180mm
- Working temperature of 35°C. Will handle up to 70°C for short periods. (See Sanicom 1 and 2 for higher temperatures and longer periods)
- IP68 rated
- Volt free contact for connection to a Building Management System

Vertical/horizontal performance

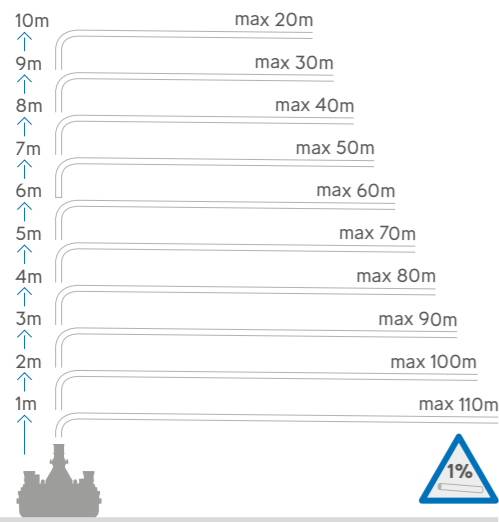

Max pumping height 13m at 0 flow rate



IP Ratings

IP or "Ingress Protection" ratings specify the environmental protection that the product casing provides and are defined by international standards. They are used to explain levels of sealing effectiveness of electrical enclosures against intrusion from foreign bodies e.g. dust, dirt and moisture.

Sanicubic 2 XL has rating IP68 which gives protection against continuous submersion in water.



Includes hard-wired alarm on externally mounted control box plus secondary hard-wired audio visual alarm with 5m cable, so it can be placed remotely.

Discharge Pipework
100 mm up to 6m/ 80mm thereafter

Motor Power
2000 Watts x 2

Flow Rate
40m³/h

Voltages
220-240 V/50 Hz

Tank Volume
120L

Working Waste Water Temp
35°C/Max 70°C (Intermittent)

Product Weight
59kg

IP Rating
IP68

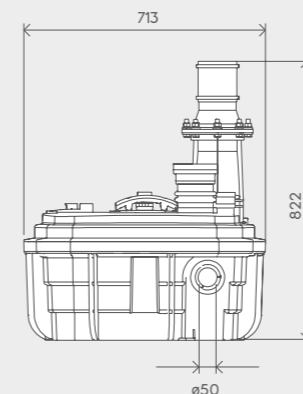
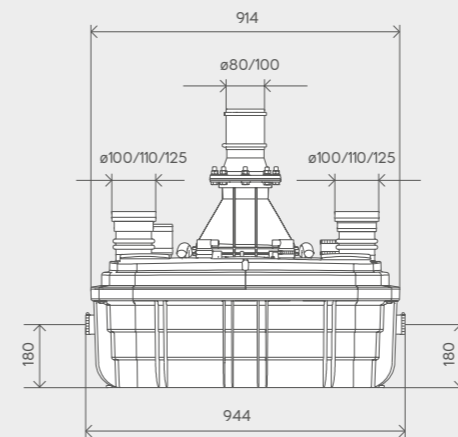
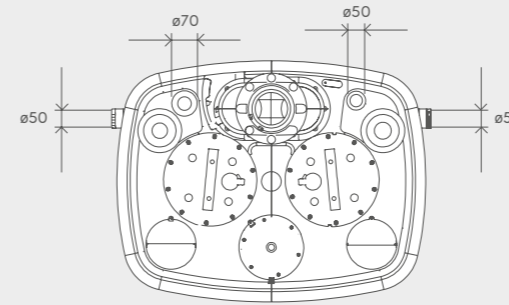

Discharge height (m)

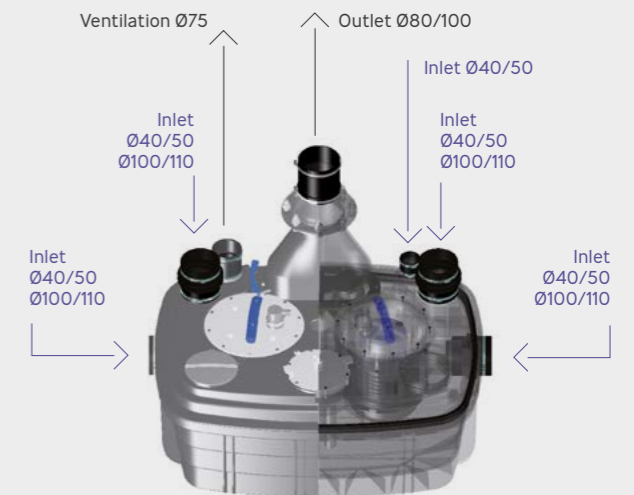
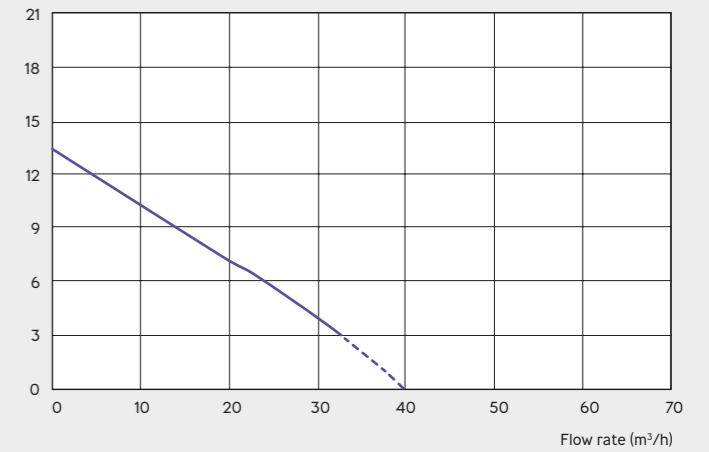

Externally mounted control box

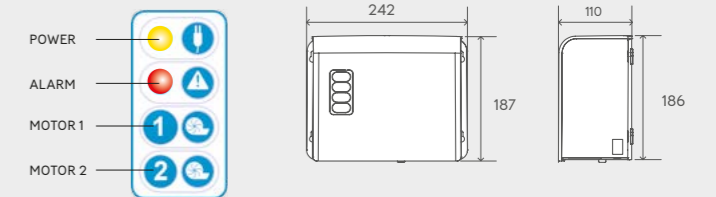

Remote hard-wired audio visual alarm



SANICUBIC® 2 XL

THREE PHASE

Product Ref: 6305

The Sanicubic® 2 XL is one of our largest lifting stations for commercial use handling up to 55m³/hour of black water via two 3200W pumps. It is easy to install as it stands on the floor and does not need to be positioned below ground.



Note: Isolation valves must be fitted to the inlet pipework and discharge pipework to isolate the unit in case of the need for service – see page 23

Why choose this product?

- Ideal for large volume commercial situations
- Large bore vortex pump which can pump away waste without the need to macerate
- Easily removable motors for servicing and maintenance
- Large 120 litre tank volume
- Easy to install – no need to excavate
- Two alarms for ultimate safety – both hard-wired
- Two integrated non-return valves and four inlets: 40/50/100/110mm and one inlet 40/50mm
- Centre height of inlets 180mm
- Working temperature of 35°C. Will handle up to 70°C for short periods. (See Sanicom 1 and 2 for higher temperatures and longer periods)
- IP68 rated
- Volt free contact for connection to a Building Management System

Vertical/horizontal performance

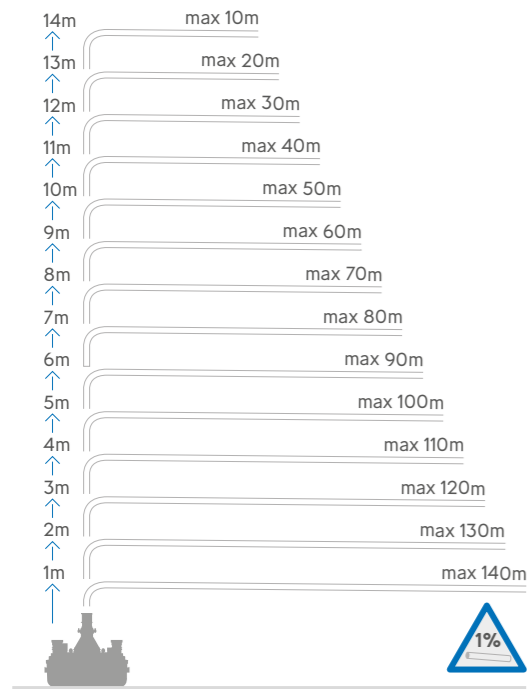

Max pumping height 16m at 0 flow rate

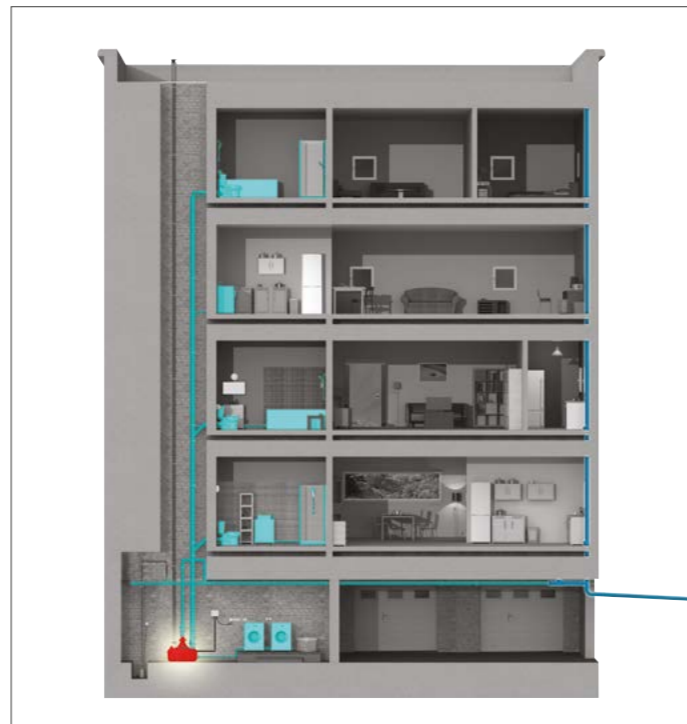

Discharge Pipework
100 mm up to 6m/ 80mm thereafter

Motor Power
3200 Watts x 2

Flow Rate
55m³/h

Voltages
230-400 V/50 Hz

Tank Volume
120L

Working Waste Water Temp
35°C/Max 70°C (Intermittent)

Product Weight
60kg

IP Rating
IP68

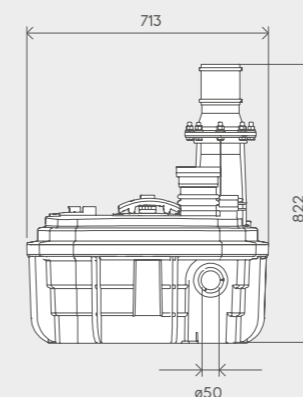
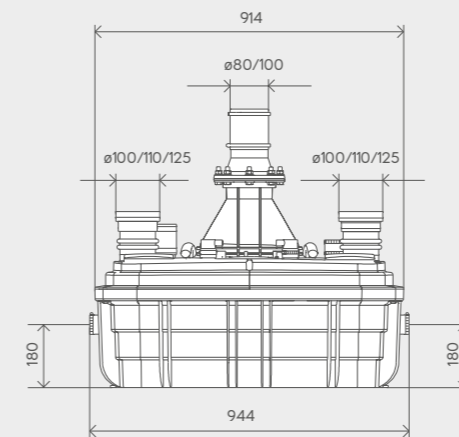
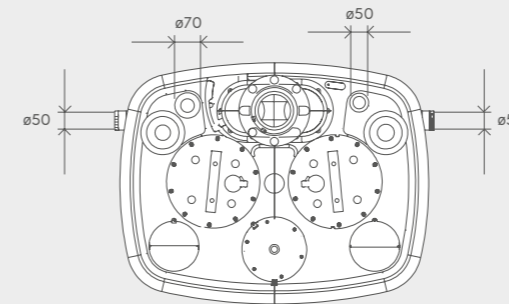

Discharge height (m)

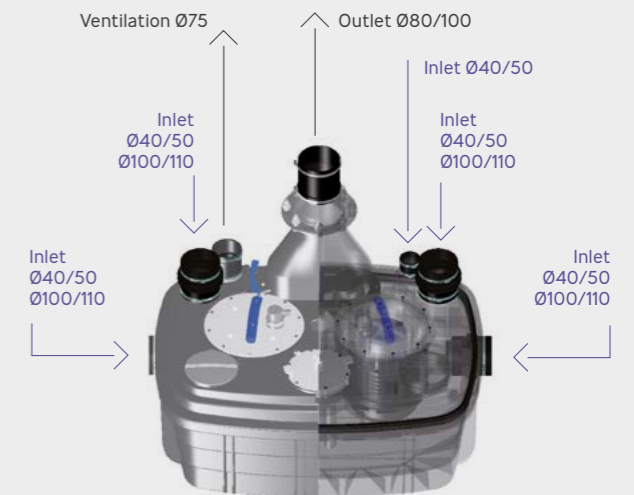
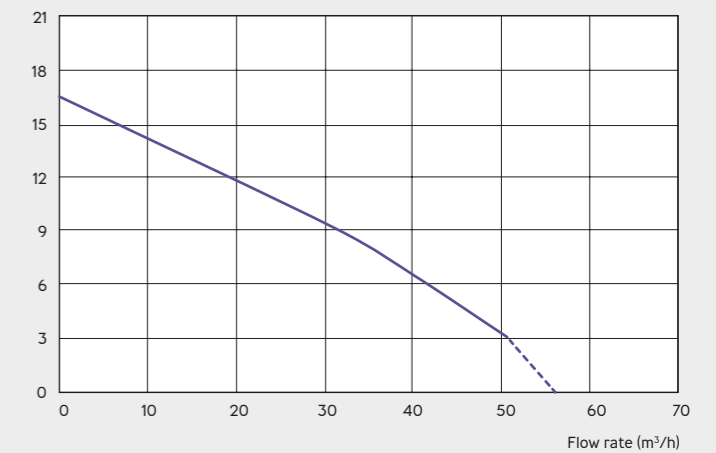

Externally mounted control box

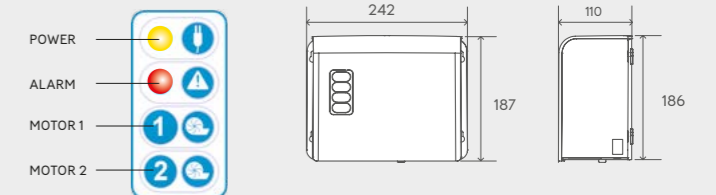

Remote hard-wired audio visual alarm



UNDERGROUND PUMP STATIONS

THE (R)EVOLUTION CONTINUES

ALLOWS A PUMPING STATION TO BE SITED:

- Below ground
- External to a building
- Where the drainage is too low for the sewer
- Where the drainage is too low for a surface mounted pumping station

NEW for Q3 2017

Automatic underground pumping stations for the collection and lifting of domestic sewerage and waste water



SANIFOS® 250
SINGLE PHASE
See page 20

SANIFOS® 500
SINGLE PHASE
See page 21
THREE PHASE
See page 22

- Sanifos range has both one and two pump products
- Single and three phase versions
- Powerful automatic motors with quiet operation
- Easy handling for installation below ground level



SANIFOS® 110
SINGLE PHASE
See page 20

SANIPUMP®
See page 23

- Waste water pump with cutting system
- Externally fitted float switch
- Quiet operation



With over **55 years of designing and manufacturing** both domestic and commercial macerators and pumps, Saniflo has all the credentials to produce our **new range of underground pump stations**.

New for 2017, this range includes our submersible drainage pump and our largest lifting stations that can be used for pumping residential and commercial waste water from flats, plants or public buildings.

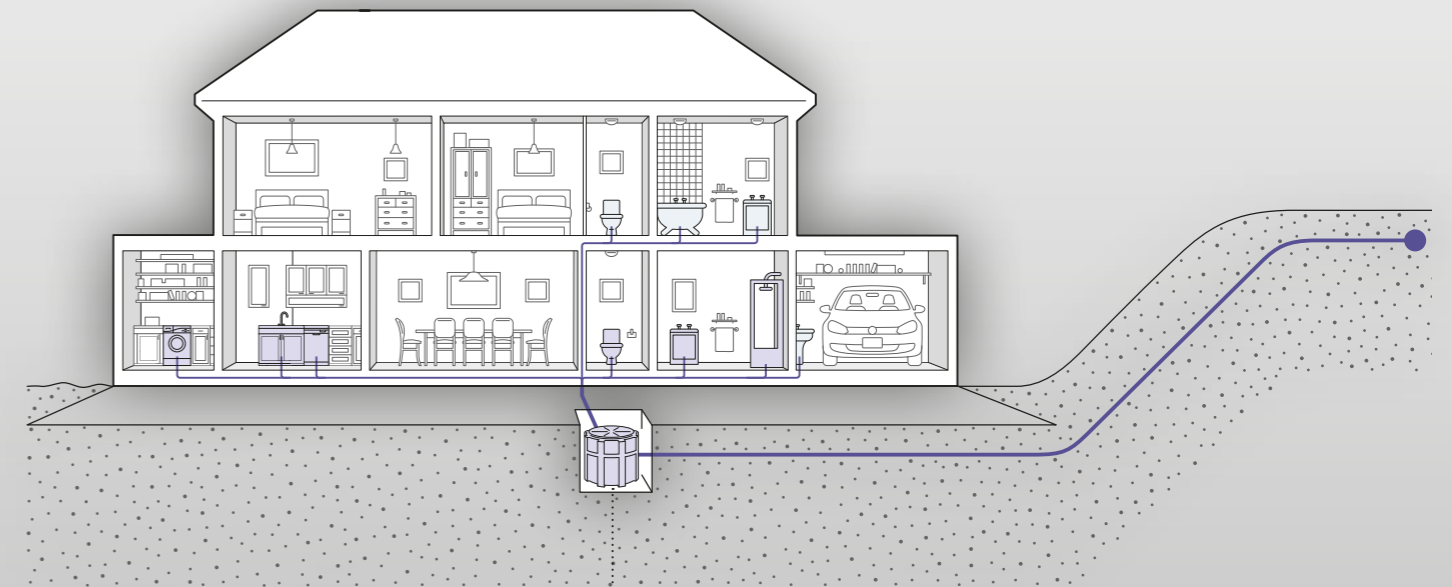

WHOLE HOUSE DRAINAGE WITH HIGH LEVEL SEWER

Multiple applications with maximum use? **The Sanifos 500 will cope with this no problem, and give you peace of mind with twin motors.**

See pages 21 and 22

Fewer applications and less use? **The Sanifos 250 will do the job.**

See page 20

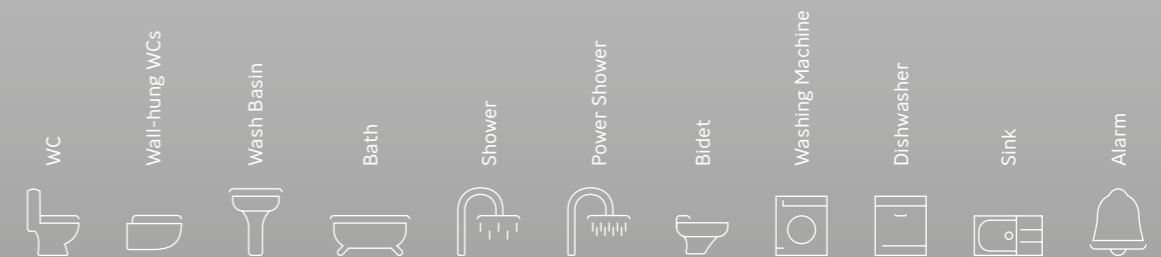

Products suitable for a whole variety of applications. (Just refer to each of the product keys on the relevant pages).

SANIFOS® 110/250

SINGLE PHASE

Product Ref: 6106/6107

An automatic lifting station that can be used for pumping residential or industrial waste water when the sewer is at too high a level for natural gravity drainage.



Sanifos 250

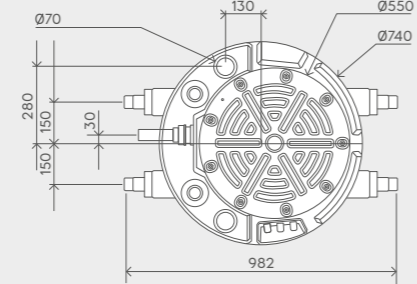
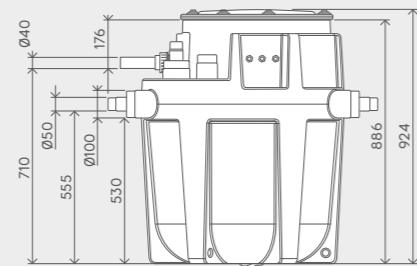

Discharge Pipework
40 / 50mm

Motor Power
1500 Watts

Voltages
220-240 V/50 Hz

Tank Volume
110L / 250L

Working Waste Water Temp
70°C (max 5 minutes)

Flow Rate
11m³/hour

Inlet Pipework
50 / 40 / 100 / 110 / 125mm

IP Rating
IP68

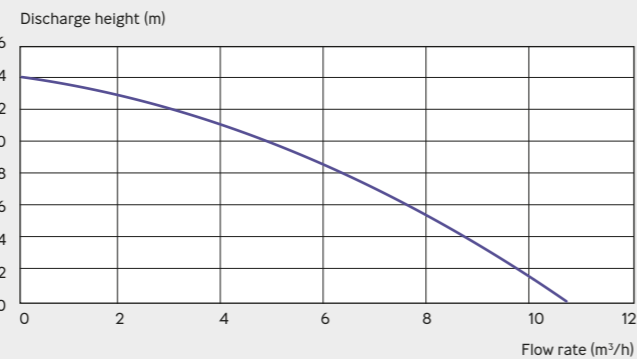

Why choose this product?

- Designed for drainage of a single dwelling incorporating WC, bathroom, kitchen, utility room.
- Single grinder pump with float activation method
- Robust cutting blades to prevent clogging
- Two sizes: 110 litre and 250 litre storage tanks
- Powerful automatic motor with quiet operation
- Easy handling for installation below ground level

Vertical/horizontal performance

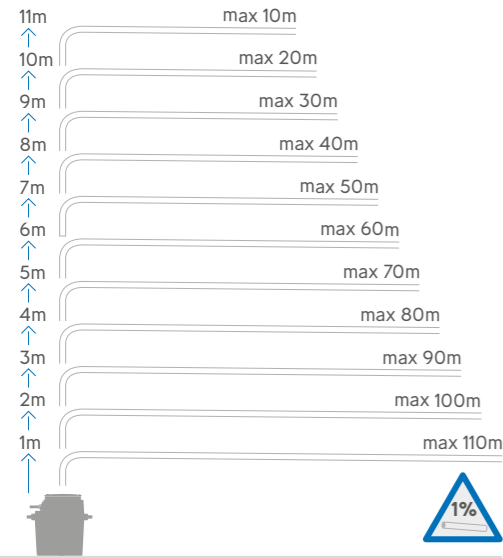

Max pumping height 14m at 0 flow rate



SANIFOS® 500

SINGLE PHASE

Product Ref: 6108

A dual motor lifting station that can be used for pumping residential or industrial waste water when the sewer is at too high a level for natural gravity drainage.



Why choose this product?

- Designed for drainage of a single dwelling with multiple storeys, incorporating WC, bathroom, kitchen and utility room.
- Contains two separate load balanced pumps with high performance macerating systems that will operate alternately for a failsafe system.
- In the event of inflow overload, both motors run at the same time, or in the unlikely event that one motor fails, the other one will take over.
- Alternate activation ensures even wear of motors
- Robust cutting blades to prevent clogging
- 500 litre storage tank
- Powerful automatic motors with quiet operation
- Easy handling for installation below ground level

Vertical/horizontal performance

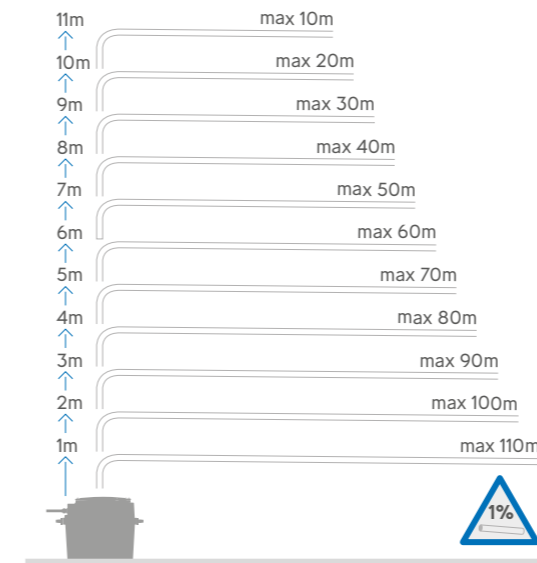

Max pumping height 14m at 0 flow rate



AVAILABLE Q3 2017

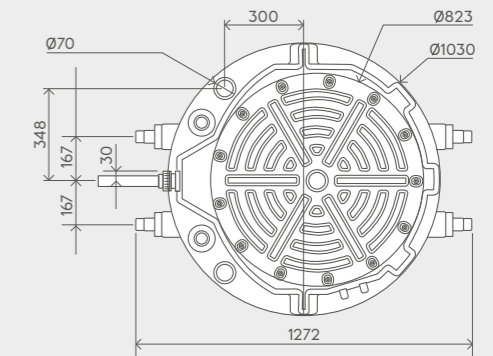
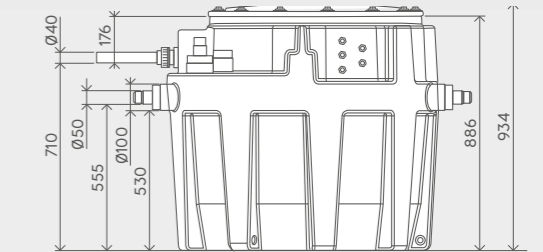

Discharge Pipework
40 / 50mm

Motor Power
1500 Watts x 2

Voltages
220-240 V/50 Hz

Tank Volume
500L

Working Waste Water Temp
70°C (max 5 minutes)

Flow Rate
11m³/hour

Inlet Pipework
50 / 40 / 100 / 110 / 125mm

IP Rating
IP68

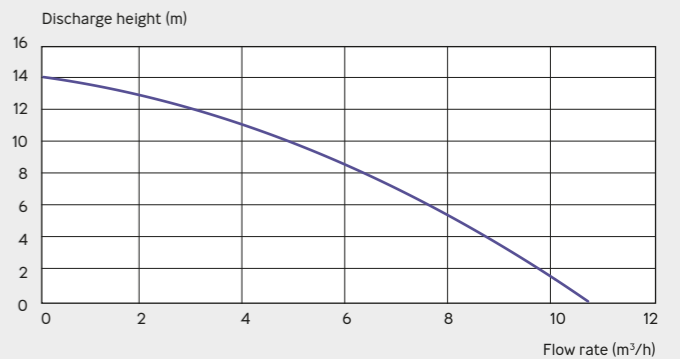

SANIFOS® 500 THREE PHASE

Product Ref: 6308

A dual motor lifting station that can be used for pumping residential or industrial waste water when the sewer is at too high a level for natural gravity drainage.

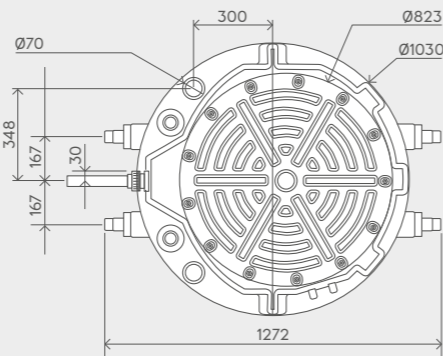
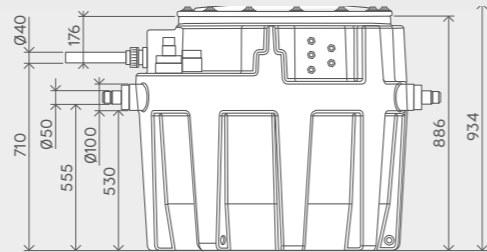

Discharge Pipework
40 / 50mm

Working Waste Water Temp
70°C (max 5 minutes)

Motor Power
5600 Watts x 2

Flow Rate
15.5m³/hour

Voltages
230-240 V/50 Hz

Inlet Pipework
50 / 40 / 100 / 110 / 125mm

Tank Volume
500L

IP Rating
IP68

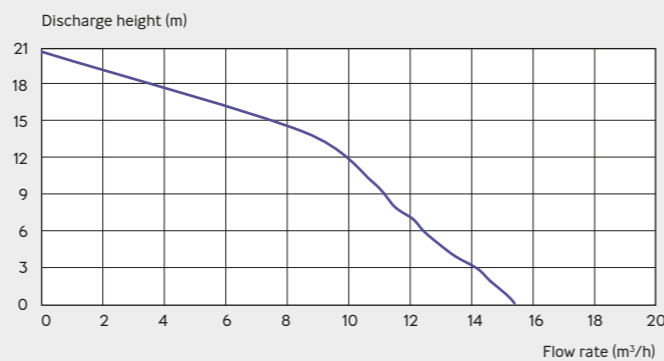

Why choose this product?

- Designed for drainage of a single dwelling with multiple storeys, incorporating WC, bathroom, kitchen and utility room.
- Contains two separate load balanced pumps with high performance macerating systems that will operate alternately for a failsafe system.
- In the event of inflow overload, both motors run at the same time, or in the unlikely event that one motor fails, the other one will take over.
- Alternate activation ensures even wear of motors
- Robust cutting blades to prevent clogging
- 500 litre storage tank
- Powerful automatic motors with quiet operation
- Easy handling for installation below ground level

Vertical/horizontal performance

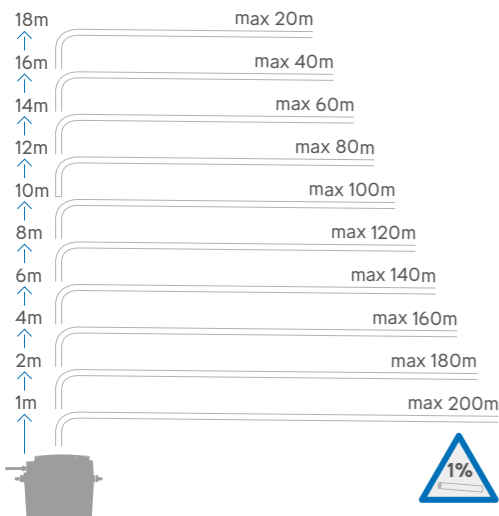

Max pumping height 21m at 0 flow rate



AVAILABLE
Q3 2017

SANIPUMP®

Product Ref: 6109

A submersible sump pump with macerator blades for use in domestic and commercial situations. The ideal solution for waste water and sewage disposal from underground pits and tanks.



Why choose this product?

- Black water pump for use with WC, bathrooms, kitchens and utility rooms
- Can also be used for grey water when pumping away from a pit or flood water situation
- Compact in design, easy to install and ready to use
- Automatic motor with float system activation
- Robust macerator cutting system

Vertical/horizontal performance

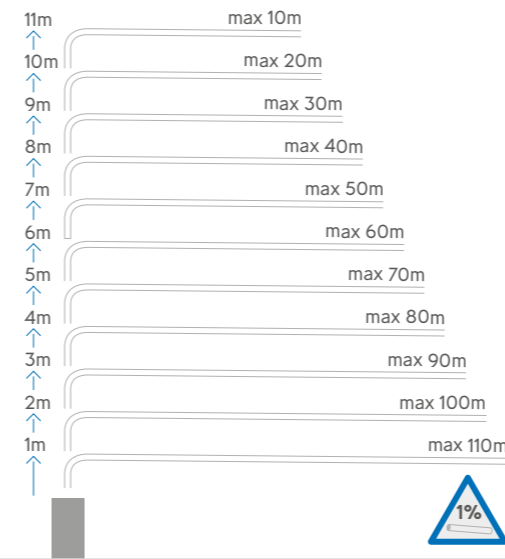

Max pumping height 14m at 0 flow rate



Discharge Pipework
40 / 50mm

Working Waste Water Temp
35°C/Max 70°C (intermittent)

Motor Power
1500W

Flow Rate
11m³/hour

Voltages
220-240 V/50Hz

IP Rating
IP68

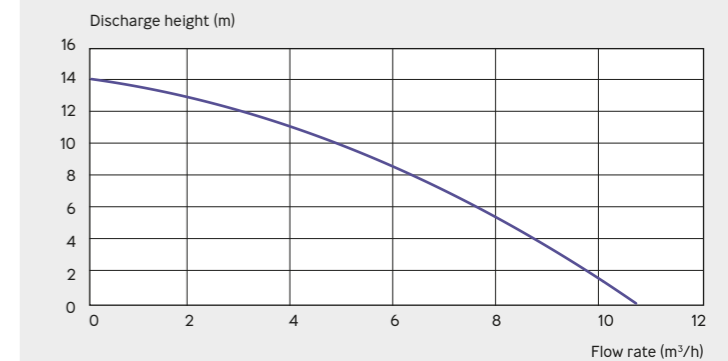

SANIFLO® ISOLATING VALVES

Product Ref: 2" 1109 / 4" 1107

Designed for use with the Sanicubic® range, isolating valves allow you to carry out maintenance on lifting stations easily, quickly and without restrictions.

Available in 2"/50mm and 4"/100mm sizes.

Why choose this product?

- Allows convenient maintenance
- Designed specifically for use with the Sanicubic range



2"/50mm

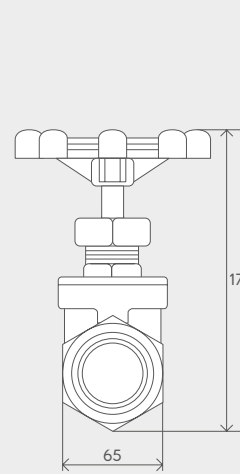

Weight
1.44kg

4"/100mm

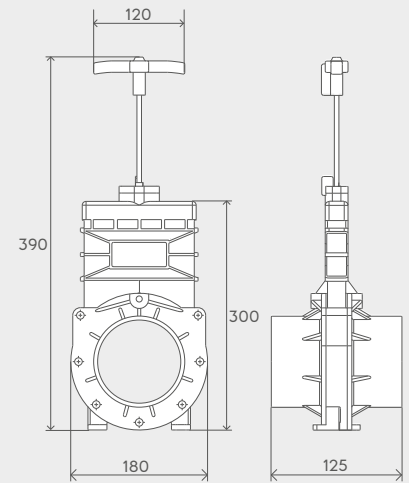

Weight
1.86kg

SANIFLO® CARBON AIR FILTER

Product Ref: 1108

For use with waste water and sewerage pumping systems where a vent to the atmosphere is not possible. Contains an activated carbon filter ideal for removing unpleasant odours and gaseous contaminants from an air stream. Also allows two-way air passage to enable the pump unit to breathe.

Why choose this product?

- Ideal for use with waste water pumping systems where waste water is extremely hot i.e. commercial dishwashers, glasswashers etc.
- Active carbon filter
- Neutralises unpleasant odours
- Allows pump units to breathe



Weight
0.66kg

Dimensions
W 155mm / D 125mm / H125mm