



The **Greenskies** range  
of solar thermal panels



## Worcester and you. Making a difference.

As part of the Bosch Group, Worcester products are designed and manufactured to provide customers with the highest levels of quality and reliability which are synonymous with the Bosch name throughout the world.

As part of Europe's largest supplier of heating products, Worcester, Bosch Group has the UK-based resources and support capability to offer you the value-added solutions you deserve. Worcester employs a nationwide network of Service Engineers and technically trained

Field Sales Managers supported by an experienced technical services team which is able to provide comprehensive support and advice from designing system layouts through to installation.

Worcester is dedicated to providing energy efficient gas- and oil-fired condensing boilers, as well as an extensive range of renewable technologies. All of our products have been developed and introduced with the aim of helping the UK to achieve the Government's efficiency targets.



**BOSCH**  
Invented for life



The reception and main entrance at our Worcester headquarters

*“At Worcester we recognise the vital role you play in the specification and installation of energy efficient appliances in homes across the UK. We will continue to invest in our products, people, facilities and added value services to ensure you have everything you need to deliver only the best solutions to your customers’ requirements.”*

Carl Arntzen,  
Managing Director,  
Bosch Thermotechnology Ltd.

## Contents

	<b>Page</b>
Worcester Greenskies solar thermal panels	4
About solar in the UK	5
Types of solar thermal technology	6
Introduction to the Greenskies solar thermal family	7
Why choose Worcester solar?	8
Improvements to the Greenskies solar range	9
Greenskies solar thermal accessories	10 - 11
Renewable Heat Incentive (RHI) Scheme	12 - 13
ErP easy as ABC	14 - 15
Greenskies solar thermal product range at a glance	16 - 17
Introduction to Greenskies Solar-Lifestyle	18
Greenskies Solar-Lifestyle – installation instructions, pipework connections and kits	19 - 35
Introduction to Greenskies Solar-Lito	36
Greenskies Solar-Lito – installation instructions, pipework connections and kits	37 - 47
The Greenstore solar compatible unvented cylinder series	48 - 49
Greenskies plumbing considerations	50
Homeowner FAQs	51
Training	52 - 54
After-sales	55



## Worcester Greenskies solar thermal panels

As a part of the Bosch Group, Worcester is committed to environmental protection. Product development is prioritised in the interests of peoples' safety, the economical use of resources and environmental sustainability.

With this in mind, Worcester is proud to offer the Greenskies range of solar thermal panels, which use a sustainable energy source to provide efficient heating comfort.

Worcester Greenskies solar panels harness the heat from the sun in both direct and diffused sunlight. This heat radiation is absorbed by a glycol mix which is within the pipes and plumbing of the solar panels. The heated glycol is pumped through the solar system to the hot water cylinder which stores and distributes the hot water for the property.

The Greenskies range of panels have been specifically designed to complement existing home heating systems which have either a gas- or oil-fired boiler. If the home currently has a hot water cylinder it will need to be replaced with a twin-coiled version. If there is currently no hot water cylinder, a twin-coiled cylinder will also need to be installed. The addition of a cylinder with 2 heat exchanger coils will allow the solar thermal panel to provide the majority of hot water, whilst retaining the gas or oil boiler as a back-up heat source. For optimum efficiency and for ease of installation, we highly recommend a Worcester Greenstore solar compatible unvented cylinder be installed (see page 48 for details).

A typical well-sized solar thermal system should provide around 50-70% of the domestic hot water requirements of the home, representing a considerable saving on hot water heating costs. Further energy savings can be achieved by coupling a Greenskies system with a Greenstar high efficiency gas or oil boiler.

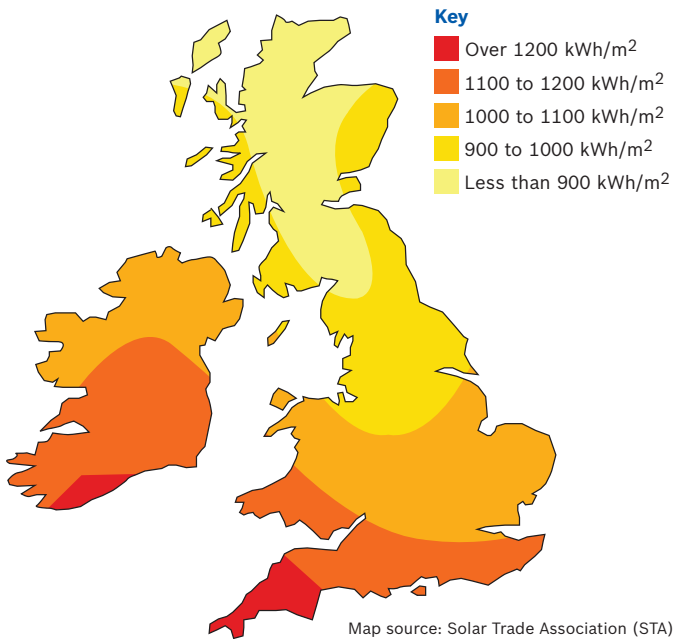

A common question about solar in the UK focuses on whether there is enough sunshine available to make solar thermal worthwhile. This is especially the case as the usual idea of British weather is one of cloudy skies and intermittent sunshine. However, contrary to popular belief, the amount of solar radiation received by the UK is suitable for highly efficient solar water heating, with the UK receiving 65% of the solar radiation that is received in the south of Spain. This is due in part, to the high levels of diffused radiation that the UK gains through clouds, which accounts for 60% of the total absorbed radiation.

Worcester's solar panels have been specifically developed with these typical weather types in mind, allowing them to make the most of both the direct (40%) and indirect (60%) sunlight throughout the year.

Summer will obviously provide the largest amount of radiation and direct hot water supply, but a Worcester Greenskies system will still provide a substantial contribution throughout the year. As an indication, a typical well-sized installation will provide the following proportion of the household domestic hot water requirement.

% of requirement fulfilled by solar	
Season	%
Summer	80 - 90%
Spring & Autumn	40 - 50%
Winter	20 - 30%

The table highlights how solar thermal hot water can translate to over half of the typical annual domestic hot water requirement. Indeed, a Worcester Greenskies system offers a viable supplement to existing domestic water heating and an excellent opportunity to reduce fuel bills wherever you are in the UK.

## How do solar water heating systems work?

Solar water heating systems use solar panels (called collectors) to collect the heat from the sun which is then used to heat up the water stored in a hot water cylinder. A boiler is then used, when required, to further heat the water to the desired temperature.

The panels are mounted on a surface which is selected for its exposure to sunlight. These are usually connected, via pipe work, to the lower coil of a twin-coil solar cylinder.

Worcester Greenskies solar panels form part of a system which remains separate from the boiler heating system.

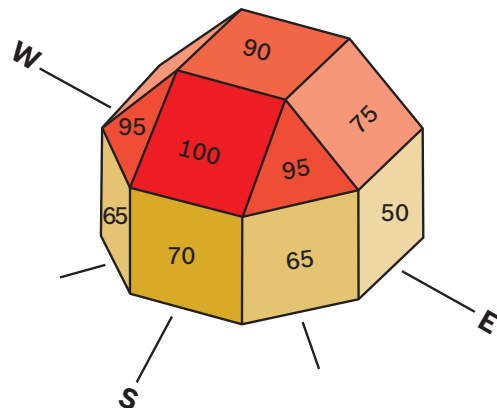

## Panel orientation

Where possible we recommend that solar panels are positioned in a south facing direction, with a vertical angle between 30 and 45°. The diagram above illustrates the best siting for a solar panel, with 100° showing the optimum position. It also highlights that it is possible to enjoy solar water heating with an east or west facing panel arrangement.

# Types of solar thermal technology

Worcester offers two types of flat plate collectors. They are equally suitable for domestic hot water creation, offering unique advantages and features which allow both customer and location specific needs to be met.

## Absorber plates

Worcester flat plate collectors utilise a PVD Aluminium full sheet absorber plate, which is ultrasonically welded to a copper pipe which collects the solar radiation. They also feature some of the best insulation on the market for flat plate collectors, with the Lifestyle in particular delivering an exceptional low loss performance.

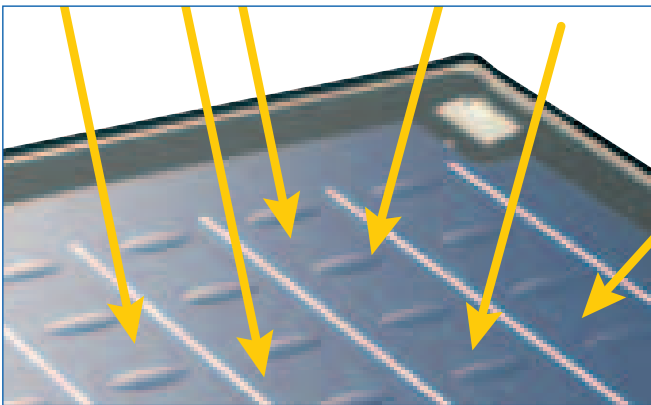

## Key factors to consider when choosing solar thermal technology

There are two key factors that affect the performance of solar thermal panels. These are the absorption efficiency of the solar collector, which is displayed technically as the  $\eta_0$ , and the ability of the solar panel to retain the heat in the collector, which is identified as the  $a_1$ .

The relationship between the  $\eta_0$  (energy gained) and  $a_1$  (energy lost) directly affects the collector performance, and is used by SAP when assessing a property's compliance with Building Regulations.

### $\eta_0$

The  $\eta_0$  represents the power output ratio at 1,000W per  $m^2$ . It indicates the start up efficiency and the percentage of energy that can be absorbed into the system when the solar fluid temperature is equal to the outside temperature. It should be noted however that this value is theoretical, since it applies to a very short period when the solar collector system is run up (e.g. immediately after being installed or in the morning when the sun comes up). In terms of performance, the higher the  $\eta_0$  the better, with a flat plate's large absorber being able to achieve a higher  $\eta_0$  than evacuated tubes.

### $a_1$

Every collector type has a specific heat throughput coefficient known as the  $a_1$ . The  $a_1$  value indicates the solar energy lost by the panel, which is directly affected by the insulation properties of the collector. This is vitally important, as retaining solar energy is key in allowing the glycol-fed system to absorb the heat from the collector before the heat is lost back into the atmosphere.

This chart highlights the power output potential of the Greenskies series when the temperature difference between the outside air and the heat transfer fluid in the collector ( $\Delta T$ ) increases. Useful heat is lost from any collector by conduction, convection and radiation, and this chart indicates how efficient the collectors are at retaining heat as they get hotter compared to the temperature outside.

## Greenskies performance

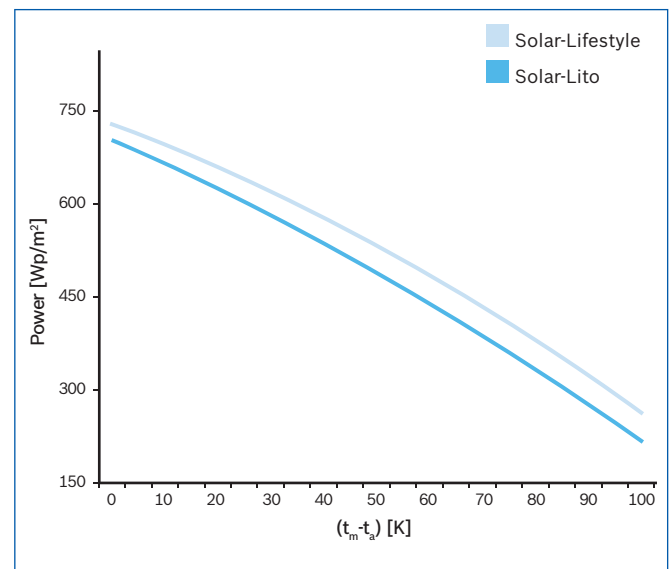

Power curves per  $m^2$  gross area (for  $G=1,000$  W/ $m^2$ )

# Introduction to the Greenskies solar thermal family

## Greenskies Solar-Lifestyle

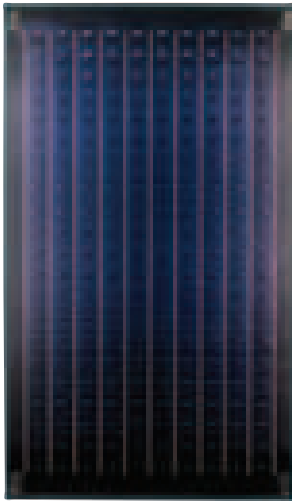

The name, as it suggests, stands for a product which fits in with all of the lifestyle requirements of the homeowner. The Solar-Lifestyle collector boasts a modern, visually stunning one-piece collector design.

This collector is highly versatile as it can be installed in-roof, on-roof, and as a flat-roof or façade. It is also available in a portrait and landscape format. It provides a high level of efficiency and is the optimum choice for most installations.

The Greenskies Solar-Lifestyle collectors feature a whole range of Installer's Choice Design (ICD) accessories which make installation easier. These include a green collector indicator on the centre rail connection pieces and security angled side brackets for easier insertion of tools.

### **Best applications:**

High performance all-rounder, visually pleasing with in-roof capabilities

## Greenskies Solar-Lito



### **Greenskies Solar-Lito**

The Lito collector offers the homeowner affordable solar hot water comfort, whilst also allowing flexible solutions for the installer.

Like the Lifestyle, the Greenskies Solar-Lito collectors also feature an attractive aluminium one-piece construction. This makes the collector lightweight, weighing in at a class-leading 30kg.

### **Best applications:**

Affordable on-roof hot water solutions

## Why choose Worcester solar?

Given the competitive nature of the heating industry, Worcester know that many installers have an important decision to make when choosing the best product for their customers. Many installers are loyal to the Worcester brand and recognise the importance of the technical support and training we offer.

However, what is sometimes not seen is the work that goes on behind the scenes in our quality and engineering departments to make sure you and your customers benefit from the best in high efficiency boilers and renewable technologies.

Every Worcester Greenskies solar collector is put through its paces and the most extreme conditions are re-created to ensure they are robust enough to stand up to the highest of demands and harshest of environments.

Multiple structural and temperature tests are undertaken when analysing Greenskies collectors. For example, sea salt resistance tests are undertaken and to assess impact resistance, ice balls weighing 7.53g, with a diameter of 25mm, are fired onto test collectors at 51.4mph to check panel integrity.



## Did you know?

Worcester offers its own solar thermal sizing service. The design team produce technical drawings and provide specification advice for a range of solar thermal customers. All our team are accredited SAP assessors and hold a IDHEE Domestic Heating Certificate. The team offers solar thermal system sizing which will calculate:

- Recommended cylinder size
- Recommended number of panels
- Annual solar input
- Annual cost saving and RHI benefit
- Annual CO<sub>2</sub> saving



Also to assist with calculating your solar thermal requirements and performance, the team have developed a free solar thermal calculator.

Solar Thermal Calculator:

[www.worcester-bosch.co.uk/st](http://www.worcester-bosch.co.uk/st)

- Did you know that solar thermal is the easiest renewable technology to integrate with an existing gas or oil boiler? Please see the Worcester Gas and Oil Technical Specification brochures for details of further Worcester products.
- Did you know that you can find roofing specialists by contacting the National Federation of Roofing Contractors (NFRC) which is the UK's largest roofing trade association? They have a list of Solar roofing specialists on their website who may wish to work with heating engineers to install solar thermal.
- With over 100 people in the quality control team on-site, Worcester has more quality control engineers than sales representatives.
- Thanks to being part of the global Bosch Group, Worcester has access to the worldwide resources of Bosch, including a corporate research department and access to Bosch automotive processes.



# Improvements to the Greenskies solar range

## Installer's Choice Design

In addition to our own extensive testing and research, we also listen and respond to installers as part of our continuous product development programme, using your suggestions to help improve our products.

Based on your recommendations we have introduced something we call Installer's Choice Design (ICD). ICD represents a wide range of installer focused improvements which save time and money through a quicker and easier installation. Examples include the new versatile ICD roof hook, which has an increased positioning flexibility of 108mm and the new indicator bracket, which improves safety by clearly indicating if the collectors have been correctly secured together.

## Greenskies Solar-Lito – improved collector surface

The Lito has been improved by the addition of a full PVD aluminium sheet absorber plate which like the Lifestyle, is ultrasonically welded to a harp copper pipe absorber to collect the solar radiation. This has affected the Solar-Lito collectors by decreasing the  $a_1$  heat loss, whilst also increasing the overall efficiency and output.

## Greenskies solar thermal selector

Based on customer feedback and to assist with the specification of your solar system, Worcester has developed a complete solar thermal selector for our range of Greenskies panels. This intuitive mobile and PC enabled site, allows you to select every component you will need for your Worcester solar system.

It also provides advice on annual savings and potential RHI funding. The Greenskies solar thermal selector can be accessed via most smart phones via the QR link below, or by visiting [www.worcester-bosch.co.uk/solar-selector](http://www.worcester-bosch.co.uk/solar-selector)

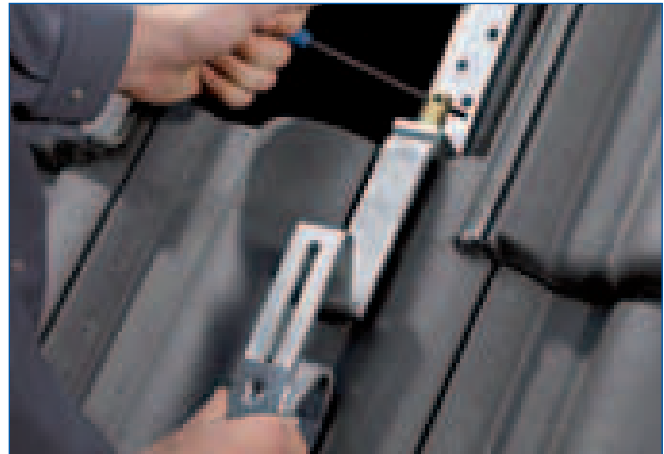

ICD is exclusive to the Greenskies Solar-Lifestyle collectors.

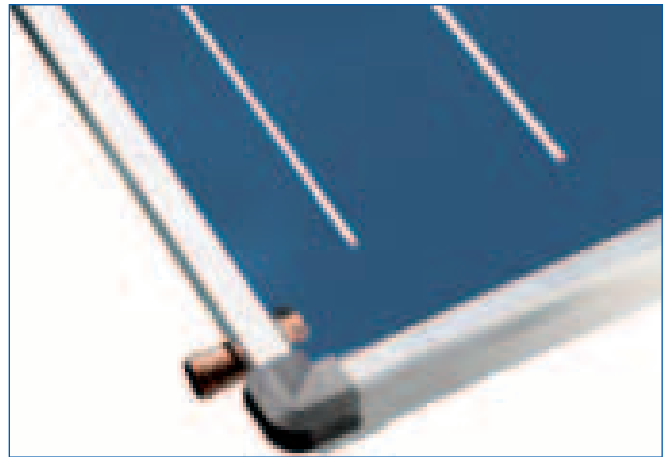

# Greenskies solar thermal controls

There are 2 Worcester solar controllers available to complement both Greenskies flat plate collectors.



## **TDS100-2**

The standard controller is the TDS100-2. It features 3 NTC sensor inlets and a clear LCD graphic display and menu. The controller can also control the modulation of the low energy pump station in order to maximise energy savings.

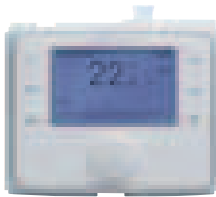

## **CS200 plus MS200**

The Worcester CS200 Solar Controller, used in conjunction with the MS200 Intelligent Solar Module allows for the control of pumps and sensors within advanced solar thermal systems. The CS200 does not control other elements of a heating system.

The MS200 Intelligent Solar Module, for use in conjunction with a Worcester CS200, allows for the control of pumps and sensors within advanced solar thermal systems. The MS200 can control 2 pumps for multiple collector fields, for example an East/West split. The module will also receive input via sensors recording solar collector and hot water cylinder temperatures. The MS200 can also be used within swimming pool installations.

## Boiler control integration

There are also control options available which will integrate the solar controller with a Worcester intelligent boiler controller. An ISM1 module is required in conjunction with either an FR110 or FW100 controller.



## **ISM1**

A special interface that enables the hot water system to utilise the heat from the panels when the sun is shining, whilst ensuring the boiler provides any additional heat when required. This is compatible with Greenstar system boilers with an integral diverter valve. The ISM1 must be used with the FR110 or FW100, removing the need for a specific solar controller.



## **FR110 & FW100**

Part of the Worcester FX boiler control series. Either of these boiler controls can be used with the ISM1 to optimise the combination of the boiler and solar. Please see the Worcester Controls Series Technical and Specification brochure for more information. Use of an FR110 or FW100 negates the need for a TDS100 or TDS300 control.

## Glycol variants



Tyfoco© L

Our Greenskies range utilises Tyfoco© glycol is specifically formulated to restrict corrosion, protect against high temperatures and to offer excellent freeze protection. The glycol comes pre-mixed to aid commissioning of the system and to ensure maximum performance.

## Pump stations

There are 2 pump stations to choose from – the AGS10E-2 single line pump and the AGS10-2 twin line pump. Both pump stations are compatible with flat plate panels.

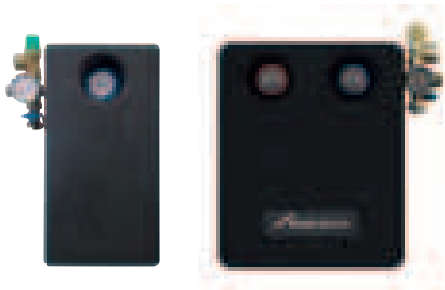

### AGS10E-2 single-line and AGS10-2 twin-line pump stations

Both pump stations are similar although the twin-line AGS10-2 has the advantage of an integrated air separator to aid commissioning and maintenance.

Both of the pump stations can be modulated when combined with either the TDS100-2 or our CS200 controller and MS200 module. They feature a 6bar pressure relief valve and 15/22mm connections. The two pump stations can also be installed in combination for an East/West split\*. The AGS10E-2 and AGS10-2 can accommodate up to 10 flat plate collectors and 60 tubes.

*\*In conjunction with the CS200 controller and MS200 module.*

# The Greenstore solar compatible unvented cylinder series



### Greenstore solar compatible unvented duplex stainless steel cylinders

Worcester's Greenstore solar compatible, stainless steel hot water storage cylinders have been specifically designed for use with solar heating installations. They offer outstanding efficiency, ease of installation and full compliance with current and anticipated legislation.

Developed and manufactured by Bosch Thermotechnology Ltd, the Greenstore solar compatible unvented series comprises five models ranging from the TC-150 to the TC-300. All models feature high levels of insulation and dedicated solar volumes in compliance with current Building Regulations, SAP 2012 and the Microgeneration Certification Scheme (MCS). More information on the Greenstore range is available on pages 48-49.



# Renewable Heat Incentive (RHI) Scheme for Domestic Properties

## Overview

The Renewable Heat Incentive (RHI) scheme for industry, business and the public sector was introduced by the Government in November 2011 as part of its commitment to reduce the country's carbon emissions by 20% by 2020.

The scheme is now extended to domestic users who are able to generate and use renewable energy to heat their properties.

This provides installers with an opportunity to inform homeowners of the RHI scheme and the money they can expect to receive by switching, even in part, to approved renewable energy sources instead of using fossil fuels.

## Who is eligible?

The domestic RHI scheme applies to both off-grid and on-grid properties in England, Scotland and Wales.

The scheme covers single domestic dwellings and is open to owner-occupiers, private landlords, registered providers of social housing, third party owners of heating systems and self-builders.

The scheme is open to all of the previous who have had applicable renewable technologies installed since 15th July 2009. However, applications will be dealt with on a phased basis over a period of time by the scheme administrator, Ofgem.

## Who isn't eligible?

Housing developers are excluded from the scheme although it is possible that they could be eligible under the existing non-domestic scheme.

# Tariffs

When discussing the RHI scheme with your customers, the first question you'll probably be asked is "how much will I get and for how long?"

Tariffs have been calculated by The Department of Energy and Climate Change (DECC) and will change annually in-line with the previous year's Retail Price Index.

All payments are made directly to the homeowner retrospectively every quarter over a period of seven years.

The tariffs are per kilowatt hour of renewable energy produced by each of the following technologies:

Renewable product	Price per kWh
LECP Ground Source Heat Pumps	19.1p per kWh
Solar thermal	19.51p per kWh

Heat pumps and solar tariffs can be jointly claimed providing they are in the same property.

# How will the payments be calculated?

## Air and ground source heat pumps

The amount of renewable energy qualifying for payment is based on a deemed estimate of the heat demand from the property's Energy Performance Certificate (EPC). This is combined with an estimate of a heat pump's efficiency minus the energy required to run it.

## Solar thermal

The amount of renewable energy qualifying for payment is based on a deemed estimate of the solar thermal performance completed as part of a Microgeneration Certification Scheme (MCS) installation. The Worcester solar selector can calculate this amount for you.

# What criteria are required to apply for the scheme?

## Training

All installations must be carried out by an MCS approved installer and meet the relevant standards for each technology. Worcester runs MCS and individual renewables product courses at each of its training academies. For further information visit [www.worcester-bosch.co.uk/training](http://www.worcester-bosch.co.uk/training) or call **0330 123 0166**.

## Energy Performance Certificates (EPC)

In situations where the loft and cavity wall insulation have not been installed, the property's EPC will need to be updated when the work has been carried out. In properties where installation is not feasible, an EPC will also be required as proof.

The only exception is for self-builders whose properties will meet Building Regulation requirements for energy efficiency and will therefore already qualify for the scheme. They will, however, require an EPC to enable Ofgem to calculate payments.



**Please note: Renewable Heat Premium Payments or other public funds previously claimed for a system will be deducted from RHI payments.**

# ErP easy as ABC

## What is ErP?

The ErP Directive, which is a new regulation set by the European Union, is designed to drive improvements in the efficiency and performance of heating and hot water products. Its purpose is to ensure that end users are aware of the level of energy efficiency inherent within their appliances. As such, the Directive will help improve the overall efficiency of the housing stock, while enabling homeowners to reduce their energy bills. The ErP regulations cover boilers, combination boilers, heat pumps and systems incorporating solar thermal technology.

## What is Energy Labelling?

The Energy Labelling involves a label which we are familiar with today on washing machines and televisions at the point of sale. The Energy Labelling regulations introduce Europe-wide energy labelling requirements for solar thermal systems that are installed in conjunction with boilers and heat pumps under 70kW, alongside hot water cylinders under 500 litres.

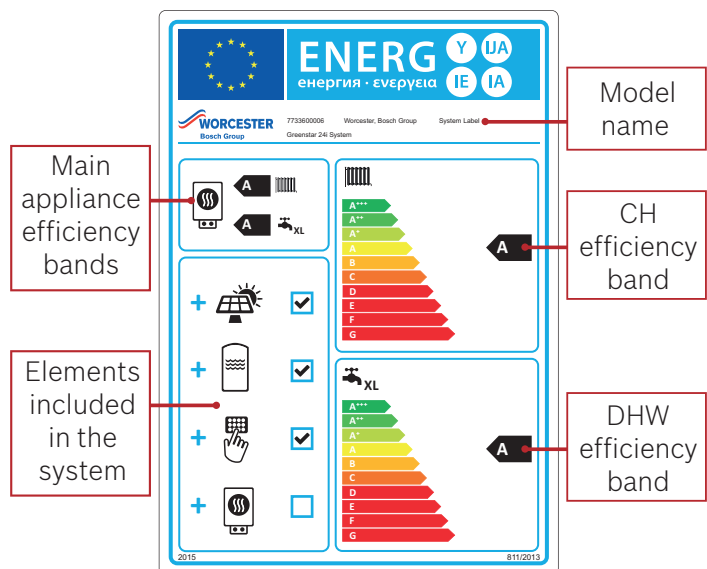
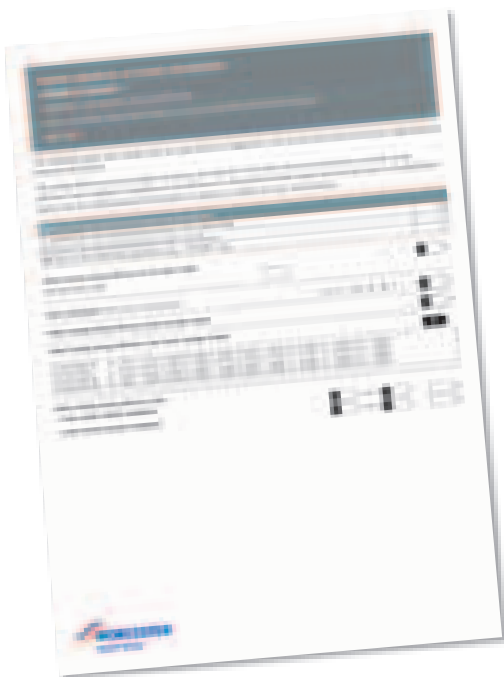
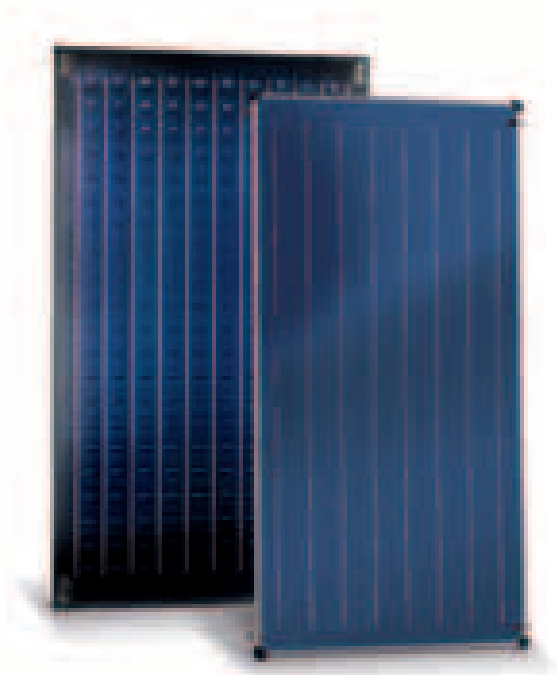

### What about systems that contain solar thermal products?

In these circumstances, there is a responsibility to provide a package label when combining solar thermal with a heating appliance under 70kW and a solar cylinder 500 litres or smaller (for example, a Greenstar system boiler in conjunction with a Greenstore solar twin coil cylinder).

The person who puts that package together will need to produce a package document known as a fiche (data table) and label that provides the combined energy efficiency rating rather than ratings of each individual component.

For example, this could be the merchant's responsibility if they supply a complete package under one part number or the installer if the items are bought individually under separate part numbers.

In either circumstance, Worcester will provide an online tool that makes calculating the overall package efficiency of a Worcester system effortless.



---

## ErP easy as ABC with Worcester

The Energy Labelling obligation under the Energy Related Products (ErP) Directive comes into force on the 26th September 2015. Worcester will have a number of measures in place to support you including:

- ✔ An **online tool** which creates product and heating system labels
- ✔ ErP will be covered in all **Worcester training courses**
- ✔ **ErP experts** – our technical and customer support teams can answer all your questions.













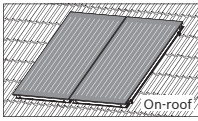
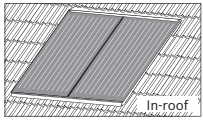
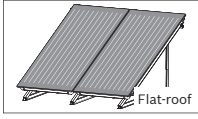



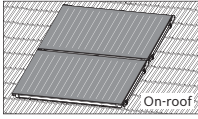
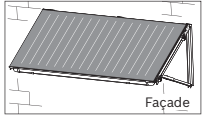
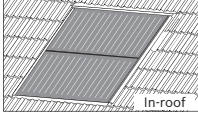
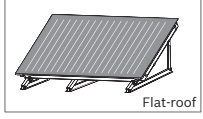

ErP Technical Support: **0330 123 3641**

Email: **[ErP-advice@uk.bosch.com](mailto:ErP-advice@uk.bosch.com)**

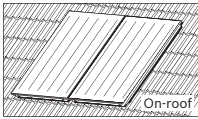
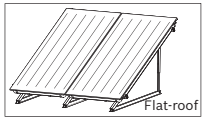

# Greenskies solar thermal product range at a glance

These pages highlight the variations, roof types, dimensions and performance data for the Greenskies range. Key customer requirements such as available roof space, roof orientation, tile type and cylinder capacity as well as the information below should help you to choose the most suitable Greenskies collector type for your installation.

Collector	Variant options		Roof
	Variant	Roof orientation	Tile type
<b>Solar-Lifestyle</b>   See page 18-35 for details	<b>Solar-Lifestyle Portrait</b> 	  	 Std pantile concrete  Slate/shingle  Metal corrugated  Raised concrete (in-roof)*
	<b>Solar-Lifestyle Landscape</b> 	   	 Std pantile concrete  Slate/shingle  Metal corrugated  Raised concrete (in-roof)*
<b>Solar-Lito</b>  See page 36-47 for details	<b>Solar-Lito</b> 	 	 Std pantile concrete  Slate/shingle  Metal corrugated

\*Raised concrete flashing should be used when the distance between the top edge of the roof batten and the highest protrusion of the tile is above 70mm (up to 140mm max).



**Please note: These pages are intended to serve as a guide only as all solar installations are unique. The installation guides supplied with the product should always be referred to.**

	Dimensions (mm)			Collector area			Performance data			Collector quantity for cylinder variant*					Incident Angle Modifier (IAM)
	Height	Width	Depth	Gross	Aperture	Absorber	Zero loss $\eta_0$	a1 heat loss $W/m^2k$	a2 heat loss $W/m^2k^2$	150l	180l	210l	250l	300l	
2017	1175	87	2.37m <sup>2</sup>	2.25m <sup>2</sup>	2.18m <sup>2</sup>	76.6%	3.216 $W/m^2k$	0.015 $W/m^2k^2$	1	1	2	2	3	0.92	
1175	2017	87	2.37m <sup>2</sup>	2.25m <sup>2</sup>	2.18m <sup>2</sup>	76.6%	3.871 $W/m^2k$	0.012 $W/m^2k^2$	1	1	2	2	3	0.92	
2026	1032	67	2.09m <sup>2</sup>	1.94m <sup>2</sup>	1.92m <sup>2</sup>	76.1%	4.083 $W/m^2k$	0.012 $W/m^2k^2$	1	1	2	2	3	0.94	

\*Approximate, Worcester always recommends a correct sizing survey is carried out prior to installation

# Greenskies Solar-Lifestyle

The Solar-Lifestyle is Worcester’s most efficient and versatile flat plate collector. It boasts not only an industry-leading low  $a_1$  heat loss of up to 3.871, but it also achieves a high  $\eta_0$  start up performance, making the Solar-Lifestyle a competitive choice when being assessed in SAP.

The Solar-Lifestyle collector is a modern, visually stunning, one-piece panel design. It is lightweight and is designed with an easy installation in mind. The Solar-Lifestyle features benefits such as built-in carry handles and a wide range of Installer’s Choice Design (ICD) accessories. These include a green indicator button on the centre rail connection pieces for added security and angled side brackets for easier insertion of tools.

The Solar-Lifestyle is fully tested and Key mark certified. It is therefore eligible for available paybacks and incentives which are recognised by the MCS scheme.

Collector type	Solar-Lifestyle	Solar-Lifestyle
Orientation	Portrait	Landscape
Dimensions	1175x2017x87mm	2017x1175x87mm
Gross collector area	2.37m <sup>2</sup>	2.37m <sup>2</sup>
Aperture area	2.25m <sup>2</sup>	2.25m <sup>2</sup>
Absorber area	2.18m <sup>2</sup>	2.18m <sup>2</sup>
Absorber volume	0.94 litres	1.35 litres
Weight empty	40kg	41kg
Absorption	95 ± 2%	95 ± 2%
Emissions	5 ± 2%	5 ± 2%
$\eta_0$	76.6%	76.6%
$a_1$	3.216 W/m <sup>2</sup> k	3.871 W/m <sup>2</sup> k
$a_2$	0.015 W/m <sup>2</sup> k <sup>2</sup>	0.012 W/m <sup>2</sup> k <sup>2</sup>
ErP collector efficiency	61%	60%
1,000 W/m <sup>2</sup>		
$\Delta T = 0K$	1,725 W/m <sup>2</sup>	1,735 W/m <sup>2</sup>
$\Delta T = 30K$	1,478 W/m <sup>2</sup>	1,450 W/m <sup>2</sup>
$\Delta T = 50K$	1,279 W/m <sup>2</sup>	1,233 W/m <sup>2</sup>
Stagnation temperature tstg.	199.3°C	199.3°C
Max. operation pressure pmax	6 bar	6 bar
Nominal flow rate [l/h]	50 litres/hour	50 litres/hour
Incident Angle Modifier (50T)	0.92	0.92
MCS certification number	011-7S 1610F	011-7S 1720F
Part number	8 718 530 950	8 718 530 951

*W = power (instant power)*

## Greenskies Solar-Lifestyle collector close up

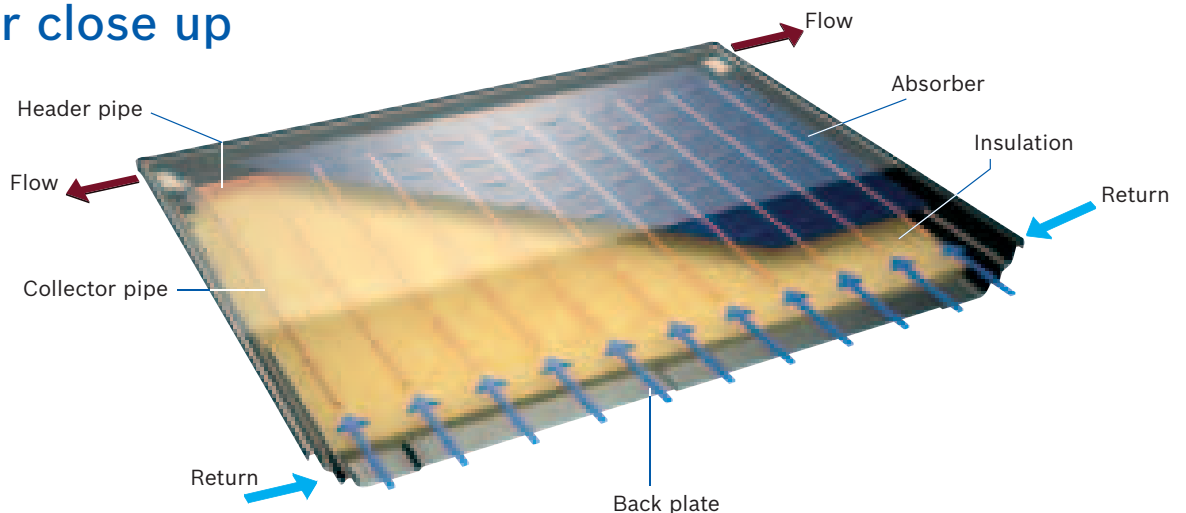

## Installation options

Our high performance Solar-Lifestyle flat plate collectors offer the widest range of installation options for both the consumer and the installer, with all of the mounting options being available in either portrait or landscape arrangements. These include installations on-roof – with standard concrete pantile, slate and corrugated metal roof surfaces. Slate tiles can be different thicknesses, we offer a range of flashing kits to suit please see page 32. In-roof – to provide a flush and hidden effect and flat-roof – which can be angled between 45° and 60° and secured via either a loading tray set or a conventional fixing to the roof. Finally, the Solar-Lifestyle can be installed as a façade which can also be angled between 45° and 60°.

The Solar-Lifestyle can be installed in a first and second fix as the roof kits and hydraulic plumb kits are available in two separate packs. This allows a specialist roofer to fit the roof mounting kit prior to the commissioning of the system if required. It also ensures only the necessary kit is on site when needed.

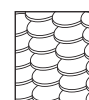

Slate/shingle



Standard concrete pantile



Raised concrete (in-roof\*)



Metal corrugated

*\*Raised concrete flashing should be used when the distance between the top edge of the roof batten and the highest protrusion of the tile is above 70mm (up to 140mm max).*

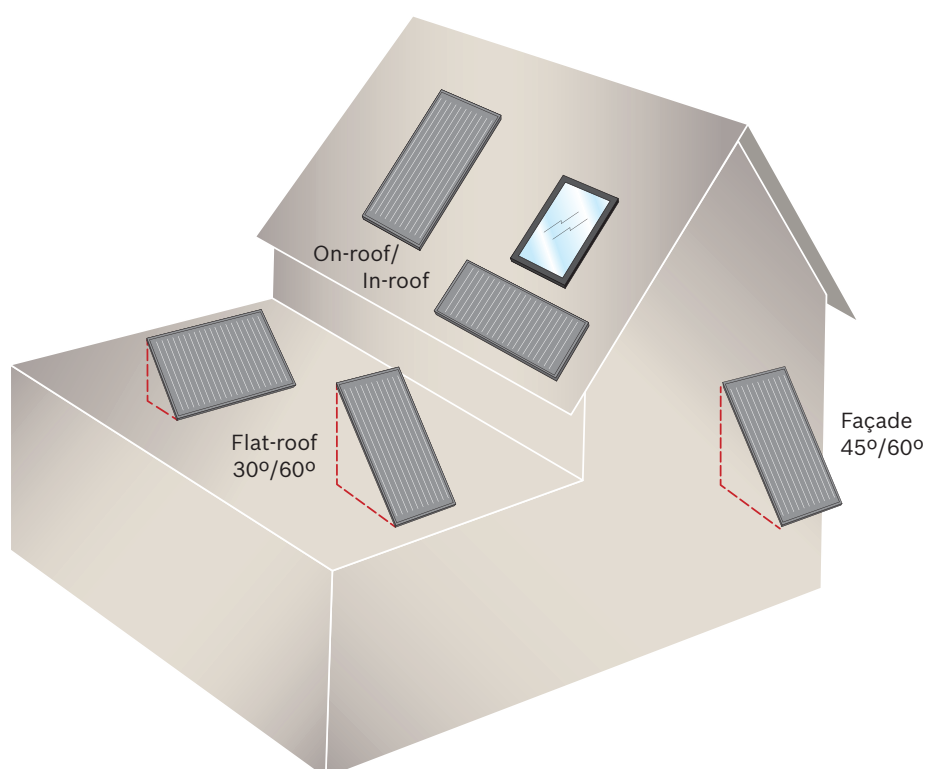

# Greenskies Solar-Lifestyle on-roof installation guide

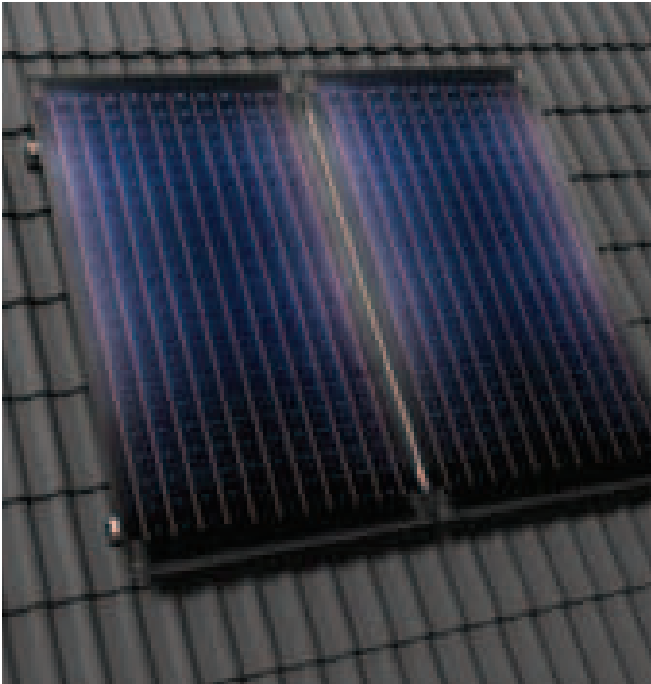

## Collector dimensions and clearances

Please observe the following minimum space requirements.

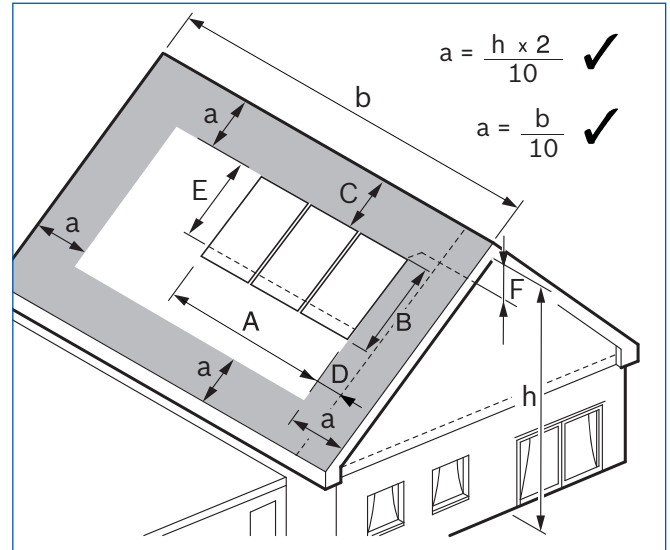

Number of collectors*	Vertical orientation		Horizontal orientation	
	Dimension A	Dimension B	Dimension A	Dimension B
1	1.18m	2.02m	2.02m	1.18m
2	2.38m	2.02m	4.06m	1.18m
3	3.58m	2.02m	6.11m	1.18m
4	4.78m	2.02m	8.15m	1.18m
5	5.98m	2.02m	10.19m	1.18m
6	7.18m	2.02m	12.23m	1.18m
7	8.38m	2.02m	14.27m	1.18m
8	9.58m	2.02m	16.32m	1.18m
9	10.78m	2.02m	18.36m	1.18m
10	11.98m	2.02m	20.40m	1.18m

Space required for vertical and horizontal versions

### Dimension a

Either formula can be used. The lower value can be applied.

### Dimensions A and B

(See table left).

### Dimension C

At least 2 rows of tiles to ridge or chimney (or at least 0.5m if 3 rows of tiles are smaller than this distance).

### Dimension D

At least 0.5m for the flow on the right or left of the collector array.

### Dimension E

Equals 1.8m (horizontal version: 1.0m) and is the minimum clearance from the upper edge of the collector to the lower profile rail, which is installed first.

### Dimension F

If an air vent valve is required in the roof for air circulation, it must measure at least 0.4m.

## On-roof mounting kit

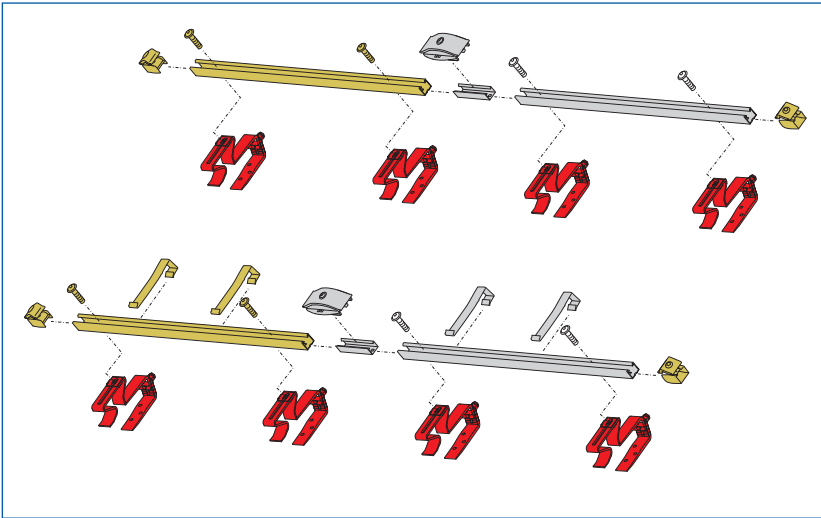

Key	
	Profile rail - 1st collector
	Single-sided collector clamp
	Additional profile rail
	Double-sided collector clamp
	Connector
	Roof hook, adjustable
	Anti-slip protector

## Greenskies Solar-Lifestyle portrait collectors

- Wind loads: up to 1.1kN/m<sup>2</sup> (~151km/h)
- Snow loads: up to 2.0kN/m<sup>2</sup>

- Wind loads: > 1.1kN/m<sup>2</sup> (~151km/h)
- Snow loads: > 2kN/m<sup>2</sup> - 3.1kN/m<sup>2</sup>

expandable up to 10 collectors →

Two additional roof connection included in 'snow load profile'

expandable up to 10 collectors →

## Greenskies Solar-Lifestyle landscape collectors

- Wind loads: up to 1.1kN/m<sup>2</sup> (~151km/h)
- Snow loads: 2.0kN/m<sup>2</sup>
- Lath distance < 420mm

expandable up to 10 collectors →

# Greenskies Solar-Lifestyle in-roof installation guide

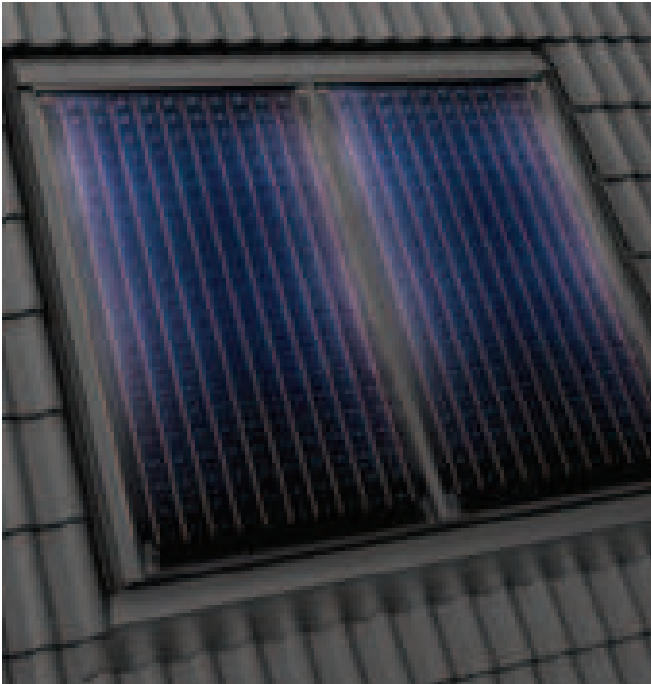

## Collector dimensions and clearances

Please observe the following minimum space requirements.

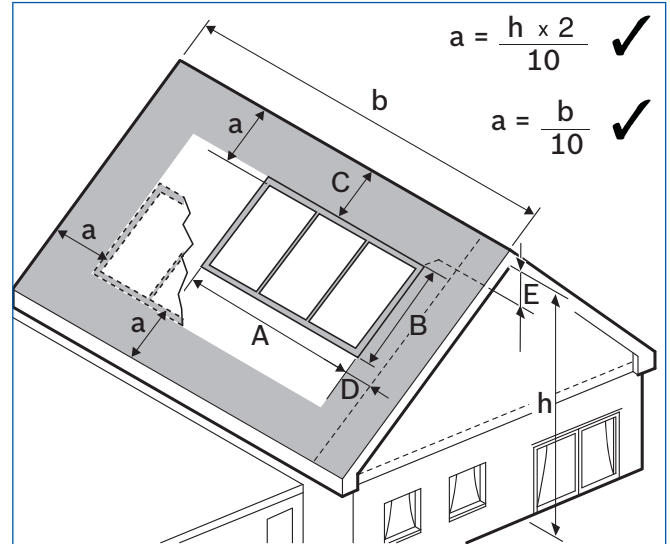

Dimension A (including flashing panels)				
Number of collectors	Roof tile/slate		Raised tile	
	Portrait	Landscape	Portrait	Landscape
1	1.54m	2.38m	1.61m	2.45m
2	2.74m	4.42m	2.81m	4.49m
3	3.94m	6.46m	4.01m	6.53m
4	5.14m	8.50m	5.21m	8.57m
5	6.34m	10.55m	6.41m	10.62m
6	7.54m	12.59m	7.61m	12.66m
7	8.74m	14.63m	8.81m	14.70m
8	9.94m	16.67m	10.01m	16.74m
9	11.14m	18.71m	11.21m	18.78m
10	12.34m	20.76m	12.41m	20.83m

Space required for vertical and horizontal versions

Dimension B (including flashing panels)						
Series	Roof tile		Raised tile		Slate	
	Portrait	Landscape	Portrait	Landscape	Portrait	Landscape
1, without lead flashing	2.59m	1.75m	2.86m	2.02m	2.62m	1.77m

### Dimension a

Either formula can be used. The lower value can be applied.

### Dimension A

Space requirement including collector (see table left).

### Dimension B

Space requirement including collector (see table left).

### Dimension C

At least 2 rows of tiles to ridge or chimney (or at least 0.5m if 3 rows of tiles are smaller than this distance).

### Dimension D

At least 0.5m for the flow on the right or left of the collector array.

### Dimension E

If an air vent valve is required in the roof for air circulation, it must measure at least 0.4m.

**Note: Allow for a clearance of at least 3 roof tiles between both collector arrays.**

## In-roof mounting kit

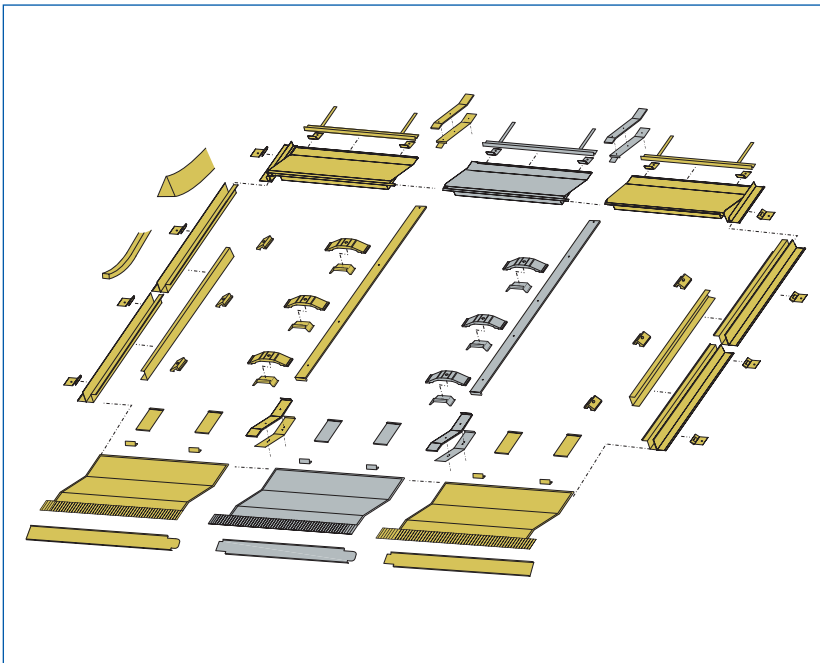

Key	
	Upper flashing panel, left
	Upper flashing panel, centre
	Upper flashing panel, right
	Lateral flashing panel, top left
	Lateral flashing panel, top right
	Lateral flashing panel, bottom
	Lateral support panel
	Lower flashing panel, right
	Lower flashing panel, centre
	Lower flashing panel, left
	Fascia, right
	Fascia, centre
	Fascia, left
	Retainer
	Joiner for lower flashing panel, bottom section
	Joiner for lower flashing panel, top section
	Anti-slip bracket
	Clamp, double-sided
	Spacer
	Middle cover strip
	Clamp, single-sided
	Mounting bracket
	Roof tile support
	Joiner for upper flashing panel, top section
	Joiner for upper flashing panel, bottom section

## Greenskies Solar-Lifestyle portrait/landscape collectors\*

- For snow loads up to 3.8kN/m<sup>2</sup> and 1.1kN/m<sup>2</sup> (~151km/h) wind

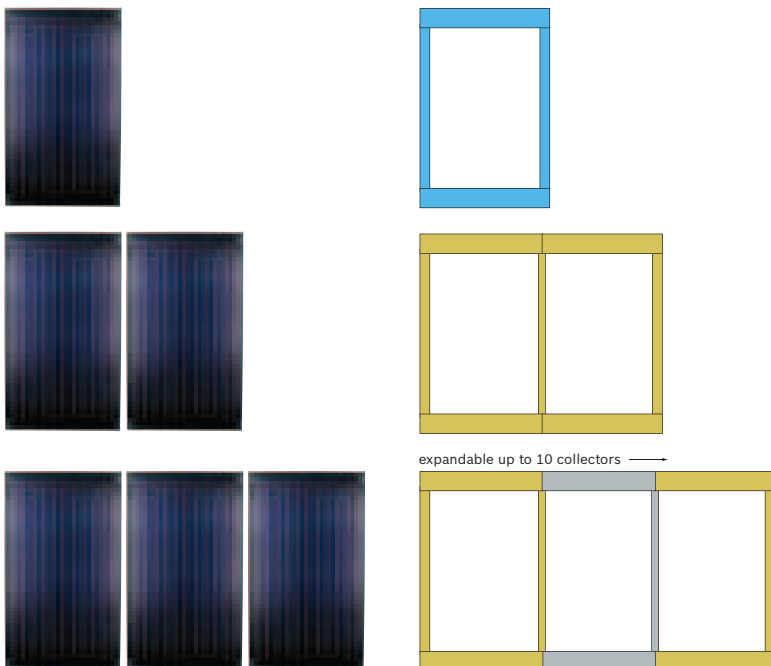

\*Suitable for standard pan tile roofs only. When installing on other roof types please check the part list at the rear of this brochure for alternative parts.

# Greenskies Solar-Lifestyle flat-roof installation guide



The minimum clearance X between the collectors results from the collectors' angle of incidence. Clearance between the rows of collectors at minimum solar altitude (on a flat-roof: 17°; on a wall: 61°).

## Shadow clearance

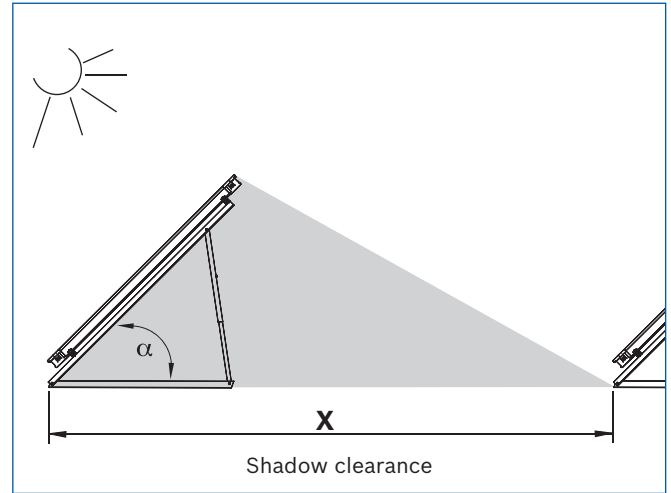

Determining the clearance between rows of collectors		
Angle of incidence $\alpha$	Clearance X – flat-roof	
	Portrait	Landscape
30°	5.05m	2.94m
35°	5.44m	3.17m
40°	5.79m	3.37m
45°	6.09m	3.55m
50°	6.35m	3.70m
55°	6.56m	3.82m
60°	6.72m	3.92m

## Greenskies Solar-Lifestyle flat-roof options

### Greenskies Solar-Lifestyle portrait collectors

**Flat support by conventional fitting or loading tray set**

- Wind speed  $\leq 151\text{km/h}$
- Snow loads  $\leq 2\text{kN/m}^2$

### Greenskies Solar-Lifestyle landscape collectors

**Flat support by conventional fitting or loading tray set**

- Wind speed  $\leq 151\text{km/h}$
- Snow loads  $> 2\text{kN/m}^2 - 3.8\text{kN/m}^2$



## Flat-roof mounting kit

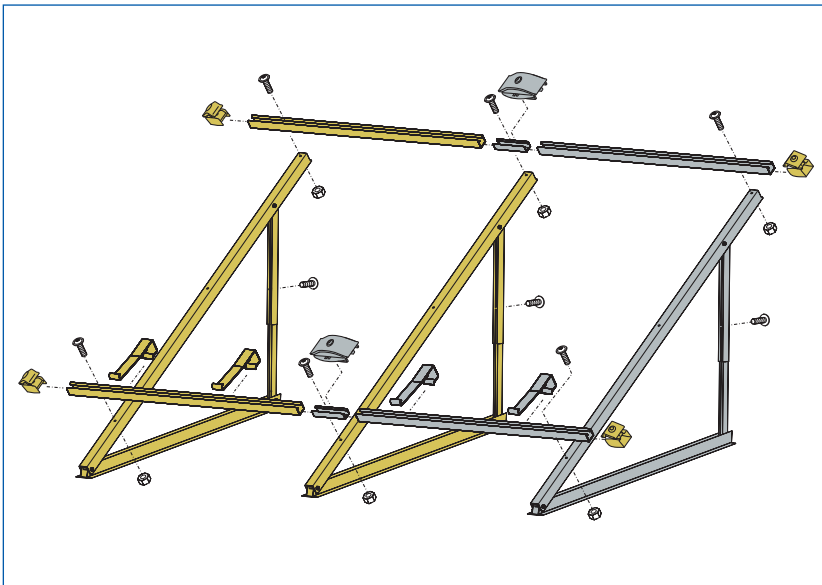

Key	
	Profile rail – 1st collector
	Collector brace
	Single-sided collector clamp
	Additional profile rail
	Additional collector brace
	Double-sided collector clamp
	Additional collector connector
	Anti-slip protector

### Fixed loading tray set or conventional fitting

The Worcester Greenskies flat-roof mounting kits can be secured to the roof in two ways. Firstly, a loading tray set can be attached to the mounting kits, which weighs down the collectors (see page 33) or secondly, they can be secured by a conventional fitting, directly attaching the collectors onto the roof surface.

### Greenskies Solar-Lifestyle portrait collectors

#### Using auxiliary rail for flat-roof support fixed by loading tray set



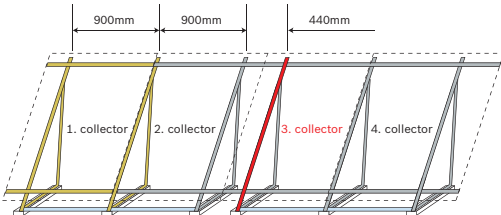

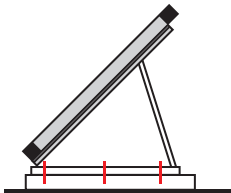

- Wind speed  $\leq 151\text{km/h}$
- Snow loads  $\leq 2\text{kN/m}^2$



### Greenskies Solar-Lifestyle landscape collectors

#### Using auxiliary rail for flat-roof support fixed by loading tray set

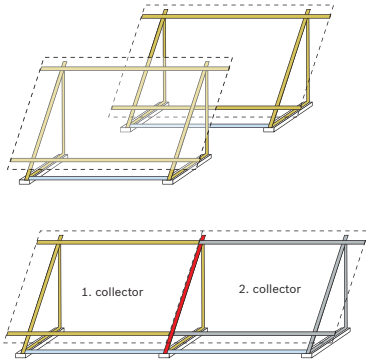

- Wind speed  $\leq 151\text{km/h}$
- Snow loads  $\leq 2\text{kN/m}^2 - 3.8\text{kN/m}^2$

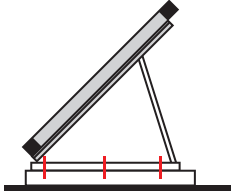

## Greenskies Solar-Lifestyle portrait collectors

### Using auxiliary rail for flat-roof support fixed by conventional set

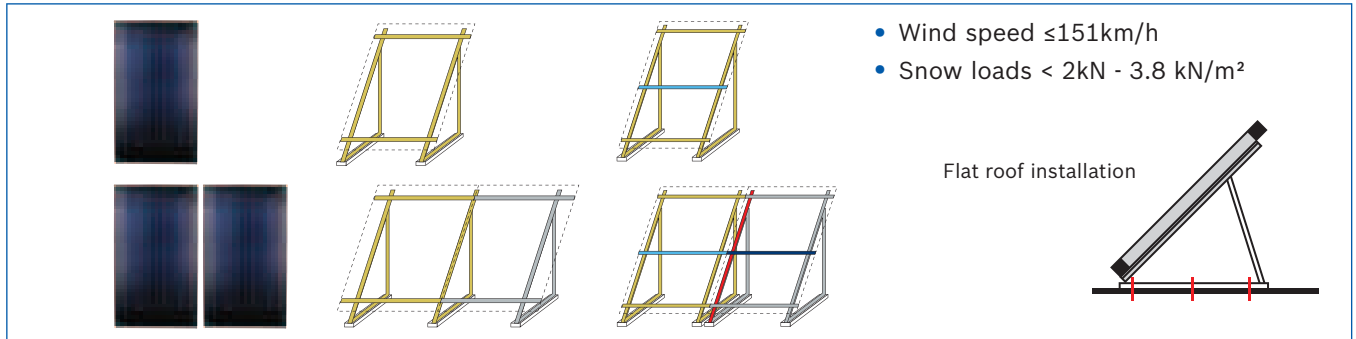

## Greenskies Solar-Lifestyle landscape collectors

### Using auxiliary rail for flat-roof support fixed by conventional set

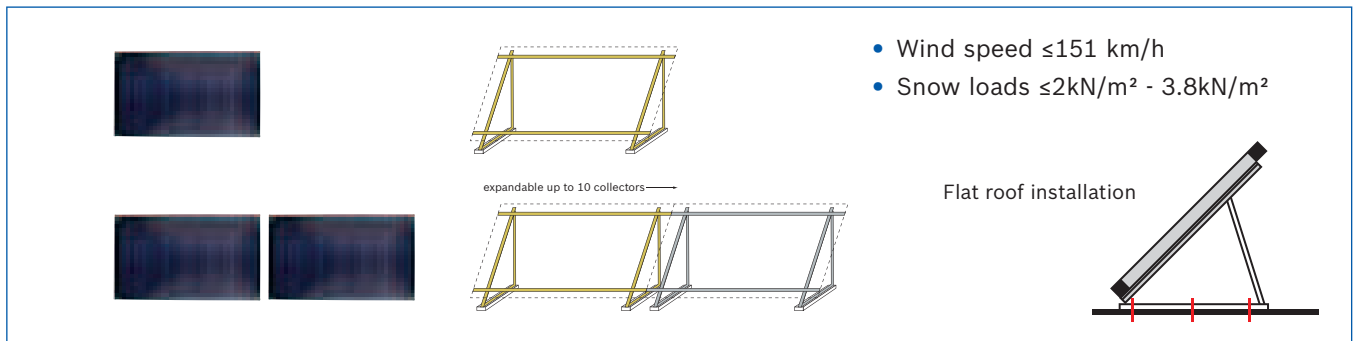

## Wind speed: fixing of flat-roof supports

It is important to check the maximum possible load of the roof. The table below applies to both portrait and landscape.

Corresponding wind speed	Fixing by loads (loading tray set)	Fixing by loads and additional cable	Fixing by customer (on external support)
102km/h	278kg/collector	186 kg/collector + cable with 2.0kN maximum traction	4 x screw M8/8.8
129km/h	481kg/collector	329 kg/collector + cable with 3.0kN maximum traction	4 x screw M8/8.8
151km/h	695kg/collector	486 kg/collector + cable with 4.0kN maximum traction	6 x screw M8/8.8

### Example of 5 and 10 collectors

- Wind speed  $\leq 151 \text{ km/h}$
- Snow loads  $\leq 2 \text{ kN/m}^2$



- Flat roof support basic set, vertical
- Flat roof support extension set, vertical
- Loading tray set
- Auxiliary rail flat roof support, horizontal, needed for collector row with 3rd, 6th or 9th collectors and at the end row  $\leq 3 \text{rd}$ , 6th or 9th collectors

# Greenskies Solar-Lifestyle façade installation guide



## Shadow clearance

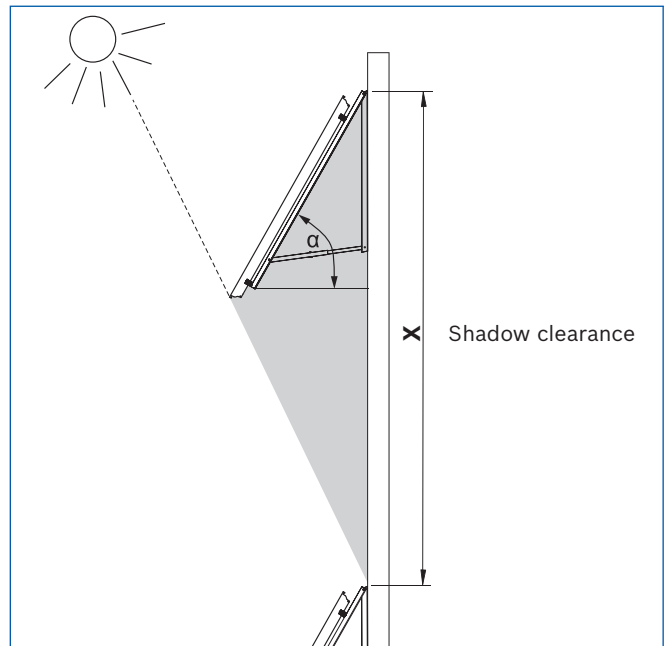

Determining the clearance between rows of collectors	
Angle of incidence $\alpha$	Clearance X - wall
	Landscape
30°	-
35°	-
40°	-
45°	2.33m
50°	2.26m
55°	2.18m
60°	2.08m

The minimum clearance X between the collectors results from the collectors' angle of incidence. Clearance between the rows of collectors at minimum solar altitude on a wall is 61°.

## Façade mounting combinations

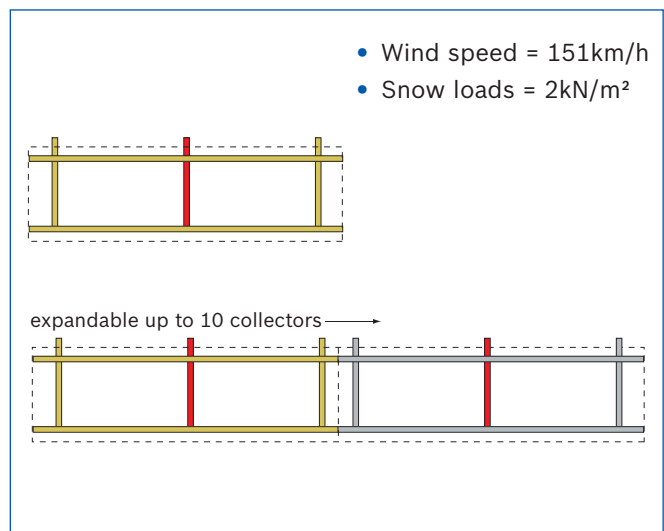
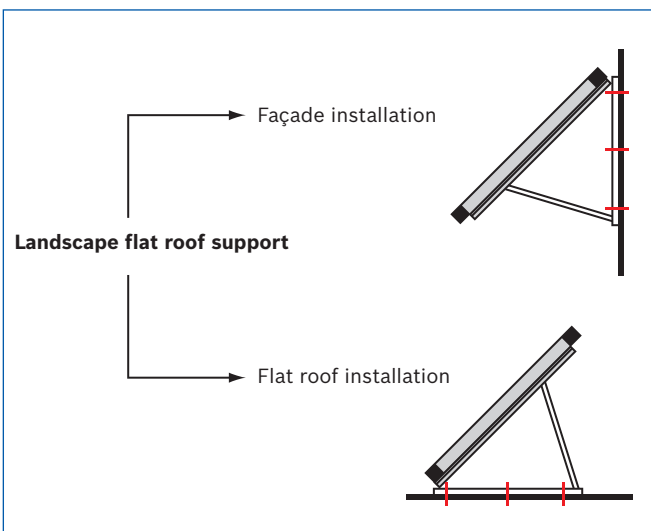

# Greenskies collector pipework connections

## Flat plate connections – Solar-Lifestyle

Worcester Greenskies Solar-Lifestyle collectors are equipped with simple push-fit connections which speed installation and, with bespoke flexible hoses, aid the routing of pipework into the roof space. Once inside the property the system should be run with copper pipe. Flexible hose connections are secured with a simple quick release clip which closes automatically and saves time.

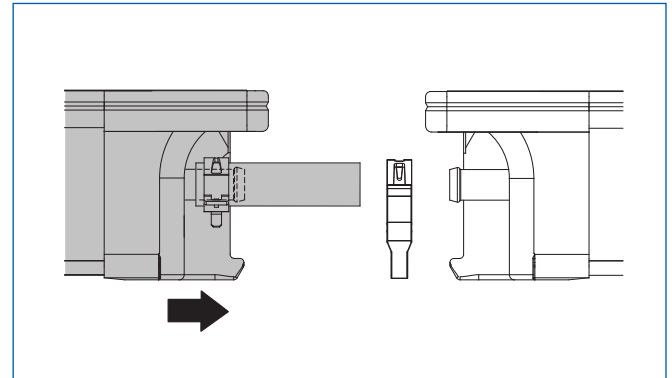

## Greenskies Solar-Lifestyle: other installation considerations

The installation of the Worcester solar system must be carried out in accordance with the relevant requirements for safety, current Wiring Regulations, local Building Regulations, Building Standards (Scotland), (Consolidation) Regulations and Bylaws of the local water company and Health and Safety document No. 63S (Electricity at Work Regulations 1989). It should be in accordance with the relevant recommendations of the following British Standards and Regulations:

- BS 5918:1989
- The Health and Safety at Work Act 1974
- The Management of Health and Safety at Work Regulations 1999
- The Construction (Health, Safety and Welfare) Regulations 1996
- The Construction (Design and Management) Regulations 1994.
- The Lifting Operations and Lifting Equipment Regulations 1998, and any other relevant regulations in force at this time.

The manufacturer's notes must not be taken in any way as overriding statutory regulations.

### Electricity supply

A 3 amp fused spur (complying with BS 1363) with a double pole isolator with a contact separation of 3mm in all poles supplying the controller should be used. The controller must be earthed.

### Sizing

As a general rule, 1 Greenskies Solar-Lifestyle collector should be enough for 100 litres of water, although collectors should be sized for the hot water demand of each property accordingly. Suitable sizing software

should be used where appropriate. More information can be found on the Worcester website at

[www.worcester-bosch.co.uk](http://www.worcester-bosch.co.uk)

### Glycol heat transfer liquid

Worcester Greenskies Solar-Lifestyle collectors should only be used with Tyfocor®L manufactured by Tyforop Chemie GmbH, available from stockists of Worcester Greenskies solar collectors.

### Hot water blending valve

It is recommended a thermostatic blending valve be used in conjunction with the solar cylinder in order to guard against the high hot water temperatures which the system could provide.

### Insulation

Exposed pipework should be insulated according to the high temperatures that the collectors are able to generate. Insulation rated to 150°C must be used.

### Pressure relief valve

The solar pump stations in the Worcester Greenskies solar range are equipped with a 6bar pressure relief valve which should be connected to pipe work that terminates in a suitable container. The solar safety discharge bottle accessory is suitable for Worcester flat plate systems (see page 50 for more details). Alternatively, the pipework can be run to a foul drain or soil stack.

## Solar-Lifestyle 1 collector row

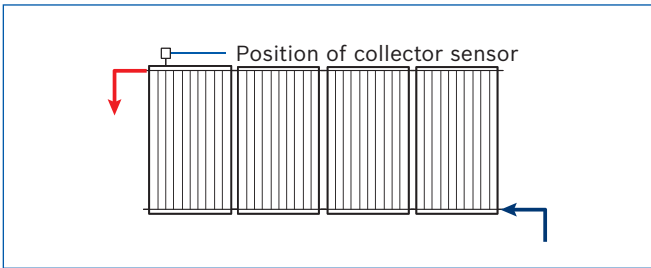

- Left or right sided connection
- Permitted number of collectors: 1-10

The Solar-Lifestyle collectors allow bottom left to top right, or bottom right to top left diagonal connections. All diagrams on this page can be interpreted in this way.

## Solar-Lifestyle 2 collector row

### Series connection

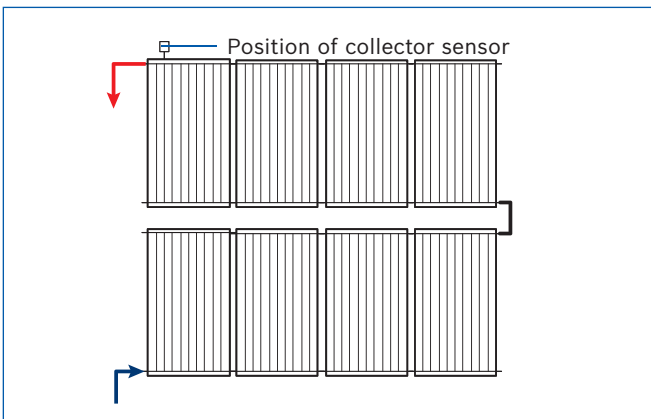

- Permitted number of collectors in each row: 1-5
- Different numbers of collectors between the rows possible

### Parallel connection

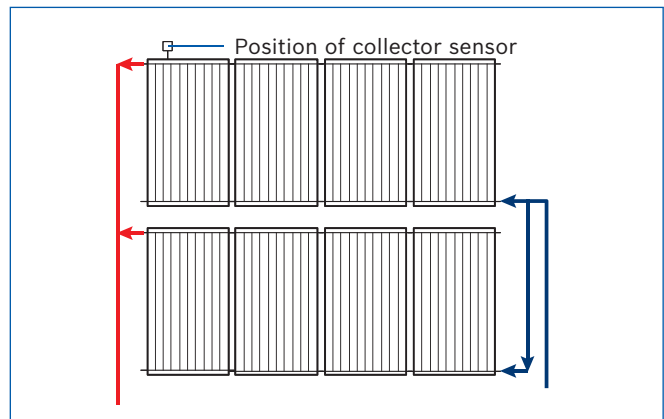

- Permitted number of collectors in each row: 1-10
- Different numbers of collectors between the rows only by regulating of flow rates in each row

## Solar-Lifestyle 3 collector row

### Series connection

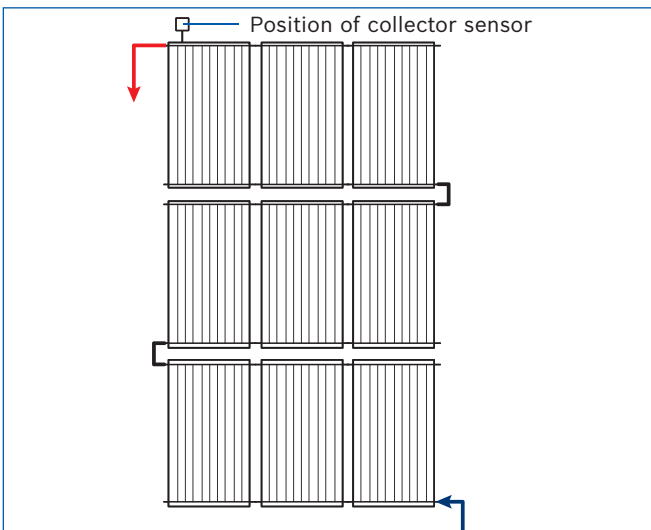

- Permitted number of collectors in each row: 1-3
- Different numbers of collectors between the rows possible

### Parallel connection

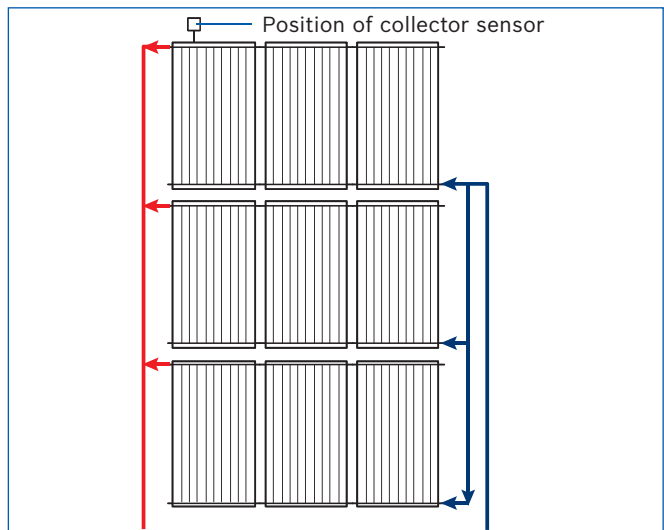







- Permitted number of collectors in each row: 1-10
- Different numbers of collectors between the rows only by regulating of flow rates in each row

# Worcester Greenskies roof kits





Below are the standard Greenskies Solar-Lifestyle roof kits, with the products and quantities outlined. They are specially designed to help with specifying a typical installation.

## Solar-Lifestyle standard roof kits

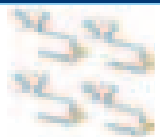

### Greenskies Solar-Lifestyle roof kit – 2 collectors on-roof portrait Part number: 7 716 150 164

<b>Solar-Lifestyle collector portrait</b>  Worcester Part No. 8 718 530 950 Quantity: 2	<b>ICD on-roof portrait rail 1st collector</b>  Worcester Part No. 8 718 531 017	<b>ICD on-roof portrait rail additional collector</b>  Worcester Part No. 8 718 531 018	<b>ICD plain tile roof hook set</b>  Worcester Part No. 8 718 531 023 Quantity: 2	<b>Solar-Lifestyle connection set on-roof</b>  Worcester Part No. 8 718 531 445	<b>Collector sensor</b>  Worcester Part No. 7 747 009 880
---	---	--	--	--	--



### Greenskies Solar-Lifestyle roof kit – 2 collectors on-roof landscape Part number: 7 716 150 166

<b>Solar-Lifestyle collector landscape</b>  Worcester Part No. 8 718 530 951 Quantity: 2	<b>ICD on-roof landscape rail 1st collector</b>  Worcester Part No. 8 718 531 019	<b>ICD on-roof landscape rail additional collector</b>  Worcester Part No. 8 718 531 022	<b>ICD plain tile roof hook set</b>  Worcester Part No. 8 718 531 023 Quantity: 2	<b>Solar-Lifestyle connection set on-roof</b>  Worcester Part No. 8 718 531 445	<b>Collector sensor</b>  Worcester Part No. 7 747 009 880
--	--	---	--	--	--

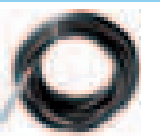
### Greenskies Solar-Lifestyle roof kit – 2 collectors in-roof portrait Part number: 7 716 150 165

<b>Solar-Lifestyle collector portrait</b>  Worcester Part No. 8 718 530 950 Quantity: 2	<b>ICD portrait 2 collector in-roof flashing std tile</b>  Worcester Part No. 8 718 532 910	<b>Solar-Lifestyle connection-set in-roof</b>  Worcester Part No. 8 718 531 446	<b>Collector sensor</b>  Worcester Part No. 7 747 009 880
---	--	--	---

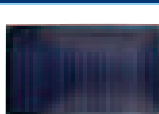
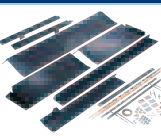

### Greenskies Solar-Lifestyle roof kit – 2 collectors in-roof landscape Part number: 7 716 150 167

<b>Solar-Lifestyle collector landscape</b>  Worcester Part No. 8 718 530 951 Quantity: 2	<b>ICD landscape 2 collector in-roof flashing std tile</b>  Worcester Part No. 8 718 530 987	<b>Solar-Lifestyle connection-set in-roof</b>  Worcester Part No. 8 718 531 446	<b>Collector sensor</b>  Worcester Part No. 7 747 009 880
--	---	--	---

# Custom roof kit creator

By using the simple step-by-step guide in the following tables you can determine all of the components, their appropriate part numbers and the quantity of each item required for a particular installation. Simply choose the quantity of collectors required and follow the column down to find the quantity of each item that is needed.

## Solar-Lifestyle custom on-roof panel option

<b>Step 1:</b> Choose collector quantities and orientation	<b>Portrait – choose how many collectors are required</b>			<b>Quantity required</b>				
	Portrait collector	<b>8 718 530 950</b>	Solar-Lifestyle collector portrait	<b>1</b>	<b>2</b>	<b>3</b>	<b>4</b>	<b>5</b>
	<b>Accompanying rails required for typical row configuration</b>							
	Portrait rails	<b>8 718 531 017</b>	ICD on-roof portrait rail 1st collector	1	1	1	1	1
		<b>8 718 531 018</b>	ICD on-roof portrait rail additional collector	N/A	1	2	3	4
	<b>Landscape – choose how many panels are required</b>							
	Landscape collector	<b>8 718 530 951</b>	Solar-Lifestyle collector landscape	<b>1</b>	<b>2</b>	<b>3</b>	<b>4</b>	<b>5</b>
	<b>Accompanying rails required for typical row configuration</b>							
	Landscape rails	<b>8 718 531 019</b>	ICD on-roof landscape rail 1st collector	1	1	1	1	1
		<b>8 718 531 022</b>	ICD on-roof landscape rail additional collector	N/A	1	2	3	4

<b>Step 2:</b> Choose the roof type	<b>Quantity of collectors chosen in step 1:</b>			<b>1</b>	<b>2</b>	<b>3</b>	<b>4</b>	<b>5</b>
	<b>Roof / hook mounting required</b>			<b>Quantity required</b>				
	Plain / pan tile roof	<b>8 718 531 023</b>	ICD plain tile roof hook set	1	2	3	4	5
	<b>OR</b>							
	Slate / crown tile roof	<b>8 718 531 024</b>	ICD slate / crown tile roof hook set	1	2	3	4	5
	<b>OR</b>							
	Corrugated roof	<b>8 718 531 025</b>	ICD roof mount for corrugated / tin roof set	1	2	3	4	5

<b>Step 3:</b> Include connection set	<b>Quantity of collectors chosen in step 1:</b>			<b>1</b>	<b>2</b>	<b>3</b>	<b>4</b>	<b>5</b>
	<b>Collector connection hose required per total installation</b>			<b>Quantity required</b>				
	On-roof	<b>8 718 531 445</b>	Connection-set on-roof Solar-Lifestyle	1	1	1	1	1

**Step 4:** Move to plumb equipment option – refer to pages 34-35

**Step 5:** Choose your Greenstore solar compatible unvented cylinder – refer to pages 48-49

## Solar-Lifestyle custom in-roof collector option

**Step 1:**  
Choose  
collector  
quantities,  
orientation  
and flashing  
for roof type

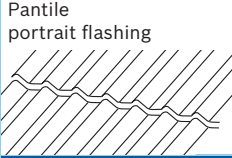
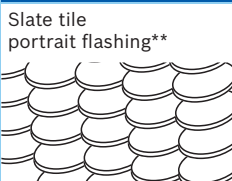
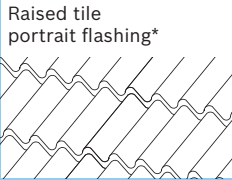
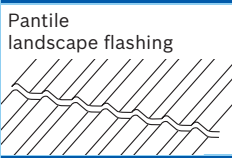
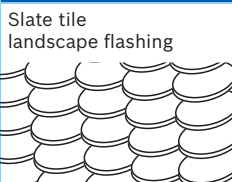
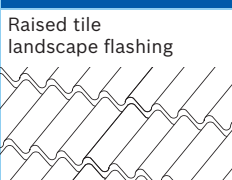
Portrait – choose how many collectors are required			Quantity required				
Portrait collector	<b>8 718 530 950</b>	Solar-Lifestyle collector portrait	<b>1</b>	<b>2</b>	<b>3</b>	<b>4</b>	<b>5</b>
<b>Accompanying flashing required for typical row configuration</b>							
 Pantile portrait flashing	<b>8 718 530 980</b>	ICD portrait 1 collector in-roof flashing	1	N/A	N/A	N/A	N/A
	<b>8 718 532 910</b>	ICD portrait 2 collector in-roof flashing	N/A	1	1	1	1
	<b>8 718 532 911</b>	ICD portrait 1 collector extension in-roof flashing	N/A	N/A	1	2	3
<b>OR</b>							
 Slate tile portrait flashing**	<b>8 718 530 992</b>	ICD portrait 1 collector in-roof flashing slate/shingle	1	N/A	N/A	N/A	N/A
	<b>8 718 532 913</b>	ICD portrait 2 collector in-roof flashing slate/shingle	N/A	1	1	1	1
	<b>8 718 532 914</b>	ICD portrait 1 collector extension in-roof flashing slate/shingle	N/A	N/A	1	2	3
<b>OR</b>							
 Raised tile portrait flashing*	<b>8 718 531 004</b>	ICD portrait 1 collector in-roof flashing raised tile	1	N/A	N/A	N/A	N/A
	<b>8 718 532 916</b>	ICD portrait 2 collector in-roof flashing raised tile	N/A	1	1	1	1
	<b>8 718 532 917</b>	ICD portrait 1 collector extension in-roof flashing raised tile	N/A	N/A	1	2	3
<b>Landscape – choose how many collectors are required</b>			<b>Quantity required</b>				
Landscape collector	<b>8 718 530 951</b>	Solar-Lifestyle collector landscape	<b>1</b>	<b>2</b>	<b>3</b>	<b>4</b>	<b>5</b>
<b>Accompanying flashing required for typical row configuration</b>							
 Pantile landscape flashing	<b>8 718 530 986</b>	ICD landscape 1 collector in-roof flashing	1	N/A	N/A	N/A	N/A
	<b>8 718 530 987</b>	ICD landscape 2 collector in-roof flashing	N/A	1	1	1	1
	<b>8 718 530 988</b>	ICD landscape 1 collector extension in-roof flashing	N/A	N/A	1	2	3
<b>OR</b>							
 Slate tile landscape flashing	<b>8 718 530 998</b>	ICD landscape 1 collector in-roof flashing slate/shingle	1	N/A	N/A	N/A	N/A
	<b>8 718 530 999</b>	ICD landscape 2 collector in-roof flashing slate/shingle	N/A	1	1	1	1
	<b>8 718 531 000</b>	ICD landscape 1 collector extension in-roof flashing slate/shingle	N/A	N/A	1	2	3
<b>OR</b>							
 Raised tile landscape flashing	<b>8 718 531 010</b>	ICD landscape 1 collector in-roof flashing raised tile	1	N/A	N/A	N/A	N/A
	<b>8 718 531 011</b>	ICD landscape 2 collector in-roof flashing raised tile	N/A	1	1	1	1
	<b>8 718 531 012</b>	ICD landscape 1 collector extension in-roof flashing raised tile	N/A	N/A	1	2	3

**Step 2:**  
Include  
connection set

Collector connection hose required per total installation			Quantity required				
In-roof	<b>8 718 531 446</b>	Connection-set in-roof Solar-Lifestyle	1	1	1	1	1

**Step 3:** Move to plumb equipment option – refer to pages 34-35

**Step 4:** Choose your Greenstore solar compatible unvented cylinder – refer to pages 48-49



## Solar-Lifestyle custom flat-roof collector option









<b>Step 1:</b> Choose collector quantities, orientation and flashing for roof type	Portrait – choose how many collectors are required			Quantity required					
	Portrait collector	<b>8 718 530 950</b>	Solar-Lifestyle collector portrait	1	2	3	4	5	
	Accompanying flashing required for typical row configuration								
	Portrait flat-roof stand	<b>8 718 531 031</b>	ICD flat-roof portrait support 1st collector	1	1	1	1	1	
		<b>8 718 531 032</b>	ICD flat-roof portrait support additional collector	N/A	1	2	3	4	
	Landscape – choose how many collectors are required								
	Landscape collector	<b>8 718 530 951</b>	Solar-Lifestyle collector landscape	1	2	3	4	5	
	Accompanying rails required for typical row configuration								
	Landscape flat-roof stand	<b>8 718 531 033</b>	ICD flat-roof landscape support 1st collector	1	1	1	1	1	
		<b>8 718 531 034</b>	ICD flat-roof landscape support additional collector	N/A	1	2	3	4	

<b>Step 2:</b> Include connection set	Collector connection hose required per total installation			Quantity required				
	Flat-roof	<b>8 718 531 447</b>	Connection-set flat-roof Solar-Lifestyle	1	1	1	1	1

**Step 3:** Move to plumb equipment option – refer to pages 34-35

**Step 4:** Choose your Greenstore solar compatible unvented cylinder – refer to pages 48-49

### Greenskies Solar-Lifestyle auxiliary accessories

<b>ICD portrait auxiliary rail 1st collector</b>  <b>Worcester Part No. 8 718 531 026</b>	<b>ICD portrait auxiliary rail additional collector</b>  <b>Worcester Part No. 8 718 531 027</b>	<b>ICD flat-roof portrait auxiliary rail 1 collector</b>  <b>Worcester Part No. 8 718 531 036</b>	<b>ICD flat-roof landscape auxiliary rail 1 collector</b>  <b>Worcester Part No. 8 718 531 037</b>	<b>ICD portrait snow load profile plain tile</b>  <b>Worcester Part No. 8 718 531 028</b>	<b>ICD portrait snow load profile slate/shingle</b>  <b>Worcester Part No. 8 718 531 029</b>
<b>ICD portrait snow load profile corrugated/tin</b>  <b>Worcester Part No. 8 718 531 030</b>	<b>ICD flat-roof loading tray set 1 collector</b>  <b>Worcester Part No. 8 718 531 035</b>				

# Worcester Greenskies plumb kits

To enable flexibility for the installer to choose their preferred combination of Greenskies accessories and also to allow installations where the roof work is done at a different time to the plumbing work, Worcester is proud to offer its solar products in roof kit and plumb kit form.





The standard plumb kits are listed below. For a custom specification use the Custom Plumb Kit Selector.

## Solar-Lifestyle plumb kits

### Plumb kit: standard single Part number: 7 716 150 174

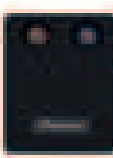
<p>Solar fluid Glycol 'L' 20 litre</p>  <p>Worcester Part No. 8 718 660 881</p>	<p>AGS10E-2 pump station</p>  <p>Worcester Part No. 7 735 600 066</p>	<p>TDS100-2 controller</p>  <p>Worcester Part No. 7 735 600 075</p>	<p>18 litre expansion vessel</p>  <p>Worcester Part No. 7 739 300 100</p>	<p>Expansion vessel connector</p>  <p>Worcester Part No. 7 739 300 331</p>
--	--	--	--	---

### Plumb kit: standard twin Part number: 7 716 150 175

<p>Solar fluid Glycol 'L' 20 litre</p>  <p>Worcester Part No. 8 718 660 881</p>	<p>AGS10-2 pump station</p>  <p>Worcester Part No. 7 735 600 065</p>	<p>TDS100-2 controller</p>  <p>Worcester Part No. 7 735 600 075</p>	<p>25 litre expansion vessel</p>  <p>Worcester Part No. 7 739 300 119</p>	<p>Expansion vessel connector</p>  <p>Worcester Part No. 7 739 300 331</p>
--	---	--	--	---

### Plumb kit: advanced single Part number: 7 716 150 173

<p>Solar fluid Glycol 'L' 20 litre</p>  <p>Worcester Part No. 8 718 660 881</p>	<p>AGS10E-2 pump station</p>  <p>Worcester Part No. 7 735 600 066</p>	<p>CS200</p>  <p>Worcester Part No. 7 738 111 068</p>	<p>MS200</p>  <p>Worcester Part No. 7 738 110 146</p>	<p>18 litre expansion vessel</p>  <p>Worcester Part No. 7 739 300 100</p>	<p>Expansion vessel connector</p>  <p>Worcester Part No. 7 739 300 331</p>
--	--	--	---	--	---

# Custom plumb equipment option for Greenskies Solar-Lifestyle

## Step 1: Choose pump station

Single line pump station	7 735 600 066	Solar pump station AGS10E-2, 1-10 collectors	Choose at least 1 per installation. East west / split requires 1 x single line and 1 x twin line
Twin line pump station	7 735 600 065	Solar pump station AGS10-2, 1-10 collectors	

## Step 2: Choose controller

Standard controller	7 735 600 075	Solar controller TDS100-2	Choose 1 per installation. (Advanced controller required for multiple pump station configurations)
Advanced controller	7 738 111 068 and 7 738 110 146	Solar controller CS200 plus MS200 module	







## Step 3: Choose an expansion vessel

Expansion vessels	7 739 300 100	Expansion vessel 18 litre	Choose 1 per pump station depending on size required
	7 739 300 119	Expansion vessel 25 litre	
	7 739 300 120	Expansion vessel 35 litre	
Expansion connection	7 739 300 331	Solar expansion vessel connection	1 per expansion vessel



## Step 4: Choose glycol quantity

Flat plate glycol	8 718 660 881	Solar fluid 20 litre	At least 20 litre recommended per installation
	8 718 660 880	Solar fluid 10 litre	

## Greenskies Solar-Lifestyle auxiliary accessories

<p><b>Sensors: Additional collector sensor*</b></p>  <p><b>Worcester Part No. 7 747 009 880</b></p> <p><i>*For East/West splits or for custom first fix roof kits</i></p>	<p><b>Sensors: Additional cylinder sensor*</b></p>  <p><b>Worcester Part No. 7 747 009 881</b></p> <p><i>*To enable the end user to view temperature reading from the top cylinder coil</i></p>	<p><b>Pre-cooling: Pre-cooling vessel 5 litre*</b></p>  <p><b>Worcester Part No. 7 747 010 472</b></p> <p><i>*For systems with 60% or greater solar fraction</i></p>	<p><b>Pre-cooling: Pre-cooling vessel 10 litre*</b></p>  <p><b>Worcester Part No. 7 747 010 473</b></p> <p><i>*For systems with 60% or greater solar fraction</i></p>	<p><b>Discharge container: Solar discharge bottle*</b></p>  <p><b>Worcester Part No. 7 716 192 348</b></p> <p><i>*To contain expelled glycol from PRV discharge</i></p>	<p><b>3/4" diverter valve*</b></p>  <p><b>Worcester Part No. 85 103 220</b></p> <p><i>*CS200 and MS200 accessories for advanced system configurations</i></p>
--	--	---	--	--	--

## Greenskies Solar-Lifestyle commissioning and service

<p><b>Electric filling pump</b></p>  <p><b>Worcester Part No. 8 718 530 473</b></p>	<p><b>Solar service kit</b></p>  <p><b>Worcester Part No. 7 739 300 397</b></p>
--	--

# Greenskies Solar-Lito

The Solar-Lito range of collectors offers the homeowner affordable solar hot water comfort, whilst also allowing flexible solutions for the installer.

Like the Solar-Lifestyle, the Greenskies Solar-Lito collectors also feature an attractive aluminium one-piece construction. This makes the collector light weight, the lightest in its class, weighing in at 30kg.

Collector type	Solar-Lito
Orientation	Portrait
Dimensions	1032x2026x67mm
Gross collector area	2.09m <sup>2</sup>
Aperture area	1.94m <sup>2</sup>
Absorber area	1.92m <sup>2</sup>
Absorber volume	0.8 litres
Weight empty	30kg
Absorption	95 ± 2%
Emissions	10 ± 2%
η <sub>0</sub>	76.1%
a <sub>1</sub>	4.083 W/m <sup>2</sup> k
a <sub>2</sub>	0.012 W/m <sup>2</sup> k <sup>2</sup>
ErP collector efficiency	58%
1,000 W/m <sup>2</sup>	
ΔT = 0K	1474 W/m <sup>2</sup>
ΔT = 30K	1215 W/m <sup>2</sup>
ΔT = 50K	1020 W/m <sup>2</sup>
Stagnation temperature tstg.	194°C
Max. operation pressure pmax	6 bar
Nominal flow rate [l/h]	50 litres/hour
Incident Angle Modifier (50T)	0.94
MCS certification number	011-7S 1926F
Part number	8 718 532 279

*W = power (instant power)*

## Greenskies Solar-Lito collector close up

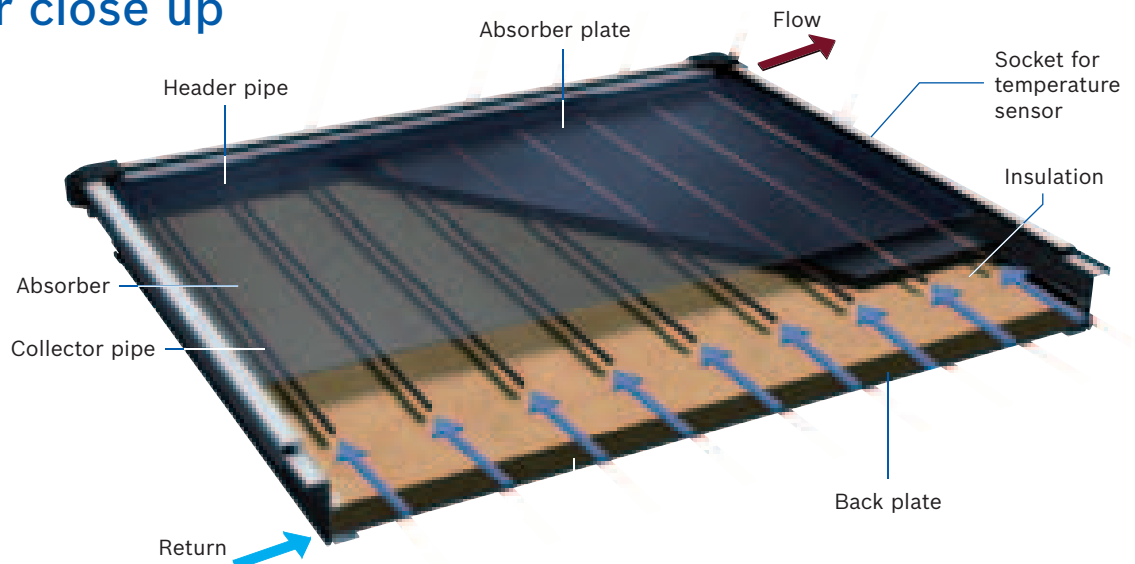

## Installation options

Our Solar-Lito flat plate collectors can be installed on-roof or in a flat-roof arrangement. They cater for standard concrete pantile, slate and corrugated metal roof surfaces.

The Solar-Lito can be installed in a first and second fix as the roof kits and hydraulic plumb kits are available in two separate packs. This allows a specialist roofer to fit the roof mounting kit prior to the commissioning of the system if required. It also ensures only the necessary kit is on site when needed.



Slate/shingle



Standard concrete pantile



Metal corrugated

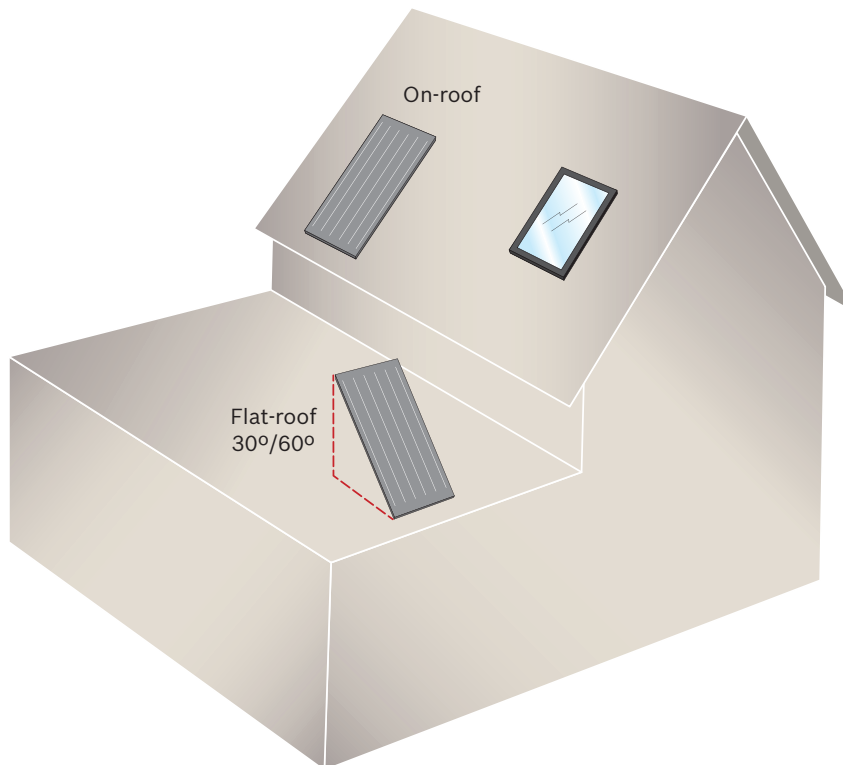

# Greenskies Solar-Lito on-roof installation guide

## Solar-Lito

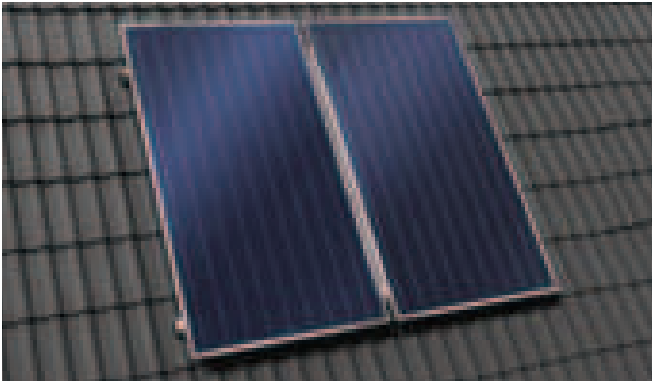

### Dimensions A and B

Surface area required for collectors.

### Dimension C

At least two free rows of tiles to the roof peak or chimney. Especially in the case of wet tiles, there is risk of damaging the roof\*.

### Dimension D

Prominence of the roof, including the thickness of the façade of the building.

### Dimension E

At least 30cm should be cleared for the installation of the connection cables in the attic below.

### Dimension F

At least 40cm for the installation of the connection cables in the attic, above (when installing the retainer, make sure that there is sufficient space in the water outlet area).

### Dimension G

At least 50cm on the left and on the right of the collector array for the connection cables under the roof.

### Dimension H

Dimension H corresponds to 1,900mm and is the minimum distance from the upper corner of the collector until the middle of the lower rail, which is fixed first.

## Collectors dimensions and clearances

Please observe the following minimum space requirements.

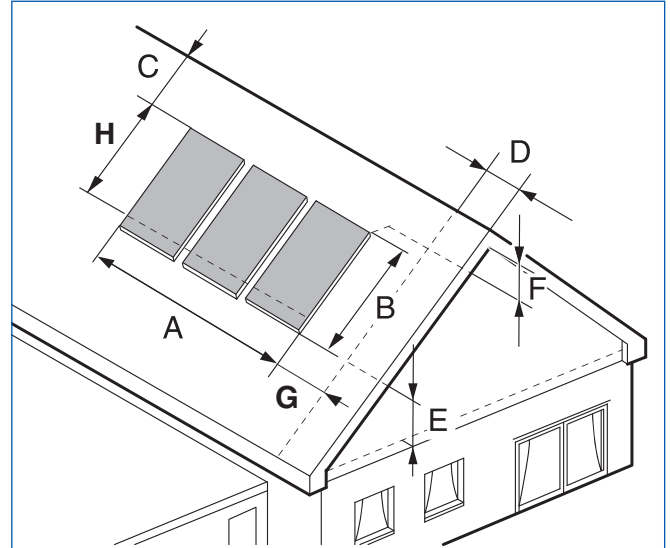

### Required distance for vertical collectors

No. of collectors	Dimension A	Dimension B
1	1,095m	2,026m
2	2,196m	2,026m
3	3,296m	2,026m
4	4,397m	2,026m
5	5,497m	2,026m
6	6,598m	2,026m
7	7,698m	2,026m
8	8,799m	2,026m
9	9,899m	2,026m
10	11,000m	2,026m

Space requirements for vertical collectors

## On-roof mounting kit

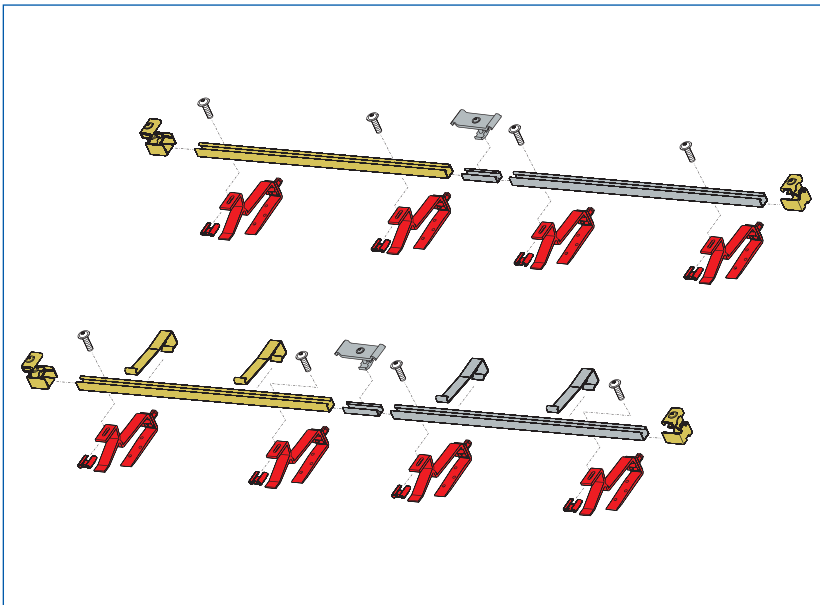

Key	
	Profile rail – 1st collector
	Single-sided collector clamp
	Roof hook, adjustable
	Sliding nut
	Additional profile rail
	Double-sided collector clamp
	Additional rail collector connector with threaded studs
	Anti-slip protector

## Greenskies Solar-Lito portrait

- Wind loads: up to 1.1kN/m<sup>2</sup> (~151km/h)
- Snow loads: up to 2.0kN/m<sup>2</sup>

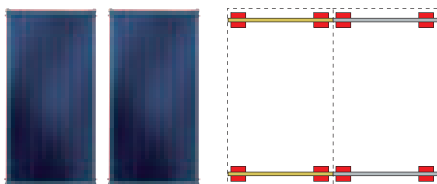
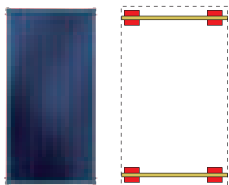

**Please note: various different shapes can be achieved by adding multiple rows of collectors. Each additional row requires a series hose connection set (part number 8 718 531 940).**

# Greenskies Solar-Lito flat-roof installation guide



The minimum clearance X between the collectors results from the collectors' angle of incidence. Clearance between the rows of collectors at minimum solar altitude (on a flat-roof: 17°; on a wall: 61°).

## Shadow clearance

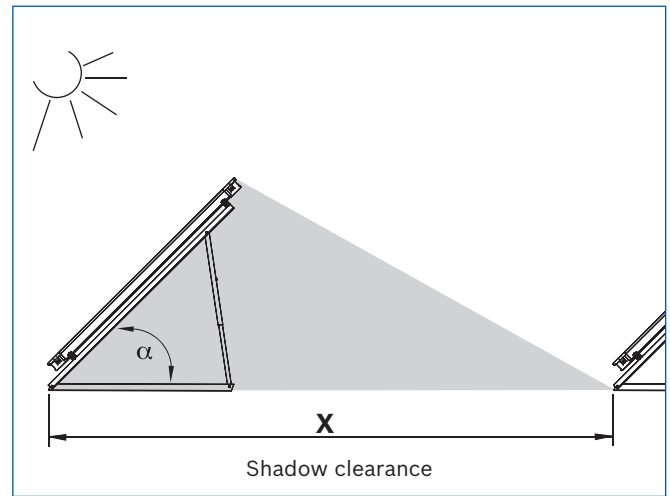

Determining the clearance between rows of collectors	
Angle of incidence $\alpha$	Clearance X – flat-roof
	Portrait
30°	5.06m
35°	5.45m
40°	5.80m
45°	6.11m
50°	6.37m
55°	6.58m
60°	6.74m

## Greenskies Solar-Lito flat-roof options

### Greenskies Solar-Lito collectors







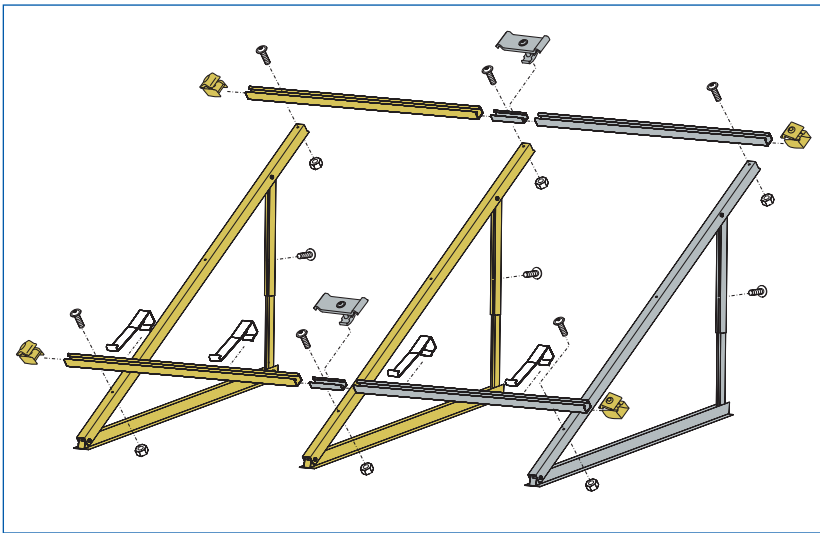

**Flat support by conventional fitting or loading tray set**

- Wind speed  $\leq 151\text{km/h}$
- Snow loads  $\leq 2\text{kN/m}^2$

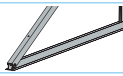

## Flat-roof mounting kit



Key	
	Profile rail – 1st collector
	Collector brace – 1st collector
	Single-sided collector clamp
	Additional profile rail
	Additional collector brace
	Double-sided collector clamp
	Additional collector connector
	Anti-slip protector

### Fixed loading tray set or conventional fitting

The Worcester Greenskies flat-roof mounting kits can be secured to the roof in two ways. Firstly a loading tray set can be attached to the mounting kits, which weighs down the collectors (see page 44) or secondly they can be secured by a conventional fitting, directly attaching the collectors onto the roof surface.

### Greenskies Solar-Lito portrait collectors

#### Using auxiliary rail for flat-roof support fixed by loading tray set

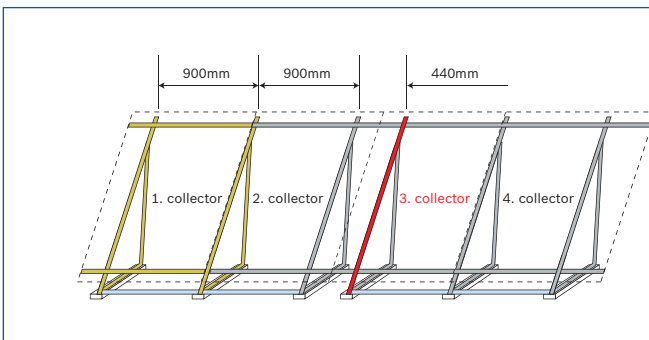

- Wind speed  $\leq 151\text{km/h}$
- Snow loads  $\leq 2\text{kN/m}^2$

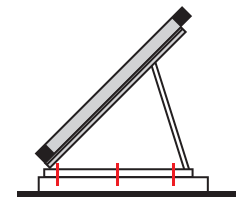

### Greenskies Solar-Lito portrait collectors

#### Using auxiliary rail for flat-roof support fixed by conventional set

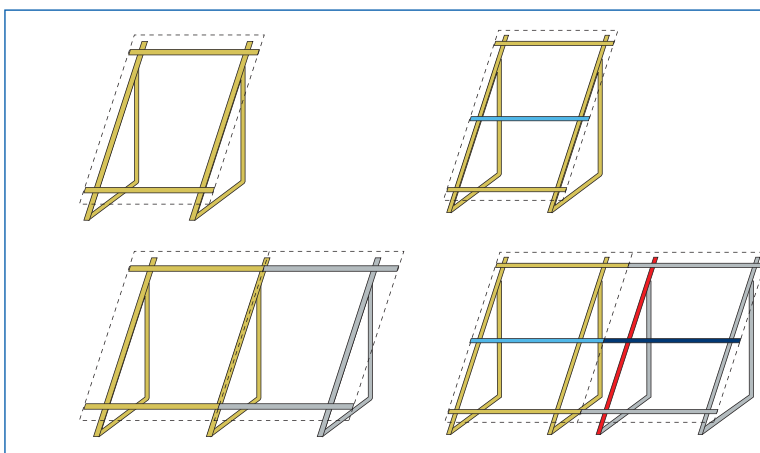

- Wind speed  $\leq 151\text{km/h}$
- Snow loads  $> 2\text{kN/m}^2 - 3.8\text{ kN/m}^2$

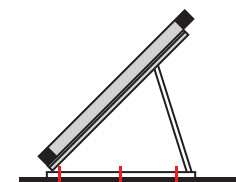

# Wind speed: fixing of flat-roof supports

It is important to check the maximum possible load of the roof.

Corresponding wind speed	Fixing by customer or external support	Fixing by loads (loading tray set)	Fixing by loads and additional cable
103km/h	2 x M8/8.8	246kg	149kg/collector + cable with 2.0kN traction
130km/h	2 x M8/8.8	426kg	291kg/collector + cable with 3.0kN traction
151km/h	2 x M8/8.8	616kg	431kg/collector + cable with 4.0kN traction

## Example of 5 and 10 collectors

- Wind speed  $\leq 151\text{km/h}$
- Snow loads  $\leq 2\text{kN/m}^2$

- Flat roof support basic set, vertical
- Flat roof support extension set, vertical
- Loading tray set
- Auxiliary rail flat roof support, horizontal, needed for collector row with 3rd, 6th or 9th collectors and at the end row  $\leq 3\text{rd}$ , 6th or 9th collectors

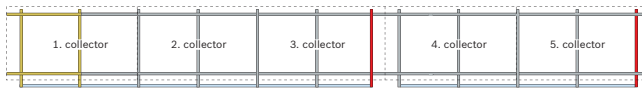

# Greenskies Solar-Lito: hydraulic connections

The Solar-Lito collectors can be combined together or installed separately in a range of flexible configurations to suit awkward roof shapes or even to more accurately size a solar output to the solar cylinder.

There are a few simple rules to observe when designing a Lito installation.

- The Solar-Lito collectors are always connected in series and not in parallel
- The sensor pocket on the Solar-Lito is positioned on the top right hand side of the collectors. This means that any hydraulic configurations must be aligned so that the flow line is connected to the top right hand corner of the end collector in the configuration
- Any Lito collectors on the same row require one 1st collector rail set, and then an additional collector rail set for each subsequent collector on that same row.

## Shape schematics

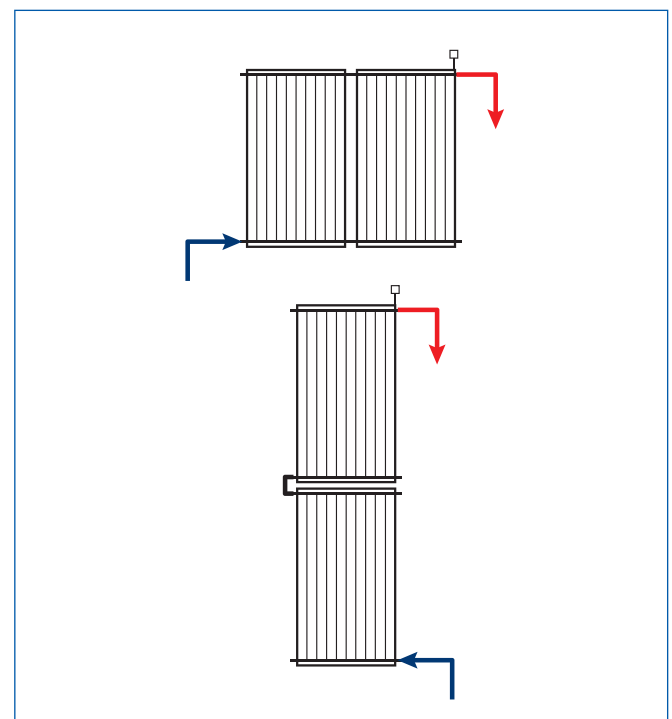

Example Solar-Lito hydraulics schematics

# Greenskies collector pipework connections

## Flat plate connections – Solar-Lito

Worcester Greenskies Solar-Lito collectors are equipped with simple push-fit connections which speed installation and, with bespoke flexible hoses, aid the routing of pipework into the roof space. Once inside the property the system should be run with copper pipe. Flexible hose connections are secured with a simple quick release clip which closes automatically and saves time.

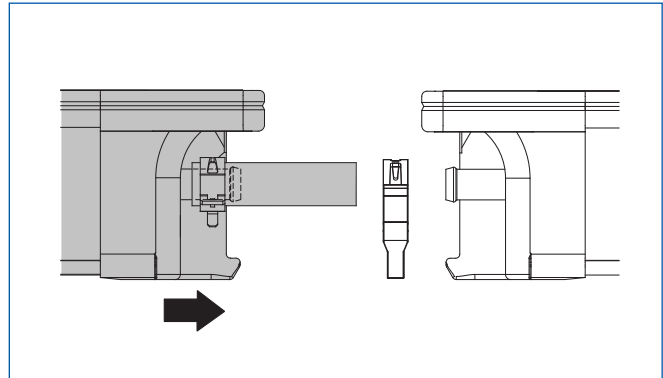

## Greenskies Solar-Lito: other installation considerations

The installation of the Worcester solar system must be carried out in accordance with the relevant requirements for safety, current Wiring Regulations, local Building Regulations, Building Standards (Scotland), (Consolidation) Regulations and Bylaws of the local water company and Health and Safety document No. 63S (Electricity at Work Regulations 1989). It should be in accordance with the relevant recommendations of the following British Standards and Regulations:

- BS 5918:1989
- The Health and Safety at Work Act 1974
- The Management of Health and Safety at Work Regulations 1999
- The Construction (Health, Safety and Welfare) Regulations 1996
- The Construction (Design and Management) Regulations 1994
- The Lifting Operations and Lifting Equipment Regulations 1998, and any other relevant regulations in force at this time.

The manufacturer's notes must not be taken in any way as overriding statutory regulations.

### Electricity supply

A 3 amp fused spur (complying with BS 1363) with a double pole isolator with a contact separation of 3mm in all poles supplying the controller should be used. The controller must be earthed.

### Sizing

As a general rule, 1 Greenskies Solar-Lito should be enough for 100 litres of water; although collectors should be sized for the hot water demand of each property accordingly. Suitable sizing software should be used where appropriate. More information can be found on the Worcester website at [www.worcester-bosch.co.uk](http://www.worcester-bosch.co.uk)

### Glycol heat transfer liquid

Worcester Greenskies Solar-Lito collectors should only be used with: Tyfocor©L manufactured by Tyforop Chemie GmbH, available from stockists of Worcester Greenskies solar collectors.

### Hot water blending valve

It is recommended a thermostatic blending valve be used in conjunction with the solar cylinder in order to guard against the high hot water temperatures which the system could provide.

### Insulation

Exposed pipework should be insulated according to the high temperatures that the collectors are able to generate. Insulation rated to 150°C must be used.

### Pressure relief valve





The solar pump stations in the Worcester Greenskies solar range are equipped with a 6bar pressure relief valve which should be connected to pipe work that terminates in a suitable container. The Solar safety discharge bottle accessory is suitable for Worcester flat plate systems. Alternatively, the pipework can be run to a foul drain or soil stack.

# Worcester Greenskies roof kits



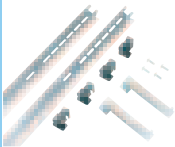

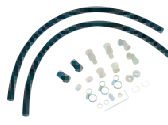
Below are the standard Greenskies Solar-Lito roof kits, with the products and quantities outlined. They are specially designed to help with specifying a typical installation.

## Solar-Lito standard roof kits



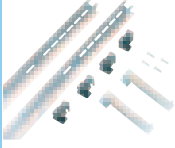

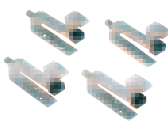
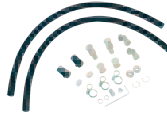
### Greenskies Solar-Lito roof kit – 1 collector Part number: 7 716 150 168

<p><b>Solar-Lito collector</b></p>  <p>Worcester Part No. 8 718 532 279</p>	<p><b>Solar-Lito rail 1st collector</b></p>  <p>Worcester Part No. 7 709 600 087</p>	<p><b>Std roof hook plain tile FKA3</b></p>  <p>Worcester Part No. 7 739 300 436</p>	<p><b>Solar-Lito connection set on-roof</b></p>  <p>Worcester Part No. 8 718 531 941</p>	<p><b>Collector sensor</b></p>  <p>Worcester Part No. 7 747 009 880</p>
--	---	---	--	--

### Greenskies Solar-Lito roof kit – 2 collectors Part number: 7 716 150 169

<p><b>Solar-Lito collector</b></p>  <p>Worcester Part No. 8 718 532 279 Quantity: 2</p>	<p><b>Solar-Lito rail 1st collector</b></p>  <p>Worcester Part No. 7 709 600 087</p>	<p><b>Solar-Lito rail additional collector</b></p>  <p>Worcester Part No. 7 709 600 088</p>	<p><b>Std roof hook plain tile FKA3</b></p>  <p>Worcester Part No. 7 739 300 436 Quantity: 2</p>	<p><b>Solar-Lito connection set on-roof</b></p>  <p>Worcester Part No. 8 718 531 941</p>	<p><b>Collector sensor</b></p>  <p>Worcester Part No. 7 747 009 880</p>
--	---	--	--	---	--

### Greenskies Solar-Lito auxiliary accessories



<p><b>Solar-Lito flat roof portrait support 1st collector</b></p>  <p>Worcester Part No. 8 718 531 943</p>	<p><b>Solar-Lito flat roof additional rail support</b></p>  <p>Worcester Part No. 8 718 531 945</p>	<p><b>Solar-Lito flat roof additional load rail</b></p>  <p>Worcester Part No. 8 718 531 036</p>	<p><b>Solar-Lito flat roof loading tray set for 1 collector</b></p>  <p>Worcester Part No. 7 739 300 458</p>
---	--	---	--

# Custom roof kit creator

By using the simple step-by-step guide in the following tables you can determine all of the components, their appropriate part numbers and the quantity of each item required for a particular installation. Simply choose the quantity of collectors required and follow the column down to find the quantity of each item that is needed.

## Solar-Lito custom on-roof collectors option

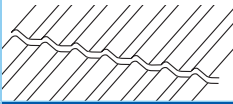
<b>Step 1:</b> Choose collector quantities and orientation	Lito – choose how many collectors are required			Quantity required					
	Lito collector	8 718 532 279	Solar-Lito collector	1	2	3	4	5	6
	Accompanying rails required for typical row configuration								
	Rails 	7 709 600 087	On-roof rail 1st collector	1	1	1	1	1	1
	7 709 600 088	On-roof rail additional collector	N/A	1	2	3	4	5	

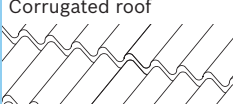
<b>Step 2:</b> Choose the roof type	Quantity of collectors chosen in step 1:			1	2	3	4	5	6
	Roof / hook mounting required			Quantity required					
		7 739 300 436	Std roof hook plain tile	1	2	3	4	5	6
	OR								
		7 739 300 281	Std slate / crown tile hook	1	2	3	4	5	6
	OR								
	7 739 300 439	Std roof studs corrugated / tin roof	1	2	3	4	5	6	

<b>Step 3:</b> Include connection set	Collector connection hose required per total installation			Quantity required					
	On-roof	8 718 531 941	Connection set Solar-Lito on-roof	1	1	1	1	1	1

**Step 4:** Move to plumb equipment option – refer to pages 46-47

**Step 5:** Choose your Greenstore solar compatible unvented cylinder – refer to pages 48-49





# Worcester Greenskies plumb kits

To enable flexibility for the installer to choose their preferred combination of Greenskies accessories and also allow installations where the roof work is done at a different time to the plumbing work, Worcester is proud to offer its solar products in roof kit and plumb kit form.



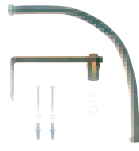

The standard plumb kits are listed below. For a custom specification use the Custom Plumb Kit Selector.

## Solar-Lito plumb kits

### Plumb kit: standard single Part number: 7 716 150 174

<b>Solar fluid Glycol 'L' 20 litre</b>  <b>Worcester Part No. 8 718 660 881</b>	<b>AGS10E-2 pump station</b>  <b>Worcester Part No. 7 735 600 066</b>	<b>TDS100-2 controller</b>  <b>Worcester Part No. 7 735 600 075</b>	<b>18 litre expansion vessel</b>  <b>Worcester Part No. 7 739 300 100</b>	<b>Expansion vessel connector</b>  <b>Worcester Part No. 7 739 300 331</b>
---	---	---	---	--

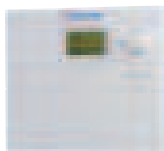
### Plumb kit: standard twin Part number: 7 716 150 175

<b>Solar fluid Glycol 'L' 20 litre</b>  <b>Worcester Part No. 8 718 660 881</b>	<b>AGS10-2 pump station</b>  <b>Worcester Part No. 7 735 600 065</b>	<b>TDS100-2 controller</b>  <b>Worcester Part No. 7 735 600 075</b>	<b>25 litre expansion vessel</b>  <b>Worcester Part No. 7 739 300 119</b>	<b>Expansion vessel connector</b>  <b>Worcester Part No. 7 739 300 331</b>
--	---	--	--	---

### Plumb kit: advanced single Part number: 7 716 150 173

<b>Solar fluid Glycol 'L' 20 litre</b>  <b>Worcester Part No. 8 718 660 881</b>	<b>AGS10E-2 pump station</b>  <b>Worcester Part No. 7 735 600 066</b>	<b>CS200</b>  <b>Worcester Part No. 7 738 111 068</b>	<b>MS200</b>  <b>Worcester Part No. 7 738 110 146</b>	<b>18 litre expansion vessel</b>  <b>Worcester Part No. 7 739 300 100</b>	<b>Expansion vessel connector</b>  <b>Worcester Part No. 7 739 300 331</b>
--	--	--	---	--	---

# Plumb equipment option for Solar-Lito

## Step 1: Choose pump station

Single line pump station	7 735 600 066	Solar pump station AGS10E-2, 1-10 collectors	Choose at least 1 per installation. East west / split requires 1 x single line and 1 x twin line
Twin line pump station	7 735 600 065	Solar pump station AGS10-2, 1-10 collectors	

## Step 2: Choose controller

Standard controller	7 735 600 075	Solar controller TDS100-2	Choose 1 per installation. (Advanced controller required for multiple pump station configurations)
Advanced controller	7 738 111 068 and 7 738 110 146	Solar controller CS200 plus MS200 module	







## Step 3: Choose an expansion vessel

Expansion vessels	7 739 300 100	Expansion vessel 18 litre	Choose 1 per pump station depending on size required
	7 739 300 119	Expansion vessel 25 litre	
	7 739 300 120	Expansion vessel 35 litre	
Expansion connection	7 739 300 331	Solar expansion vessel connection	1 per expansion vessel



## Step 4: Choose glycol quantity

Flat plate glycol	8 718 660 881	Solar fluid 20 litre	At least 20 litre recommended per installation
	8 718 660 880	Solar fluid 10 litre	

## Greenskies Solar-Lito auxiliary accessories

<p><b>Sensors: Additional collector sensor*</b></p>  <p><b>Worcester Part No. 7 747 009 880</b></p> <p><i>*For East/West splits or for custom first fix roof kits</i></p>	<p><b>Sensors: Additional cylinder sensor*</b></p>  <p><b>Worcester Part No. 7 747 009 881</b></p> <p><i>*To enable the end user to view temperature reading from the top cylinder coil.</i></p>	<p><b>Pre-cooling: Pre-cooling vessel 5 litre*</b></p>  <p><b>Worcester Part No. 7 747 010 472</b></p> <p><i>*For systems with 60% or greater solar fraction</i></p>	<p><b>Pre-cooling: Pre-cooling vessel 10 litre*</b></p>  <p><b>Worcester Part No. 7 747 010 473</b></p> <p><i>*For systems with 60% or greater solar fraction</i></p>	<p><b>Discharge container: Solar discharge bottle*</b></p>  <p><b>Worcester Part No. 7 716 192 348</b></p> <p><i>*To contain expelled glycol from PRV discharge</i></p>	<p><b>3/4" diverter valve*</b></p>  <p><b>Worcester Part No. 85 103 220</b></p> <p><i>*CS200 and MS200 accessories for advanced system configurations</i></p>
--	---	---	--	--	--

## Greenskies Solar-Lito commissioning and service

<p><b>Electric filling pump</b></p>  <p><b>Worcester Part No. 8 718 530 473</b></p>	<p><b>Solar service kit</b></p>  <p><b>Worcester Part No. 7 739 300 397</b></p>
--	--

# The Greenstore solar compatible unvented cylinder series

## Unvented duplex stainless steel twin-coil cylinders

Worcester's Greenstore solar compatible, stainless steel hot water storage cylinders have been specifically designed for use with solar heating installations, although installations incorporating two boilers are also possible. As such, they offer outstanding efficiency, ease of installation and full compliance with current and anticipated legislation and best practice.

Developed and manufactured by Bosch Thermotechnology Ltd, the Greenstore solar compatible unvented series comprises of five models which range from the TC-150 up to the TC-300. All models feature high levels of insulation and dedicated solar volumes in compliance with current Building Regulations, SAP 2012 and the Microgeneration Certification Scheme (MCS).



## Greenstore solar compatible unvented cylinder series features and benefits

Feature	Benefit
65mm of factory-fitted insulation	Very low stand-by heat loss
Dedicated solar volume in accordance with MCS Scheme	Access to the solar thermal Renewable Heat Incentive (RHI) funding
Multiple sensor/thermostat pockets	Allows flexible and easy system integration for flexible control solutions
Wider range (TC-150 to TC-300)	Optimised hot water storage for Greenskies flat plate solar panel series
Stand-by heat loss meets current Building Regulations	Future-proofed product

### Installer benefits

The Greenstore solar compatible unvented cylinder series has been designed very much with the needs of the installer in mind:

- The Greenstore solar compatible unvented cylinder design offers higher levels of flexibility and system integration, making it easier for installers to tailor systems to suit a wide range of layouts. Multiple sensor/thermostat pockets provide flexible control solutions, with enhanced integration to other heat sources such as gas or oil-fired boilers, as well as full compatibility with Worcester control systems
- The TC-150 cylinder offers optimised hot water storage capacity for Worcester Greenskies Solar range
- Greenstore solar compatible unvented cylinders are supplied complete with a G3 accessory kit and include a factory-installed temperature and pressure relief valve and a pre-installed 3kW electrical immersion heater
- All components fitted or supplied with a Greenstore TC cylinder carry a 2 year guarantee
- The stainless steel shell is guaranteed for 25 years, subject to terms and conditions.

### Benefits to the customer

- Customers who opt for solar heating are very focused on energy efficiency and carbon emissions and the Greenstore solar compatible unvented cylinder series is designed to address these priorities
- All cylinders offer high standards of heat retention (65mm insulation), with much lower stand-by heat losses than most competing products. In fact, the cylinders exceed the requirements of the Building Regulations 2010 Part L
- Greenstore solar compatible unvented cylinders are also fully MCS compliant with a dedicated solar volume of 25 litres of storage per m<sup>2</sup> of solar panel installation. This compliance is vital in enabling customers to gain access to funding from the solar thermal Renewable Heat Incentive.



# The Greenstore solar compatible unvented cylinder series at a glance

		Greenstore solar compatible unvented cylinder			
<b>Diameter</b>		570mm			
<b>Height</b>	<b>Greenstore TC-150</b>	1,285mm			
	<b>Greenstore TC-180</b>	1,490mm			
	<b>Greenstore TC-210</b>	1,665mm			
	<b>Greenstore TC-250</b>	1,860mm			
	<b>Greenstore TC-300</b>	2,155mm			
<b>Weight (dry)</b>	<b>Greenstore TC-150</b>	41kg			
	<b>Greenstore TC-180</b>	45kg			
	<b>Greenstore TC-210</b>	50kg			
	<b>Greenstore TC-250</b>	54kg			
	<b>Greenstore TC-300</b>	60kg			
<b>Thermostat pockets</b>		4x thermostat pockets internal diameter 20.4mm			
<b>DHW cold – in</b>		22mm			
<b>DHW hot – out</b>		22mm			
<b>Primary coil (boiler or solar)</b>		22mm			
<b>Secondary coil</b>		22mm			
<b>Secondary return</b>		22mm			
<b>Balanced pressure cold water outlet</b>		22mm			
<b>Pressure relief valve</b>		15mm			
<b>Global Warming Potential (GWP)</b>		3.3			
		<b>Surface area of HE coil (m<sup>2</sup>)</b>	<b>Standing heat loss performance</b>	<b>Reheat time – 100% (15-60°C)</b>	<b>ErP energy efficiency class/Standing heat loss</b>
	<b>Greenstore TC-150</b>	0.657	1.632kWh/24hrs	14 minutes	C / 68W
	<b>Greenstore TC-180</b>	0.657	1.824kWh/24hrs	17 minutes	C / 76W
	<b>Greenstore TC-210</b>	0.845	1.944kWh/24hrs	12 minutes	C / 81W
	<b>Greenstore TC-250</b>	0.845	2.136kWh/24hrs	13 minutes	C / 89W
	<b>Greenstore TC-300</b>	0.845	2.304kWh/24hrs	24 minutes	C / 96W
<b>Storage volume</b>		<b>Total capacity</b>	<b>Dedicated solar volume</b>	<b>Max. absorber area for MCS compliance</b>	
	<b>Greenstore TC-150</b>	157 litres	65 litres	2.6m <sup>2</sup>	
	<b>Greenstore TC-180</b>	187 litres	65 litres	2.6m <sup>2</sup>	
	<b>Greenstore TC-210</b>	211 litres	105 litres	4.2m <sup>2</sup>	
	<b>Greenstore TC-250</b>	241 litres	115 litres	4.4m <sup>2</sup>	
	<b>Greenstore TC-300</b>	287 litres	115 litres	4.4m <sup>2</sup>	

<b>Part number</b>	<b>Cylinder</b>
7 716 800 542	Greenstore TC-150 Cylinder
7 716 800 543	Greenstore TC-180 Cylinder
7 716 842 042	Greenstore TC-210 Cylinder
7 716 842 043	Greenstore TC-250 Cylinder
7 716 842 044	Greenstore TC-300 Cylinder

# Greenskies plumbing considerations

## Pump station configuration options

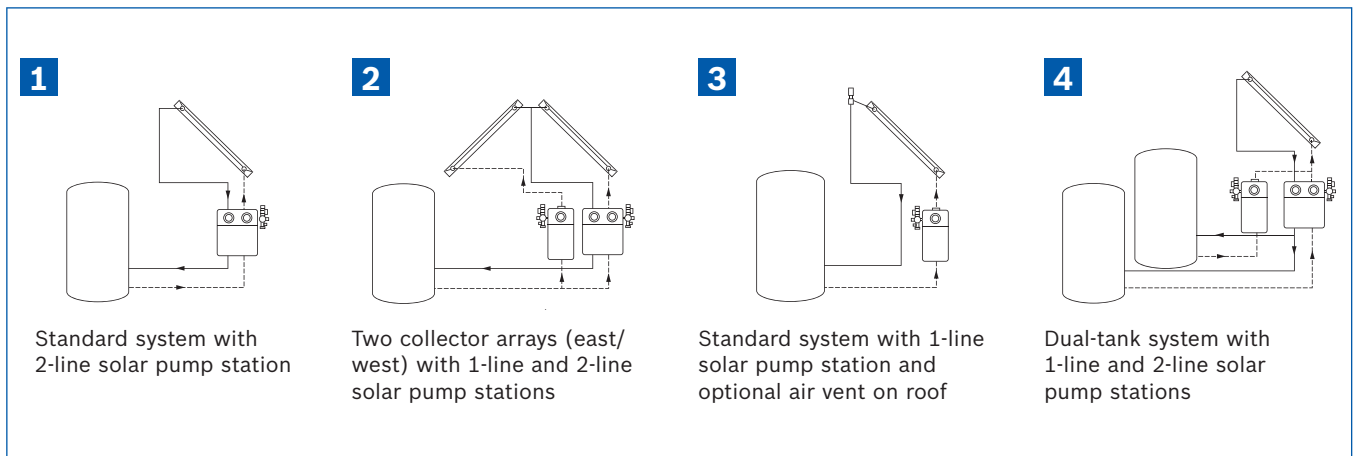

## Solar safety discharge bottle – important information

The solar discharge bottle is designed to provide a neater and safer method of discharge for the PRV outlet.

The discharge bottle is compliant with best practice and future standards, which state that the receptacle should be able to contain the entire contents of the system above the safety valve.

### Benefits for customers

Customers benefit from the peace of mind that, unlike many current solutions, this discharge bottle is

fully tested to ensure safety under normal operating conditions. Also it is see-through, so that customers can see any discharge and notify the installer that there may be a problem.

**The solar discharge bottle is recommended only for use in flat plate solar systems.**



### Product info

Part number 7 716 192 348

Acceptable total pipe lengths in total (flow and return)						
Number of panels	Solar-Lifestyle portrait		Solar-Lifestyle landscape		Solar-Lito	
	15mm	22mm	15mm	22mm	15mm	22mm
1	56	25	53	24	57	26
2	49	22	44	20	51	23
3	43	19	35	15	46	21
4	36	16	26	11	40	18
5	30	14	16	–	35	8.9
6	24	10	–	–	29	13
7	17	–	–	–	24	11
8	–	–	–	–	19	8
9	–	–	–	–	13	–
10	–	–	–	–	–	–

Shown in the table are permissible total combined flow and return pipe lengths (for either 15mm or 22mm pipework) for typical Worcester flat panel systems. If longer total pipework than the values shown is installed an alternative suitable discharge receptacle should be used.

# Homeowner FAQs

## **Q. What is sustainable energy?**

A. Sustainable energy is best thought of as energy which can be replenished within a human lifetime and which causes no long-term damage to the environment. Solar energy, wind energy and geothermal energy, amongst others, are all self-sustaining. They all have sources that cannot be depleted. Extended use of these energy sources aids the conservation of other non-renewable energy sources such as fossil fuels.

## **Q. How does solar technology work?**

A. The idea behind technologies which use solar energy is to harness the freely available rays from the sun in a useful form. The technology used for solar water heating is simple and effective. The basic principle uses an absorber plate which is heated by the sun's rays. This heat is collected in a transfer liquid which is in turn used in a heat exchanger to heat water.

## **Q. What if there is no sun or it is a cloudy day?**

A. Special coatings are available on the absorber plates which allow the collector to absorb energy from diffused as well as direct sunlight. This means the panel can still yield results on days when there are clouds in the sky.

## **Q. Is there any Government funding available?**

A. Solar thermal installations in England, Scotland and Wales which are installed from October 2012 by MCS accredited installers can qualify for tariff payments under the Government's Renewable Heat Incentive (RHI) scheme. The scheme is open to homeowners, tenants, landlords and businesses and is guaranteed for 20 years. Payments are based on the size of the installation and the energy generated.

To find out more visit the Ofgem website at:

**[www.ofgem.gov.uk/environmental-programmes/  
domestic-renewable-heat-incentive](http://www.ofgem.gov.uk/environmental-programmes/domestic-renewable-heat-incentive)**

## **Q. Do I have to pay VAT for installing solar panels?**

A. The VAT on solar systems varies depending on who is installing it. DIY solar systems carry 20% VAT. A system which is installed by a professional VAT registered installer carries 5% VAT. For further information visit: **[www.hm-treasury.gov.uk](http://www.hm-treasury.gov.uk)**

## **Q. Do I still need a boiler?**

A. Solar heating on a normal domestic scale in the UK will provide around 50-70% of the average annual household hot water requirements. Although the system may provide most of the hot water required in summer, the winter results, due to the lower intensity of the sun and the shorter daylight hours, will be reduced. As such the householder will need a boiler (or suitable alternative) to make up the difference in domestic hot water requirement and for the entire central heating of the house.

## **Q. Do I need to have a particular type of roof for Solar installation?**

A. In the UK the best orientation for solar panels is facing due south and tilted at between 30 and 45° from the horizontal. The gains available will reduce as the orientation moves away from due south. A variety of brackets and frames are available for solar systems to suit different roof types (pitched and flat) and different types of roof tiles.

## **Guarantee**

Worcester is proud to offer a guarantee of 10 years on the Greenskies solar panels and a 2 year guarantee on other components providing the panels are registered. It is important that the installer makes a note of the panel serial numbers to be able to successfully register the guarantee.



Please visit **[www.worcesterbosch.co.uk/guarantee](http://www.worcesterbosch.co.uk/guarantee)** to complete the online guarantee registration form.

Greenstore solar compatible unvented hot water cylinders offer a 25 year\* guarantee with a 2 year guarantee on components.



# Total training experience from Land's End to John O'Groats

Worcester has always been committed to setting the industry standard for expert professional training and this is reflected in the scope and content of the courses, venues and options available.

We offer training on our entire range of domestic and commercial heating technologies as well as industry-led courses. All tuition is handled by expert heating specialists, combining classroom theory with, practical hands-on experience. Keep up-to-date with legislation and experience hands-on-training with our new technologies.

To increase your skills, expertise and value in the market place, trust Worcester's unique and proven total training concept.

## Training centres throughout the UK

### **Worcester**

Worcester's award-winning, state-of-the-art Training Academy is an innovative and spacious high tech training arena at our headquarters in Worcester. Facilities include open-plan domestic training areas with life-size single-storey brick buildings. Here installers can get to grips with Greenskies solar thermal systems working with Greenstar gas appliances, clearly demonstrating the importance of system design and operation.

### **Wakefield**

Opened in Summer 2013, the Wakefield Training and Assessment Academy boasts a large gas laboratory which features our entire range of Greenstar gas-fired appliances, a flushing area, wet and dry boilers and a light commercial area with a cascade of Worcester GB162 boilers. There is a solar room with fully working components from our entire Greenskies solar range and a pitched roof for practical training, as well as a large commercial training room.

### **West Thurrock and Clay Cross**

Further academies are located at West Thurrock in Essex and Clay Cross in Derbyshire, both of which offer a comprehensive choice of courses.

## College-linked Learning

As well as offering training at our own centres, Worcester has established close partnerships with many colleges around the UK, equipping them with our latest products.

Worcester has worked closely with leading colleges and independent training centres for more than 20 years – a successful enterprise which in 2007 was enhanced further with the launch of the College Links Learning Scheme.

## Mobile training

We can also bring training to you. We have mobile vehicles fully equipped with operational Greenstar gas-fired boilers, dry strip-down models and even a Greensource air to air heat pump. Our 7.5 tonne mobile oil vehicle is also available for hands-on oil product training and OFTEC assessments.

**Call now for more information 0330 123 0166.**



# Solar product courses

With Worcester's growing product portfolio and an increase in homeowner awareness of renewables, such as solar thermal, it is now more essential than ever that installers and specifiers have knowledge of such technologies.

Our academies enable customers to gain hands-on experience with our entire range of solar products, including working on a simulated roof at height with Greenskies solar thermal panels and installation kits. The advanced solar course covers our range of controls in more detail and looks at swimming pool sizing and East/West splits. It is designed for installers already experienced with installing solar systems.

## Solar courses

**Greenskies solar hot water systems.**

**Greenskies advanced solar** (covers solar controls and pump stations in more detail).

**QCF Level 3 Award.**

## Renewable courses

**Renewable range overview.**



	Solar	Advanced Solar	Renewables Overview
Duration	2 Days	1 Day	1 Day
Cost	Free*	Free*	Free*
<b>Training course covers</b>			
Specification	✓	✓	✓
Installation	✓	✓	✗
Commissioning	✓	✓	✗
Servicing	✓	✗	✗
Maintenance	✓	✗	✗
Product overview	✓	✗	✓
System design	✗	✓	✗
<b>Course locations</b>			
Worcester	✓	✓	✓
Clay Cross	✓	✓	✓
Wakefield	✓	✓	✓
West Thurrock	✓	✓	✓
College Links*	✓	✓	✓
Mobile	✗	✗	✗

\*A holding fee of £65 applies to free courses and is refunded on attendance of the course. If a booking is cancelled more than 10 working days before the course date, the fee will be fully refunded. The fee is non-refundable if a cancellation is made less than 10 working days before the course date.

\*Please contact Worcester Training for specific colleges.

To complement the above courses, Worcester also runs the **Hot Water Systems and Safety course, IDHEE domestic heating design and MCS Made Easy courses.**



# Additional product and industry training courses

The diversity of products in today's heating industry gives you the opportunity to expand your expertise, whilst offering more choice to your customers. Worcester provides comprehensive training from all its academies on its entire range of technologies. Call us on **0330 123 0166** to order a full course training brochure or to book yourself onto a training course, alternatively, you can visit [www.worcester-bosch.co.uk/training](http://www.worcester-bosch.co.uk/training)

## Oil-fired product courses

- Greenstar Danesmoor & Heatslave II high efficiency condensing oil-fired boilers.
- Oil advanced fault finding.
- OFTEC 50.
- OFTEC 101/105e, OFTEC 600a and OFTEC 101/105e/600a.

## Renewable product courses

- Renewables overview.
- Greenskies solar.
- Greenskies advanced solar.
- Introduction to heat pumps.
- Greenstore LECP ground source heat pumps.
- Greensource air to air heat pumps.

## Worcester commercial product courses

- Greenspring CWi47 water heater.
- GB162 overview.
- GB162 domestic.
- GB162 commercial.
- Greenstar Heat Distribution Unit.
- Commercial ACS training and assessment – CODNCO1.

## Bosch commercial product courses

- GB312 & GB402 overview.
- Solar thermal product overview.
- GWPL Gas Absorption Heat Pumps overview.
- CHP overview.
- Commercial controls overview.

## Industry focused courses

- Hot water systems & safety.
- Chemical water treatment.
- Construction skills F-Gas training/assessment certification.
- IDHEE domestic heating design.
- Domestic ACS training and assessment – reassessment. CCN1 + 3 appliances.
- QCF Level 3 Award
  - Air source and ground source heat pumps.
  - Air to water and split air to water heat pumps.
  - Solar thermal.
- MCS Made Easy.
- LPG Changeover.
- WRAS Water Regulations.



# A complete after-sales service

As part of the worldwide Bosch Group, Worcester strives to maintain the highest possible standards of after-sales care.

## Worcester Contact Centre

Should you require support, our award winning Contact Centre team, based at our head office in Worcester, are ready to take your calls. Whatever your query our contact centre operators along with our nationwide team of engineers are ready to help you.

**Tel: 0330 123 9559**

## Opening times

Monday – Friday: 7.00am – 8.00pm

Saturday: 8.00am – 5.00pm

Sunday: 9.00am – 12 noon

Bank Holidays: 8.00am – 4.30pm



## Spares

Genuine replacement parts for all supported Worcester products are readily available from stock, or on a next day delivery basis. Visit [www.worcester-bosch.co.uk/spares](http://www.worcester-bosch.co.uk/spares) to find your local stockist.

## Customer Technical Support

The Worcester Technical Helpline is a dedicated phone line – committed to providing a comprehensive service to complement the brand name and quality of our products. Our experienced team of technical experts provides answers to queries of a technical nature across the entire Worcester range.

## Technical Support

**Tel: 0330 123 3366**

**Fax: 01905 752 741**

**Email: [technical-advice@uk.bosch.com](mailto:technical-advice@uk.bosch.com)**

## Opening times

Monday – Friday: 7.00am – 8.00pm

Saturday: 8.30am – 4.00pm

Bank Holidays: 8.00am – 4.30pm

## ErP Technical Helpline

**Tel: 0330 123 3641**

**Email: [ErP-advice@uk.bosch.com](mailto:ErP-advice@uk.bosch.com)**



# Useful numbers

## Sales

Tel: 0330 123 9669  
sales.mailbox@uk.bosch.com

## Spare Parts

Tel: 0330 123 9779  
spares.mailbox@uk.bosch.com

## Technical Helpline (Pre & Post Sales)

Tel: 0330 123 3366  
technical-advice@uk.bosch.com

## Renewables Technical Helpline

Email: renewable-advice@uk.bosch.com  
or telephone 0330 123 9229

## ErP Technical Helpline

Tel: 0330 123 3641  
ErP-advice@uk.bosch.com

## Training

Tel: 0330 123 0166  
training@uk.bosch.com

## Literature

Email: brochure-request@uk.bosch.com  
or download instantly from our website  
or telephone 0330 123 9119

# Customer Service

## Engineer Appointments

Email: service-appointment@uk.bosch.com  
or telephone 0330 123 9339

## Service Enquiries

Email: service-enquiries@uk.bosch.com  
or telephone 0330 123 9559

## Guarantee Registration

To register your Worcester guarantee,  
please visit our website  
[www.worcester-bosch.co.uk/registration](http://www.worcester-bosch.co.uk/registration),  
download our guarantee  
registration app or  
telephone 0330 123 2552



Guarantee  
app

Calls to 03 numbers cost no more than a national rate call to an 01 or 02 number and must count towards any inclusive minutes in the same way as 01 and 02 calls.  
These rules apply to calls from any type of line, including mobile, BT, other fixed phone line or payphone. Calls from mobiles and some other networks may vary.  
Calls to and from Bosch Thermotechnology Ltd may be recorded for training and quality assurance purposes.

# worcester-bosch.co.uk



In partnership with



Worcester, Bosch Group is a brand name of Bosch Thermotechnology Ltd.

This leaflet is accurate at the date of printing, but may be superseded and should be disregarded if specification and/or appearances are changed in the interest of continued improvement. The statutory rights of the consumer are not affected. Apple is a trademark of Apple Inc., registered in the U.S. and other countries. App Store is a service mark of Apple Inc. Google Play and Android are trademarks of Google Inc.



Part No. 8 716 110 080 K 11/15



BBT3659



Worcester, Bosch Group,  
Cotswold Way, Warndon,  
Worcester, WR4 9SW