



Greenstar floor standing gas-fired condensing combi and regular boiler series

**NEW
Design
Features**



Worcester and you. Making a difference.

As part of the Bosch Group, Worcester products are designed and manufactured to provide customers with the highest levels of quality and reliability which are synonymous with the Bosch name throughout the world.

As part of Europe's largest supplier of heating products, Worcester, Bosch Group has the UK-based resources and support capability to offer you the value-added solutions you deserve. Worcester employs a nationwide network of Service Engineers and technically trained Field Sales Managers

supported by an experienced technical services team which is able to provide comprehensive support and advice from designing system layouts through to installation.

Worcester is dedicated to providing energy efficient gas- and oil-fired condensing boilers, as well as an extensive range of renewable technologies. All of our products have been developed and introduced with the aim of helping the UK to achieve the Government's efficiency targets.



BOSCH
Invented for life



The reception and main entrance at our Worcester headquarters

“At Worcester we recognise the vital role you play in the specification and installation of energy efficient appliances in homes across the UK. We will continue to invest in our products, people, facilities and added value services to ensure you have all you require in order to deliver only the best solutions to your customers’ requirements.”

Carl Arntzen,
Managing Director,
Bosch Thermotechnology Ltd.

Contents

Page

Key features of the range	4 - 5
Greenstar Highflow CDi	
Features and benefits	6 - 7
Inside story	8 - 9
Controls	10 - 11
Wave – smart heating control	12 - 13
Greenstar FS CDi Regular	
Features and benefits	14 - 15
Inside story	16 - 17
Greenstore unvented cylinder series	18
Features and benefits	19
ErP easy as ABC	20 - 21
Greenstar Highflow CDi	
Site preparations and guidance	22 - 24
Greenstar FS CDi Regular	
Site preparations and guidance	25 - 26
Installation requirements	27 - 29
NEW Greenstar System Filter	30 - 31
Condensate pipework	32 - 33
Horizontal and vertical flue terminal positioning	34 - 35
Horizontal fluing options	36 -38
Vertical fluing options	39 - 40
Greenstar FS CDi Regular series flexible flue system for chimney installations	41 - 42
Plume management positioning and system options	43 - 46
Accessories	47 - 49
Training	50 - 52
After-sales	53



Key features of the range



Outstanding performance

The Greenstar floor standing series is a well-established range of energy-saving, floor standing, gas-fired combi boilers which incorporate a host of features that benefit the installer, the end user and the environment.

Winner of Which? Best Buy awards in 2010, 2011, 2012, 2013, 2014 and 2015

For six consecutive years, in a survey of Which? members, the Worcester Greenstar gas-fired condensing boiler range has been presented with Best Buy awards. In the latest survey, no other manufacturer scored higher for reliability.

NEW features

Several updates have been made to the Greenstar Highflow CDi and FS CDi Regular both in response to installer feedback and to ensure compliance with new legislation, these updates include:

- An air intake test point which has been added, making commissioning and service checks easier and quicker
- A slimmer design of condensate trap, to meet the latest EU testing standards and provides easier access for servicing.

Ease of installation

The Greenstar floor standing boilers have been designed to make installation as straight forward as possible. The appliance is supplied with a floor mounted pre-plumbing jig which enables gas and water services to be installed before connection to the boiler is made. The boiler has a wheel-in tray which enables the appliance to be easily slid into place once the pipe connections have been made. This feature also makes maintenance and servicing easier.

Peace of mind

Worcester Greenstar floor standing boilers benefit from a full 5 year guarantee* on parts and labour and a 10 year guarantee* on the primary heat exchanger*.



On all Greenstar floor standing appliances*



On the primary heat exchanger*



The clean 'skin' design of Worcester Greenstar boilers is incorporated into the Greenstar Highflow CDi range.

The Greenstar floor standing boiler series at a glance

		Greenstar Highflow 440CDi combi	Greenstar Highflow 550CDi combi	Greenstar FS 30CDi Regular	Greenstar FS 42CDi Regular
Part no.	NG	7 731 600 098	7 731 600 100	7 731 600 102	7 731 600 104
	LPG	7 731 600 099	7 731 600 101	7 731 600 103	7 731 600 105
Output kW to central heating	Min	7.4kW	9.7kW	7.7kW	9.6kW
	Max	29.2kW	30.6kW	30kW	40.8kW
Flow rate		20l/min*	25l/min*	-	-
CH temperature control		✓	✓	✓	✓
DHW temperature control		✓	✓	-	-
Modulating control		✓	✓	✓	✓
Natural gas		✓	✓	✓	✓
LPG boiler		✓	✓	✓	✓
Electronic ignition		✓	✓	✓	✓

*Provided adequate mains water pressure and flow is available – see page 28 for further details.

Greenstar Highflow CDi

Features and benefits

The unique Worcester Greenstar Highflow CDi floor standing combi boilers form part of the CDi classic range. These boilers have been specially developed for larger two bathroom properties where there is a greater requirement for heating and hot water.

Hot water performance

Greenstar Highflow CDi combi boilers are renowned for their industry-leading hot water flow rates of up to 25 litres a minute. This, combined with rapid re-heat times makes them especially suitable for larger properties with multiple hot water outlets. They are able to deliver comparable flow rates to systems with an unvented mains cylinder without the need for a separate storage tank. As a result, baths fill more quickly and longer showers can be enjoyed, whilst the separate plated heat exchanger and thermal store ensures that hot water is delivered instantly on demand.

Controls

A choice of optional controls is available with Greenstar Highflow CDi boilers to enable your customers to select the type of control which best suits their individual requirements. The recommended choice ranges from a simple-to-operate digital programmer to sophisticated wireless programmers, room thermostats and intelligent controls including the Wave smart control. For more on these, see pages 10-13.

Installation benefits

- Familiar design so no surprises during installation
- Tried and tested heat exchanger, as used in the popular wall-mounted Greenstar CDi Classic series, provides long and reliable service
- Ideal solution for properties with high hot water demand and multiple hot water outlets
- Uses standard Worcester multi-directional fluing options for ease of installation in a wide range of situations
- Supplied as standard with 12 litre expansion vessel, 3bar pressure relief valve, pressure gauge and automatic air vent
- Built-in condensate pump increases siting possibilities and helps to reduce the risk of frozen condensate
- Pump seizure protection reduces the risk of call-backs
- Easy to site with dimensions comparable to standard 'white goods' appliances.

Environmental benefits

- ErP 'A' rated for space heating
- SEDBUK A rating of up to 89.2% (2009 rating)
- WB5 heat exchanger delivers high efficiency and reliability
- Low electrical consumption when in standby mode
- NOx emissions of 23mg/kWh – achieves 3 credits under the Code for Sustainable Homes
- All boilers and components are 100% recyclable, achieving Worcester's zero waste to landfill objective.



For more information on ErP, see pages 20-21.

Fluing options

The Greenstar Highflow CDi range has a full range of Condensfit II™ flue options in both 60/100mm and 80/125mm diameters and includes a plume deflector as standard. This versatile flue system can be run horizontally or vertically.

Backed by Worcester quality

Every Greenstar Highflow CDi boiler is operationally tested before it leaves the factory as part of Worcester's rigorous quality control procedure. When you install a Worcester boiler, you can rest assured that your customer is receiving the best quality components and highest levels of workmanship.

WB5 heat exchanger

The Worcester WB5 heat exchanger has been designed to optimise clean burning combustion over an extra-large surface area. Each heat exchanger is factory-set and 100% tested so, as long as the gas inlet pressure is correct, commissioning is straightforward. The heat exchanger requires minimal servicing which means fewer spare parts during its lifetime. The heat exchanger can be cleaned in situ via an inspection hatch, again saving time during service.



WB5 Heat Exchanger



On the primary heat exchanger*



End user benefits

- Significant reductions in energy costs thanks to latest condensing technology and high efficiency heat exchanger
- Exceptional flow rates even with multiple hot water outlets
- Quick re-heat times
- Hot water at mains pressure without the need for a pump
- Frees up space by not requiring a hot water cylinder
- Modulating central heating and hot water outputs, combined with advanced Worcester controls, enable comfortable temperatures to be set independently of each other
- Full 5 year guarantee on parts and labour*
- 10 year guarantee on Worcester primary heat exchanger*
- Part of the Which? Best Buy range for gas-fired condensing boilers.



The Greenstar Highflow CDi boiler is recommended by the Energy Saving Trust (EST). The Energy Saving Trust is a non-profit organisation that provides free and impartial advice on how to save energy.



*Terms and conditions apply.

Inside story –Greenstar Highflow CDi condensing combi boiler series

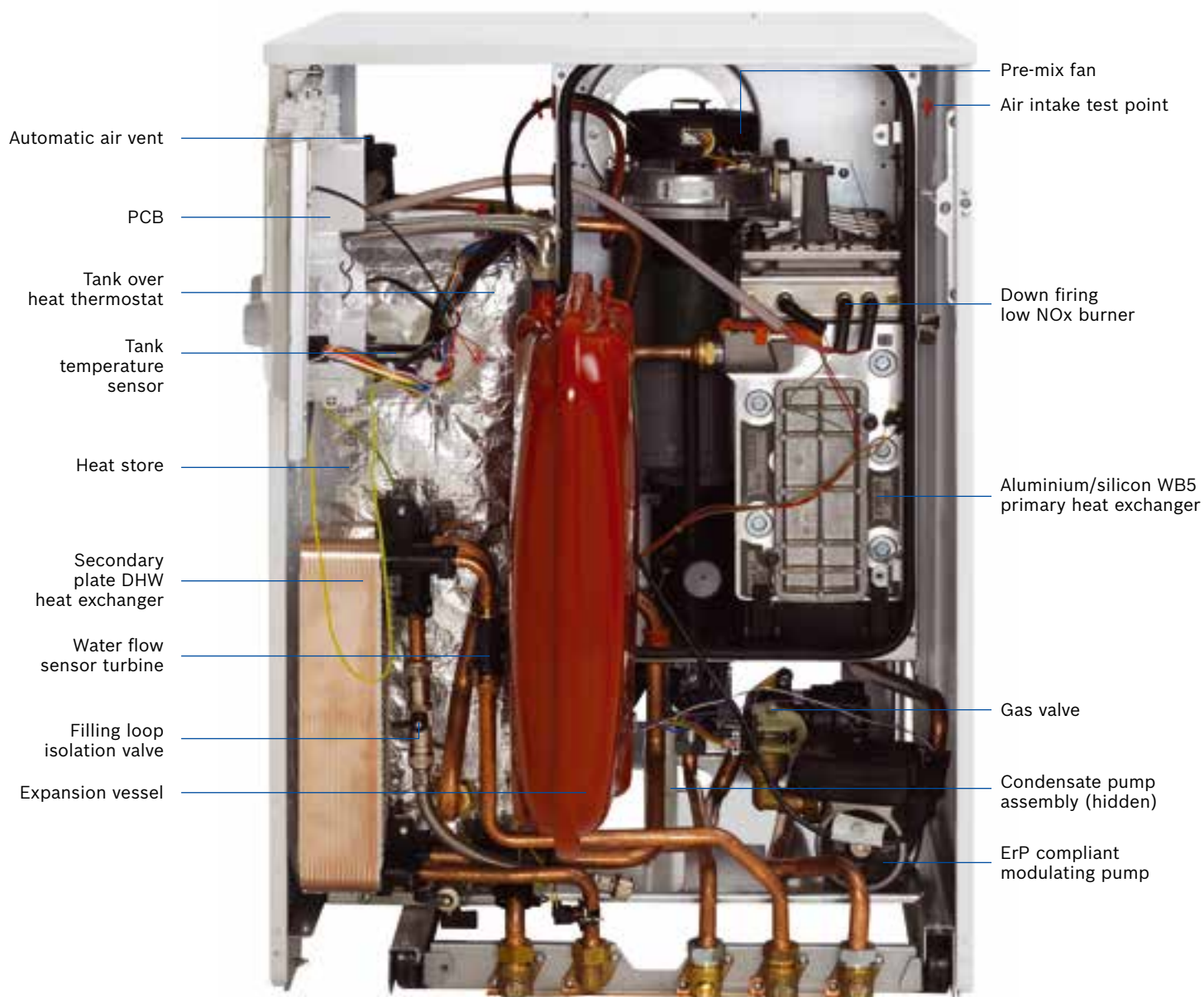

Automatic air vent
PCB
Tank over heat thermostat
Tank temperature sensor
Heat store
Secondary plate DHW heat exchanger
Water flow sensor turbine
Filling loop isolation valve
Expansion vessel

Pre-mix fan
Air intake test point
Down firing low NOx burner
Aluminium/silicon WB5 primary heat exchanger
Gas valve
Condensate pump assembly (hidden)
ErP compliant modulating pump

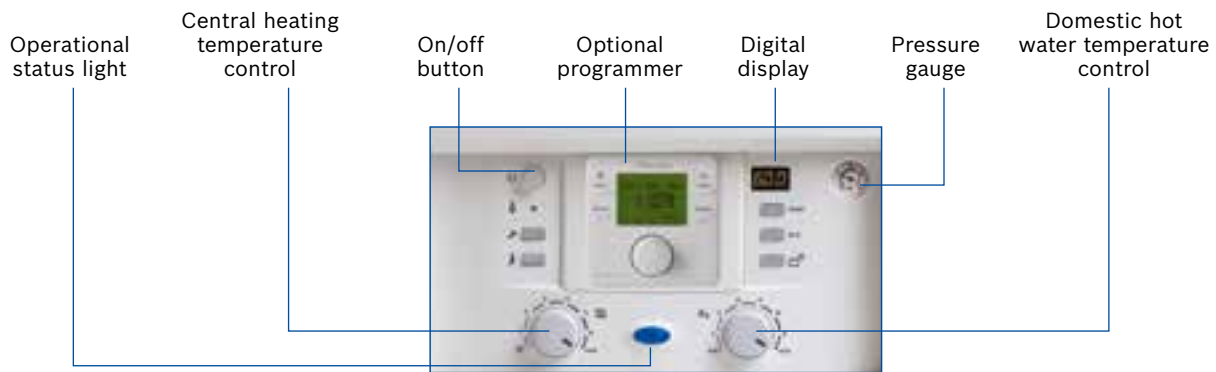

Greenstar Highflow CDi fascia with optional Comfort I RF plug-in twin channel programmer fitted

Technical data

Boiler	Greenstar Highflow 440CDi	Greenstar Highflow 550CDi
Height	850mm	850mm
Width	600mm	600mm
Depth	600mm*	600mm*
Weight – dry	112kg	112kg
Seasonal space heating energy efficiency class	A / 92%	A / 92%
ErP Water heating energy efficiency class (declared load profile XL)	B	B
2009 SEDBUK efficiency – natural gas	89.2%	89.2%
Heating flow / return connections	22mm compression	22mm compression
Hot / cold water connections	22mm compression	22mm compression
Pressure relief valve	15mm dia.	15mm dia.
Condensate connection	22mm plastic pipe	22mm plastic pipe
Gas connection	22mm compression	22mm compression
Primary water content	51 litres	51 litres
Minimum domestic inlet pressure for max. DHW flow rate	1.5bar	1.7bar
Minimum domestic inlet pressure to operate the appliance	0.5bar	0.5bar
Maximum domestic inlet pressure	10bar	10bar
DHW flow rate	20 l/min	25 l/min
Output to central heating	7.4 - 29.2kW	9.7 - 30.6kW
Floor mounted pre-plumbing jig	✓	✓
Filling link	✓	✓
Plug-in timer	✓ (optional)	✓ (optional)
Condensate disposal pump	✓	✓
Fault diagnostic display	Digital	Digital
Maximum vertical flue (100mm dia.) inc. terminal	6,400mm	6,400mm
Maximum vertical flue (125mm dia.) inc. terminal	15,000mm	15,000mm
Maximum horizontal flue (100mm dia.)	4,000mm	4,000mm
Maximum horizontal flue (125mm dia.)	13,000mm	13,000mm
NOx classification – natural gas	23mg/kWh	23mg/kWh
NOx class	5	5
Noise output level	53dB(A)	52dB(A)

*630mm to front of flap.

Controls – Greenstar Highflow CDi

5 year guarantee

When purchased and installed at the same time, the guarantee period for a Worcester control will match that of a Greenstar gas-fired boiler*.



NEW Greenstar Sense controls



Sense I – Intelligent room thermostat – Part no. 7 738 110 054

- ✔ Load compensation feature for increased efficiency
- ✔ Boiler output automatically adjusted to precisely meet the heat demand of the property at maximum efficiency
- ✔ Maximises the condensing boiler's operation
- ✔ Ideal when replacing an existing, less efficient wired room thermostat.



Sense II – Weather compensation controller – Part no. 7 738 111 064

- ✔ Intelligently interacts with the boiler to provide weather compensation via a wired outdoor sensor
- ✔ Solar thermal optimisation in conjunction with MS100 solar module
- ✔ Displays the amount of energy recovered from a solar system
- ✔ Service reminder function
- ✔ Enables an A+ ErP system efficiency to be achieved when installed with any Greenstar i, Si or CDi Compact boiler.



NEW Greenstar Comfort controls



Comfort plug-in twin channel programmer – Part no. 7 733 600 003

- ✔ Simple menu navigation
- ✔ 7-day time control for heating and hot water
- ✔ Heating programme visualisation bar.



Comfort I RF wireless room thermostat and plug-in twin channel programmer – Part no. 7 733 600 001

- ✔ All the features of Comfort PLUS...
- ✔ Enhanced load compensation for increased efficiency
- ✔ No wiring required
- ✔ Extremely reliable RF signal.



Comfort II RF wireless programmable room thermostat and plug-in RF receiver – Part no. 7 733 600 002

- ✔ All the features of Comfort and Comfort I PLUS...
- ✔ 6 adjustable heating temperatures per day
- ✔ Set programme at the room thermostat
- ✔ Remote access to boiler diagnostic codes.



Controls at a glance

Control option	TYPE				MOUNT		TIME CONTROL				TEMPERATURE CONTROL				CONNECTION TYPE			EFFICIENCY		
	Mechanical	Digital	Intelligent	Internet	Fascia mounted	Wall mounted	Central heating	Hot water	24 hour	7 day	Auto switch – BST/GMT	Room thermostat	Programmable room thermostat	Optimum start	Boiler flow temp compensation	Plug-in	Radio frequency	Hard wired	ErP Class	Efficiency benefit
Comfort		✓			✓		✓	✓		✓	✓					✓			-	-
Comfort I RF			✓		✓	✓	✓			✓	✓	✓			✓		✓		V	3%
Comfort II RF			✓			✓	✓	✓		✓	✓	✓		✓		✓			V	3%
Sense I*			✓			✓						✓			✓			✓	V	3%
Sense II			✓		✓	✓	✓			✓	✓	✓	✓	✓	✓	✓		✓	VI [^]	4% [^]
Wave			✓	✓		✓	✓			✓	✓	✓	✓	✓			✓		VI	4%

*Must be used with an external proprietary 230V timer. ^When installed as a room thermostat.

Worcester Wave – smart control for heating and hot water

The Wave is the first of a new generation of Worcester controls.

The Wave is a smart, internet-connected programmable control for central heating and hot water which can be operated using a smart device.

The Wave's innovative programming enables it to have an 'intelligent conversation' with the boiler and take advantage of advanced control features such as weather and load compensation.



Enhanced energy efficiency

In the ErP Directive, smart controls like the Wave is a Class VI control, adding 4%* to the overall system efficiency for heating, resulting in lower fuel bills. This increases the ErP rating to 'A+' for the Greenstar i, Si Compact and CDi Compact on heating.

The Wave's energy efficiency features include:

- ✔ Charts of heating and hot water usage so the homeowner can easily identify where potential savings could be made.
- ✔ When the room temperature is turned down a leaf symbol will appear to indicate additional savings are being made.
- ✔ Load and weather compensation via the Internet so no outdoor sensor is required. This allows the boiler to modulate its performance to meet the needs of the household with optimum efficiency.

Adapting to the homeowner's needs

Each Wave unit is supplied with a pre-set programme that can then be easily modified to suit the user's requirements.

The Wave's advanced user features include:

- ✔ 'Pairing' with up to eight devices, automatically sensing when people are at home.
- ✔ Sensing to an individual device can be turned off if required.
- ✔ The Wave will remember preferred programme settings to make these easily available and features a 'holiday programme', requiring just a start and finish date.
- ✔ Unlike most other smart heating controls, the Wave can also programme the hot water settings, providing additional energy savings and comfort.
- ✔ For security and peace of mind, all of the Wave's data is owned by the user, ensuring no information is shared with other parties.

Wave compatible devices:**

Apple® devices running iOS 5.1 and higher

Android™ devices running 2.2, 2.3 or 4.0 and higher



Quick to install

The Wave is quick and easy to install:

- ✔ Only requires a 2-core wire connection between the control and the boiler.
- ✔ All other connections are via the Wi-Fi network.
- ✔ The Wave does not need an external wired sensor unlike standard weather compensation controls.
- ✔ The Wave uses online data which significantly reduces installation time and cost to the end user.

As with all room heating controls the Wave should be sited where it can monitor the overall temperature of the property.



Compatibility with Worcester Greenstar boilers

Ideal for homes and small businesses, the Wave is compatible with all current Worcester Greenstar gas-fired combination and system* boilers. It can also be retrofitted for use with previous Worcester EMS-bus appliances.

All you need is:

- ✔ Worcester Wave control
- ✔ Worcester compatible boiler*
- ✔ Wi-Fi enabled broadband router – 802.11 b/g
- ✔ Wave app on a compatible Apple® or Android™ device.

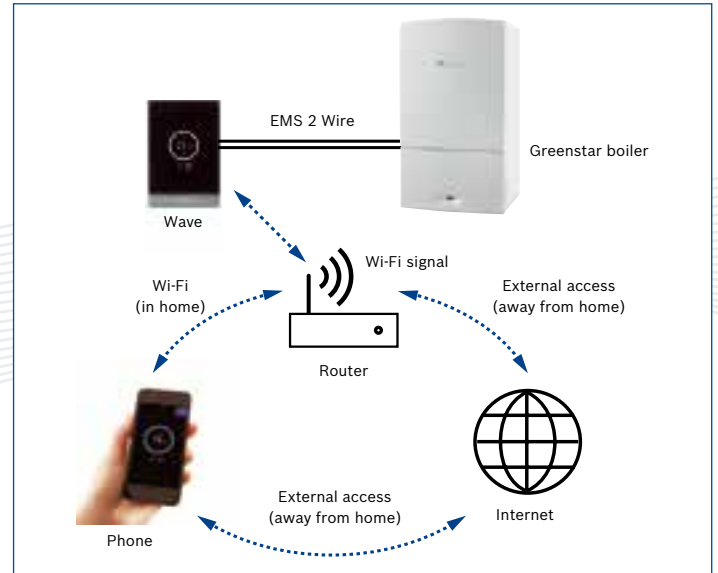

Simple to use, providing an easy handover

The Wave's intuitive and modern design ensures it is very simple to operate using either its in-built touchscreen or via the Wave app.

- ✔ Users simply download the Wave app to their compatible device to take control of their heating system from anywhere in the world where an internet connection is available.
- ✔ There are no subscription fees or chargeable app add-ons, therefore updates to the app software are completely free of charge.
- ✔ An installation and operating manual is provided with each control and there are a number of helpful videos to provide further detail on specific functions.
- ✔ Should the Wave temporarily lose the internet connection, it will continue to operate as an intelligent heating and hot water control simply by using the last saved programme settings.



Part number	Description
7 716 192 072	Wave

Greenstar FS CDi Regular

Features and benefits

The Greenstar FS CDi Regular is capable of operating on both open vent and sealed primary water systems. Two or more Greenstar FS CDi Regular boilers can be linked together to cater for small commercial applications. Using the new flexible flue system the Greenstar FS CDi is an ideal replacement for a floor standing boiler located near a fireplace and using a chimney liner to flue.

The complete system solution

Greenstar regular boilers are ideal for use with our comprehensive range of Greenstore single and twin-coil unvented hot water cylinders, providing fast re-heat times with excellent heat retention properties. The combination of a Greenstar regular boiler and a Greenstore cylinder delivers hot water to the taps at mains pressure, filling baths quickly and ensuring that showers are powerful and invigorating. For more information on our Greenstore cylinder range, see pages 18-19.

Solar thermal heating

When used in conjunction with a Greenstore twin-coil cylinder, Greenstar regular boilers can be fully integrated with Greenskies solar water heating systems, which have the potential to provide up to 60%** of annual hot water requirements. So even if solar water heating is not required at the time of installation, installing a twin-coil cylinder will enable the system to be upgraded easily in the future.

Installation benefits

- Pre-fabricated pipe connections supplied
- Roll-in boiler minimises the risk of damaging floors
- Multi-directional Condensfit II™ fluing is compatible with plume management
- Fault-finding diagnostics – saves time
- Rigid 22mm gas connection – no pre-forming of gas supply
- Built-in frost protection – money saving, economical protection.

Environmental benefits

- ErP 'A' rated for space heating
- SEDBUK A rating of 88.8% and above (2009 value)
- Low electrical consumption in standby mode
- WB5 aluminium-silicon heat exchanger delivers high efficiency and reliability
- Anti-cycle control.



For more information on ErP, see pages 20-21.

Fluing options

The Greenstar FS CDi Regular series features 2 different sizes of multi-directional RSF flue systems, 100mm or 125mm dia.

The flue can be run horizontally or vertically with additional 90° or 45° in-line bends allowing changes of route or direction.

In addition an 80mm flexible flue system is available which utilises an existing chimney in the building to route the flue terminating on top of the chimney.

More details on our flue and plume management systems are shown on pages 34-46.

WB5 heat exchanger

The Worcester WB5 heat exchanger has been designed to optimise clean burning combustion over an extra-large surface area. Each heat exchanger is factory-set and 100% tested so, as long as the gas inlet pressure is correct, commissioning is straightforward. The heat exchanger requires minimal servicing which means fewer spare parts during its lifetime. The heat exchanger can be cleaned in situ via an inspection hatch, again saving time during service.



WB5 Heat Exchanger

On the primary heat exchanger*



End user benefits

- Bosch renowned quality and reliability
- Built-in boiler frost protection
- Boiler protection plans available for both new and out-of-guarantee Worcester Greenstar boilers
- Full 5 year guarantee on parts and labour*
- 10 year guarantee on Worcester primary heat exchanger*
- Part of the Which? Best Buy range for gas-fired condensing boilers.



The Greenstar FS CDi Regular boiler is recommended by the Energy Saving Trust (EST). The Energy Saving Trust is a non-profit organisation that provides free and impartial advice on how to save energy.



*Terms and conditions apply.

Inside story – the Greenstar FS CDi Regular condensing boiler

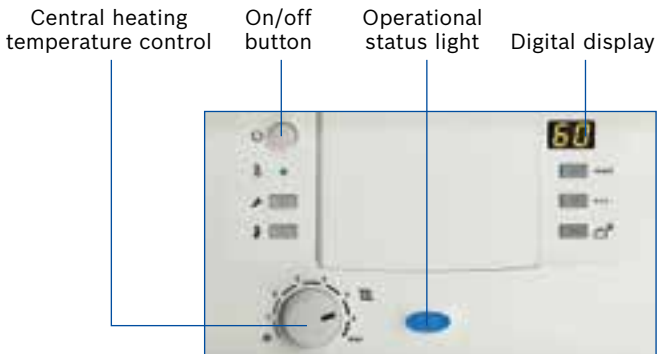
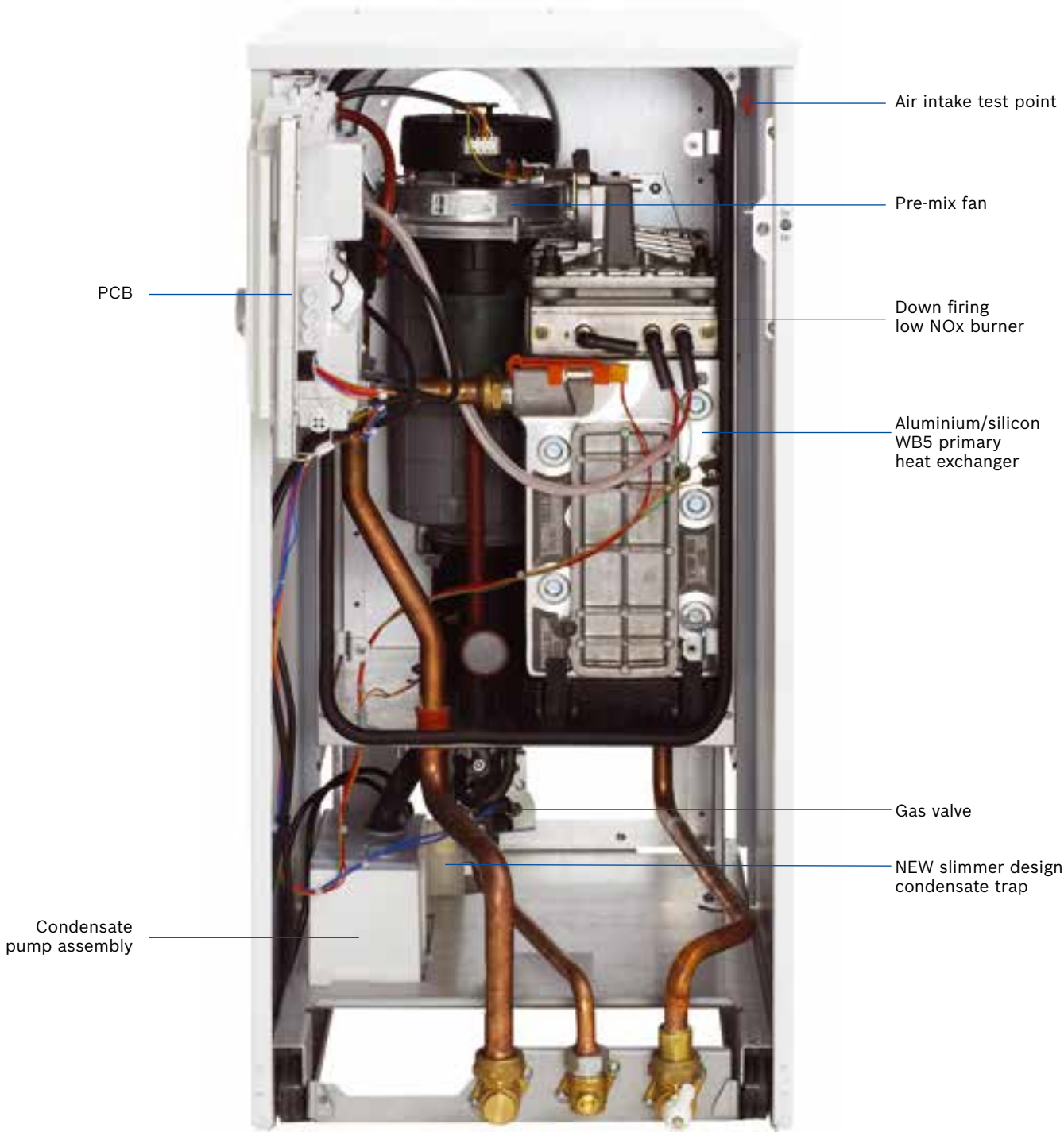

Technical data

Boiler	FS 30CDi Regular	FS 42CDi Regular
Height	850mm	850mm
Width	400mm	400mm
Depth	600mm	600mm
Weight - dry	55.1kg	55.1kg
Seasonal space heating energy efficiency class	A / 92%	A / 92%
2009 SEDBUK efficiency - natural gas	88.9%	88.8%
Heating flow / return connections	28mm compression	28mm compression
Condensate connection	22mm plastic pipe	22mm plastic pipe
Gas connection	22mm compression	22mm compression
Maximum flow temperature	88°C	88°C
Output to central heating (natural gas)	7.7 - 30kW	9.6 - 40.8kW
Fault diagnostic display	✓	✓
Flow and return pipes supplied to allow pipes behind installation	✓	✓
Maximum vertical flue (100mm dia.) inc. terminal	6,400mm	6,400mm
Maximum vertical flue (125mm dia.) inc. terminal	15,000mm	15,000mm
Maximum horizontal flue (100mm dia.)	4,000mm	4,000mm
Maximum horizontal flue (125mm dia.)	13,000mm	13,000mm
NOx classification - natural gas	23mg/kWh	29mg/kWh
NOx class	5	5
Noise (sound power level)	53dB(A)	54dB(A)
Ingress protection (IP)	X4D	X4D



Efficient hot water storage solutions from Worcester



Worcester is proud to offer the Greenstore range of high efficiency unvented cylinders which offer excellent hot water comfort for properties with a stored DHW supply.

Designed by Worcester. Developed by Bosch

Worcester Greenstore cylinders, which are manufactured by Bosch, are available in both an unvented (SC) and solar compatible unvented (TC) option. The Greenstore unvented SC is available in seven different models ranging from SC-90 to SC-300. The Greenstore solar compatible cylinders are available in five options ranging from TC-150 to TC-300.

The Worcester Greenstore cylinder series is fully compatible with a wide range of non-Worcester boilers and solar panels, although to achieve the optimum system solution it is recommended that a Greenstore cylinder is coupled with either a Greenstar high efficiency boiler or Greenskies solar panel installation.

Why choose an unvented cylinder?

- High performance due to unrestricted mains pressure at hot water outlets
- A perfect replacement for low efficiency copper vented cylinder installations
- Stainless steel, delivering durability
- Siting flexibility – no need to locate the cylinder directly underneath a cold water storage cistern.





The Greenstore unvented series

The Greenstore unvented SC cylinder benefits consumers who do not require solar compatibility, but are looking for a cylinder which offers high levels of insulation, excellent flow rate and outstanding re-heat performance. The Greenstore unvented range is also ideal for consumers who require a smaller capacity of hot water storage, with the unvented series being available in SC-90 and SC-120 variants.



The Greenstore unvented solar compatible series

All of the models in the solar compatible Twin Coil (TC) cylinder series feature high levels of insulation and dedicated solar volumes in compliance with current Building Regulations, SAP 2012 and the Microgeneration Certification Scheme (MCS). Worcester's Greenstore solar compatible stainless steel cylinders have been specifically designed for use with solar heating installations, combined with boiler back-up.



Greenstore unvented cylinder series at a glance

Unvented	Greenstore SC-90 Cylinder	Greenstore SC-120 Cylinder	Greenstore SC-150 Cylinder	Greenstore SC-180 Cylinder	Greenstore SC-210 Cylinder	Greenstore SC-250 Cylinder	Greenstore SC-300 Cylinder
Part no.	7 716 842 027	7 716 842 028	7 716 842 029	7 716 842 030	7 716 842 031	7 716 842 032	7 716 842 033
Height	835mm	1,035mm	1,285mm	1,490mm	1,665mm	1,860mm	2,155mm
Diameter	570mm	570mm	570mm	570mm	570mm	570mm	570mm
Weight – dry	26kg	31kg	36kg	40kg	44kg	48kg	54kg
Heat exchanger surface area	0.657m ²	0.657m ²	0.657m ²	0.657m ²	0.845m ²	0.845m ²	0.845m ²
Volume domestic hot water	93 litres	123 litres	161 litres	191 litres	216 litres	246 litres	292 litres
Standing heat loss – 24hr	1.008kWh /24hrs	1.296kWh /24hrs	1.632kWh /24hrs	1.824kWh /24hrs	1.944kWh /24hrs	2.136kWh /24hrs	2.304kWh /24hrs
ErP energy efficiency class/ Standing heat loss	B / 42W	C / 54W	C / 68W	C / 76W	C / 81W	C / 89W	C / 96W

Solar compatible	Greenstore TC-150 Cylinder	Greenstore TC-180 Cylinder	Greenstore TC-210 Cylinder	Greenstore TC-250 Cylinder	Greenstore TC-300 Cylinder
Part no.	7716 842 040	7 716 842 041	7 716 842 042	7 716 842 043	7 716 842 044
Height	1,285mm	1,490mm	1,665mm	1,860mm	2,155mm
Diameter	570mm	570mm	570mm	570mm	570mm
Weight – dry	41kg	45kg	50kg	54kg	60kg
Heat exchanger surface area	0.657m ²	0.657m ²	0.845m ²	0.845m ²	0.845m ²
Volume domestic hot water	157 litres	187 litres	211 litres	241 litres	287 litres
Standing heat loss – 24hr	1.632kWh /24hrs	1.824kWh /24hrs	1.944kWh /24hrs	2.136kWh /24hrs	2.304kWh /24hrs
Dedicated solar volume	65 litres	65 litres	105 litres	115 litres	115 litres
ErP energy efficiency class/ Standing heat loss	C / 68W	C / 76W	C / 81W	C / 89W	C / 96W

ErP easy as ABC

What is ErP?

The ErP Directive, which is a new regulation set by the European Union, is designed to drive improvements in the efficiency and performance of heating and hot water products. Its purpose is to ensure that end users are aware of the level of energy efficiency inherent within their appliances. As such, the Directive will help improve the overall efficiency of the housing stock, while enabling homeowners to reduce their energy bills. The ErP regulations cover boilers, combination boilers, heat pumps and other heating appliances up to 400kW.



What is Energy Labelling?

The Energy Labelling involves a label which we are familiar with today on washing machines and televisions at the point of sale. The Energy Labelling regulations introduce Europe-wide energy labelling requirements for boilers, combination boilers, water heaters and other heating products up to 70kW and hot water cylinders under 500 litres.

How will the labelling scheme work?

The new Energy Labelling Directive will introduce new efficiency classes from A++ to G alongside the existing SEDBUK rating for boilers in the domestic and light commercial sectors.

Most condensing boilers will fall within the A band, which requires them to achieve more than 90% seasonal efficiency, while renewable technologies such as heat pumps will likely be in the A+ or A++ bands (depending on flow temperature).

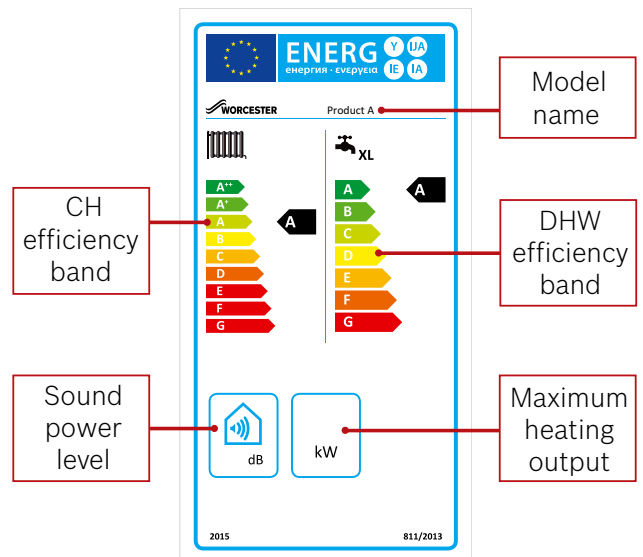

What about systems that contain different products?

In these circumstances, there is a responsibility to provide a package label when combining a heating appliance with a temperature control and/or solar device, cylinder or a supplementary heating appliance (for example, a two-boiler cascade with a combined total output of under 70kW).

The person who puts that package together will need to produce a package document known as a fiche (data table) and label that provides the combined energy efficiency rating rather than ratings of each individual component.

For example, this could be the merchant's responsibility if they supply a complete package under one part number or the installer if the items are bought individually under separate part numbers.

In either circumstance, Worcester will provide an online tool that makes calculating the overall package efficiency of a Worcester system effortless.

What about controls?

The ErP Directive covers all products that consume energy, such as boilers, heat pumps, solar thermal etc. It also includes controls, which are defined using 'classes'. These run from Class I (a simple on/off room stat) through to Class VIII (multi-sensor room control for use with modulating heating appliances).

Each control class equates to a certain percentage uplift in system efficiency e.g. a class VI weather compensating control and room thermostat will add 4% efficiency to the heating system.



ErP easy as ABC with Worcester

The Energy Labelling obligation under the Energy Related Products (ErP) Directive came into force on the 26th September 2015. Worcester has a number of measures in place to support you including:

- ✔ An **online label generator** which creates product and heating system labels
- ✔ ErP will be covered in all **Worcester training courses**
- ✔ **ErP experts** – our technical and customer support teams can answer all your questions.

ErP Technical Support: **0330 123 3641**
Email: **ErP-advice@uk.bosch.com**



Site preparations and guidance – Greenstar Highflow CDi

All combi boilers require less installation time than a conventional boiler, for these reasons:

- Highly versatile multi-directional fluing system
- Combined ignition and control board means less connections
- Supplied with built-in filling link
- Optional plug-in timers
- Built-in boiler frost protection
- Supplied with roll-on bracket and floor mounted installation frame.

Siting of appliance

The appliances are only to be installed internally within a property, at a suitable location onto a fixed, rigid surface, that is at least the same size as the appliance and is capable of supporting its weight.

Mounting on a combustible surface

The appliances may be installed into an airing cupboard if required. Use a non-combustible perforated material (max. hole sizes of 13mm) to separate the boiler from the airing space. See section “Boiler location”.

Installation and service clearances

The minimum clearances shown below should be allowed for installation and servicing. Compartment ventilation would only be required at these clearances.

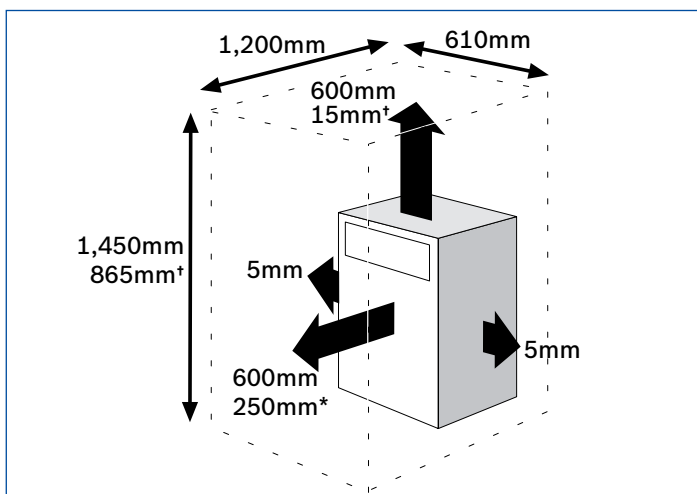

Installation and service clearances for Greenstar Highflow CDi

*Space required for unvented areas with a removable door or panel

†Clearances for servicing

Compartment installation

Compartments: Follow the requirements of BS 6798 and BS 5440 Part 2 and note:

- Minimum clearances must be maintained
- An access door is required to install, service and maintain the boiler and any ancillary equipment
- If fitting the boiler into an airing cupboard use a non-combustible perforated material (maximum hole sizes of 13mm) to separate the boiler from the airing space.

Boiler location

The appliance may be installed in any room, although particular attention is drawn to the requirements of the IEE regulations applicable, and in Scotland the electrical provisions with respect to installation in a room containing a bath or shower.

1. The room in which the appliance is installed does not require a dedicated air vent.
2. If the appliance is installed in a cupboard or compartment with dimensions that allow the following minimum clearances, then no ventilation is required:

Compartment installation	
Position of appliance	Minimum unvented clearance (to removable door)
In front	75mm*
Right side	100mm
Left side	100mm
Above flue elbow/casing	50mm

*75mm from an opening door. 600mm is required for servicing

Ventilation-free compartment installation – minimum clearances

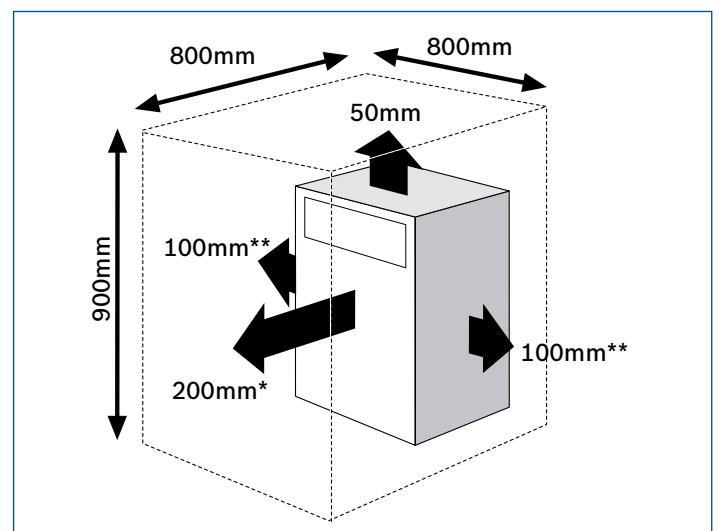

*Space required for unvented areas with a removable door or panel.

**This space can be reduced to 50mm for one side only as long as both the side clearances add up to the total of both the side measurements shown or more.

Airing cupboard clearances - minimum clearances

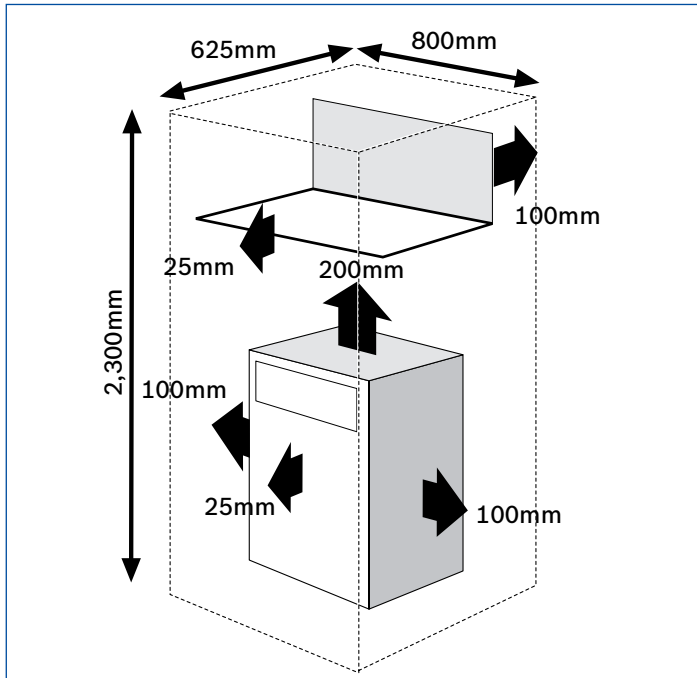

Venting compartments

If the clearances are less than those stated for the options above then ventilation must be provided as described in BS 5440.

A minimum of 2 air vents (A) must be fitted, one at low level and another at high level onto the same wall using the same air for circulation, see diagram below.

Minimum free air required for venting:

- For air directly from outside:
 - Greenstar Highflow 440CDi 155cm² per vent
 - Greenstar Highflow 550CDi 220cm² per vent
- For air from internal space/room:
 - Greenstar Highflow 440CDi 310cm² per vent
 - Greenstar Highflow 550CDi 440cm² per vent

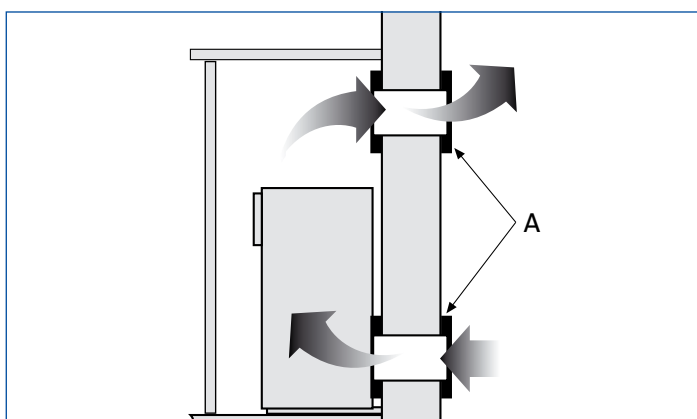

Important: bathroom locations and clearances

- The boiler must not be installed in Zone 1
- Any switch or appliance control using mains electricity must not be within reach of a person using the bath or shower
- Electrical switches (other than pull cords), fused spurs and socket outlets must not be situated in the bathroom
- A boiler fitted with a Sense II controller may only be installed outside the shaded area. A boiler with any other timer fitted (or blanking panel for an optional programmer) can be installed in zone 2.
- Additional Residual Current Device (RCD) protection may be required.

Refer to the latest IET (IEE) wiring regulations.

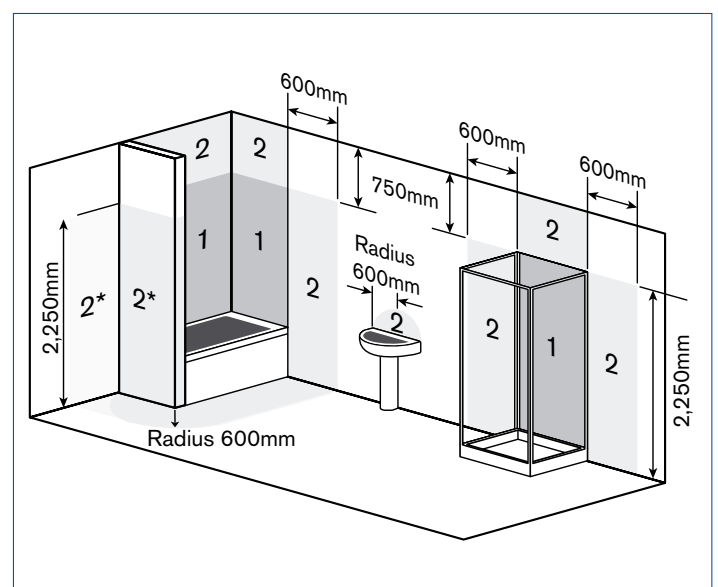
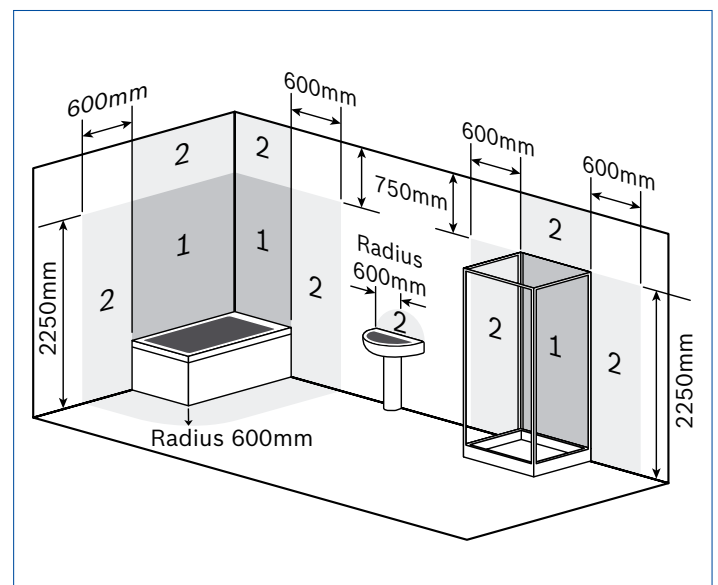

*Without the end wall, zone 2 must extend 600mm from the bath.

Site preparation/portability

Greenstar Highflow CDi appliances are supplied with a floor mounted pre-plumbing jig. The jig enables all gas and water services to be pre-plumbed and tested prior to fitting the boiler.

For ease of installation the appliance has a roll-in boiler tray which allows it to be rolled into place once the connections have been made.

Casing dimensions

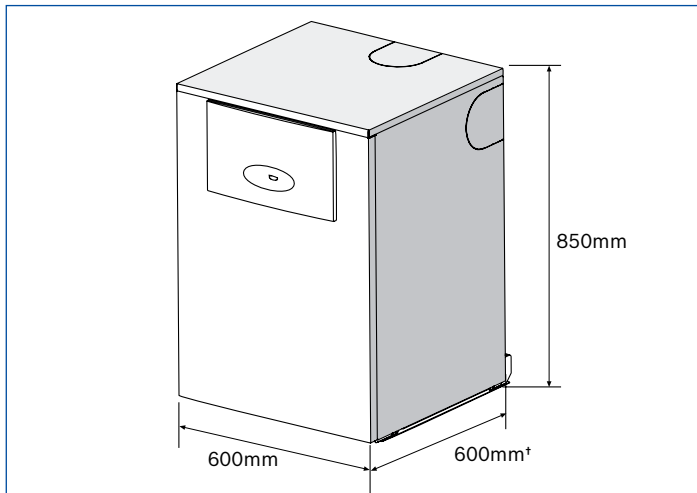

*630mm to front of flap.

Pipework connections

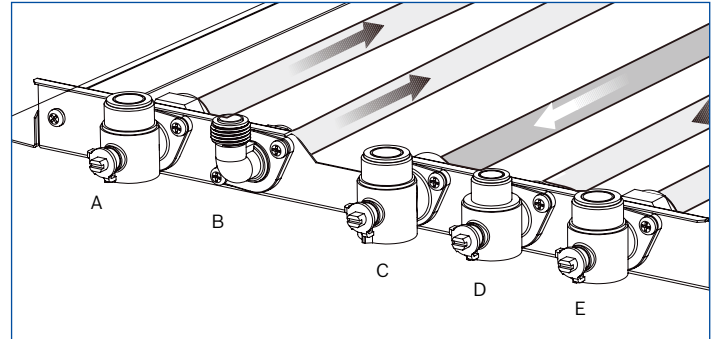

Pipework connections		
A	Central heating flow	22mm
B	DHW flow	22mm
C	Gas inlet	22mm
D	Cold main inlet	22mm
E	Central heating return	22mm

Site preparations and guidance – Greenstar FS CDi Regular

Greenstar FS CDi Regular boilers are designed for connection to a traditional heating and hot water system. The major benefits of the Greenstar FS CDi Regular boiler are:

- The boiler is compatible with S and Y plan systems
- The boiler comes with a roll-in boiler tray and pre-plumbing jig.

Greenstar FS CDi Regular boilers are exceptional for their number of additional time-saving installation features:

- Built-in frost sensor for boiler protection
- Built-in fault finding diagnostics
- Automatic gas pressure adjustment
- Highly versatile multi-directional fluing system
- Combined ignition and control board means fewer connections
- A rigid 22mm compression gas connection eliminating the need for pre-fabricating the gas pipe onto the isolating valve
- The large output range capability of the appliances.

Siting of appliance

General

The appliance is not suitable for external installation.

The appliance may be installed in an airing cupboard if required. See section “Compartment Installation” on page 26.

Clearances

The following clearances should be allowed for installation and servicing.

Installation clearances

The minimum space required to install the boiler only.

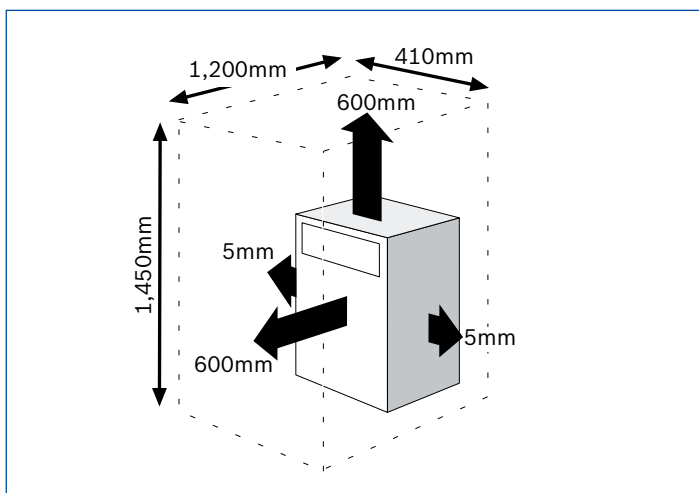

Service clearances

The minimum space required to service the boiler only.

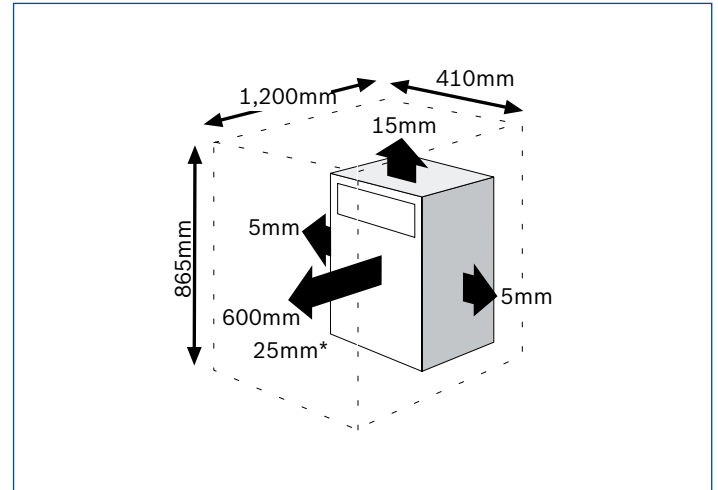

*25mm to a removable door

Pipework connections and casing dimensions

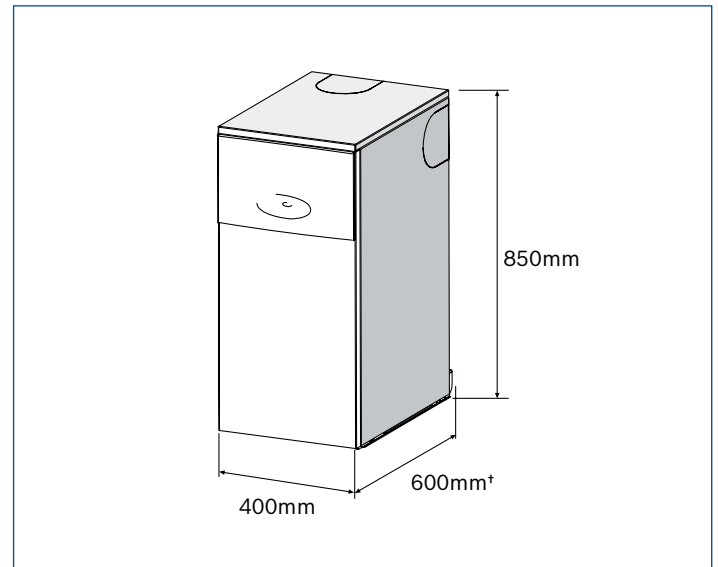

*630mm to front of flap.

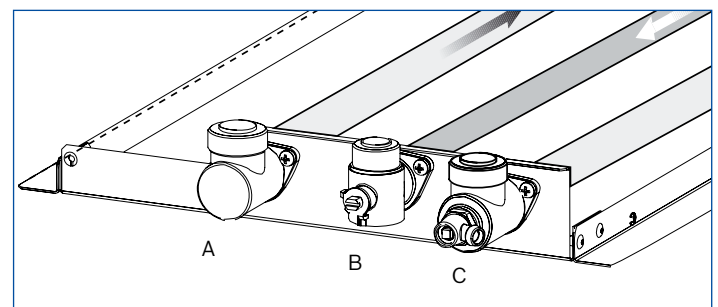

Pipework connections		
A	Central heating flow	22mm
B	Gas inlet	22mm
C	Central heating return	22mm

Compartment installation

The appliance may be installed in any room, although particular attention is drawn to the requirements of the IEE regulations applicable and in Scotland the electrical provisions with respect to installation in a room containing a bath or shower.

Air supply

1. The room in which the appliance is installed does not require a dedicated air vent.
2. If the appliance is installed in a cupboard or compartment with dimensions that allow the following minimum clearances, then no ventilation is required:

Compartment installation	
Position of appliance	Min. unventilated clearance (to removable door)
In front	200mm
Right side	100mm*
Left side	100mm*
Above	50mm

*This space can be reduced to 50mm for one side only as long as both the side clearances add up to the total of both of the side measurements shown or more.

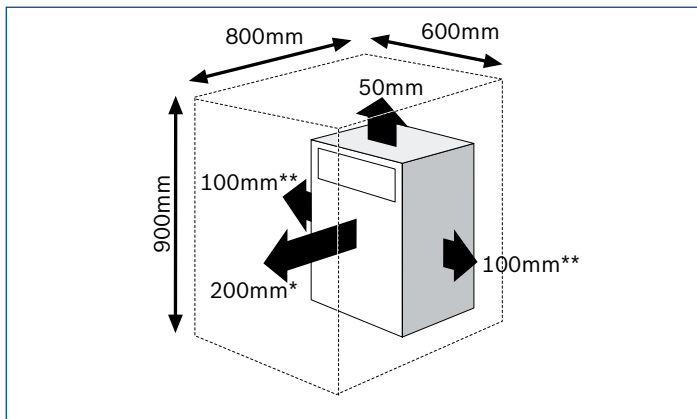

*Space required for unvented areas with a removable door or panel.

**This space can be reduced to 50mm for one side only as long as both the side clearances add up to the total of both the side measurements shown or more.

Boiler location & clearances

Bathrooms

IMPORTANT:

Any switch or appliance control using mains electricity must not be within reach of a person using the bath or shower.

Electrical switches, fused spurs and socket outlets must not be situated in the bathroom.

A boiler fitted with a non-mechanical timer or with no timer can be installed in zone 2 or outside the shaded area.

A boiler with a mechanical timer or RF mechanical timer with a room thermostat must only be installed outside the shaded area.

Additional Residual Current Device (RCD) protection may be required.

Refer to the latest IET (IEE) wiring regulations.

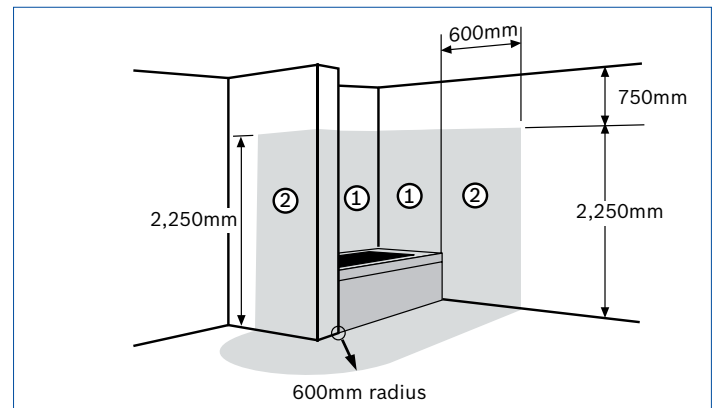
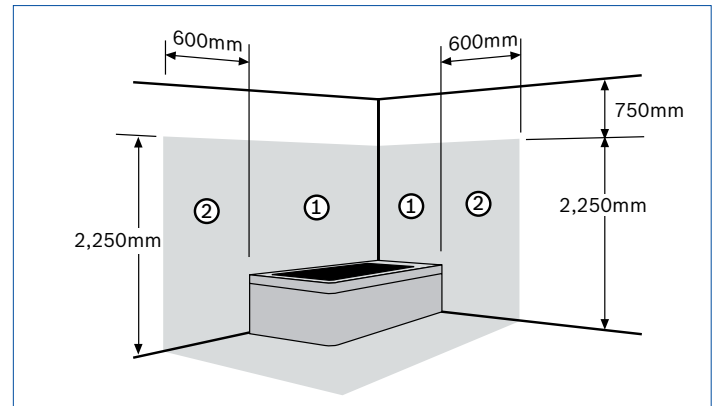

Installation requirements

Installation of Greenstar Highflow CDi combi boilers must be in accordance with the relevant requirements of the Gas Safety (Installation Use) Regulations at the time of installation, current IEE Wiring Regulations, local Building Regulations, Building Standards (Scotland) regulations and bylaws of the local Water company and Health and Safety Document No. 635 (Electricity at Work Regulations 1989). It should be in accordance with the relevant recommendations of the following British Standards:

BS 6798; BS 5449; BS 5546:1; BS 5440:1; BS 5440:2; BS 6891.

Gas Safety (Installation and Use) Regulations. All gas appliances must be installed by a Gas Safe registered person in accordance with the above regulations. Failure to install appliances correctly could lead to prosecution.

The manufacturers notes must not be taken in any way as overriding statutory regulations.

Protecting the heating system from dirty water

It is a requirement of the building standard, BS 7593, that all heating systems should be chemically flushed and cleansed and then an inhibitor added to help prevent future corrosion taking place. It is also beneficial and best practice within the building regulations to install a system filter.



Sealed primary systems

Worcester Greenstar Highflow CDi combi boilers are supplied complete with all the necessary components to form a sealed primary system. Included are a pre-plumbed expansion vessel (12 litres), a pressure relief valve (set at 3bar), an automatic air vent and a pressure gauge.

The expansion vessel fitted to the appliance will accommodate differing system volumes, depending upon its initial charge pressure, and system pre-pressurisation. The table below shows the system volume that can be accommodated under different conditions. If it is found that the system volume exceeds that catered for by the expansion vessel fitted within the appliance, then an extra vessel should be added as close to the appliance as possible in the heating return pipe. Refer to BS 5449:1 and BS 6798:1 for further information.

Total system volume – litres (gallons)			
Initial system pressure (bar)	Initial charge pressure (bar)		
	0.5	1.0	1.5
0.5	130 (29)	–	–
1.0	80 (17.5)	102 (22.5)	–
1.5	43 (9.5)	58 (13)	71 (15.5)
2.0	20 (4.5)	27 (5.9)	33 (7.5)

System filling and make-up

To comply with the Water Authority requirements, the system should be filled via a temporary hose connection to the mains cold water supply, with a double check valve assembly and a test point fitted to the mains water side of the temporary circuit. This is supplied within the boiler.

Valves and joints

It is very important that all valves and joints are able to sustain a working pressure of up to 3bar (45psi). Particular care should be exercised when fitting radiator valves and only those of high quality to BS 2767:10 should be used. All other valves and fittings should comply with BS 1010.

Loss of water pressure from a sealed system will require continuous recharging with fresh water and consequential introduction of air. Air is highly corrosive and will considerably reduce life expectancy of radiators, pumps etc.

Plastic pipework

The use of plastic pipework is acceptable. However, some plastics are permeable to oxygen and must be avoided. Only pipework with a polymeric barrier should be used. Please note that the first 600mm of pipework connected to the boiler must be copper.

Open vented primary systems

It is not permissible to install a Greenstar Highflow CDi combi on an open vent system.

Natural gas supply

Appliances, when on a full output demand, will require up to 3.1m³/hr of gas for the 440CDi and 4.4m³/hr of gas for the 550CDi. The gas meter and supply pipes must be capable of supplying this quantity of gas in addition to the demand from any other appliance being served. It is important that a gas supply pipe of at least 22mm diameter is used. Under no circumstances should the size of the gas supply pipe be less than that of the appliance inlet connection. The meter outlet should be capable of ensuring a nominal pressure of 20mbar (8in wg) at the appliance. Particular consideration should be given to the resistance to gas flow created by elbows, bends etc. Pipework should be sized to overcome this resistance, details of this are given in the table below.

	Total length of gas supply pipe (m)			Pipe diameter (mm)
	3	6	9	
Gas discharge rate m ³ /h	2.9	–	–	15
	8.7	5.8	4.6	22
	18.0	12.0	9.4	28

Approximate additional length to be allowed (natural gas)

Elbows or tees		90° bends	
Metres	Feet	Metres	Feet
0.50	2	0.3	1

Liquid Petroleum Gas (LPG) supply

The appliances, when on a hot water or full output demand, will require up to 2.3kg/hr of gas for the 440CDi and 3.2kg/hr of gas for the 550CDi. The gas tank or bottles must be capable of supplying this quantity of gas at a nominal pressure of 37mbar (14.8in wg) at the appliance. The table shows the LPG discharge through varying lengths of pipe and the resistance to flow created by elbows, bends etc. Pipework should be sized so as to overcome this resistance.

	Total length of gas supply pipe (m)			Pipe diameter (mm)
	3	6	9	
Gas discharge rate m ³ /h	8.0	5.2	4.2	22
	15.9	8.8	8.3	28

Approximate additional length to be allowed (LPG)

Elbows or tees		90° bends	
Metres	Feet	Metres	Feet
0.6	2	0.3	1

Electricity supply

A 3amp fused three pin plug and unswitched shuttered socket outlet (both complying with BS 1363) or preferably a double pole isolator with a contact separation of 3mm in all poles supplying the appliance should be used.

The appliance electrical circuits are also protected by an internal 2.5amp fuse. The appliance must be earthed.

Mains cold water supply

Water Authority requirement

A direct mains cold water connection is permitted by Water Authorities, however, it is recommended that reference be made to local requirements. In the event of difficulty contact the Worcester Technical Support Department.

Pipe sizing

Unless the mains pressure is low, a standard 22mm diameter service pipe is normally suitable. A 22mm hot water distribution pipe to the first branch is recommended thereafter 15mm and/or 10mm to all draw off points.

Cold water connection

Wherever possible the cold supply to the appliance should be the first connection off the mains supply, in order to minimise hot water flow reduction when cold water services are operated. The final 600mm of piping to the appliance should be of copper only.

Cold water pressure

To achieve the stipulated flow rates of 20l/min (4.4gpm)/ 25l/min (5.5gpm) a working cold water mains pressure of 1.5bar/1.7bar is required. The appliance will operate at a minimum working pressure of only 0.5bar (7.5psi), however a reduced hot water flow rate should be expected. Back-flow prevention devices, including water meters, can prevent the expansion of hot water into the cold

water main. However, this can result in a pressure build-up that may cause damage to the boiler and household devices such as showers, washing machines etc. In these cases we recommend that a mini-expansion vessel (Part No. 7 716 192 105) be fitted adjacent to the boiler in the cold water main.

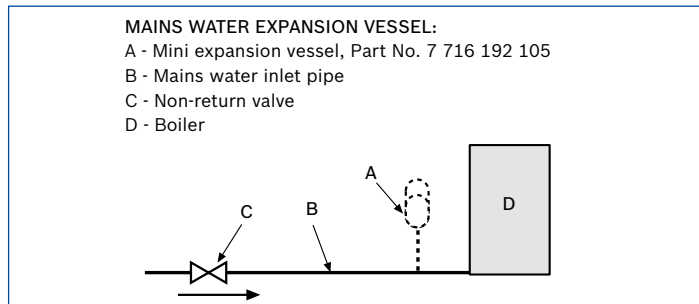

Hot water supply

As with all mains fed systems, the flow rate of water obtainable from individual taps will vary in relation to the number of taps operating simultaneously, and will depend upon the cold mains supply available to the property.

Therefore, in order to avoid excessive starvation of flow to individual taps, flow balancing may be required by the use of proprietary constant volume flow regulators or Ball-o-Fix valves.

Hot water systems

Taps and valves

Hot and cold taps and mixing valves used with Greenstar Highflow CDi appliances must be suitable for operating at a mains pressure of up to 10bar (150psi) and temperatures of 65°C (150°F).

Showers

When a loose head shower with a flexible hose is used over a bath or shower tray, the hose must be fixed so that the head cannot fall closer than 25mm (1in) above the top edge of the spill over level of the relevant bath or shower tray. Alternatively, the feed pipes to the shower should incorporate a double check valve assembly or a check valve and vacuum breaker.

With fixed head showers no provision is necessary.

The use of a thermostatically controlled shower will give added comfort and safeguard against high hot water temperatures.

Bidet

The supply of hot and cold water mains direct to a bidet is permitted provided that the bidet is of the overrim water feed type. The outlet(s) should be shrouded and not have any temporary hand held spray attached. No other anti-siphonage arrangements are necessary.

Use in hard water areas

As the maximum temperature of the domestic hot water heat exchanger is limited by the electronic control circuit, there is normally no need for water treatment to prevent scale accumulation.

In areas where exceptional water conditions prevail, consideration may need to be given to the fitting of a device capable of preventing scale. In such circumstances the advice of the local water authority should be sought.

Guarantee

Worcester Greenstar combi appliances are offered with a full 5 year guarantee* on parts and labour and a 10 year guarantee* on the primary heat exchanger*. Ongoing service and maintenance contracts can be arranged through the Worcester Customer Service Department.

Please contact our guarantee registration advisors on 0330 123 2552 or visit worcester-bosch.co.uk/guarantee



On all Greenstar combi appliances* On the primary heat exchanger*

*Subject to terms and conditions.

The NEW Greenstar System Filter

NEW

Available in 22mm and 28mm, the Worcester Greenstar System Filter has been specifically designed to combat the damaging effects of system debris and pollutants, allowing homeowners to protect their boiler or heat pump for a fraction of its cost.

Inspired by installer feedback, the new filter has been designed to make installation and servicing simpler than ever before. In addition the performance has been improved resulting in a greater collection of debris from the system.

Please note: CIBSE heating guide recommends, for a condensing boiler system, anything running continuously over 23kW is likely to require 28mm pipework and therefore a 28mm filter. However, this will be dependent on the system layout and pressure drop.



NEW features and improvements



✔ Over-tightening prevention feature

The removable lid has been designed to prevent over-tightening and damage to the O-ring seal, eliminating the risk of leaks.

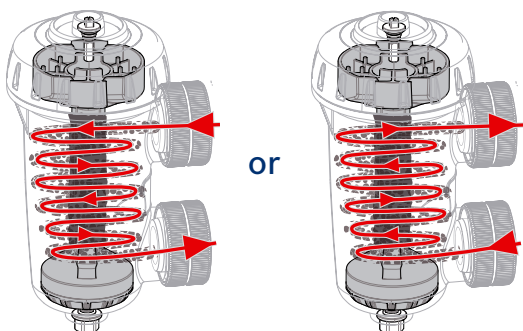

✔ Bi-directional flow

Engineered to allow a bi-directional flow, enabling it to be installed anywhere along the return circulation pipework between the last radiator and the boiler.



✔ Isolation valve indicators

The isolation valves can be opened using a single 90° turn, with red and green indicators showing when the filter is in operation.



✔ Stronger magnet

A larger powerful internal magnet safeguards the boiler and wider system components.



✔ **28mm version now available**

A larger version is now available for use in larger heating systems.



✔ **Pipe cut template**

A cutting guide is supplied with the filter for use in measuring exact lengths of pipe to cut at the point at which the filter is being installed.



✔ **Easy to fit**

Although the Greenstar System Filter shares its name with our high efficiency gas and oil-fired boilers, it can also be fitted to any typical domestic heating system.



✔ **Easy to service**

The Greenstar System Filter has been designed to make servicing and maintenance simple by using the special spanners supplied and a radiator bleed key.

Installation

The filter can be installed anywhere in a heating system, except between the boiler and on the feed and expansion pipes on an open vent system. To maximise the effectiveness it should be placed on the primary heating return before the boiler and after the last radiator.

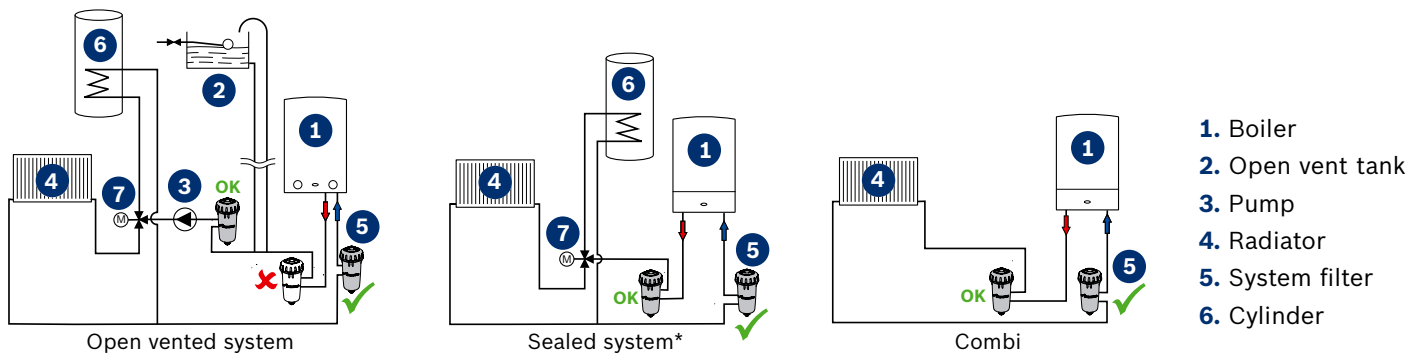

*When a system boiler has an internal diverter valve and two returns, the system filter should be put on the heating return and not the cylinder return.

Product info	
Part numbers	7 733 600 236 (22mm)
	7 733 600 237 (28mm)

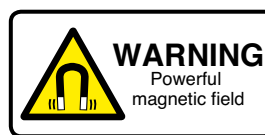

MAGNETIC FIELD.
Can be harmful to
pacemaker wearers.

Condensate pipework

All condensing boilers generate condensate discharge which needs to be piped away from the appliance using a plastic pipe.

The amount of condensate generated depends on the efficiency and operating status of the appliance. Depending on operating temperatures, the appliance will condense in both heating and hot water modes and may generate up to 2.7 litres of condensate per hour for the 440CDi and 3.7 litres per hour for the 550CDi Regular.

Condensate termination and route

Greenstar Highflow CDi combi boilers incorporate a condensate pump which allows condensate to be plumbed above the boiler, allowing more flexible siting possibilities.

Condensate connection

The condensate pump fills up and periodically discharges through the flexible condensate pipe between 200mm and 4,500mm from floor level. After this point the condensate continues down the 22mm rigid pipework to the outlet using gravity.

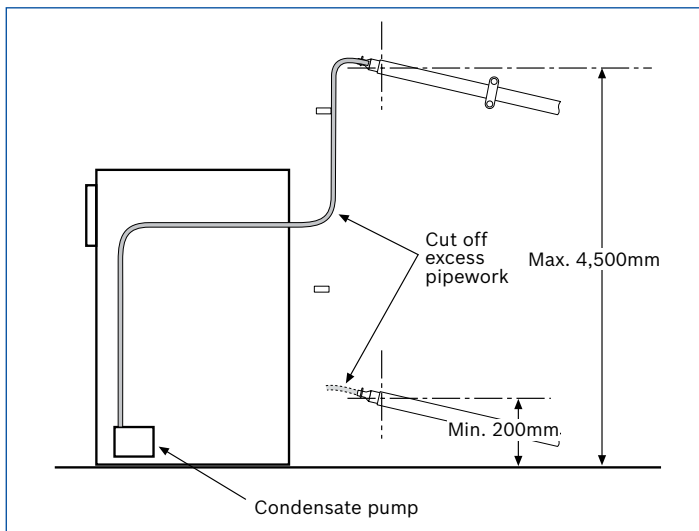

- The flexible plastic pipe can be reduced in length to suit the installation circumstances. The pipework must follow one of the options shown opposite.

Never terminate or discharge into any open source, including: sink, bath, shower, bidet, toilet etc.

Note: any external condensate pipework should be protected with weather resistant insulation to help prevent freezing.

The condensate connection on Worcester appliances is in 22mm polypropylene. The pipe should be extended and run away from the appliance with a constant fall of 3° or at least 50mm in every metre away from the boiler.

The condensate pipe can terminate into any one of four areas.

Whilst all of the methods are acceptable it is best practise to terminate the condensate pipe via an internal waste system. This will eliminate the need for any external condensate pipe runs which can be susceptible to freezing in extreme weather. Best practise is not to run external condensate pipe any further than 3m. If it is necessary to run more than 3m externally increase pipe size to 32mm.

Condensate termination and route

External condensate pipework

The Worcester Greenstar Highflow CDi combi appliances have a condensate pump rather than a siphonic condensate trap. Rather than the condensate constantly dripping into the discharge pipe, the condensate is collected in the pump which releases it in 100ml quantities. This will help prevent freezing occurring.

Wherever possible the condensate discharge pipework should be routed and terminated internally. Should this not be possible, and the only available route is external, the following conditions should be observed:

- The pipework length should be kept to a minimum and the route as vertical as possible
- Where pipework could be subjected to extreme cold or wind chill, a weather proof insulation should be used. **Alternatively, the condensate pipework could be increased to a minimum 32mm.**

For full technical information on pipe size, insulation and different condensate pipework methods, please see Installation, Commissioning and Servicing Instruction Manual.

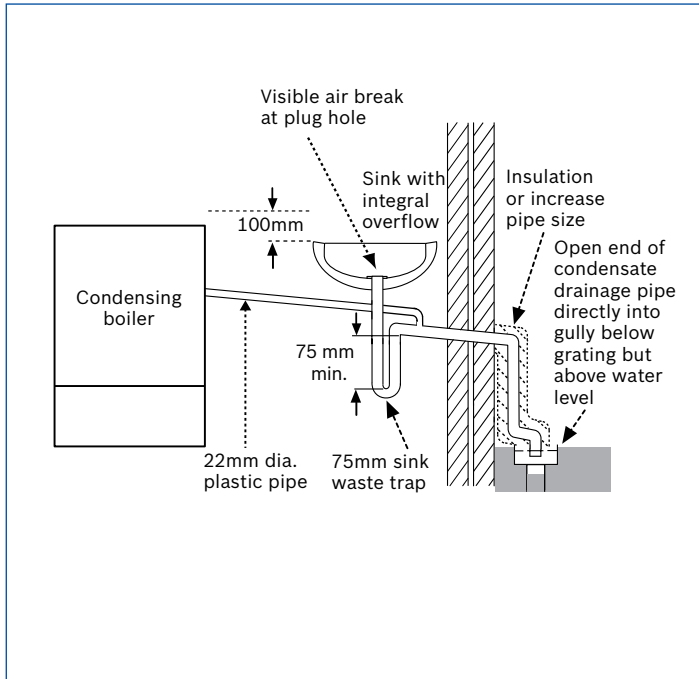

Internal sink/washing machine drain

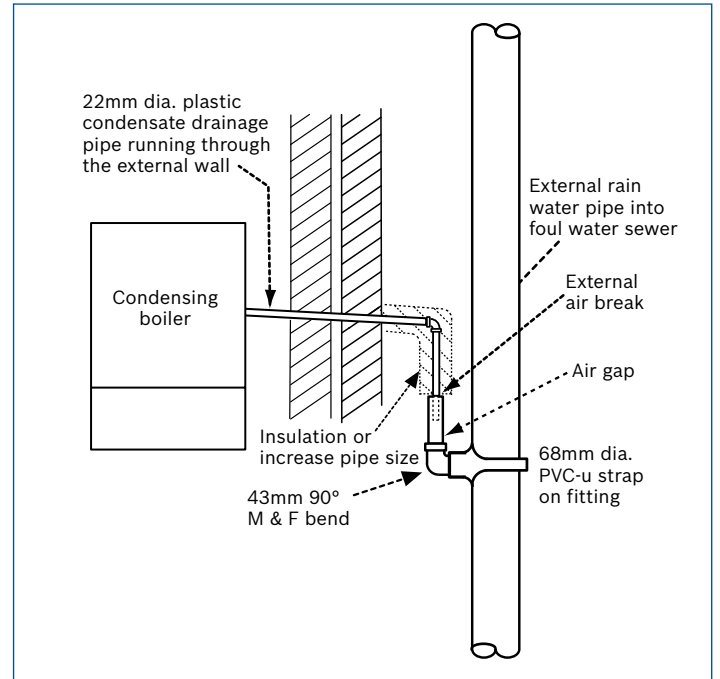

External air break when using a foul water down pipe

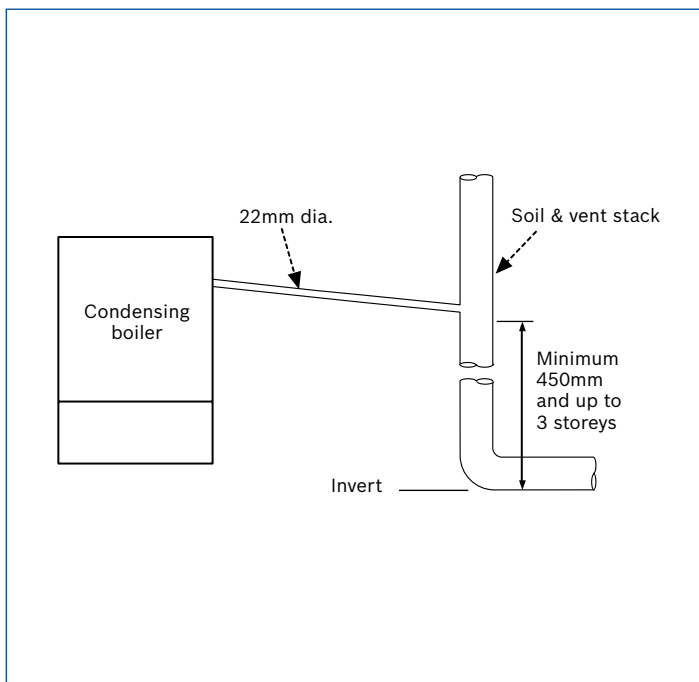

Soil and vent stack

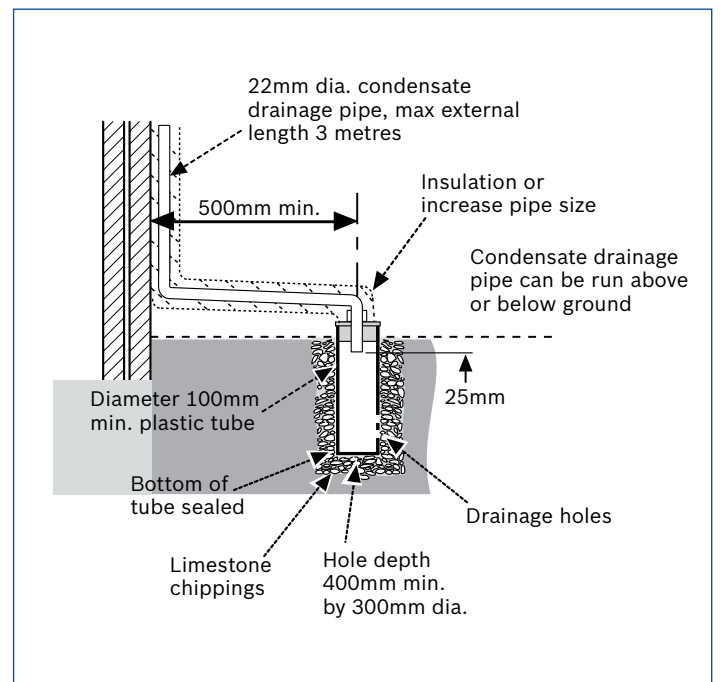

External condensate absorption point (unsuitable for clay soil types)

Horizontal and vertical flue terminal positioning

All measurements in millimetres

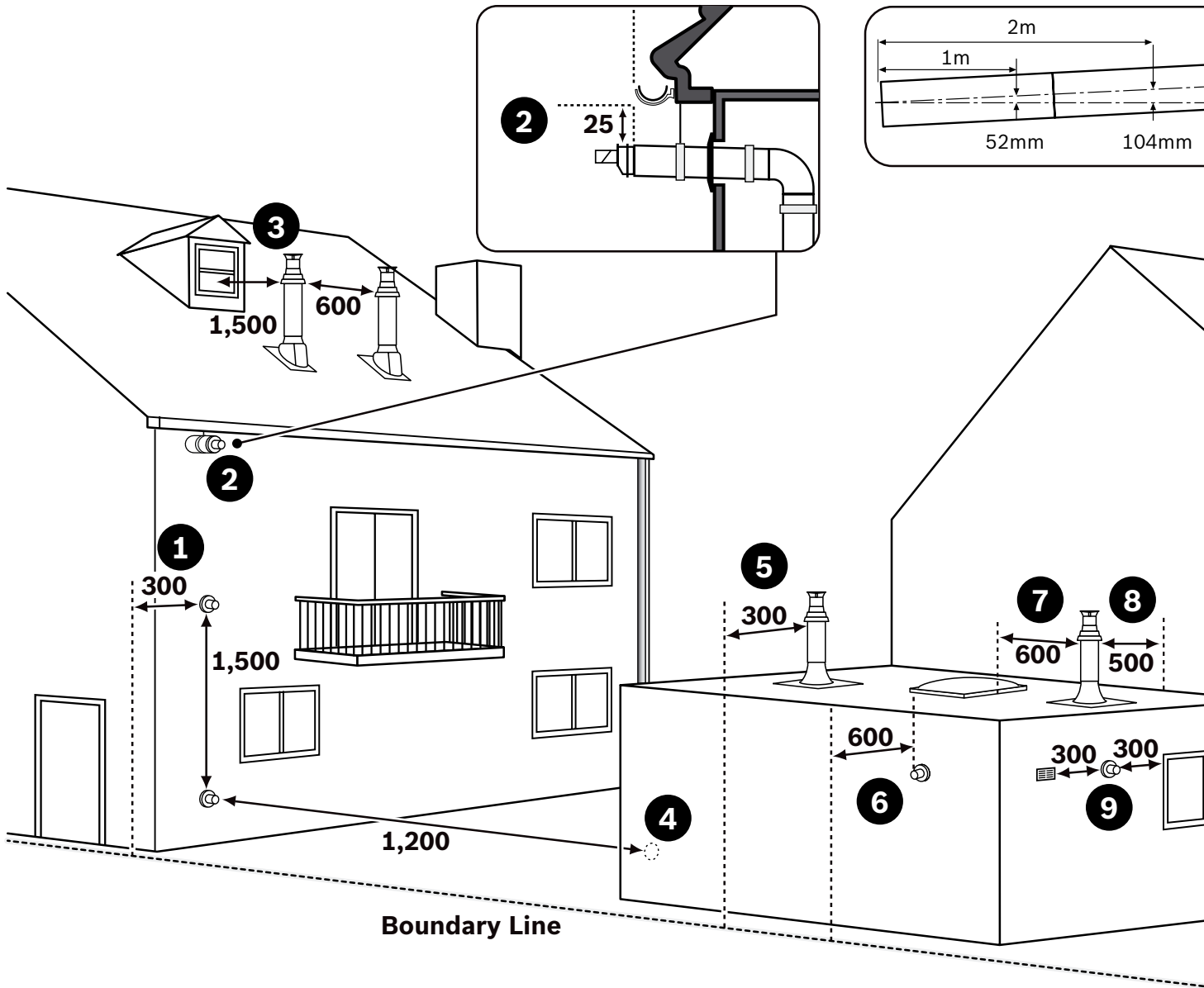

Note

- All measurements are the minimum clearances required
- Terminals must be positioned so as to avoid combustion products entering the building
- Support the flue at approximately one metre intervals and at a change of direction, use suitable brackets and fittings.

Flue bracket part numbers:

7 716 191 177 (100mm dia.)

7 716 191 178 (100mm dia. x 6)

7 716 191 179 (125mm dia.)

Key to illustration

1. 300mm adjacent to a boundary line.
2. The dimension below eaves, balconies and car ports can be reduced to 25mm, as long as the flue terminal is extended to clear any overhang. External flue joints must be sealed with suitable silicon sealant.
3. 1,500mm between a vertical flue terminal and a window or dormer window.
4. 1,200mm between terminals facing each other.
5. Vertical flue clearance, 300mm adjacent to a boundary line.
6. 600mm distance to a boundary line, unless it will cause a nuisance. BS 5440:Part 1 recommends that care is taken when siting terminal in relation to boundary lines.
7. 600mm minimum clearance from a skylight to a vertical flue.
8. Vertical flue clearance, 500mm to non-combustible building material, and 1,500mm clearance to combustible building material.

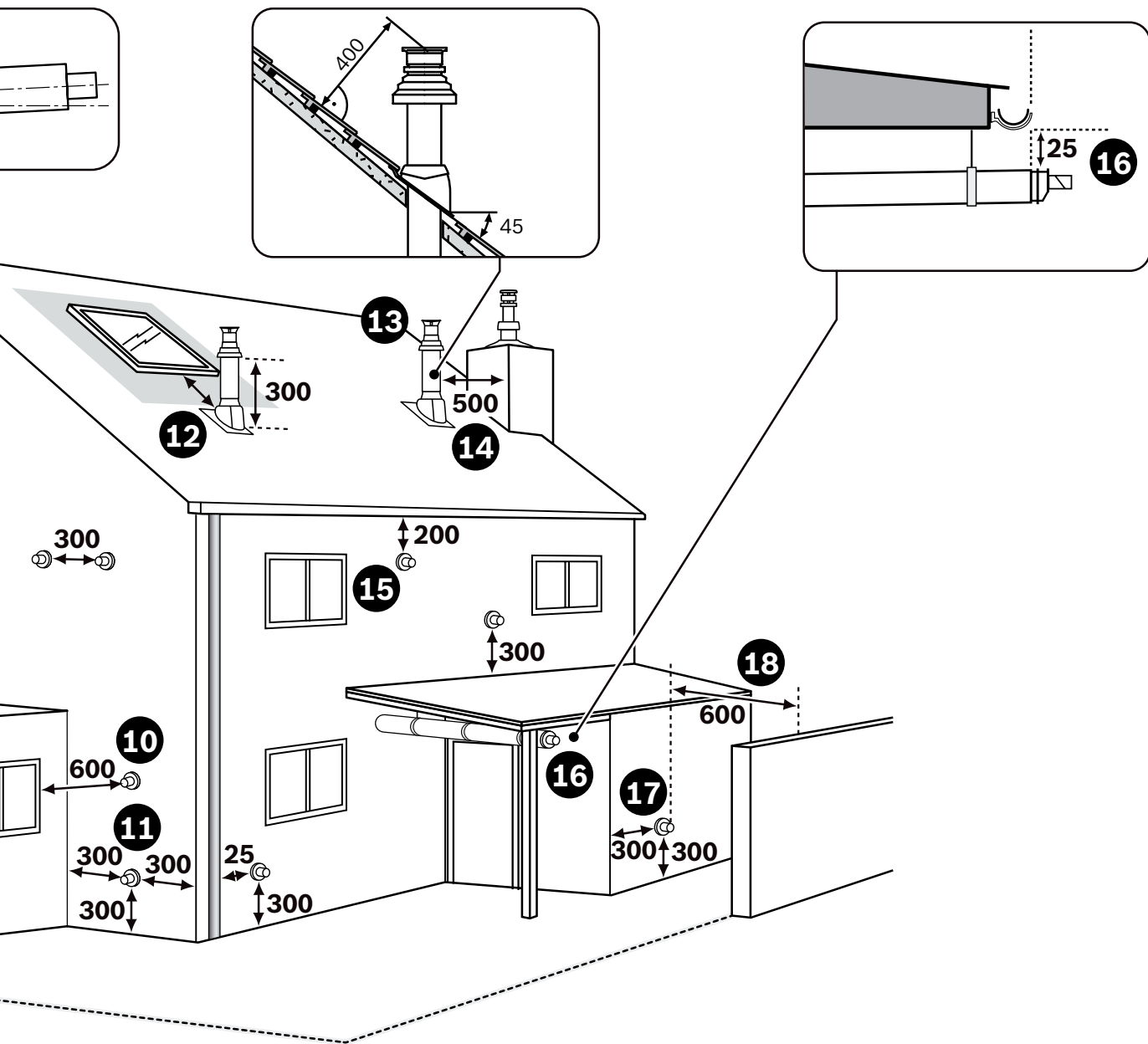

9. 300mm above, below and either side of an opening door, air vent or opening window.
 10. 600mm diagonally to an opening door, air vent or opening window.
 11. 300mm to an internal or external corner.
 12. 2,000mm below a Velux window, 600mm above or to either side of the Velux window.
 13. 400mm from a pitched roof or 500mm in regions with heavy snowfall.
 14. 500mm clearance to any vertical structure on a roof, 600mm to room sealed flue or 1,500 to an open flue.
 15. 200mm below eaves and 75mm below gutters, pipe and drains.
 16. The dimension below eaves, balconies and car ports can be reduced to 25mm, as long as the flue terminal is extended to clear any overhang. External flue joints must be sealed with suitable silicon sealant.
 17. Flue clearance must be at least 300mm from the ground. Terminal guards must be fitted if the flue is less than 2 metres from the ground or if a person could come into contact with the flue terminal.
 18. 600mm distance to a surface facing a terminal, unless it will cause a nuisance. BS 5440: Part 1 recommends that care is taken when siting terminals in relation to surfaces facing a terminal.
- **Installations in car ports are not recommended**
 - **The flue cannot be lower than 1,000mm from the top of a light well due to the build up of combustion products**
 - **Dimensions from a flue terminal to a fanned air inlet to be determined by the ventilation equipment manufacturer.**

Horizontal fluing options

Greenstar Highflow CDi and Greenstar FS CDi Regular boilers offer a choice of 2 different sized horizontal RSF flue systems, 100mm diameter and 125mm diameter. The systems have different maximum lengths. Options 1 to 8 detail the permissible lengths.



Horizontal RSF flue

Flue diameter	100mm	125mm
Minimum flue length	130mm	350mm
Maximum flue length	4,000mm	13,000mm

100mm dia. telescopic flue kit

Comprises:

- 1 x internal flue connector bend
- 1 x flue adaptor
- 1 x flue connector
- 2 x wall cover plates
- 530mm (100mm dia.) of flue duct including terminal











Part No. 7 716 191 155







125mm dia. standard flue kit

- 1 x internal flue connector bend
- 1 x flue adaptor
- 1 x flue connector
- 2 x wall cover plates
- 965mm (125mm dia.) of flue duct including terminal

Part No. 7 716 191 157

Accessories

Components	Part No.	Description
100mm diameter		
	7 716 191 155	Horizontal telescopic kit (530mm)
	7 733 600 048^	High level horizontal telescopic flue kit
	7 716 191 083	Extension flue kit (960mm*)
	7 716 191 172	2m flue extension
	7 716 191 133	Short flue extension (220mm*)
	7 716 191 084	90° bend
	7 716 191 085	45° bend
	7 716 191 164	Vertical flue adaptor
	7 716 191 177	Support bracket kit
	7 716 191 178	Support bracket kit (6 pack)

125mm diameter		
	7 716 191 157	Horizontal flue kit (965mm)
	7 719 003 666	Extension flue kit (960mm*)
	7 719 003 664	90° bend
	7 719 003 665	45° bend
	7 716 191 165	Vertical flue adaptor
	7 716 191 179	Support bracket kit

*Dimensions when fitted



^For use with high level horizontal flue adaptor and flue adaptor part number 8 716 682 324 0

The following criteria should be noted when planning the installation:

- The concentric flue system must be inclined at 3° (52mm per metre) from the appliance, to allow condensate to drain back into the boiler
- A white plume of condensation will be emitted from the terminal because the appliance operates at high efficiency. Care must be taken when selecting the flue terminal position
- To achieve a maximum flue length, one of the extension flue kits will need to be cut so that the permitted maximum flue length is not exceeded
- Horizontal flue options 1-8 illustrate common flue installations. Other configurations of the flue system are possible up to, and not exceeding, the stated maximum flue lengths.

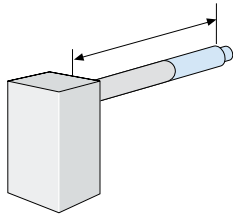

Option 1: Extension rear flue horizontal flue assembly



Components			
Part No. 100mm		7 716 191 155	7 716 191 083
Part No. 125mm		7 716 191 157	7 719 003 666
Maximum lengths (mm) & no. of components required			
Greenstar Highflow CDi & Greenstar FS CDi Regular series			
100mm	4,000	1	up to 4
125mm	13,000	1	up to 12

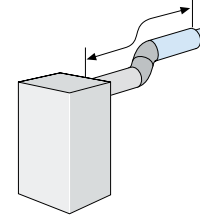

Option 3: Extension rear flue horizontal using 45° bends



Components				
Part No. 100mm		7 716 191 155	7 716 191 083	7 716 191 085
Part No. 125mm		7 716 191 157	7 719 003 666	7 719 003 665
Maximum lengths (mm) & no. of components required				
Greenstar Highflow CDi & Greenstar FS CDi Regular series				
100mm	2,500	1	up to 2	2
125mm	11,000	1	up to 10	2

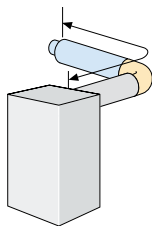

Option 2: Extension rear flue horizontal using a 90° bend

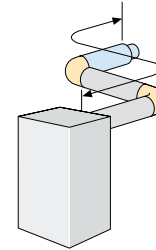

Components				
Part No. 100mm		7 716 191 155	7 716 191 083	7 716 191 084
Part No. 125mm		7 716 191 157	7 719 003 666	7 719 003 664
Maximum lengths (mm) & no. of components required				
Greenstar Highflow CDi & Greenstar FS CDi Regular series				
100mm	2,500	1	up to 2	1
125mm	11,000	1	up to 10	1

Option 4: Extension rear flue horizontal using a second 90° bend



Components				
Part No. 100mm		7 716 191 155	7 716 191 083	7 716 191 084
Part No. 125mm		7 716 191 157	7 719 003 666	7 719 003 664
Maximum lengths (mm) & no. of components required				
Greenstar Highflow CDi & Greenstar FS CDi Regular series				
100mm	1,000	1	up to 2	2
125mm	9,000	1	up to 8	2

Note: The short flue extension (100mm dia.) may be used as an alternative to the standard extension as required up to the maximum flue lengths stated (Part No. 7 716 191 133).

Note: The maximum flue length must be reduced by the following amounts for each bend used.

	45° bend	90° bend
60/100mm flues	750mm	1,500mm
80/125mm flues	750mm	1,500mm

Option 5: Extension flue upwards and horizontal

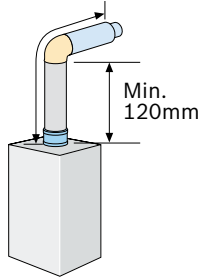

Components					
Part No. 100mm	7 716 191 155	7 716 191 083	7 716 191 084	7 716 191 164	
Part No. 125mm	7 716 191 157	7 719 003 666	7 719 003 664	7 716 191 165	
Maximum lengths (mm) & no. of components required					
Greenstar Highflow CDi & Greenstar FS CDi Regular series					
100mm	2,500	1	up to 2	1	1
125mm	11,000	1	up to 10	1	1

Option 7: Extension flue upwards and horizontal using a third 90° bend

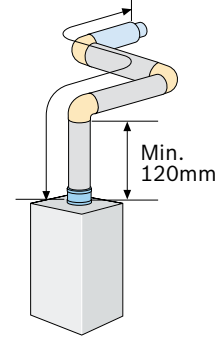

Components					
Part No. 100mm	7 716 191 155	7 716 191 083	7 716 191 084	7 716 191 164	
Part No. 125mm	7 716 191 157	7 719 003 666	7 719 003 664	7 716 191 165	
Maximum lengths (mm) & no. of components required					
Greenstar Highflow CDi & Greenstar FS CDi Regular series					
100mm	N/A	N/A	N/A	N/A	N/A
125mm	7,000	1	up to 6	3	1

Option 6: Extension flue upwards and horizontal using a second 90° bend

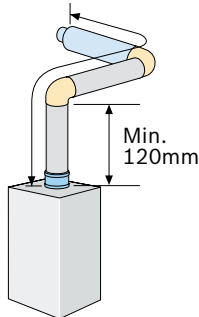

Components					
Part No. 100mm	7 716 191 155	7 716 191 083	7 716 191 084	7 716 191 164	
Part No. 125mm	7 716 191 157	7 719 003 666	7 719 003 664	7 716 191 165	
Maximum lengths (mm) & no. of components required					
Greenstar Highflow CDi & Greenstar FS CDi Regular series					
100mm	1,000	1	up to 2	2	1
125mm	9,000	1	up to 8	2	1

Option 8: Side flue extension using two 45° bends

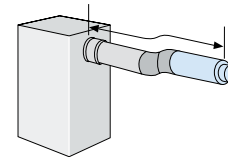

Components				
Part No. 100mm	7 716 191 155	7 716 191 083	7 716 191 085	7 716 191 164
Part No. 125mm	7 716 191 157	7 719 003 666	7 719 003 665	7 716 191 165
Maximum lengths (mm) & no. of components required				
Greenstar Highflow CDi & Greenstar FS CDi Regular series				
100mm	2,500	1	up to 2	2
125mm	11,000	1	up to 10	2

Note: The short flue extension (100mm dia.) may be used as an alternative to the standard extension as required up to the maximum flue lengths stated (Part No. 7 716 191 133). For high level horizontal flue discharges (options 5, 6 and 7) the flue adaptor (part number 8 718 682 324 0) may be required.

Note: The maximum flue length must be reduced by the following amounts for each bend used.

	45° bend	90° bend
60/100mm flues	750mm	1,500mm
80/125mm flues	750mm	1,500mm

Vertical fluing options

Greenstar Highflow CDi and Greenstar FS CDi Regular boilers offer a choice of 2 different sized vertical RSF systems, 100mm diameter and 125mm diameter. Both systems have different maximum lengths. Options 1 to 3 detail the permissible lengths.



Vertical RSF flue

Flue diameter	100mm	125mm
Flue terminal assembly diameter	120mm	135mm
Maximum flue length (inc. terminal)	6,400mm	15,000mm
Flue terminal assembly length	1,140mm	1,365mm

Vertical balanced flue kit











Comprises:







- 1 x flue terminal assembly
- 1 x weather sealing collar
- 1 x fire stop spacer
- 1 x vertical flue adaptor
- 1 x wall bracket
- 1 x flue adaptor

Part No. 7 716 191 156 (100mm dia.)

Part No. 7 716 191 158 (125mm dia.)

Accessories

Components	Part No.	Description
100mm diameter		
	7 716 191 156	Vertical 1,140mm kit
	7 716 191 083	Extension flue kit (960mm*)
	7 716 191 172	2m flue extension
	7 716 191 133	Short flue extension (220mm*)
	7 716 191 084	90° bend
	7 716 191 085	45° bend
	7 716 191 090	Flashing – flat roof
	7 716 191 091	Flashing – pitched roof
	7 716 191 177	Support bracket kit
	7 716 191 178	Support bracket kit (6 pack)

125mm diameter		
	7 716 191 158	Vertical 1,365mm kit
	7 719 003 666	Extension flue kit (960mm*)
	7 719 003 664	90° bend
	7 719 003 665	45° bend
	7 716 191 090	Flashing – flat roof
	7 716 191 091	Flashing – pitched roof
	7 716 191 179	Support bracket kit



*Dimensions when fitted

The following criteria should be noted when planning the installation:

- Because the appliance operates at high efficiency, a white plume of condensation will be emitted from the terminal. Care must be taken when selecting the flue terminal position
- To achieve a maximum flue length, one of the extension flue kits will need to be cut so that the permitted maximum flue length is not exceeded
- Vertical flue options 1-3 illustrate common flue installations. Other configurations of the flue system are possible up to, and not exceeding, the stated maximum flue lengths.

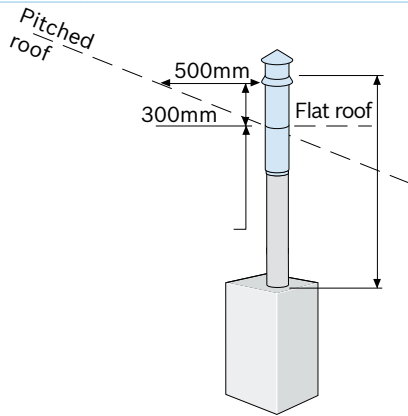

Option 1: Vertical balanced flue assembly



Components			
Part No. 100mm		7 716 191 156	7 716 191 083
Part No. 125mm		7 716 191 158	7 719 003 666
Maximum lengths (mm) & no. of components required			
Greenstar Highflow CDi & Greenstar FS CDi Regular series			
100mm	6,400	1	up to 6
125mm	15,000	1	up to 14

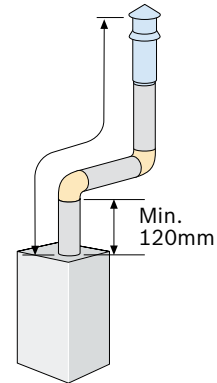

Option 3: Vertical balanced flue using two 90° bends

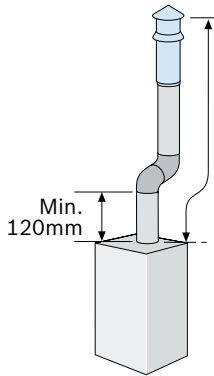

Components				
Part No. 100mm		7 716 191 156	7 716 191 083	7 716 191 084
Part No. 125mm		7 716 191 158	7 719 003 666	7 719 003 664
Maximum lengths (mm) & no. of components required				
Greenstar Highflow CDi & Greenstar FS CDi Regular series				
100mm	3,400	1	up to 3	2
125mm	11,000	1	up to 10	2

Option 2: Vertical balanced flue using two 45° bends



Components				
Part No. 100mm		7 716 191 156	7 716 191 083	7 716 191 085
Part No. 125mm		7 716 191 158	7 719 003 666	7 719 003 665
Maximum lengths (mm) & no. of components required				
Greenstar Highflow CDi & Greenstar FS CDi Regular series				
100mm	4,900	1	up to 5	2
125mm	13,000	1	up to 12	2

Note: The short flue extension (100mm dia.) may be used as an alternative to the standard extension as required up to the maximum flue lengths stated (Part No. 7 716 191 133).

Note: The maximum flue length must be reduced by the following amounts for each bend used.

	45° bend	90° bend
60/100mm flues	750mm	1,500mm
80/125mm flues	750mm	1,500mm

Greenstar FS CDi Regular series flexible flue system for chimney installations

Greenstar FS CDi Regular boilers can be used with a flexible flue system which utilises an existing chimney in the building to route the flue terminating on top of the chimney. It is available in one size – 80mm diameter and 12m length. The flexible liner can be cut down from the 12m length to suit.

80mm flexible flue system

Comprises:

- 1 x flue terminal (A)
- 1 x chimney cowl (B)
- 1 x self-adhesive weather seal (C)
- 1 x terminal adaptor (D)
- 1 x support bracket assembly (E)
- 2 x liner (F)
- 2 x seal (G)
- 1 x flexible liner (H)
- 4 x centralising spacers (I)
- 1 x support bend adaptor (J)
- 1 x support bend (K)
- 1 x bend support (L)
- 2 x flue inspection plates (M)
- 1 x seal for flue inspection plates (N)
- 1 x 125mm flue extension (O)
- 1 x tee piece (P)
- 1 x 125mm flue connector (Q)
- 1 x 80/80mm flue adaptor (R)

Part No. 7 716 191 159

Flexible flue terminal clearances

The same clearances apply as for the vertical flue as shown in the flue terminal positioning diagram on pages 34 and 35.

Requirements for the chimney

The flexible flue system is designed to be installed through a hole in the side of the chimney as shown in the diagram opposite.

This will necessitate cutting a hole 150mm min./260mm max. width and 360mm min./390mm max height into the chimney.

To avoid debris falling into the air inlet duct, do not install the duct with the open end facing up the chimney.

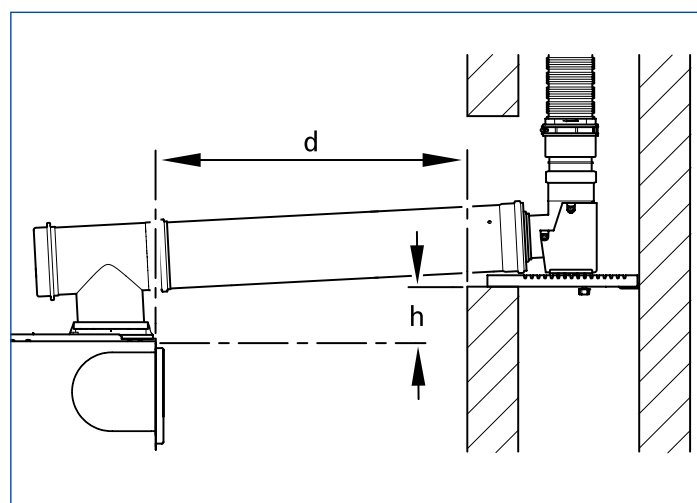
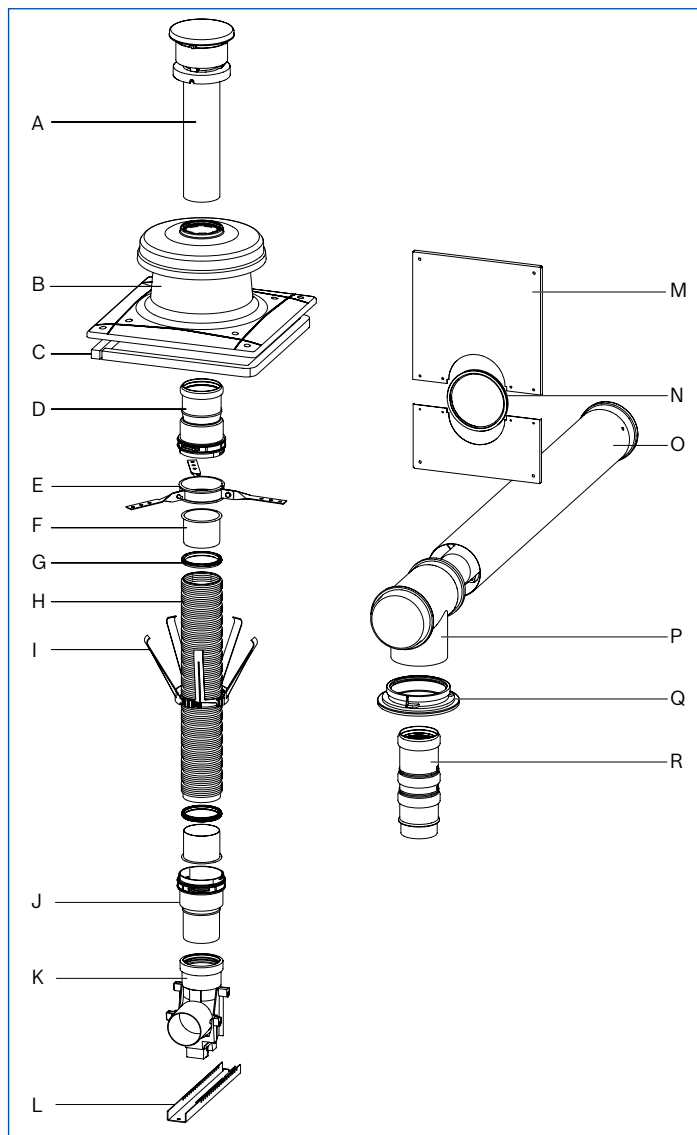

Requirements for the chimney

Chimney size

Ensure the cross section of the chimney complies with the diagram and table below.

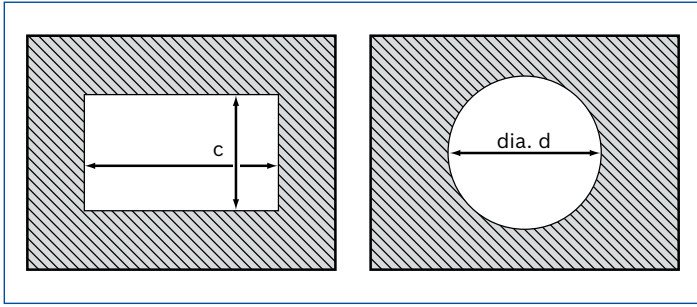

Chimney size (mm)			
'c' min	'c' max	'dia. d' min	'dia. d' max
130	300	146	300

Fire resistance

The materials used for the construction of the chimney must be fire resistant in compliance with the figures stated below.

Type of building	Fire resistance
Single storey	30 minutes
Multi-storey	90 minutes

Preparing the chimney

- The chimney must be swept if it has been previously used for an appliance burning a fuel other than gas
- It is recommended that the chimney be swept before installation of the flexible flue
- Any damper or restrictor plate in the chimney must be removed. If it is not possible to remove the sliding damper it must be fixed permanently in the open position
- Any holes in the chimney must be sealed
- The existing chimney pot and flaunching must be removed
- The catchment space (void below the point of flue connection) must be checked to ensure it complies with the flue to be installed
- All debris must be cleared from the catchment space

Calculating the effective flue length

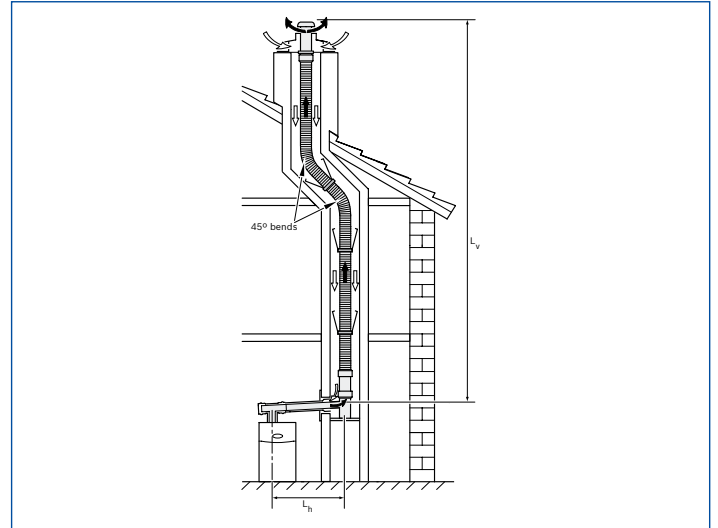

Calculating the effective flue length

Appliance	Max. flue length vertical (L_v max)	Max. flue length horizontal (L_h max)
FS 30CDi	12m	3m
FS 42CDi	12m	3m

To calculate the effective flue length:

- Check the flue path and consider the following:
 - number of 90° and 45° bends required outside the chimney
 - number of bends in the flexible liner
- Deduct the effective length of each bend from the maximum horizontal flue length of 3m

80/125mm bend	Effective length (m)
90°	2
45°	1

- Deduct the effective lengths of each bend from the maximum vertical flue length (L_v max) of 12m.

Bend in 80mm flexible liner	Effective length (m)
45°	1.5

Example of effective flue length calculation

This example shows the use of the flexible flue kit without additional extensions or bends.

Horizontal effective flue length (no extensions or bends)		$L_h \leq L_h$ max ?
$L_h = 1m$	L_h max = 3m	Yes

Vertical effective flue length (with 2 x 45° bends)	L_v
L_v max = 12m - 2 x 45° bends = 3m = (12 - 3)	9m

Plume management terminal positioning

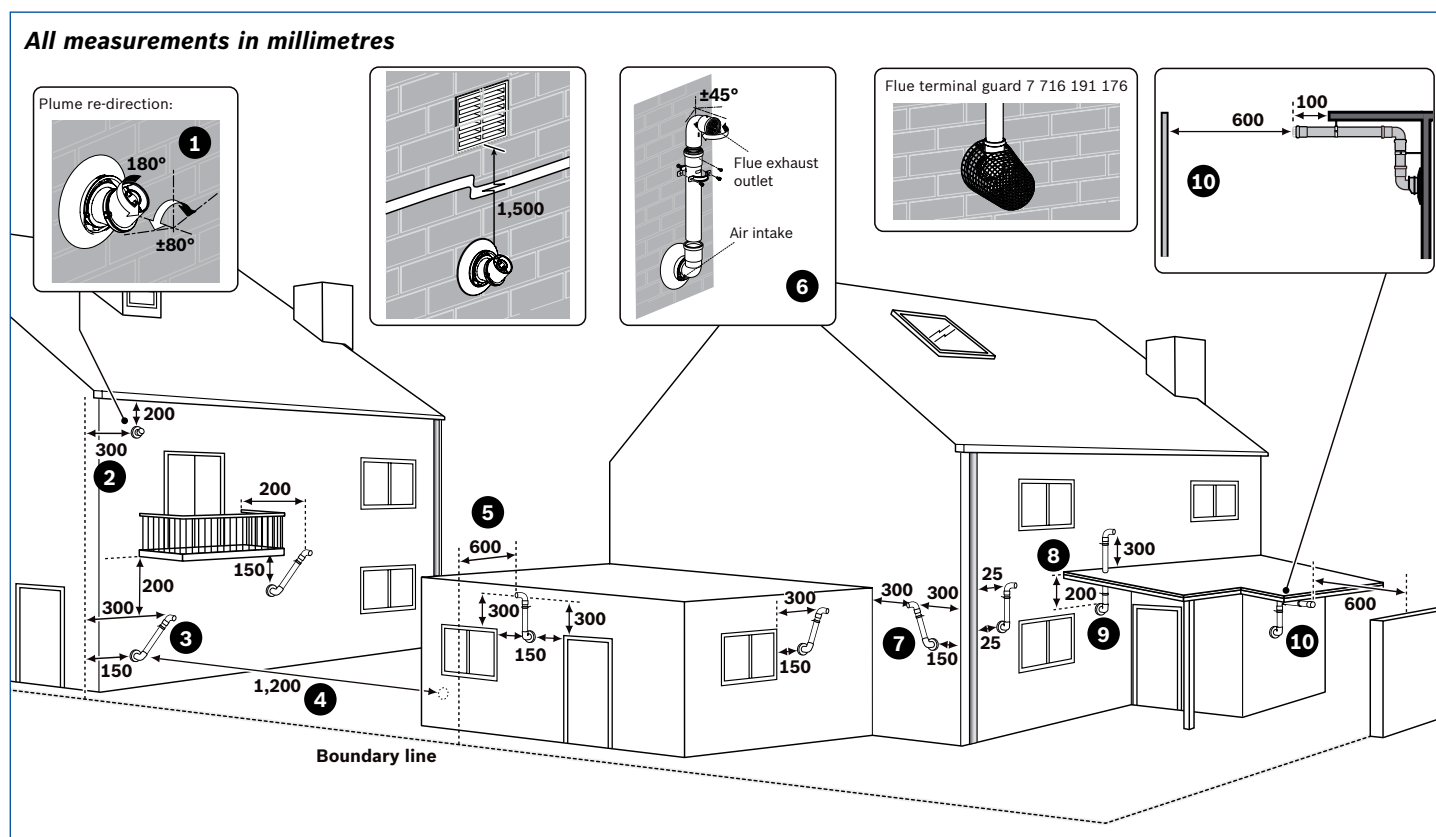

Note

- All measurements are the minimum clearances required
- Refer to pages 34-35 for all concentric flue terminal positions unless the flue position is specified on the figure above “Plume terminal positions”
- Terminals must be positioned so as to avoid combustion products entering the building
- Support the flue at approximately one metre intervals and at a change of direction, use suitable brackets and fittings.

Key to illustration

1. This feature allows some basic plume re-direction options on a standard telescopic horizontal flue terminal. 300mm minimum clearances to an opening, e.g. window. However the minimum clearances to an opening in the direction that the plume management is facing, must be increased to 1,500mm. Where the flue is less than 150mm to a drainpipe, and plume re-direction is used, the deflector should not be directed towards the drainpipe.
 2. 300mm adjacent to a boundary line.
 3. Plume Management Kit air intake can be reduced to 150mm providing the flue exhaust outlet is no less than 300mm adjacent to a boundary line.
 4. 1,200mm between terminals facing each other.
 5. 600mm distance to a boundary line, unless it will cause a nuisance. BS 5440:Part 1 recommends that care is taken when siting terminal in relation to boundary lines.
 6. Using a Plume Management Kit, the air intake measurement can be reduced to 150mm providing the flue exhaust outlet has a 300mm clearance. Plume kits running horizontally must have a 10° fall back to the boiler for proper disposal of condensate. For details on specific lengths see relevant boiler Technical & Specification information.
 7. Internal/external corners. The air intake clearance can be reduced to 150mm providing the flue exhaust outlet has a 300mm clearance.
 8. Clearances no less than 200mm from the lowest point of the balcony or overhang.
 9. 1,200mm from an opening in a car port on the same wall e.g. door or window leading into the dwelling.
 10. 600mm distance to a surface facing a terminal, unless it will cause a nuisance. BS 5440: Part 1 recommends that care is taken when siting terminals in relation to surfaces facing a terminal.
- Installations in car ports are not recommended
 - The flue cannot be lower than 1,000mm from the top of a light well due to the build up of combustion products
 - Dimensions from a flue terminal to a fanned air inlet to be determined.

Plume management system options

Plume management system

60mm dia. plume management kit

- 1 x terminal bend
- 1 x extension 500mm
- 1 x outlet assembly
- 1 x clamp pack

Part No. 7 716 191 086

Accessories



Components	Part No.	Description
60mm diameter		
	7 716 191 086	Plume management kit
	7 716 191 087	Extension (1,000mm)
	7 716 191 088	90° bend
	7 716 191 089	45° bend (pair)
	7 716 191 176	Plume management terminal guard round

Standard plume management system

The flue terminal outlet has built-in stops which limits the rotation for horizontal fluing, allowing the condensate to run back into the boiler for safe disposal. Do not attempt to force beyond the limit stops.

Any plume management extensions as far as the first elbow must rise by at least 173mm per metre (10°). Further subsequent extensions must rise by 52mm (3°) to ensure that condensate flows back to the boiler.

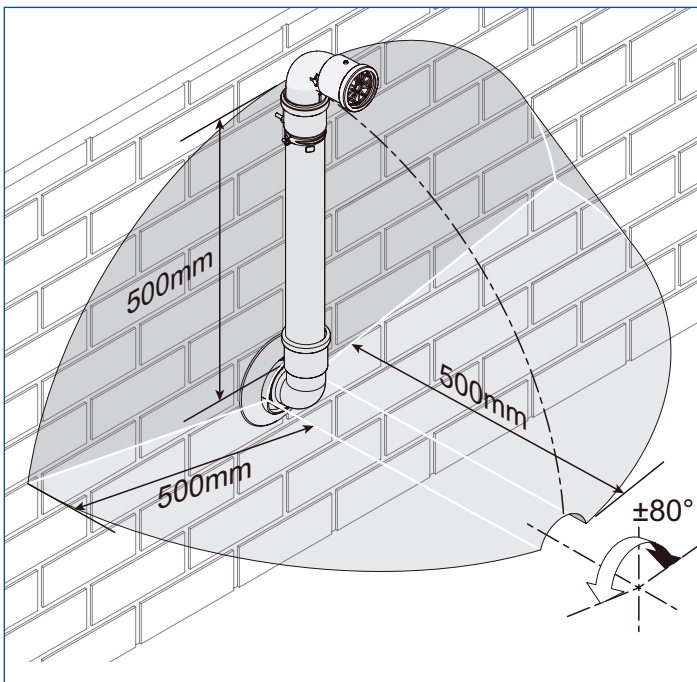

Terminal exclusion zone

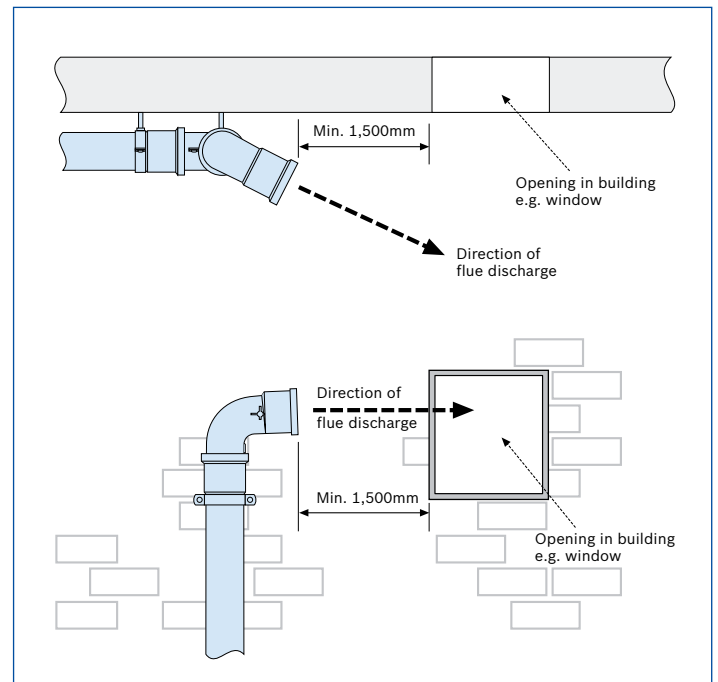

Re-directing flue discharge from a 60mm dia. plume management outlet

The maximum effective flue lengths (L) are stated opposite for the relevant appliance together with the minimum and maximum lengths (M) of the plume management system connected, these lengths must not be exceeded.

External plume management bends still need to be allowed for. See below.

60mm dia. plume management system

To ensure that the maximum total straight flue length along the plume management route is not exceeded, the following should be added to dimension (M):

- 1,500mm for each extra 90° bend
- 750mm for each extra 45° bend

For plume management options with 60mm dia. extensions, refer to page 46.

The effective flue length can be determined by adding together all the straight flue lengths and the effective lengths of the bends used, 2,000mm for each 90° bend and 1,000mm for each 45° bend.

Condensfit II™ telescopic flue and plume management system measuring

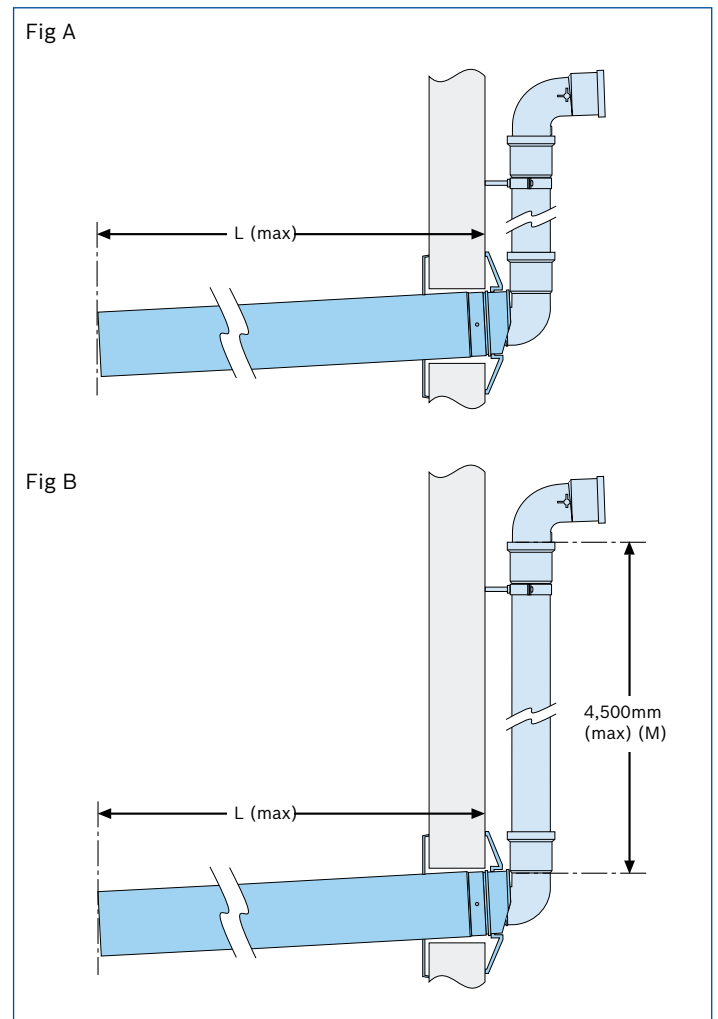

Effective straight flue lengths for telescopic flue with plume management		
Boiler	Fig. A Maximum straight flue length (L) with minimum plume management length 500mm (M)	Fig. B Maximum straight flue length (L) with maximum plume management length 4,500mm (M)
Highflow CDi series	4,000mm	1,200mm
FS CDi Regular series	4,000mm	1,200mm



Plume management system

See terminal exclusion zone diagram on page 44

Components		
Part No. 60mm		7 716 191 086
Maximum lengths (mm) & no. of components required		
Greenstar Highflow CDI & Greenstar FS CDI Regular series*		
60mm	500	1

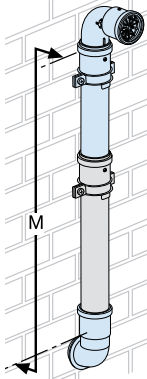

Plume management system with extensions



Components			
Part No. 60mm		7 716 191 086	7 716 191 087
Maximum lengths (mm) & no. of components required			
Greenstar Highflow CDI & Greenstar FS CDI Regular series*			
60mm	4,500	1	up to 4

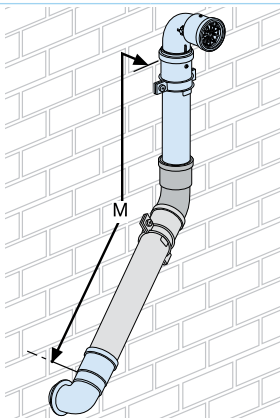

Plume management system with extensions and 45° bend



Components				
Part No. 60mm		7 716 191 086	7 716 191 087	7 716 191 089
Maximum lengths (mm) & no. of components required				
Greenstar Highflow CDI & Greenstar FS CDI Regular series*				
60mm	3,750	1	up to 4	1

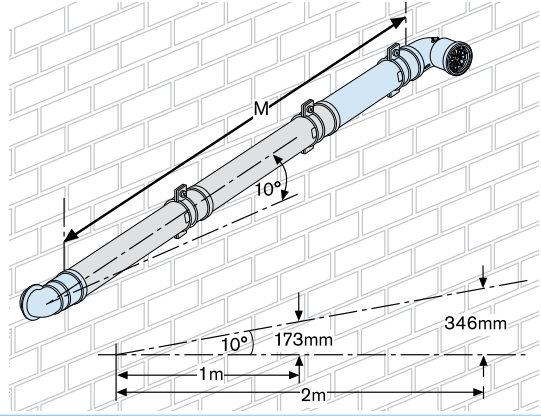

Plume management system with angled termination

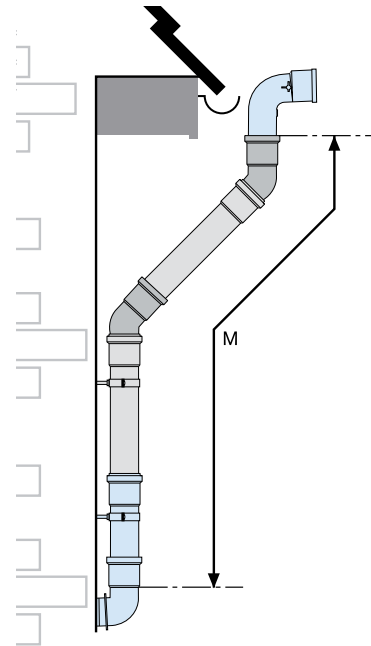

Components			
Part No. 60mm		7 716 191 086	7 716 191 087
Maximum lengths (mm) & no. of components required			
Greenstar Highflow CDI & Greenstar FS CDI Regular series*			
60mm	4,500	1	up to 4

Plume management system with extensions and 45° bends



Components				
Part No. 60mm		7 716 191 086	7 716 191 087	7 716 191 089
Maximum lengths (mm) & no. of components required				
Greenstar Highflow CDI & Greenstar FS CDI Regular series*				
60mm	3,000	1	up to 3	2

*NOTE: You must refer to the table on page 45 to calculate your horizontal flue lengths and plume management lengths.

Greenstar accessories

<p>Standard telescopic flue kit (100mm dia.)</p>  <p>Worcester Part No. 7 716 191 155</p>	<p>Horizontal flue kit (125mm dia.)</p>  <p>Worcester Part No. 7 716 191 157</p>	<p>Vertical BF kit (100mm dia.)</p>  <p>Worcester Part No. 7 716 191 156</p>	<p>Vertical BF kit (125mm dia.)</p>  <p>Worcester Part No. 7 716 191 158</p>
<p>Vertical flue adaptor (60/100mm)</p>  <p>Worcester Part No. 7 716 191 164</p>	<p>Vertical flue adaptor (80/125mm)</p>  <p>Worcester Part No. 7 716 191 165</p>	<p>1,000mm extension kit (100mm dia.)</p>  <p>Worcester Part No. 7 716 191 083</p>	<p>2m flue extension (100mm dia.)</p>  <p>Worcester Part No. 7 716 191 172</p>
<p>Short flue extension 220mm (100mm dia.)</p>  <p>Worcester Part No. 7 716 191 133</p>	<p>1,000mm extension (125mm dia.)</p>  <p>Worcester Part No. 7 719 003 666</p>	<p>45° bend (100mm dia.)</p>  <p>Worcester Part No. 7 716 191 085</p>	<p>45° bend (125mm dia.)</p>  <p>Worcester Part No. 7 719 003 665</p>
<p>90° bend (100mm dia.)</p>  <p>Worcester Part No. 7 716 191 084</p>	<p>90° bend (125mm dia.)</p>  <p>Worcester Part No. 7 719 003 664</p>	<p>Support bracket kit (100mm dia.)</p>  <p>Worcester Part No. 7 716 191 177</p>	<p>Support bracket kit (125mm dia.)</p>  <p>Worcester Part No. 7 716 191 179</p>

**Support bracket kit
6 pack (100mm dia.)**



**Worcester Part No.
7 716 191 178**

**Plume management kit
(60mm dia.)**



**Worcester Part No.
7 716 191 086**

**Extension
(60mm dia., 1,000mm)**



**Worcester Part No.
7 716 191 087**

**90° bend
(60mm dia.)**



**Worcester Part No.
7 716 191 088**

**45° bend
(60mm dia.)**



**Worcester Part No.
7 716 191 089**

**Greenstar System Filter
(22mm)**



**Worcester Part No.
7 733 600 236**

**Greenstar System Filter
(28mm)**



**Worcester Part No.
7 733 600 237**

**Flat roof flashing kit
(100mm & 125mm dia.)**



**Worcester Part No.
7 716 191 090**

**Pitched roof flashing kit
(100mm & 125mm dia.)**



**Worcester Part No.
7 716 191 091**

Greenstar FS CDi Regular series accessories

**80mm flexible
flue system**



**Worcester Part No.
7 716 191 159**

**Greenstore
Unvented Cylinders**



Worcester Part No.

SC-90	7 716 842 027
SC-120	7 716 842 028
SC-150	7 716 842 029
SC-180	7 716 842 030
SC-210	7 716 842 031
SC-250	7 716 842 032
SC-300	7 716 842 033

**Greenstore
Solar Compatible
Unvented Cylinders**



Worcester Part No.

TC-150	7 716 842 040
TC-180	7 716 842 041
TC-210	7 716 842 042
TC-250	7 716 842 043
TC-300	7 716 842 044

Greenstar Highflow CDi series accessories

Comfort plug-in twin channel programmer



**Worcester Part No.
7 733 600 003**

Comfort I RF wireless room thermostat and plug-in twin channel programmer



**Worcester Part No.
7 733 600 001**

Comfort II RF wireless programmable room thermostat and plug-in RF receiver



**Worcester Part No.
7 733 600 002**

Comfort wall mounting plate kit



**Worcester Part No.
7 733 600 039**

Sense I intelligent room thermostat^



**Worcester Part No.
7 738 110 054**

Sense II weather compensation controller



**Worcester Part No.
7 738 111 064**

Wave



**Worcester Part No.
7 716 192 072**

^For use with external proprietary 230V timer only.

Total training experience from Land's End to John O'Groats

Worcester has always been committed to setting the industry standard for expert professional training and this is reflected in the scope and content of the courses, venues and options available.

We offer training on our entire range of domestic and commercial heating technologies as well as industry-led courses. All tuition is handled by expert heating specialists, combining classroom theory with, practical hands-on experience. Keep up-to-date with legislation and experience hands-on-training with our new technologies.

To increase your skills, expertise and value in the market place, trust Worcester's unique and proven total training concept.

Training centres throughout the UK

Worcester

Worcester's award-winning, state-of-the-art Training Academy is an innovative and spacious high tech training arena at our headquarters in Worcester. Facilities include open-plan domestic training areas with life-size single-storey brick buildings. Here installers can get to grips with Greenskies solar thermal systems working with Greenstar gas appliances, clearly demonstrating the importance of system design and operation.

Wakefield

Opened in Summer 2013, the Wakefield Training and Assessment Academy boasts a large gas laboratory which features our entire range of Greenstar gas-fired appliances, a flushing area, wet and dry boilers and a light commercial area with a cascade of Worcester GB162 boilers. There is a solar room with fully working components from our entire Greenskies solar range and a pitched roof for practical training, as well as a large commercial training room.

West Thurrock and Clay Cross

Further academies are located at West Thurrock in Essex and Clay Cross in Derbyshire, both of which offer a comprehensive choice of courses.

College-linked Learning

As well as offering training at our own centres, Worcester has established close partnerships with many colleges around the UK, equipping them with our latest products.

Worcester has worked closely with leading colleges and independent training centres for more than 20 years – a successful enterprise which in 2007 was enhanced further with the launch of the College Links Learning Scheme.

Mobile training

We can also bring training to you. We have mobile vehicles fully equipped with operational Greenstar gas-fired boilers, dry strip-down models and even a Greensource air to air heat pump. Our 7.5 tonne mobile oil vehicle is also available for hands-on oil product training and OFTEC assessments.

Call now for more information 0330 123 0166.



Gas-fired product courses

As a market leader in gas-fired condensing boilers, we aim to ensure the highest levels of competence and expertise in the installation of all Worcester Greenstar gas-fired products. We run intensive training courses for installers, commissioning engineers and operatives involved with servicing and fault finding.

Our comprehensive gas-fired condensing boiler training courses include product overview, inspection and cleaning of components, CO and CO₂ analysis of flue gas, removal of compact hydraulics, service mode functions and fault finding on 'live and demo' appliances.

Gas-fired condensing boiler courses

- **Greenstar CDi Classic gas-fired condensing combi boilers.**
- **Greenstar CDi Compact and Greenstar Si Compact gas-fired condensing combi boilers.**
- **Greenstar i gas-fired condensing combi boilers.**
- **Greenstar system & regular gas-fired condensing boilers.**
- **Greenstar Highflow CDi & FS CDi Regular floor standing gas-fired condensing combi and regular boilers.**
- **Greenstar Controls** (covers MT10, MT10RF, Greenstar Comfort range, Wave internet connected room thermostat, NEW Greenstar Sense range and solar controls).

	Greenstar Overview	CDi Classic	CDi Compact & Si Compact	Greenstar i	System & Regular	Highflow CDi & FS CDi Regular	Controls
Duration	1 Day	1 Day	1 Day	1 Day	1 Day	1 Day	1 Day
Cost	Free*	Free*	Free*	Free*	Free*	Free*	Free*
Training course covers							
Specification	✓	✓	✓	✓	✓	✓	Guide to the varied range of control options that are available
Installation	✓	✓	✓	✓	✓	✓	
Commissioning	✓	✓	✓	✓	✓	✓	
Servicing	✓	✓	✓	✓	✓	✓	
Maintenance	✓	✓	✓	✓	✓	✓	
Course locations							
Worcester	✓	✓	✓	✓	✓	✓	✓
Clay Cross	✗	✗	✗	✗	✗	✗	✓
Wakefield	✓	✓	✓	✓	✓	✓	✓
West Thurrock	✓	✓	✓	✓	✓	✗	✗
College Links†	✓	✓	✓	✓	✓	✗	✓
Mobile†	✓	✓	✓	✓	✗	✗	✓

*A holding fee of £65 applies to free courses and is refunded on attendance of the course. If a booking is cancelled more than 10 working days before the course date, the fee will be fully refunded. The fee is non-refundable if a cancellation is made less than 10 working days before the course date.

†Please contact Worcester Training for specific colleges and mobile dates.



Additional product and industry training courses

The diversity of products in today's heating industry gives you the opportunity to expand your expertise, whilst offering more choice to your customers. Worcester provides comprehensive training from all its academies on its entire range of technologies. Call us on **0330 123 0166** to order a full course training brochure or to book yourself onto a training course, alternatively, you can visit worcester-bosch.co.uk/training

Oil-fired product courses

- Greenstar Danesmoor & Heatslave II high efficiency condensing oil-fired boilers.
- Oil advanced fault finding.
- OFTEC 50.
- OFTEC 101/105e, OFTEC 600a and OFTEC 101/105e/600a.

Renewable product courses

- Renewables overview.
- Greenskies solar.
- Greenskies advanced solar.
- Introduction to heat pumps.
- Greenstore ground source heat pumps.
- Greensource air to air heat pumps.

Worcester commercial product courses

- Greenspring CWi47 water heater.
- GB162 overview.
- GB162 domestic.
- GB162 commercial.
- Greenstar Heat Distribution Unit.
- Commercial ACS training and assessment – CODNCO1.

Bosch commercial product courses

- GB312 & GB402 overview.
- Solar thermal product overview.
- GWPL Gas Absorption Heat Pumps overview.
- CHP overview.
- Commercial controls overview.

Industry focused courses

- Hot water systems & safety.
- Chemical water treatment.
- Construction skills F-Gas training/assessment certification.
- Domestic ACS training and assessment – reassessment. CCN1 + 3 appliances.
- QCF Level 3 Award
 - Air source and ground source heat pumps.
 - Air to water and split air to water heat pumps.
 - Solar thermal.
- MCS Made Easy.
- LPG Changeover.
- WRAS Water Regulations.



A complete after-sales service

As part of the worldwide Bosch Group, Worcester strives to maintain the highest possible standards of after-sales care.

Worcester Contact Centre

Should you require support, our award winning Contact Centre team, based at our head office in Worcester, are ready to take your calls. Whatever your query our contact centre operators along with our nationwide team of engineers are ready to help you.

Tel: 0330 123 9559

Opening times

Monday – Friday: 7.00am – 8.00pm

Saturday: 8.00am – 5.00pm

Sunday: 9.00am – 12 noon

Bank Holidays: 8.00am – 4.30pm



Spares

Genuine replacement parts for all supported Worcester products are readily available from stock, or on a next day delivery basis. Visit worcester-bosch.co.uk/spares to find your local stockist.

Customer Technical Support

The Worcester Technical Helpline is a dedicated phone line – committed to providing a comprehensive service to complement the brand name and quality of our products. Our experienced team of technical experts provides answers to queries of a technical nature across the entire Worcester range.

Technical Support

Tel: 0330 123 3366

Fax: 01905 752 741

Email: technical-advice@uk.bosch.com

Opening times

Monday – Friday: 7.00am – 8.00pm

Saturday: 8.30am – 4.00pm

Bank Holidays: 8.00am – 4.30pm

ErP Technical Helpline

Tel: 0330 123 3641

Email: ErP-advice@uk.bosch.com



Expand your business with **Bosch Commercial and Industrial**



Located at Worcester's headquarters, Bosch Commercial and Industrial provides the heating, hot water and air conditioning solutions for the commercial and industrial market.

Bosch Commercial and Industrial offers an extensive product range which deliver high levels of fuel efficiency, consistent heating and hot water performance and have a long product life.

All Bosch products are subject to rigorous quality testing of each and every component, to ensure efficient, reliable and consistent performance throughout their long life.

These products are supported by an unrivalled commercial technical support team which is able to provide advice on product specification and installation queries.

From initial consultation to final commissioning, Bosch offers the complete package. Added peace of mind comes from secure guarantees and 10 year spares availability.

Growing your business with Bosch

The products and support services you can access gives you the chance to expand your business offering and provide installations for:

- ▶ Large domestic properties
- ▶ Hotels, guest houses & holiday parks
- ▶ Sports and leisure centres
- ▶ Education and healthcare facilities
- ▶ Mini district heating schemes
- ▶ And many more...



BOSCH

Invented for life

Offering a broad portfolio that covers almost all heating requirements:

- ▶ Gas- or oil-fired boilers with individual outputs from 50kW to 38,000kW and standard efficiencies of up to 109%
- ▶ Compact condensing multi-boiler cascade systems of wall-mounted boilers (400kW in just 1m²)
- ▶ Compact condensing multi-water heater cascade systems of wall-mounted water heaters (up to 600kW)
- ▶ Air conditioning solution with a comprehensive Variable Refrigeration Flow (VRF) range
- ▶ Combined heat and power (CHP) modules with output ranging from 12kWe to 2MWe
- ▶ All products are compatible with a complete range of intelligent controls and accessories.

Large-scale efficiency: heating systems

- ▶ Reliable heat supply and hot water provision for healthcare requirements
- ▶ Tailored, flexible solutions for highly efficient and eco-friendly boiler operation
- ▶ Our controls are designed to maximise the heating system's efficiency, while allowing the facilities manager to gain quick and easy access to all functions of the boiler and the heating system
- ▶ Simple planning, installation and commissioning of the entire system thanks to modular components.

Commercial ACS training

With Worcester, Bosch Commercial and Industrial runs certified commercial ACS courses equipping installers with the relevant qualifications for the changeover from domestic to commercial gas work.

Our technical training officers, who have many years' experience as heating technicians, combine practical installation tips with heating theory and legislative requirements, ensuring a thorough understanding of all aspects.

Heating and hot water solution



Air conditioning solutions



For more information please call **0330 123 3004** or visit **bosch-industrial.co.uk**

 Bosch Commercial and Industrial UK

 @BoschHeating_UK

Useful numbers

Sales

Tel: 0330 123 9669
sales.mailbox@uk.bosch.com

Spare Parts

Tel: 0330 123 9779
spares.mailbox@uk.bosch.com

Technical Helpline (Pre & Post Sales)

Tel: 0330 123 3366
technical-advice@uk.bosch.com

ErP Technical Helpline

Tel: 0330 123 3641
ErP-advice@uk.bosch.com

Training

Tel: 0330 123 0166
training@uk.bosch.com

Literature

Email: brochure-request@uk.bosch.com
or download instantly from our website
or telephone 0330 123 9119

Customer Service

Service Enquiries

Email: service-enquiries@uk.bosch.com
or telephone 0330 123 9559

Guarantee Registration

To register your Worcester
guarantee, please visit our website
worcester-bosch.co.uk/guarantee,
download our guarantee
registration app or
telephone 0330 123 2552

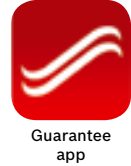

Share

We would love to see your installations. Follow us on:



@WorcesterBosch

Tag your installations with: #WarmAtHeart



facebook.com/WorcesterBoschProfessional

We are also on:



Calls to and from Bosch Thermotechnology Ltd may be recorded for training and quality assurance purposes.

worcester-bosch.co.uk



CIPHE

In partnership with



energy saving trust™

HHIC
HEATING & HOTWATER INDUSTRY COUNCIL



Worcester, Bosch Group is a brand name of Bosch Thermotechnology Ltd.

This leaflet is accurate at the date of printing, but may be superseded and should be disregarded if specification and/or appearances are changed in the interest of continued improvement. The statutory rights of the consumer are not affected. Apple is a trademark of Apple Inc., registered in the U.S. and other countries. App Store is a service mark of Apple Inc. Google Play and Android are trademarks of Google Inc.



Sustainable Forests



Totally Chlorine Free

WORCESTER
Bosch Group

Worcester, Bosch Group,
Cotswold Way, Warndon,
Worcester, WR4 9SW



Part No. 8 716 106 250 M 05/16