

CT XTRA RANGE

An innovative range of single and twin ended shower pumps. The CT Xtra range raises the bar for all other 'entry level' shower pumps to follow. Designed to quietly and efficiently boost the hot and cold water supplies to the thermostatic or manual mixer valves and are suitable for a wide range of shower types and heads, these pumps will increase flow to any tank fed appliances making them the best value for money pumps available.

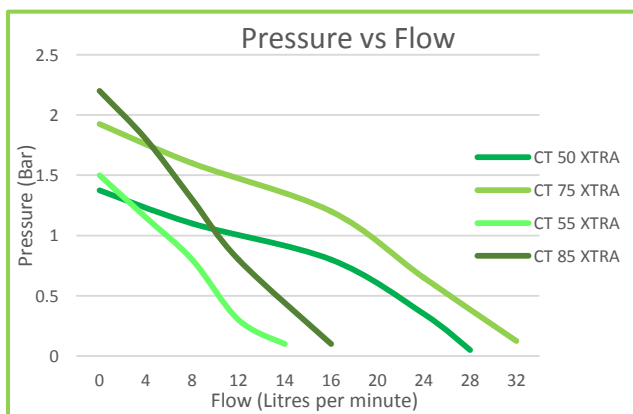

- 1.5, 2.0, 2.5 bar performance options
- Compact size
- Very quiet
- Compact seal
- Continuously rated
- Fully automatic
- 15mm push fit flexible hoses with integral isolating valves on inlets
- Pre-wired with 1.25 metre power cable
- Anti-vibration feet
- 2 year warranty

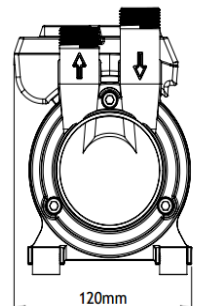
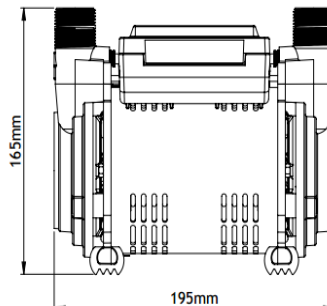

CT XTRA Technical Specification

Part No.	Description	Specification			Performance			Connection Type			Pump Volumetrics				Packed Pump Volumetrics			
		Electrical Input	Fuse	Pump Type	Pressure (kPa/Bar) at 16ltr/min	Pressure (kPa/Bar) at 8ltr/min	Max pressure (kPa/Bar) closed head	Pump	Hoses	Isolators	Dimensions				Dimensions			
		230/1/50		Regenerative				BSP	Push fit	Isolators integrated into the hoses	Weight (kg)	Length (mm)	Width (mm)	Height (mm)	Weight (kg)	Length (mm)	Width (mm)	Height (mm)
CT Xtra Shower Pumps																		
CT 50 Xtra	1.5 Bar Twin End Positive Head Shower Pump	✓	3A	✓	120 (1.2)	140 (1.4)	150 (1.5)	¾"	15mm	✗	3.46	195	120	165	4.22	295	215	205
CT 50+ Xtra	1.5 Bar Twin End Positive Head Shower Pump	✓	3A	✓	120 (1.2)	140 (1.4)	150 (1.5)	¾"	15mm	✓ Inlet Only	3.46	195	120	165	4.22	295	215	205
CT 75 Xtra	2.0 Bar Twin End Positive Head Shower Pump	✓	3A	✓	150 (1.5)	170 (1.7)	200 (2.0)	¾"	15mm	✗	3.78	195	120	165	4.55	295	215	205
CT 75+ Xtra	2.0 Bar Twin End Positive Head Shower Pump	✓	3A	✓	150 (1.5)	170 (1.7)	200 (2.0)	¾"	15mm	✓ Inlet Only	3.78	195	120	165	4.55	295	215	205
CT 55 Xtra	1.5 Bar Single End Positive Head Shower Pump	✓	3A	✓	120 (1.2)	140 (1.4)	150 (1.5)	¾"	15mm	✗	3.37	195	120	165	4.01	295	215	205
CT 55+ Xtra	1.5 Bar Single End Positive Head Shower Pump	✓	3A	✓	120 (1.2)	140 (1.4)	150 (1.5)	¾"	15mm	✓ Inlet Only	3.37	195	120	165	4.01	295	215	205
CT 85 Xtra	2.5 Bar Single End Positive Head Shower Pump	✓	3A	✓	200 (2.0)	230 (2.3)	250 (2.5)	¾"	15mm	✗	3.38	195	120	165	4.02	295	215	205
CT 85+ Xtra	2.5 Bar Single End Positive Head Shower Pump	✓	3A	✓	200 (2.0)	230 (2.3)	250 (2.5)	¾"	15mm	✓ Inlet Only	3.38	195	120	165	4.02	295	215	205

