



FloPlast

building the future

FloPlast Limited
Castle Road
Eurolink Business Park
Sittingbourne
Kent ME10 3FP
UK

Tel: +44 (0)1795 431731

Fax: +44 (0)1795 431188

**Sales Office Direct Line:
+44 (0)1795 421422**

Email: sales@floplast.co.uk

Website: www.floplast.co.uk


FloPlast Air Admittance Valves

(Issue 1, 09/2007)

Vanne d'adduction d'air

Clapets d'admission d'air pour systems d' evacuation

Luft Zulassung Ventil

This document relates to FloPlast's AF32, AF110, AVE100 and AV110. The valves have been designed for above-ground use in conjunction with Building Regulations, (PART H1) and systems designed in accordance with this document. FloPlast's Air Admittance Valves carry the British Standards Institution (BSI) Kitemark  (KM512474), as having met the performance requirements of BS EN 12380: 2002 and have been designated with an A1 rating.

FloPlast's Air Admittance Valves provide a means of ventilation to the drainage system to prevent the loss of water seals in traps and consequent release of foul air into the building.

The drainage system, installation and use of FloPlast's Air Admittance Valves must be in accordance with the design data and installation sections of this document.



AF32



AVE100/AV110



AF110

**PVC-UE Roofline,
Window &
Cladding Systems**

**Rainwater
Systems**

**Soil & Waste
Systems**

**Underground
Drainage
Systems**

**MDPE
Systems**

**Hot & Cold
Plumbing
Systems**



1. Product and Technical Specification

1.1 AF32: The AF32 has been designed for installation directly onto 32mm UK designated Solvent Waste pipe. With the use of the universal adaptor (provided with the product), the AF32 can also be installed onto 40mm and 50mm UK designated pipe. The valve is also available designated as AFE32, which has been designed for use with European designated 32mm/40mm and 50mm Solvent Waste pipe.

FloPlast's AF32 Air Admittance Valve, (as seen on front cover) comprises of an injection-moulded, two-part acrylonite butadine styrene (ABS) body, snapped together incorporating an ethylene propylene diene monomer (EPDM) sealing ring. The valve incorporates a sliding ABS injection moulded disc and EPDM seal (poppet) which acts as the opening and closing seal.

1.2 AV110/AVE100: The AV110 has been designed for installation directly onto 110mm UK designated pipe. The AVE100 valve has been designed for use with European designated 100mm pipe.

FloPlast's AV110/AVE100 Air Admittance Valve, (as seen on front cover) comprises an injection-moulded, two-part poly vinyl-chloride (PVC-U) body, screwed together incorporating an EPDM sealing ring. The valve incorporates a sliding ABS injection moulded disc and EPDM seal (poppet) which acts as the opening and closing seal.

1.3 AF110: The AF110 has been designed for installation directly into 110mm UK designated pipe with the use of an EPDM finned seal. Additionally the AF110 can be installed directly onto 82mm designated pipe. The valve can also be installed directly into 100mm or 110mm European designated pipe with the use of an EPDM finned seal, this product is designated AFE110.

FloPlast's AF110 Air Admittance Valve, (as seen on front cover) comprises of an injection-moulded, two-part poly vinyl-chloride (PVC-U) body, screwed together incorporating an EPDM sealing ring. The valve incorporates a sliding ABS injection moulded disc and EPDM seal (poppet) which acts as the opening and closing seal.

1.4 The valves incorporate spigots detailed in Table 1. They incorporate a finned seal for installation into 110mm and 100mm pipes or ABS and PVC-U solvent sockets.

1.5 The valves incorporate spigots with diameters that are in accordance with the standards for waste pipe, including: BS EN 1329-1: 2000, BS EN 1455-1: 2000, BS5255: 1989 and BS 4514: 2001.

1.6 Continuous quality control is exercised during their manufacture and assembly, including visual checks, checks on dimensional accuracy and 100% functional testing of each product. The raw materials and bought-in goods are subject to quality controls as defined within our ISO9001 Quality Management System (FM 501414) audited by BSI.

PVC-UE Roofline,
Window &
Cladding Systems

Rainwater
Systems

Soil & Waste
Systems

Underground
Drainage
Systems

MDPE
Systems

Hot & Cold
Plumbing
Systems

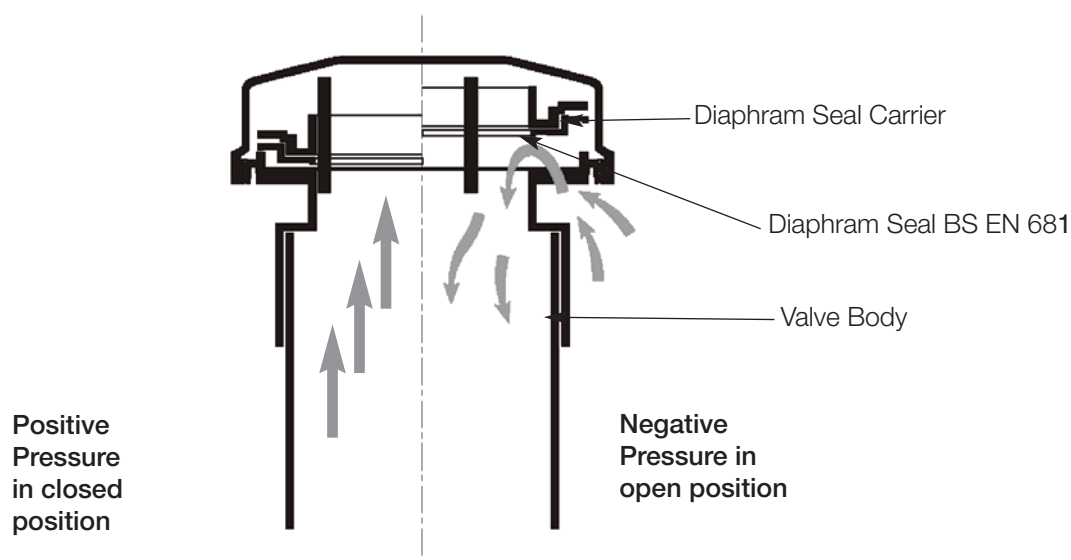


1.7: Table 1 Product Range

Valve Size (nominal socket diameter or fin seal designation)	Product Code	BS EN 12380 Designation	Use
UK designated sizes			
32mm	AF32	A1	See section 4.2
40mm	AF32	A1	See section 4.2
50mm	AF32	A1	See section 4.3
82mm	AF110	A1	See section 4.4
110mm – Push Fit	AF110	A1	See section 4.4
110mm Solvent Cement	AV110	A1	See section 4.4
European designated sizes			
32mm	AFE32	A1	See section 4.2
40mm	AFE32	A1	See section 4.2
50mm	AFE32	A1	See section 4.3
100mm & 110mm – Push-Fit	AFE110	A1	See section 4.4
100mm Solvent Cement	AVE100	A1	See section 4.4

A1 = permitted to be used below flood level in locations where the temperature is in the range of -20°C to +60°C.

2. Figure 1 FloPlast Air Admittance Valve Functioning



3. Delivery and Site Handling

3.1 Valves, complete with their adaptors (when applicable), along with installation instructions are supplied in cardboard boxes and polyethylene bags, to limit the risk of contamination or damage. All valves must be stored upright in their boxes until required for use.

3.2 The legend of the distributor is incorporated on to the lid of the product and is shown on the packaging. In addition, all FloPlast valves have CE mark designation A1 to BS EN 12380: 2002, the details of which appear on the boxes.

PVC-UE Roofline,
Window &
Cladding Systems

Rainwater
Systems

Soil & Waste
Systems

Underground
Drainage
Systems

MDPE
Systems

Hot & Cold
Plumbing
Systems



4. Design Data



4.1 The FloPlast Air Admittance Valves when used in above-ground drainage systems designed with BS 12056-1: 2000 and BS 12056-2: 2000 will:

- Admit air under conditions of reduced pressure in the discharge pipes and prevent water seals in traps from being drawn or evacuated.
- Prevent the release of foul air from the drainage system.
- Contribute to the ventilation of the main drain to which the discharge stack incorporating the valve is connected.

4.2 The 32mm and 40mm valves are designed for connection to waste pipes to prevent water loss from trap seals by self and induced siphonage arising from water flow in small diameter branch discharge pipes.

4.3 The 50mm valve is for use on branch discharge pipes.

4.4 The 82mm, 100mm and 110mm valves are designed for use on discharge stacks up to 45 metres or 10 storeys high.

4.5 The FloPlast valves are designed for use in association with each other or separately.

5. Drainage System Design



5.1 Drainage systems designed in accordance with BS EN 12056-1: 2000 and BS EN 12056-2: 2000 should be based on the airflow data given in Table 2. Typical installation details in accordance with BS EN 12056-1: 2000 are given in Figures 2 and 3.

Table 2 Airflow Performance (litres per sec)

Nominal size of pipe	Airflow
32mm	6.5
82mm/110mm	43.0

Note: These results are based on tests carried out by the United Kingdom Building Research Establishment (BRE) in accordance with BS EN 12380: 2002

5.2 To contribute to the ventilation of the underground drain and to minimise the effects of excessive back pressures when a drain blockage occurs, the branch or main drain serving a stack or stacks fitted with a FloPlast valve may require a venting point upstream of the stack connection. For guidance the following should be noted (see figure 4):

- For up to and including four dwellings, one, two or three storeys in height, additional drain venting is not required. Where a drain serves more than four such dwellings equipped with the valve, the drain should be vented according to the following rule, either by a conventional open-topped ventilation or discharge stack:
 - 5 to 10 such dwellings – conventional ventilaton to be provided at the vent stack furthest from the main drain.
 - 11 to 20 such dwellings – conventional ventilation to be provided at the vent stack furthest from the main drain and at the mid-point of the system.

PVC-UE Roofline,
Window &
Cladding Systems

Rainwater
Systems

Soil & Waste
Systems

Underground
Drainage
Systems

MDPE
Systems

Hot & Cold
Plumbing
Systems



- For multi-storey domestic dwellings (other than those referred to above) and non-domestic buildings, conventional drain venting should be provided if more than one such building (each equipped with the valves) is connected to a common drain which is not itself vented by means of a ventilation stack or a discharge stack which is not fitted with a valve.

5.3 To prevent self-siphonage a connection to the AF32 valve is required within 1500mm of the trap (see Figure 3).

5.4 To prevent induced siphonage in a row of wash-basins, a AF32 valve can be fitted between the two washbasins furthest away from the discharge stack (see Figure 3).



5.5 Air admittance valves should not be used as the only ventilation to septic tanks or cesspools.



5.6 The valve should be installed within the building where it is easily accessible but not subject to interference from vandals.

5.7 If the valve is to be installed in, or in close proximity to, a habitable space where noise of operation may cause a nuisance, then consideration must be given to the use of a suitable form of sound insulation.

5.8 In addition, other than those shown in Figure 4, stacks should not be fitted with the valves when the connecting drain(s) are subject to periodic surcharging or are fitted with intercepting traps. An open-topped discharge stack or ventilating stack should be used in such cases.

6. Effects on Water Seals



6.1 The valves will admit sufficient quantities of air into the stack when they are subjected to a reduced pressure and there by prevent loss of the water seals in appliance traps.

6.2 Under conditions of increased pressure in the drainage system, each valve will remain closed, thereby preventing the release of foul air into the building.

6.3 A pressure increase sufficient to raise the level in the water seal or to cause foul air to bubble up through the seal is an indication that either a drain blockage has occurred, the system is being overloaded or otherwise misused.

7. Maintenance

7.1 FloPlast valves do not normally require maintenance.

7.2 In the event of accidental damage or vandalism the FloPlast valves must be renewed.

PVC-UE Roofline,
Window &
Cladding Systems

Rainwater
Systems

Soil & Waste
Systems

Underground
Drainage
Systems

MDPE
Systems

Hot & Cold
Plumbing
Systems



8. Durability




FloPlast valves are manufactured from materials conventional in drainage systems. Repeated opening and closing will not adversely affect the sealing or operation of the valve. When used in the context of this data sheet the product will not be subject to significant deterioration and will have a life equivalent to that of the drainage system in which it is installed.

9. Regulations

9.1 The Building Regulations 2000 (as amended) (England and Wales)



The Secretary of State has agreed the requirements of the Building Regulations to which Air Admittance Valves can contribute in achieving compliance. By demonstrating that the products detailed within this document have achieved the Kitemark  against BS EN 12380: 2002 with a designation A rating by BSI, used in the context of this document, will contribute to meeting the relevant requirements.

Requirement:	H1	Foul water drainage
Comment:		FloPlast valves will: <ol style="list-style-type: none"> (1) Provide adequate ventilation to prevent the loss of water seals in trapped appliances. See sections 4.1 to 4.4, 5.1 to 5.9 and 6.1 to 6.3 of this document. (2) Prevent foul air from entering the building. See 6.2 of this document. (3) Enable access to sanitary pipework for cleaning blockages. See section 5.1 of this document. (4) Contribute to the ventilation of underground drains. See section 5.2 and 5.3 of this document.
Requirement:	Regulation 7	Materials and workmanship.
Comment:		The products are acceptable. See section 8 of this document.

9.2 The Building Standards (Scotland Regulations) (2004 as amended)



FloPlast Air Admittance Valves, if used in accordance with the provisions of this document, will satisfy the various Regulations and related Technical Standards as listed below.

Regulation:	8	Fitness and durability of materials and workmanship.
Regulation:	8(1)	Fitness and durability of materials and workmanship.
Comment:		The products can contribute to a construction when meeting this standard. See section 10 of this document.
Regulation:	9	Building standards - construction.
Standard:	3.7(b)(c)	Wastewater drainage.
Comment:		The FloPlast valves can meet the relevant requirements of the standards. See sections 4.1 to 4.4, 5.1 to 5.4, 5.6 to 5.8 and 6.1 to 6.3 of this document.



9.3 The Building Regulations (Nothern Ireland) 2000 (as amended)



The FloPlast Air Admittance Valves, if used in accordance within the provisions of this document, will satisfy the various Building Regulations as listed below.

Regulation:	B2	Fitness of materials workmanship
Comment:		The products are acceptable. See section 10 of this document
Regulation:	N2	Drainage Systems
Comment:		The valves provide adequate ventilation to prevent the destruction of the water seals in traps. See sections 4.1 to 4.4, 5.1 to 5.4, 5.6 to 5.8 and 6.1 to 6.3 of this document.

9.4 Construction (Design and Management) Regulations 2007 (as amended) Construction (Design and Management) Regulations (Nothern Ireland) 2007

There is no information in this document which relates to the obligation to the client, planning supervisor, designer and contractors under these regulations.

10. Installation

10.1 Installation must be carried out in accordance with these instructions.

10.2 FloPlast AF110 valves are supplied with a synthetic rubber connector enabling a push-fit into 100mm and 110mm PVC-U pipes to BS4514: 2001 and BS EN 1329-1: 2000. Additionally if the rubber connector is removed from the valve a solvent cement socket will be revealed enabling connection to 82mm PVC-U pipes to BS4514: 2001.

10.3 FloPlast AV110 and AVE100 are available in both UK and European designated sizes respectively, supplied with solvent cement sockets enabling a solvent cement connection to PVC-U pipes to BS4514: 2001 and BS EN 1329-1: 2000.

10.4 FloPlast AF32 valves are available in both UK and European designated sizes, supplied with a solvent weld socket on the main body for 32mm with an adaptor enabling the product to be connected to solvent welded PVC-U and ABS pipe to BS EN 1329-1: 2000, BS EN 1455-1: 2000, BS5255: 1989.

10.5 FloPlast AVE100, AV110 and AF110 valves must be fitted in a vertical position a minimum of 200 mm above the highest branch connection (see Figure 3). As FloPlast valves are A1 designated to BS EN 12380-1: 2002 it is possible to locate them below the lowest reservoir being vented.

10.6 FloPlast AF32 valves must be fitted in a vertical position a minimum of 100mm above the pipe being vented. As FloPlast valves are A1 designated to BS EN 12380-1: 2002 it is possible to locate them below the lowest reservoir being vented.

10.7 The valves are easily installed in discharge and/or ventilation pipes and eliminate the need to penetrate the roof covering. Care should be taken to avoid contamination of the sealing surfaces, as this may affect airtightness.

PVC-UE Roofline,
Window &
Cladding Systems

Rainwater
Systems

Soil & Waste
Systems

Underground
Drainage
Systems

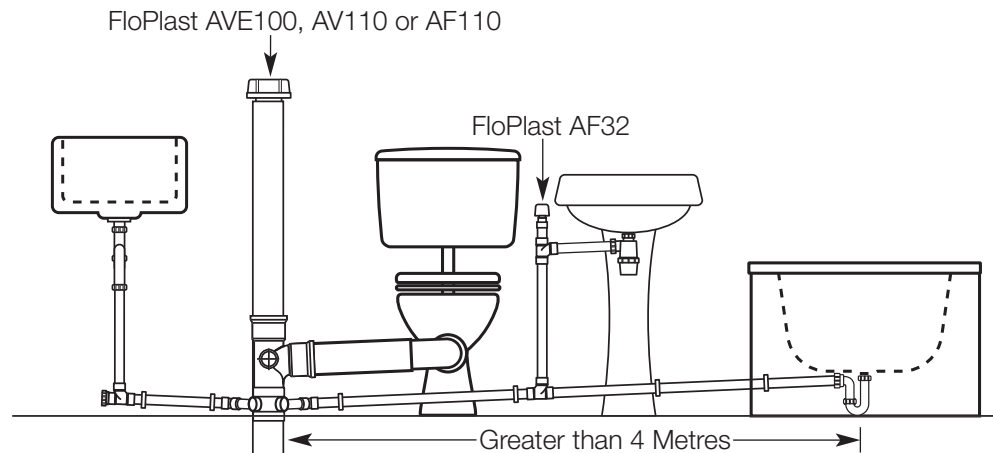
MDPE
Systems

Hot & Cold
Plumbing
Systems

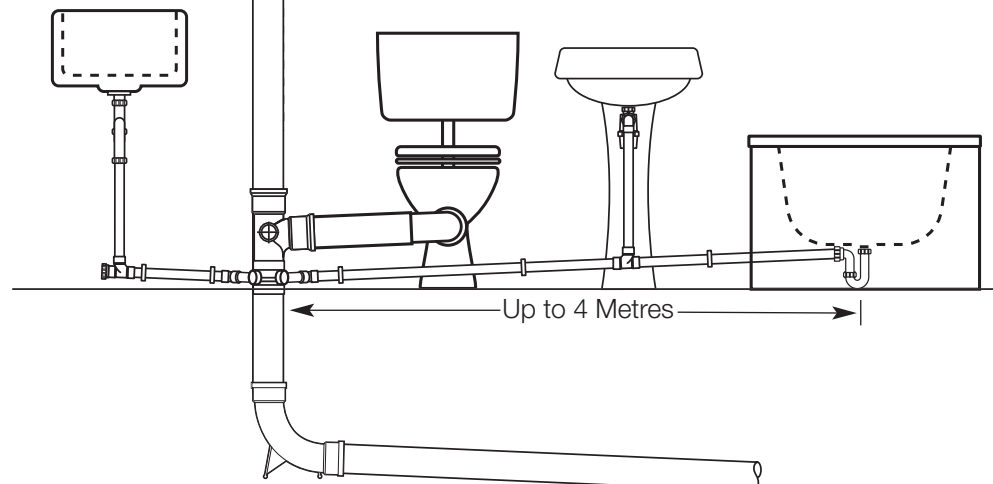


Figure 2 Valves installed in domestic dwellings

(a) Ventilated by FloPlast AVE100, AV110 or AF110



(b) Unventilated



NOTES:

- The maximum distance of appliance traps from the discharge stack must be in accordance with BS EN 12056-2: 2000 paragraph 6.4.3 Table 10 and Figure 9 Ventilated Branches. The separate ventilation shown on the BS figures may be provided by a FloPlast AF32 Air Admittance Valve which must be within 1.5 metres of the appliance trap.
- Unventilated branches BS EN 12056-2: 2000 paragraph 6.4.11, Table 5 and Figure 6.
- Ventilation stacks higher than 45 metres or 10 storeys must not be fitted with the FloPlast AV110/AF110 Air Admittance Valve.



Figure 3 FloPlast Air Admittance Valve Functioning

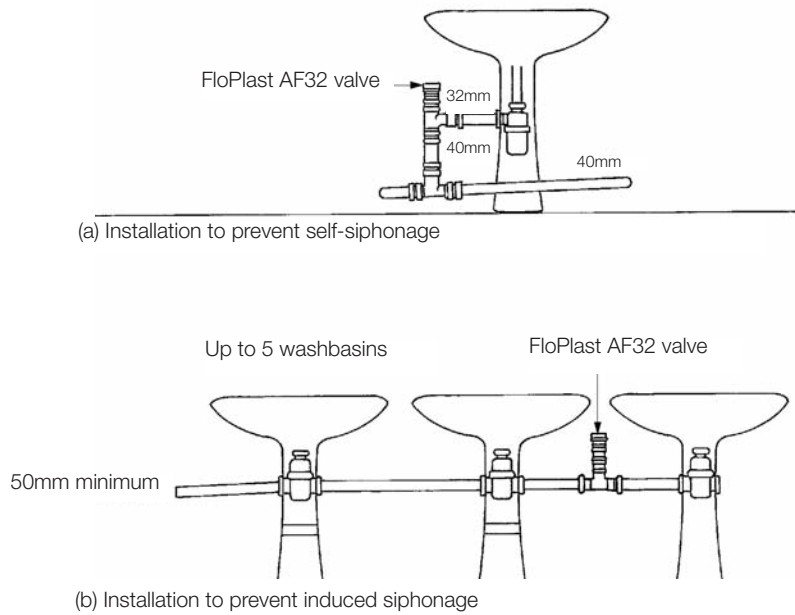
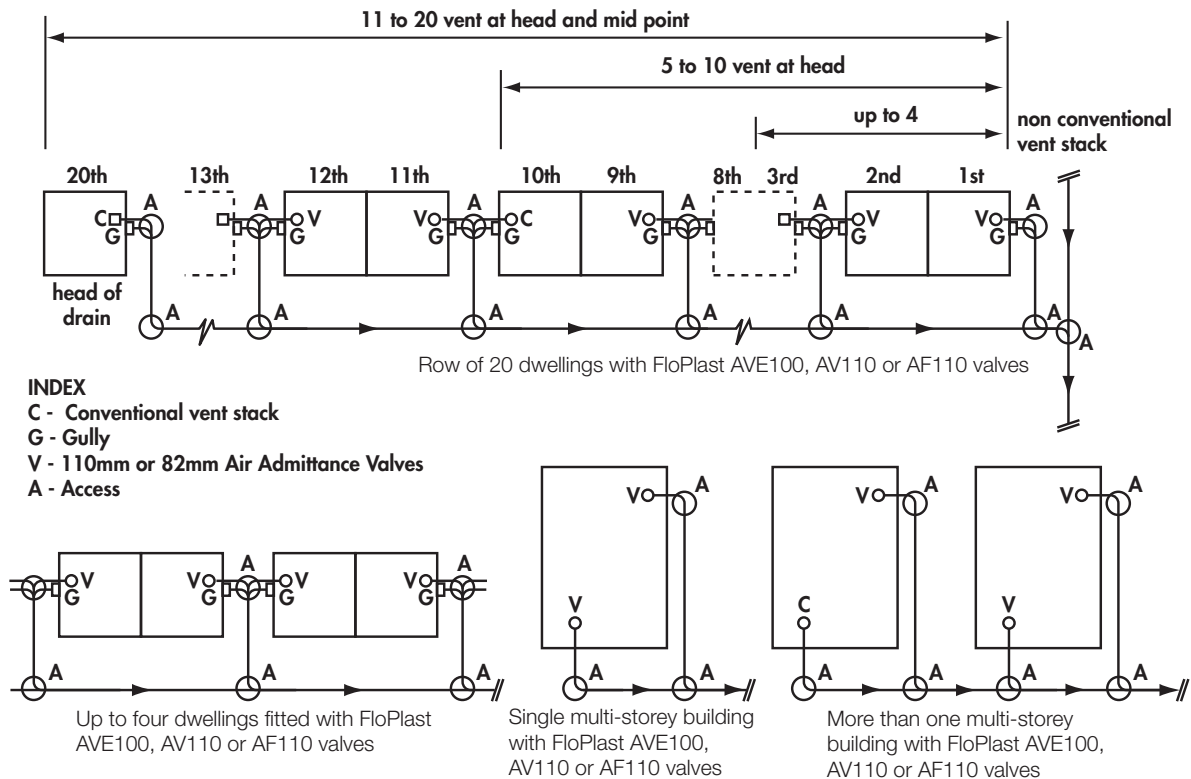


Figure 4 Examples Of Drain Ventilation Provisions

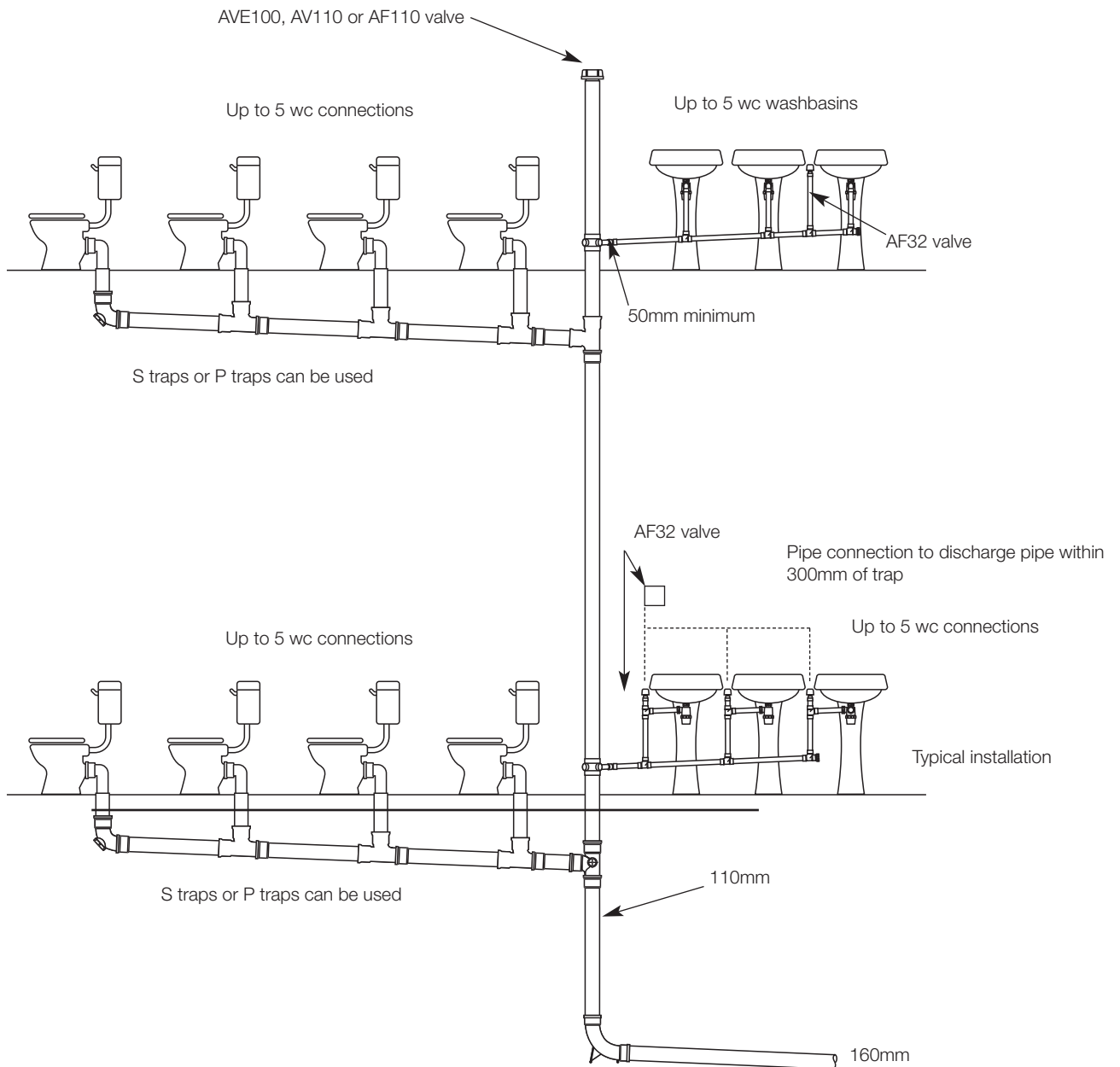


NOTES:

- Access arrangements shown are indicative only and may be varied to suit particular system layouts.
- The underground drain must be designed in accordance with BS EN 752-1: 1996, BS EN 752-2: 1997, BS EN 752-3: 1997, BS EN 752-4: 1998.
- If the branch drain is fitted with an intercepting trap before the connection of the main drain/sewer then a conventional open-topped ventilation discharge stack must be provided at the nearest point upstream of the intercepting trap.



Figure 5 Typical Non-Domestic (eg offices, factories, schools and other types of public buildings)



(1) The valve can be positioned below the flood level (i.e. a level of which an appliance would overflow) in accordance with Table 1 of this document.

NOTES:

- Valves to be fitted vertically.
- If the valve is fitted inside a duct then the duct will require ventilation.
- If access is required to the discharge stack then the valve must be fitted to a ring seal socket.
- Branch discharge pipes to ranges of appliances must be designed in accordance with clause 7.2.3 of BS 12056-2: 2000 where required branch pipe ventilation may be provided by a AF32 (50mm) valve.



11. Technical Investigations

The following is a summary of the technical investigations carried out on FloPlast Air Admittance Valves.

11.1 As a part of the assessments undertaken in the issue of Kitemark certificate KM512474 tests were carried out in accordance with BS EN 12380: 2002 to determine:

- Impact drop test and correct functioning in accordance with clause 6.2 of BS EN 12380.
- Airtightness under normal operating conditions in accordance with clause 6.3 of BS EN 12380.
- Endurance and temperature cycling at -20°C and +60°C followed by airtightness in accordance with clause 6.4 of BS EN 12380.
- Opening characteristics and airflow capacity testing in accordance with clause 6.5 of BS EN 12380.
- Tested for effectiveness at temperatures below zero to -20°C in accordance with clause 6.5 of BS EN 12380.

11.2 Tests were conducted to determine the performance in use for the conditions covered in the Design Data of this document.

11.3 The manufacturing process applied to these products are controlled with FloPlast BS EN ISO 9001: 2000 Quality Management System (Certificate No. FM501414). These processes are regularly audited by representatives of BSI to ensure continued compliance with our detailed processes.

Bibliography

BS 4514: 2001 Unplasticized PVC soil and ventilating pipes of 82.4 mm minimum mean, outside diameter and fittings and accessories of 82.4 mm and of other sizes — specification.

BS 5255: 1989 Specification for thermoplastics waste pipe and fittings.

BS 5572: 1994 Code of practice for sanitary pipework.

BS EN 752-1: 1996 Drain and sewer systems outside buildings — Generalities and definitions.

BS EN 752-2: 1997 Drain and sewer systems outside buildings — Performance requirements.

BS EN 752-3: 1997 Drain and sewer systems outside buildings — Planning.

BS EN 752-4: 1998 Drain and sewer systems outside buildings — Hydraulic design and environmental considerations.

BS EN 1329-1: 2000 Plastics piping systems for soil and waste discharge (low and high temperature) within the building structure — Unplasticized Poly(vinyl chloride) (PVC-U).

BS EN 1451-1: 2000 Plastics piping systems for soil and waste discharge (low and high temperature) within the building structure — Polypropylene (PP) — Specifications for pipes, fittings and the system.

BS EN 12056-1: 2000 Gravity Drainage Systems inside buildings — General and performance requirements.

BS EN 12056-2: 2000 Gravity Drainage Systems inside buildings — Sanitary pipework, layout and calculation.

BS EN 12380: 2002 Air Admittance Valves for drainage systems — Requirements, test methods and evaluation of conformity.

PVC-UE Roofline,
Window &
Cladding Systems

Rainwater
Systems

Soil & Waste
Systems

Underground
Drainage
Systems

MDPE
Systems

Hot & Cold
Plumbing
Systems



12. Conditions

12.1 This document:

- (a) Relates only to the product that is named, described, installed, used and maintained as set out in this document;
- (b) Is granted only to the company, firm or person identified on the front cover — no other company, firm or person may hold or claim any entitlement to this document;
- (c) Is valid only within the UK;
- (d) Has to be read, considered and used as a whole document — it may be misleading and will be incomplete to be selective;
- (e) Is subject to English law.

12.2 References in this certificate to any Act of Parliament, Regulation made there under, Directive or Regulation of the European Union, Statutory Instrument, Code of Practice, British Standard, manufacturers' instructions or similar publication, are references to such publication in the form in which it was current at the date of this document.

12.3 This certificate will remain valid for an unlimited period provided that the product and the manufacture and/or fabrication including all related and relevant processes thereof:


- (a) Are maintained at or above the levels which have been assessed and found to be satisfactory by the BSI;
- (b) Continue to be checked as and when deemed appropriate by the BSI under arrangements that it will determine;
- (c) Are reviewed by the BSI as and when it considers appropriate.

12.4 In issuing this document, FloPlast is not responsible for:

- (a) the right of the document holder to market, supply, install or maintain the product;
- (b) the actual works in which the product is installed, used and maintained, including the nature, design, methods and workmanship of such works.

12.5 Any recommendations relating to the use or installation of this product, which are contained or referred to in this document are the minimum standards required to be met when the product is used. They do not support in any way to restate the requirements of the Health & Safety at Work Act 1974, or of any other statutory, common law or other duty which may exist at the date of this document or in the future; nor is conformity with such recommendations to be taken as satisfying the requirements of the 1974 Act or of any present or future statutory, common law or other duty of care.

In granting this document, FloPlast does not accept responsibility to any person or body for any loss or damage, including personal injury, arising as a direct or indirect result of the installation and use of this product.

In demonstrating their compliance with BS EN 12380: 2002 FloPlast's Air Admittance Valves are fit for their intended use provided they are installed, used and maintained as set out in this document, the BSI Kitemark Certificate Kitemark 512474  has been awarded to FloPlast.

PVC-UE Roofline,
Window &
Cladding Systems

Rainwater
Systems

Soil & Waste
Systems

Underground
Drainage
Systems

MDPE
Systems

Hot & Cold
Plumbing
Systems