



Part No. DOC30 REV04 October 2008

## SUPPLEMENTARY INSTALLATION INSTRUCTIONS

# Vertical Balanced Flue Kit All Internal Grant Boilers

**THIS SUPPLEMENT SHOULD BE READ IN  
CONJUNCTION WITH THE INSTALLATION MANUAL  
SUPPLIED WITH THE BOILER**

### GENERAL

#### Flue sections cannot be cut.

Outer diameter of flue pipe: VTK05 - 150mm, VTK06 - 180mm.

**Adjustable sections.** The adjustable extensions are telescopic. **Always adjust to the required length using a twisting motion.** The outer pipes must overlap by a minimum of 35mm.

The Vertical Balanced flue kit is supplied in 5 sections. For the purpose of clarity in these instructions the sections have been designated (A),(B),(C),(D),(E) and (F).

The flue pipe seals are factory fitted and must be lubricated with the lubricant supplied.

The standard flue kit adjusts between approximately 2.4 and 3 metres from the top of the boiler water jacket to the top of the terminal.

The height of the kit may be increased (up to a maximum height of 12 metres) using extensions . Four extensions are available from Grant UK (see Figure 1 below).

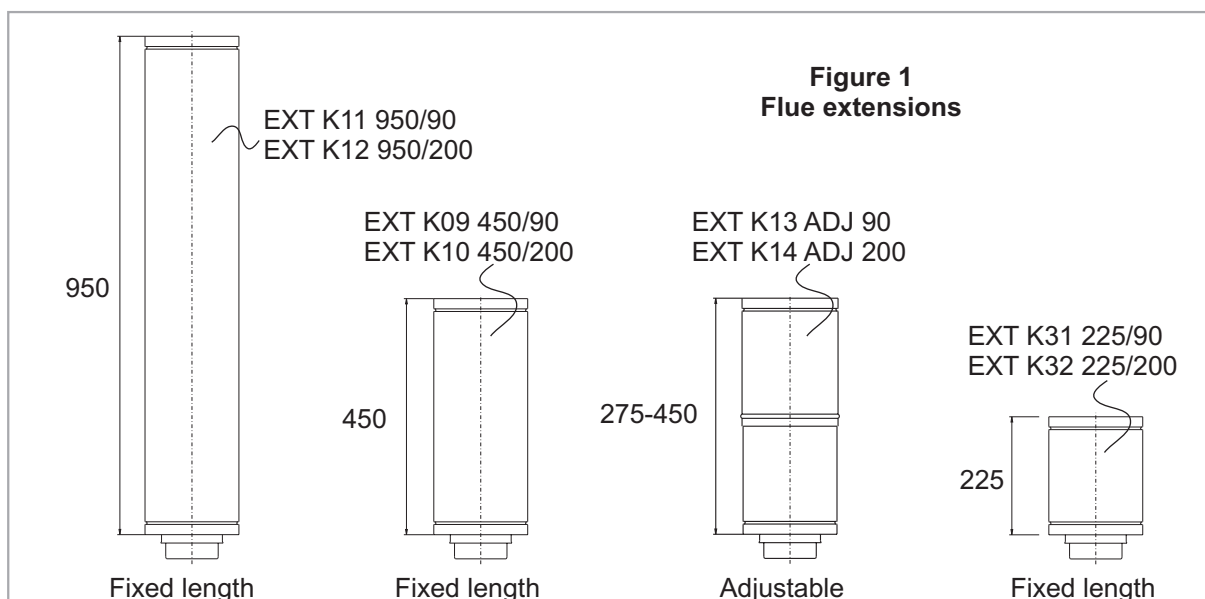

# FITTING INSTRUCTIONS

The dimensions shown are measured from the top of the boiler flue outlet, on cased models. The distance between the boiler flue outlet and the top of the casing should be taken into consideration.

Section (B) is the starter piece for the system and push fits into the boiler connector (A) supplied with the kit. Section (B) incorporates the air supply spigot and a combustion test point.

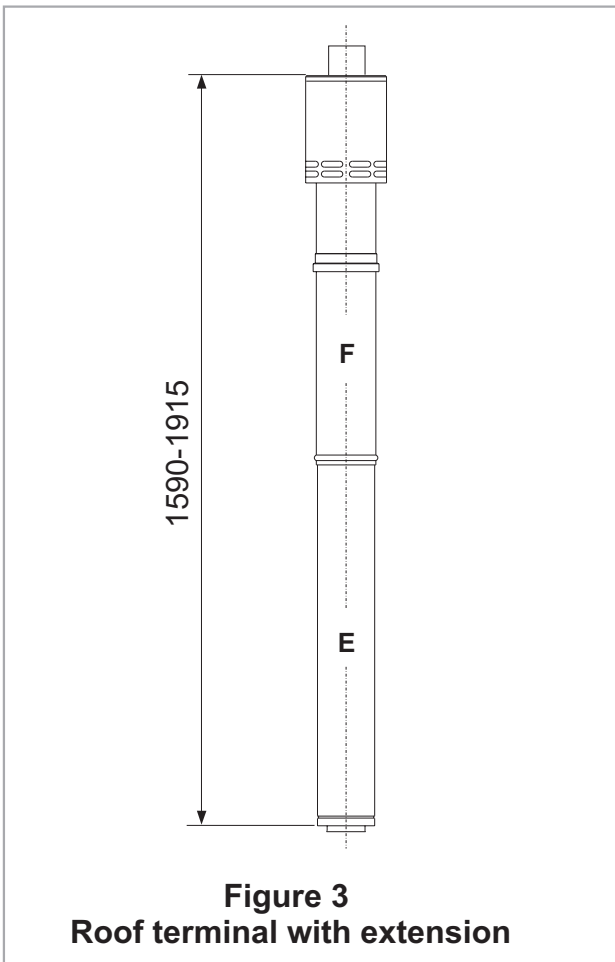

Sections (C) and (D) combine to form a telescopic length. Terminal section (F) slides telescopically over fixed length section (E).

For short flue heights (E) may be omitted and the terminal section (F) may be fitted directly to section (D) (see figure 4) The terminal section (F) overlaps section (D) by 50mm. Telescopic adjustment if required of the flue is still possible between sections (C and D).

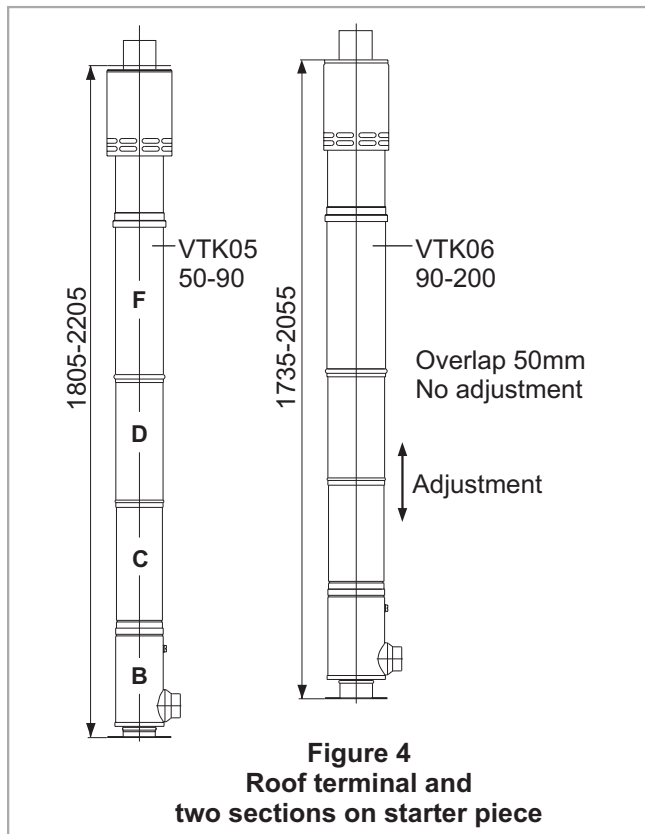
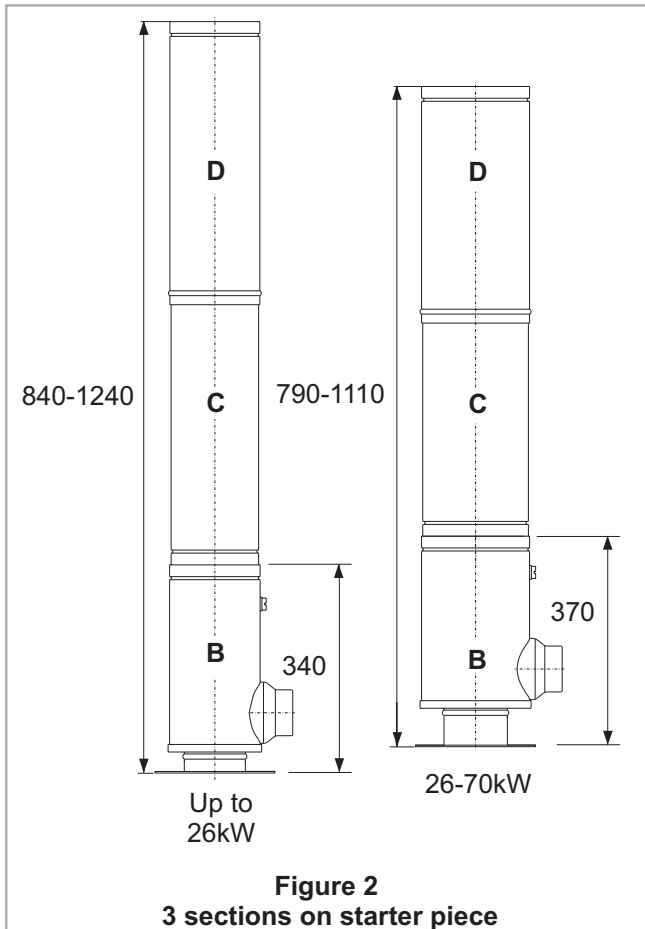

# FITTING INSTRUCTIONS

Three types of locking band are supplied with the kit. One for sections that butt together, one for adjustable sections and one for the terminal section. The locking bands for the adjustable and terminal sections are labelled for easy identification.

The flue system may be offset using 45° elbows. Each elbow has an equivalent height of 1 metre which must be deducted from the maximum height of 12 metres. Only six elbows should be used per kit. The elbows may be connected together or used individually to connect to extra extensions to form offsets as shown below.

The vertical flue kits incorporate a coated terminal section with integral storm collar factory fitted. The terminal is designed to locate into The Grant pitched or flat roof flashing leaving a fixed length of approximately 600mm above the roof line.

**The type of flashing required must be specified at time of order and is not included with the flue kit.**

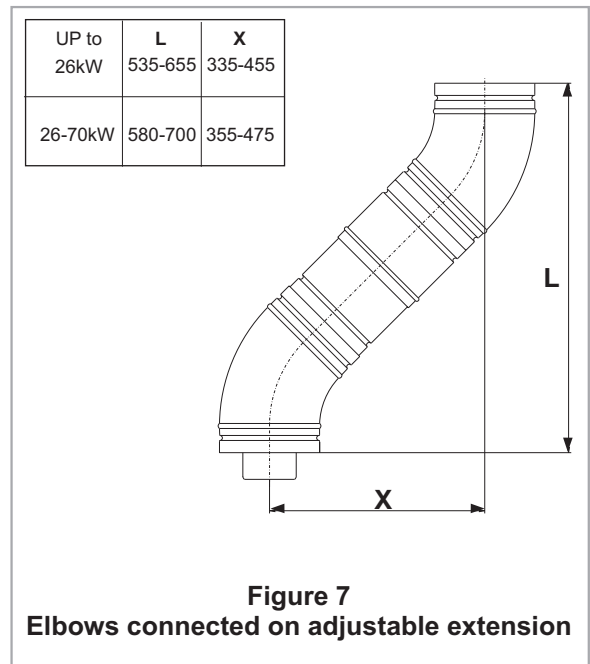
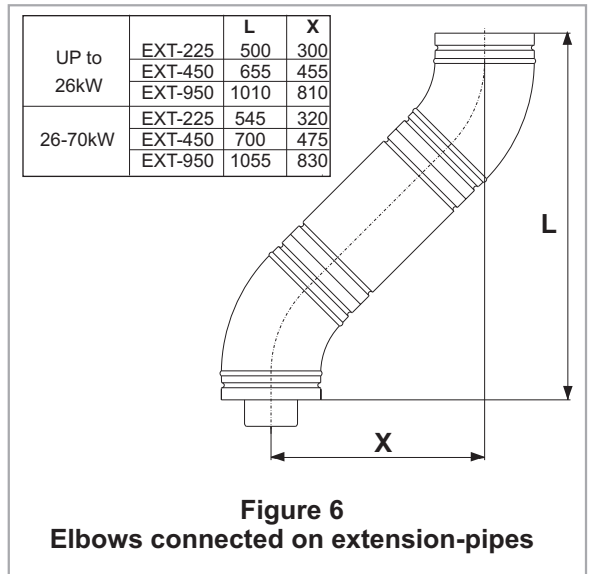
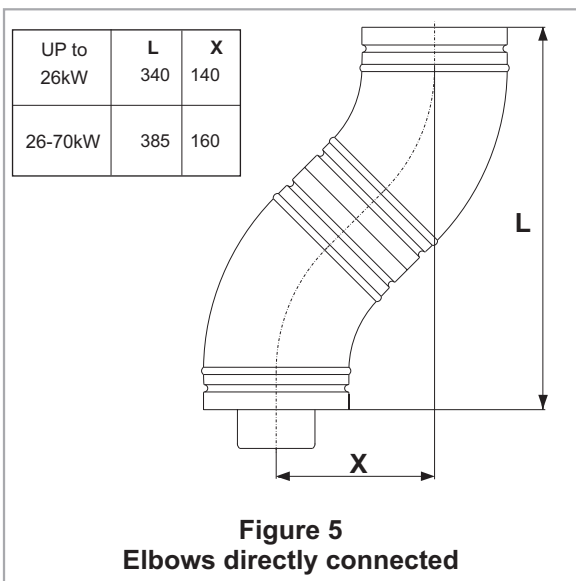

# FITTING INSTRUCTIONS

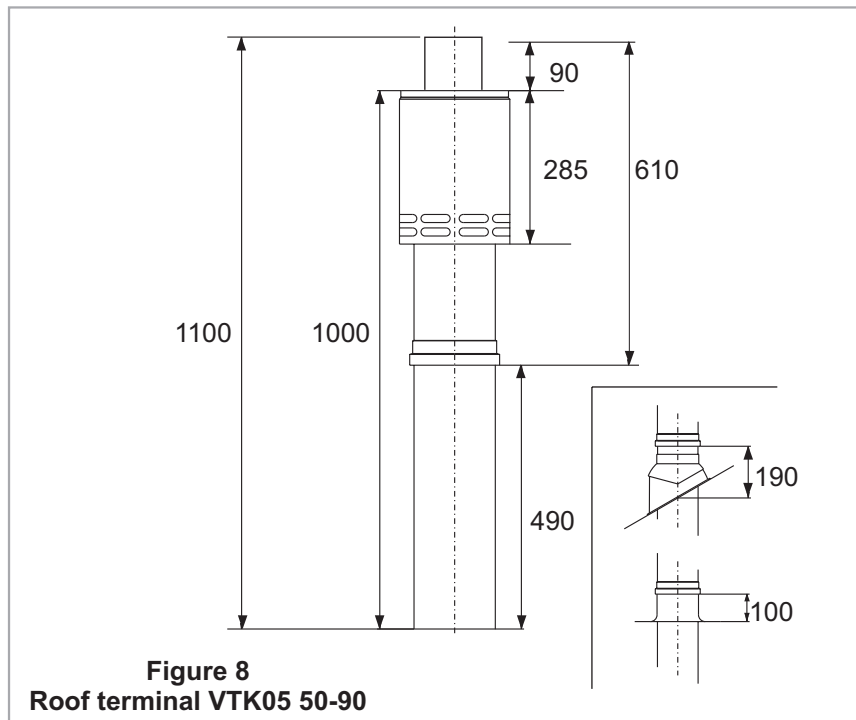

**Note:** The position of the storm collar. The storm collar locates into the top of the Grant pitched and flat flashing.

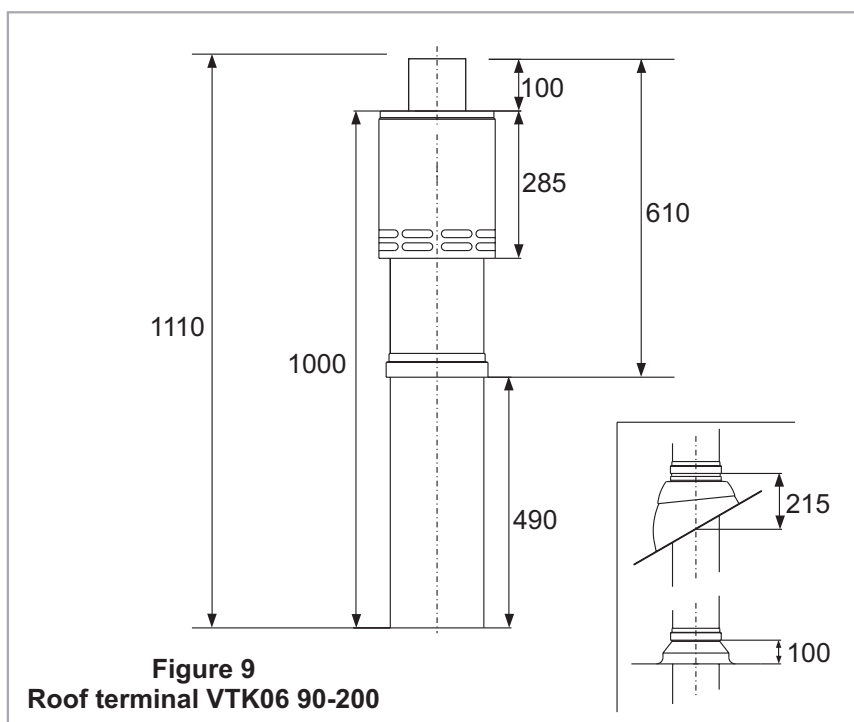

## FITTING INSTRUCTIONS

### TO FIT A VERTICAL BALANCED FLUE

Unpack the flue kit

Decide upon the position of the boiler and determine exactly where the flue will pass through the ceiling and roof. Check that there are no roof members or obstructions in the way of the intended flue route.

VTK05 50/90, cut clearance holes of 175mm diameter through the ceiling and roof.

VTK 06 90/200, cut clearance holes of 200mm diameter through the ceiling and roof.

Unpack the accessory pack.

Remove the boiler top panel or panels, depending on the model being installed.

**Grant Vortex Condensing Models only:** Clamp the boiler connector (A) to the neoprene gasket fitted to the boiler flue outlet using the stainless steel bolt supplied with the boiler.

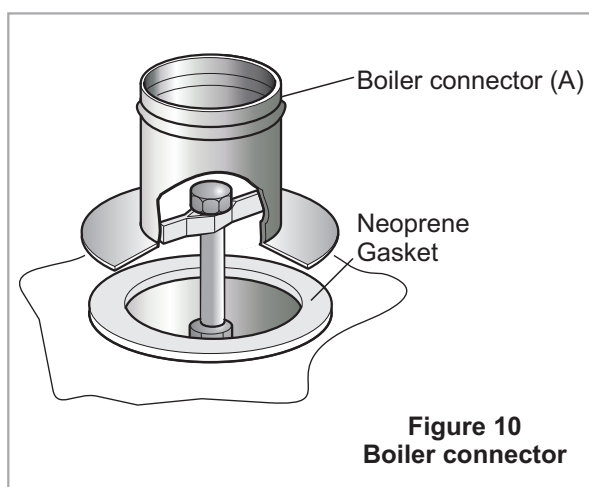

Locate the boiler connector (A) centrally into the gasket on the top of the boiler. Tighten the bolt to fix the connector in place (see figure 10).

Ensure the factory fitted red seal is in position in the swage in the boiler connector (see figure 11).

Take the starter section (B) of vertical flue pipe and check the seal is fitted as shown (see figure 12).

Apply lubricant to lip of the red seal in the boiler connector.

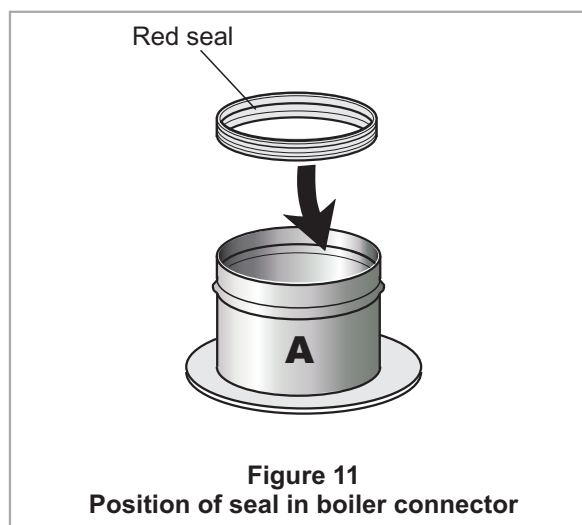

Push fit starter section (B) of flue pipe into the boiler connector. Ensure that the test point screw is orientated for easy access for flue gas analysis and combustion testing.

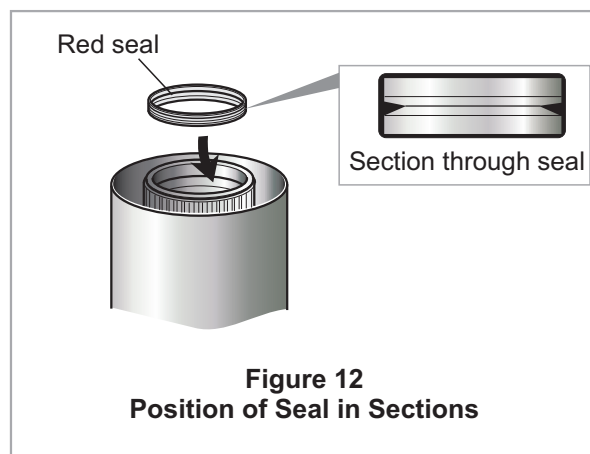

Connect the flexible air tube to the air inlet spigot on section (B) and secure with the hose clamp supplied (see figure 13).

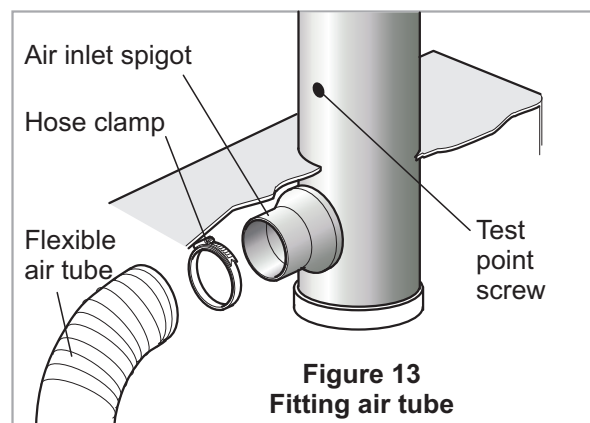

## FITTING INSTRUCTIONS

Remove the test point screw.

Fit top panel over the flue pipe and fit to the boiler casing. Take an outer flue locking band for the fixed sections and place over the top of the first section of flue ready to clamp the next section of flue.

Ensure the red seal is fitted into the swage in the inner pipe of the starter section (B). Lubricate the seal. Take the lower section of the vertical flue pipe (C) and push fit into starter section (B) using a twisting motion.

Fit a fixed section locking band to join the outer pipes.

Ensure the red seal is fitted into the swage in the inner pipe of the lower section (C). Lubricate the seal. Take the upper section (D) of the vertical flue pipe and push fit into lower section (C), using a twisting motion, ensuring the outer pipes overlap by a minimum of 35mm.

**After locating the upper section of an adjustable flue section and after assembly of the complete system ensure that the adjustable section is fixed using the screws provided. This applies to the bottom section of the roof terminal and any telescopic extension. Place the special locking band for adjustable sections over the outer pipe joint (see figure 14).**

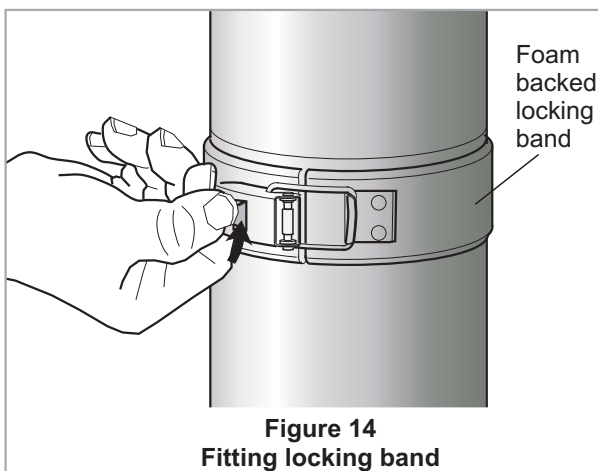

Take the fixed section (E) of flue pipe and check a red seal is in position in the swage. Lubricate the lip of the red seal in the top of section (D). Fit

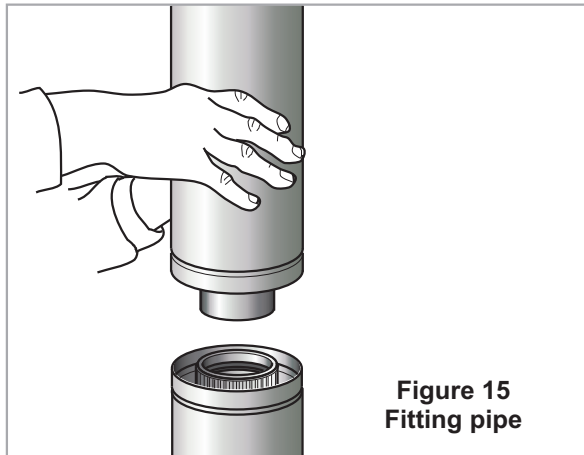

the section of flue pipe (E) in the top of section (D). The outer pipes butt together.

Fit a locking band with foam seal to the outer pipes ensuring that the band locates into the recess on the outer pipes (see figure 14). Ensure that an airtight seal is made between seals and locking bands as before.

A ceiling dress plate is supplied and may be fitted at this stage.

Push fit any additional extensions or remaining sections using the locking bands as before.

## FITTING INSTRUCTIONS

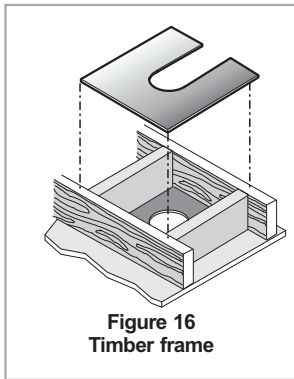

**Figure 16**  
Timber frame

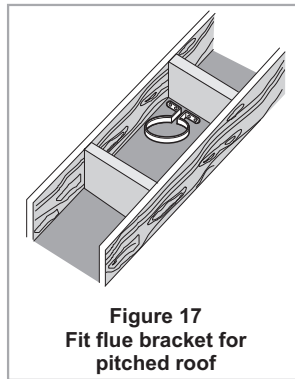

**Figure 17**  
Fit flue bracket for pitched roof

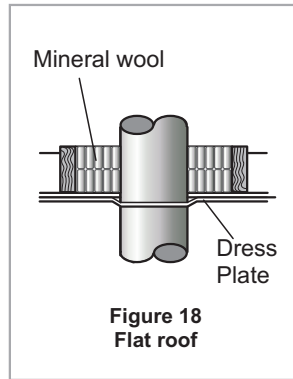

**Figure 18**  
Flat roof

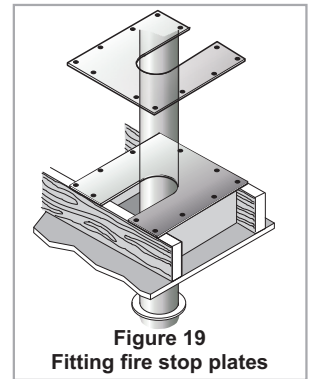

**Figure 19**  
Fitting fire stop plates

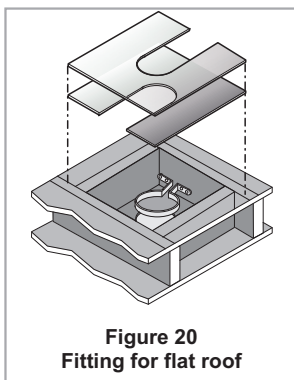

**Figure 20**  
Fitting for flat roof

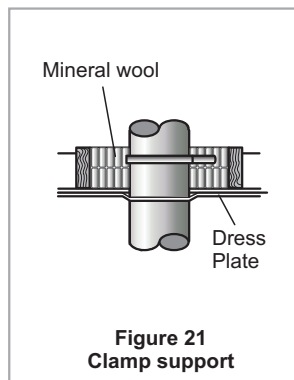

**Figure 21**  
Clamp support

If required fit the fire stop kit as shown in Figures 16 to 21. Construct a boxing as shown. Fill the void around the flue pipe with rockwool or glassfibre insulation.

Fit the flat or pitched roof flashing as required (see Figures 22 and 23) ensuring that a watertight seal is made between the flashing and the roof.

The sliding cap of the pitched flashing can be used in two positions depending on the pitch angle of the roof. Ensure that the sliding cap fully covers the spigot of the flashing to provide a watertight seal.

Fit the terminal section (F) ensuring that the integral storm collar locates correctly over the flashing. The terminal section slides telescopically over the section below it (except when fitted to section (D), fit the bracket ensuring that the weight of the terminal is carried by the clamp supplied and not by the flashing).

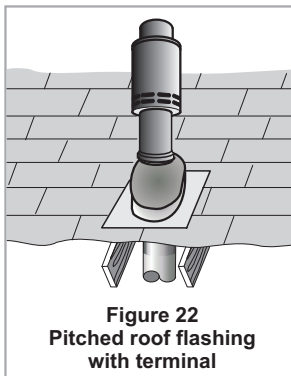

**Figure 22**  
Pitched roof flashing with terminal

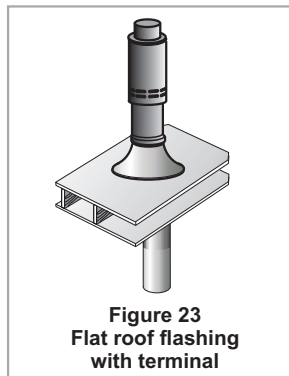

**Figure 23**  
Flat roof flashing with terminal



**Grant Engineering (UK) Limited**

Hopton House, Hopton Industrial Estate, Devizes, Wiltshire SN10 2EU

Telephone: (01380) 736920 Fax: (01380) 736991

email: [info@grantuk.com](mailto:info@grantuk.com) website: [www.grantuk.com](http://www.grantuk.com)

This manual is accurate at the date of printing but will be superseded and should be disregarded if specifications and/or appearances are changed in the interests of continued product improvement.

All goods sold are subject to our official Conditions of Sale, a copy of which may be obtained on application.

© Grant Engineering (UK) Limited 2008. No part of this manual may be reproduced by any means without prior written consent.