

# PRE-PIPING KIT

---

**LOGIC** System

**LOGIC +** System

When replacing any part on this appliance, use only spare parts that you can be assured conform to the safety and performance specification that we require. Do not use reconditioned or copy parts that have not been clearly authorised by Ideal.

**For the very latest copy of literature for specification and maintenance practices visit our website [www.idealheating.com](http://www.idealheating.com) where you can download the relevant information in PDF format.**

# PRE-PIPING KIT

This pre-piping kit is suitable for installation with the following boilers:

Logic System 15 ..... G.C. No. 41-750-24  
 Logic System 18 ..... G.C. No. 41-750-25  
 Logic System 24 ..... G.C. No. 41-750-26  
 Logic System 30 ..... G.C. No. 41-750-27

Logic + System 15 ..... G.C. No. 41-750-29  
 Logic + System 18 ..... G.C. No. 41-750-30  
 Logic + System 24 ..... G.C. No. 41-750-31  
 Logic + System 30 ..... G.C. No. 41-750-32

## 1 KIT CONTENTS

- A. Wall mounting template - 1 off
- B. Wall mounting bracket - 1 off
- C. Wall plate - 1 off
- D. Bracket bulkhead - 1 off

### Hardware Pack Contents :-

- E. Flow valve (gauge) pack - 1 off
- F. Gas valve pack - 1 off
- G. Return valve pack - 1 off
- H. Screw - 2 off (Please discard)
- J. Wall plug - 2 off (Please discard)

### Fixing Pack Contents :-

- K. M6 x 10 Pozi Pan screws - 4 off
- L. M6 Hex. Nut - 2 off
- M. Wall plug - 3 off
- N. Screw - 3 off

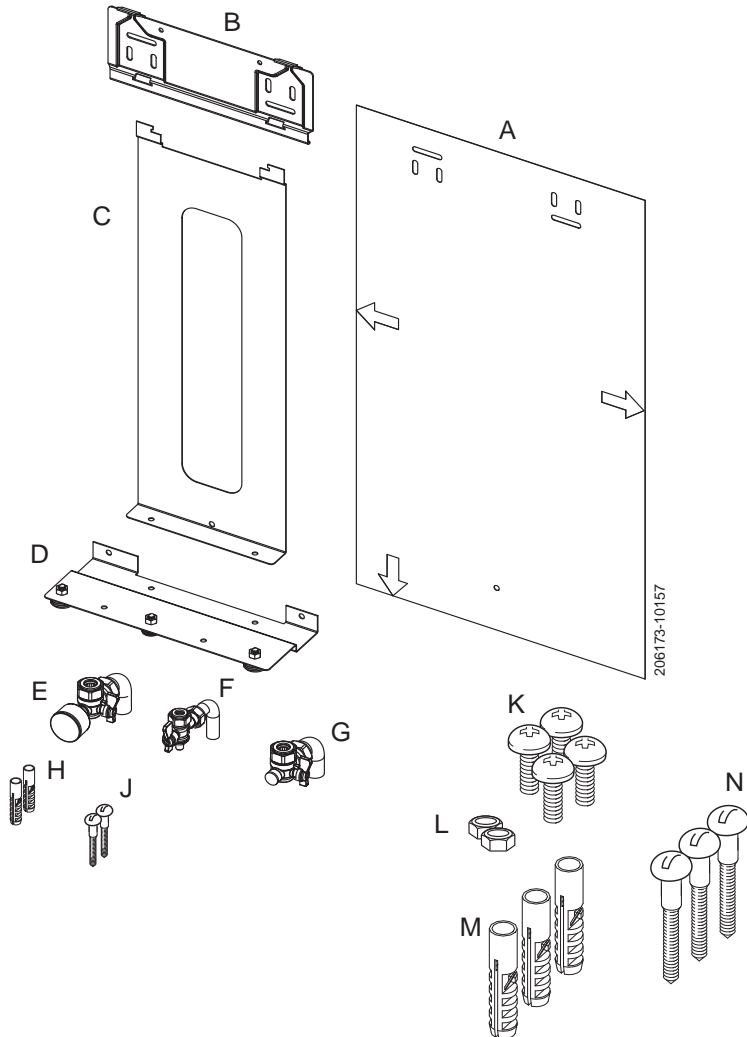

## 2 PREPARATION

Please note this kit has been designed to be used on its own or with separate stand off frame kit if required. This stand off kit facilitates upward routing of all the boiler pipework between the back of the above boilers and the wall if needed.

### 3 FITTING THE PRE-PIPING KIT

#### Directly to the wall :

1. Use the wall mounting template to determine the correct positioning of the boiler and pre-piping mounting bracket.
2. Drill two holes for fastening the wall mounting bracket and the third bottom central hole as instructed on the template.
3. Insert wall plugs provided.
4. Attach the wall plate to the wall mounting bracket by angling the wall plate into the slots in the wall mounting bracket. As shown below.
5. With the two items attached fix onto the wall via the three plugs and screw firmly to the wall.
6. Place the bracket bulkhead on top of the wall plate return and fasten together using the two M6 screws and nuts.
7. Position and secure the valves and pipes as shown to the bracket bulkhead using the fibre washers supplied.
8. The copper tail pipes can now be connected to the appropriate valve. When completed, pressure testing the circuit can be done. Ensure the valves are closed and the appropriate fibre washers have been fitted.

**Note:** -BLUE washer for gas valve.

#### Fitting the boiler:

1. Before fitting the boiler, slacken all the valve union nuts from the bracket bulkhead connectors.
2. Remove the two M6 screws and nuts fastening the bracket bulkhead to the wall plate.
3. Unscrew completely the valve union nuts and remove and discard the bracket bulkhead.

Refer to boiler installation instructions for completion of boiler installation.

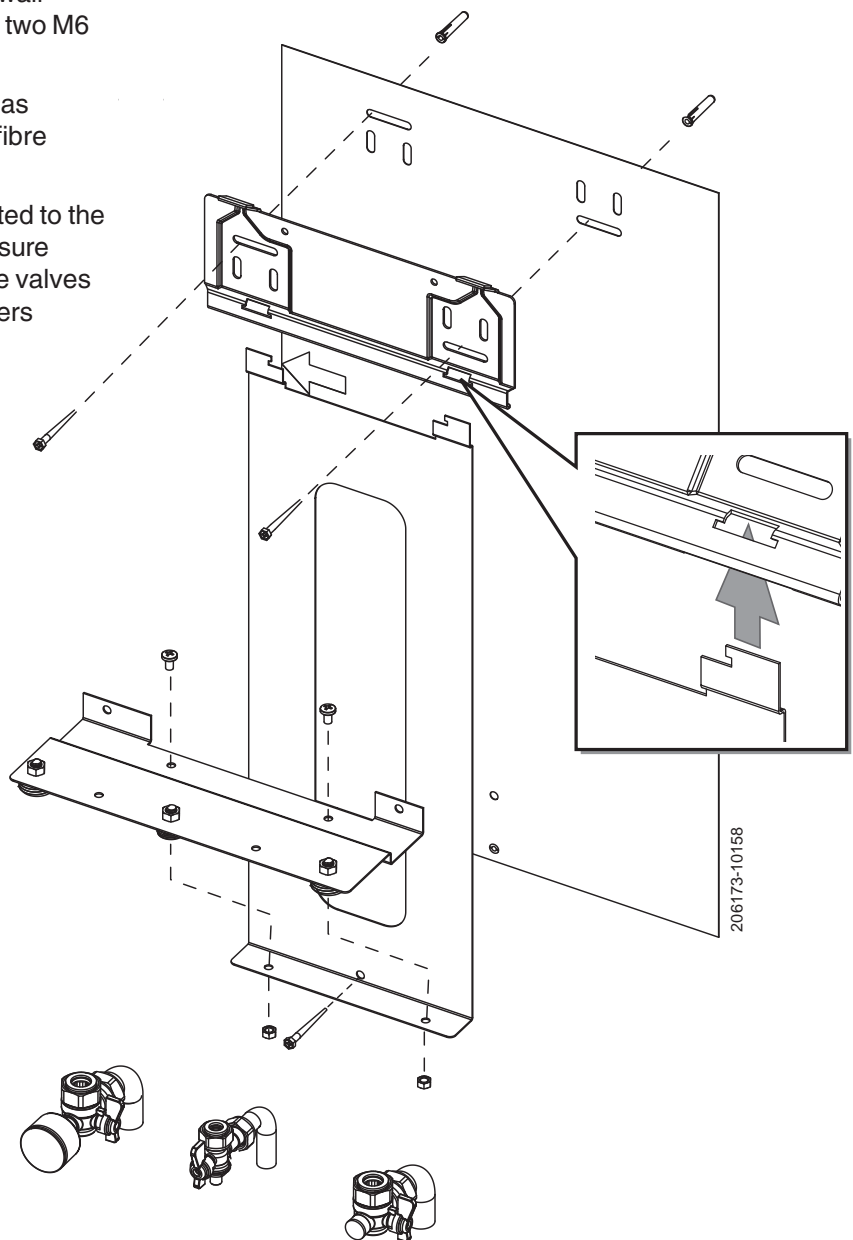

#### 4. UTILISING THE STAND-OFF KIT OPTION

1. Screw the stand-off frame to the wall using the screws provided.
2. Attach the wall mounting bracket to the stand-off frame using the 2 M6x10 screws provided in the stand-off kit.
3. Fix the bracket bulkhead to the stand-off frame using the 2 M6x10 screws provided.
4. Position and secure the valves and pipes as shown to the bracket bulkhead using the fibre washers provided.
5. Mount the boiler to the wall plate in accordance with the installation and servicing instructions.

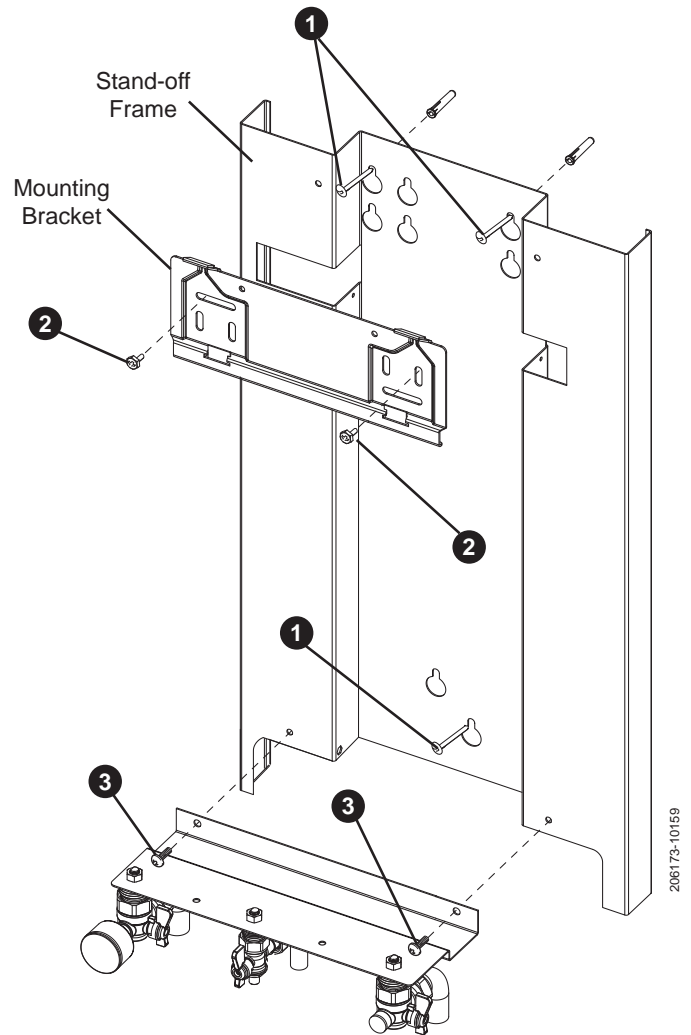

#### Technical Training

The Ideal Technical Training Centre offers a series of first class training courses for domestic, commercial and industrial heating installers, engineers and system specifiers. For details of courses please ring: ..01482 498 432

**Ideal Boilers**, P.O. Box 103, National Ave, Kingston upon Hull, HU5 4JN. Telephone: 01482 492 251 Fax: 01482 448 858. Registration No. London 322 137.

**Ideal Stelrad Group** pursues a policy of continuing improvement in the design and performance of its products. The right is therefore reserved to vary specification without notice.



Ideal Stelrad Group

***Ideal Installer/Technical Helpline: 01482 445570***

***www.idealheating.com***