

STAND-OFF KIT

LOGIC Heat

LOGIC + Heat

When replacing any part on this appliance, use only spare parts that you can be assured conform to the safety and performance specification that we require. Do not use reconditioned or copy parts that have not been clearly authorised by Ideal.

For the very latest copy of literature for specification and maintenance practices visit our website www.idealheating.com where you can download the relevant information in PDF format.

This kit is suitable for the following boilers:

Logic Heat 12 G.C. No. 41-399-99
 Logic Heat 15 G.C. No. 41-409-93
 Logic Heat 18 G.C. No. 41-409-94
 Logic Heat 24 G.C. No. 41-409-95
 Logic Heat 30 G.C. No. 41-409-96

Logic + Heat 12 G.C. No. 41-409-97
 Logic + Heat 15 G.C. No. 41-409-98
 Logic + Heat 18 G.C. No. 41-409-99
 Logic + Heat 24 G.C. No. 41-750-21
 Logic + Heat 30 G.C. No. 41-750-22

INTRODUCTION

The Stand-off Kit is a separately supplied pack to facilitate downward routing of the system flow and return pipework between the back of the boilers and the wall.

1 KIT CONTENTS

- A. Stand off Frame
- B. M6 x 10 PP Hd screws - 3 off
- C. Wall Plug - 3 off
- D. No. 10 x 50mm Wood Screw - 3 off
- E. Installation Instructions
- F. Wall Mounting Template

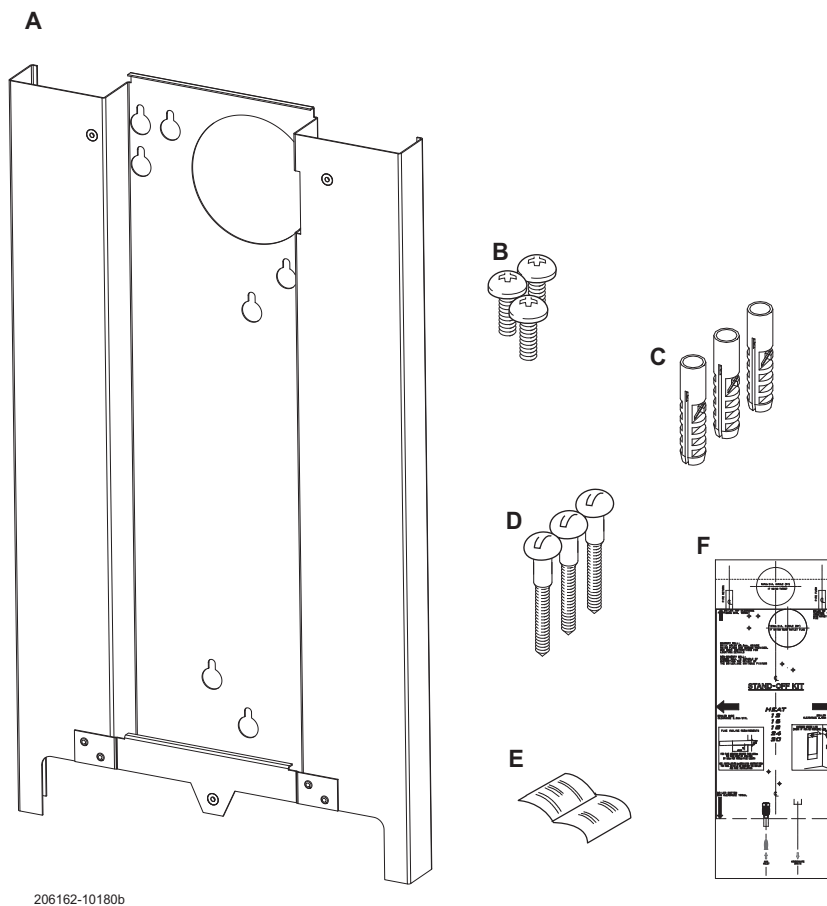

2 PREPARATION

Prepare the boiler for installation, according to the Installation & Servicing Instructions.

Note.

If the side flue installation is being used particular attention should be given to the Installation & Servicing Instructions and the wall mounting template to ensure the flue hole is correctly located.

3 INSTALLATION

IMPORTANT.

When piping within the stand-off channel use 22mm copper pipe and not 28mm.

1. Use the wall mounting template to determine the correct positioning of the boiler and stand-off frame.
2. Drill three holes for fastening the stand-off frame and drill the core hole for the flue as instructed on the template. *Note - the cored hole will not line up directly with the flue hole in the stand-off frame.*
3. Insert wall plugs provided and insert screws to a suitable depth, leaving adequate room to slot the frame over the head of the screw
4. Push the terminal assembly through the prepared hole in the wall until the rubber seal clears the outside wall. Rest the flue in the hole in the wall.
5. Offer the stand-off frame to the wall, slotting the hole over the flue (resting in the wall) and position the keyhole slots over the screws in the wall and tighten.
6. Secure the boiler wall mounting plate to the stand-off frame using the M6 screws provided.
7. Pull the flue assembly back through the wall mounting plate sealing the outside wall with the rubber wall seal and ensure the 3 locating tabs are pulled through the wall mounting plate slots.
8. Turn the plastic connector clockwise to lock the connector into the wall plate and secure with M6 screw provided .
9. Fabricate copper pipework to boiler service connections as follows. Pipework can be routed down. Care must be taken not to overheat any connecting ball valves or sealing washers.

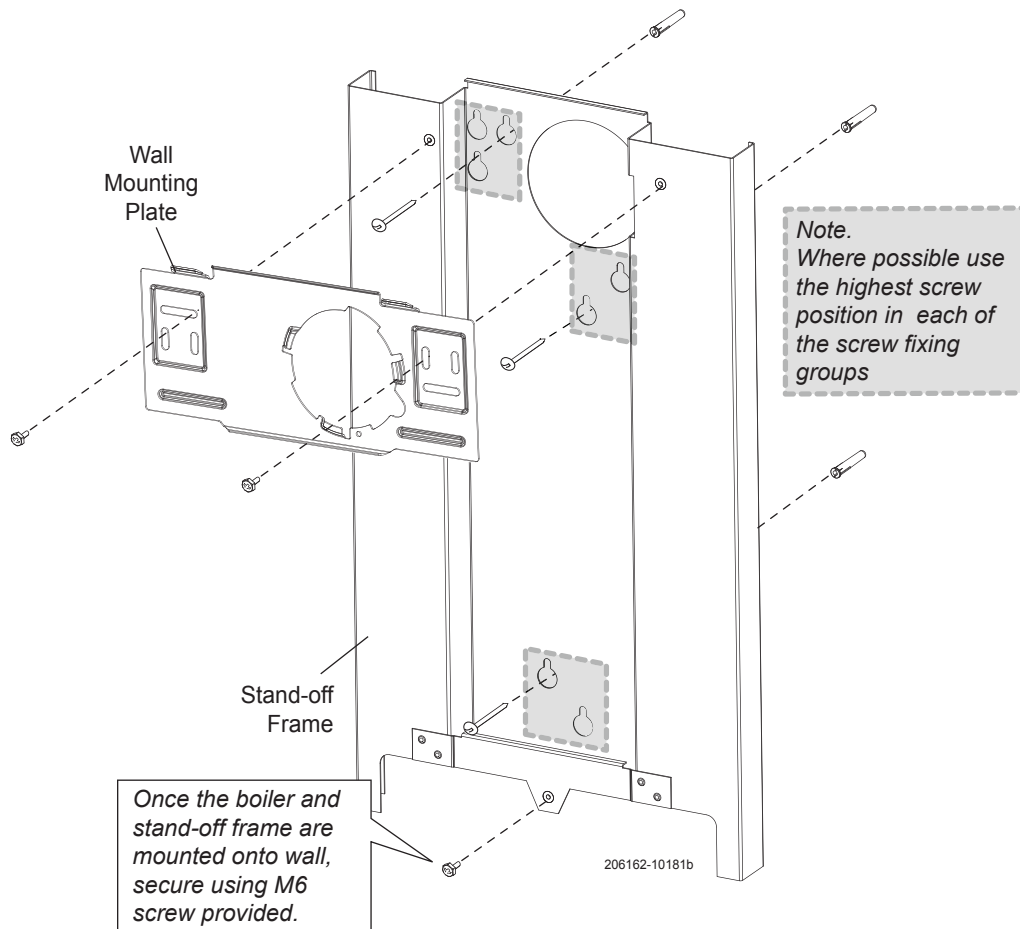

Boiler CH Flow & Return Connections - Connect installer-fabricated pipes directly to 22mm copper pipes on the top of the boiler.

Gas Connection - Connect installer-fabricated pipework directly to 15mm compression fitting incorporated on the gas connection isolation valve.

4 FINALLY

1. Go to Flue Outlet section in the Installation and Servicing manual.
2. Complete the installation and commissioning of the boiler, according to the Installation & Servicing manual.

Technical Training

The Ideal Technical Training Centre offers a series of first class training courses for domestic, commercial and industrial heating installers, engineers and system specifiers. For details of courses please ring: 01482 498 432

Ideal Boilers, P.O. Box 103, National Ave, Kingston upon Hull, HU5 4JN. Telephone: 01482 492 251 Fax: 01482 448 858. Registration No. London 322 137.

Ideal Stelrad Group pursues a policy of continuing improvement in the design and performance of its products. The right is therefore reserved to vary specification without notice.



Ideal Stelrad Group

Ideal Installer/Technical Helpline: 01482 445570
www.idealheating.com