



## Concept Cube 50cm Short Projection Semi-Countertop Washbasin, 1 RH Taphole

### Illustrated

- E7799** Concept Cube 50cm short projection semi countertop washbasin, glazed back edge, 1 right hand taphole with overflow
- B9915** Concept Blue washbasin mixer 1 hole with pop-up waste
- S8910** Trap 1 1/4" plastic bottle, 75mm seal, multi-purpose outlet

### Configuration options

#### Material

Fine Fireclay

#### Weights

E7799 12.73KG  
 B9915 1.89KG  
 S8910 0.20KG

#### Colours

White (01)

#### Standards

Washbasin to BS EN 14688 & BS EN 31

#### Special Notes

Washbasin fixed to countertop with securing clips provided. Joint sealed with waterproof sealant (not supplied). Basin designed to leave a 10mm gap at rear to tile down onto worktop. We only recommend the use of our 210mm units with this basin.

#### Designer

Robin Levien, RDI

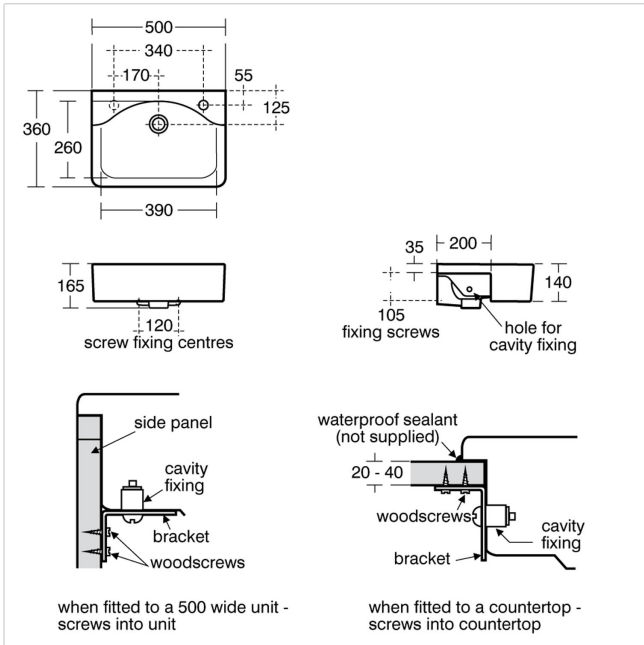

### Frequently used applications

- |                |                    |
|----------------|--------------------|
| Education      | General Healthcare |
| Hotels         | Office             |
| Pubs and Clubs | Residential        |
| Retail         | Sports and Leisure |

### Features

Space Saving



Email: [info@idealspec.co.uk](mailto:info@idealspec.co.uk)  
 Tel: 0870 122 8822  
 Fax: 0870 122 8282  
 Web: [www.idealspec.co.uk](http://www.idealspec.co.uk)

