

Concept Cube 50cm Short Proj S/C Washbasin, 1 LH Taphole

Illustrated

- E7798** Concept Cube 50cm short projection semi countertop washbasin, glazed back edge, 1 left hand taphole with overflow
- E0157** Wall fixing set
- B8062** Active single lever one hole basin mixer with pop-up waste.
- S8920** Trap 1¼" plastic resealing bottle, 75mm seal, multi-purpose outlet

Configuration options

Material

Fine Fireclay

Weights

E7798	12.73KG
E0157	0.16KG
B8062	2.42KG
S8920	2.00KG

Colours

White (01)

Standards

Washbasin to BS EN 14688 & BS EN 31

Special Notes

Washbasin fixed to countertop with securing clips provided. Joint sealed with waterproof sealant (not supplied). Basin designed to leave a 10mm gap at rear to tile down onto worktop. We only recommend the use of our 210mm units with this basin.

Designer

Robin Levien, RDI

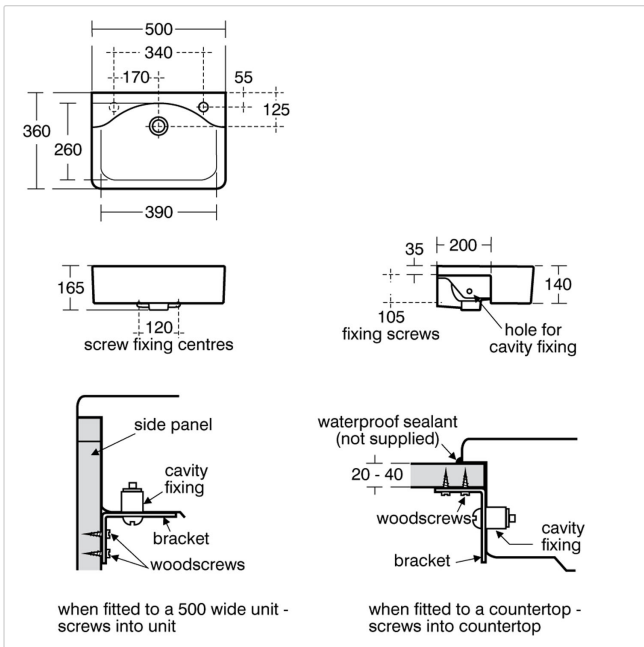

Frequently used applications

Education	General Healthcare
Hotels	Office
Pubs and Clubs	Residential
Retail	Sports and Leisure

Features

Space Saving



Email: info@idealspec.co.uk
 Tel: 0870 122 8822
 Fax: 0870 122 8282
 Web: www.idealspec.co.uk

