

INSTALLATION COMMISSIONING & SERVICING INSTRUCTIONS

GREENSTAR WIRING CENTRE

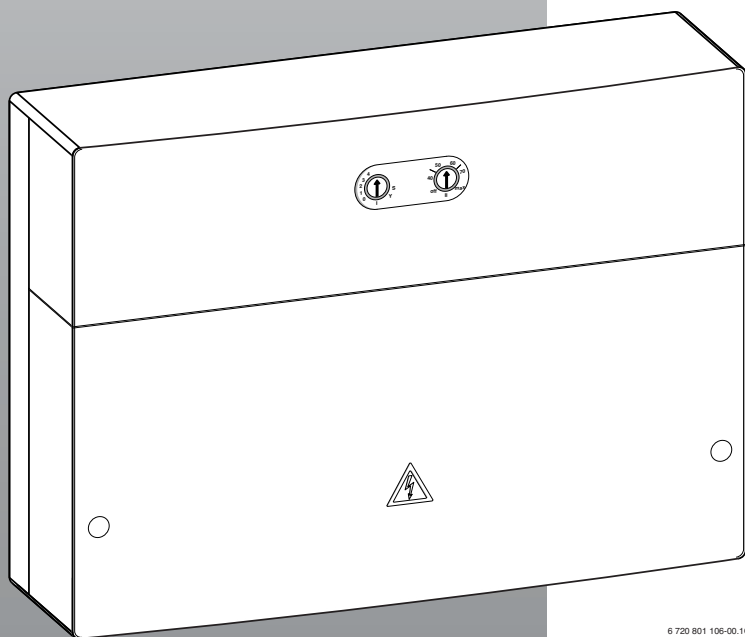

6 720 801 106-00.10



CONTENTS

1	Key to symbols and safety instructions	2
1.1	Key to symbols	2
1.2	Safety instructions	2
2	Product details	2
2.1	Correct use	3
2.2	Standard delivery	3
2.3	Specification	3
2.4	Cleaning and care	4
2.5	Additional system components	4
3	Installation	4
3.1	Installation	4
3.2	Electrical connections	5
3.2.1	Connection of BUS and temperature sensor ($\leq 24\text{ V}$) ..	5
3.2.2	Connection to mains power, pump and valves (230 V AC)	5
3.2.3	Wiring diagrams with system examples	8
4	Commissioning	13
5	Troubleshooting	13
5.1	Status indicator	13
5.2	Replacing the fuse	13
6	Environment / disposal	14

1 KEY TO SYMBOLS AND SAFETY INSTRUCTIONS

1.1 KEY TO SYMBOLS

WARNINGS



Warnings in this document are identified by a warning triangle printed against a grey background. Keywords at the start of a warning indicate the type and seriousness of the ensuing risk if measures to prevent the risk are not taken.

The following keywords are defined and can be used in this document:

- **NOTE** indicates a situation that could result in damage to property or equipment.
- **CAUTION** indicates a situation that could result in minor to medium injury.
- **WARNING** indicates a situation that could result in severe injury or death.
- **DANGER** indicates a situation that will result in severe injury or death.

IMPORTANT INFORMATION



This symbol indicates important information where there is no risk to people or property.

ADDITIONAL SYMBOLS

Symbol	Explanation
▶	Step in an action sequence
→	Cross-reference to another part of the document
•	List entry
–	List entry (second level)

Table 1

1.2 SAFETY INSTRUCTIONS

- ▶ Observe all country-specific regulations and standards during installation and operation.
- ▶ Observe all instructions to ensure satisfactory operation.
- ▶ This product must only be installed and commissioned by a competent person.
- ▶ Never install this product in wet rooms.
- ▶ Install and commission the boiler and other accessories according to the relevant instructions.
- ▶ Risk of scalding! A mixer device must be installed if water temperatures higher than 60 °C are set.
- ▶ Use this product exclusively in conjunction with the Worcester controls accessory and boilers that comply with the intended use. Follow the wiring diagram.
- ▶ The product requires different voltages. Do not connect the low-voltage equipment to 230 V mains and vice-versa.
- ▶ Before installing the product: electrically isolate the boiler and system components. Secure against unintentional reconnection and make sure the power supply is disconnected.

ABOUT THESE INSTRUCTIONS

These installation instructions contain important information regarding the safe and proper installation, commissioning and maintenance of the product.

These installation instructions are intended for competent persons who, as a result of their training and experience, are skilled in dealing with electrical installations and heating systems.

In these instructions the Greenstar Wiring Center will be referred as "module".

2 PRODUCT DETAILS



NOTICE: Floor damage!

- ▶ Underfloor heating installations must include a suitable controls package to prevent excessive flow temperatures entering the floor.

- The module controls the pump and motorized valves in
 - a mid-position (Y-plan) system
 - or–
 - a two-port valve (S-plan) system
 - or–
 - three central heating circuits only, without electronic mixing valves
 - or–
 - two central heating circuits without electronic mixing valves and one domestic hot water cylinder circuit.
- The module collects
 - the temperature of the DHW cylinder via the cylinder temperature sensor supplied
 - the demand signals (from room and/or frost thermostats optionally).

- Pump seizure protection function:
 - The connected pump is monitored and ran for a short period after 24 hours of downtime. This prevents the pump from seizing.

A maximum of three modules per system are permissible, irrespective of the number of other BUS subscribers:

- a maximum of two modules for a total of six heating circuits without electronic mixing valves
- a maximum of one module for two additional heating circuits without electronic mixing valves and one cylinder charging circuit

As delivered, the code switch is set to **Y**. The module will therefore operate the system as a mid-position (Y-plan). S (S-plan) or other configurations can be selected when necessary.

2.1 CORRECT USE

The module communicates via an EMS-plus interface with other EMS-plus-enabled BUS subscribers such as Greenstar boilers.

- ▶ Only use the appliance for its intended purpose.
- ▶ Observe all country-specific regulations and standards during installation and operation.

2.2 STANDARD DELIVERY

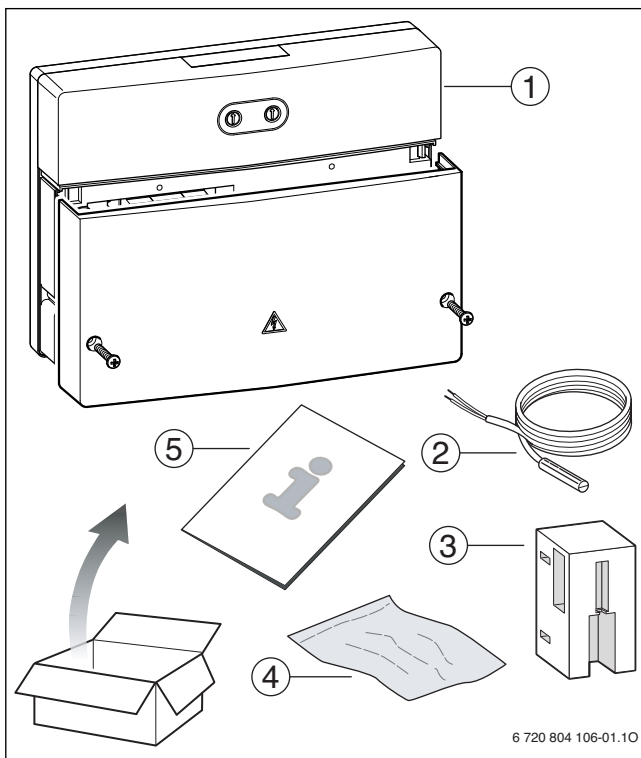

Fig. 1 Scope of supply

- [1] Module
- [2] Cylinder temperature sensor (TC1)
- [3] Cylinder temperature sensor (TC1) retaining device. To enable satisfactory installation of the cylinder temperature sensor on hot water cylinders without sensor pockets.
- [4] Bag with installation material
- [5] Installation instructions

2.3 SPECIFICATION

CE Design and operation of this product conform to European Directives and the supplementary national requirements. Its conformity is demonstrated by the CE designation.

Technical data	
Dimensions (W × H × D)	151 × 184 × 61 mm (further dimensions → fig. 2)
Maximum conductor cross-section	<ul style="list-style-type: none"> • Terminal 230 V • 2.5 mm² • Extra-low voltage connecting terminal • 1.5 mm²
Rated voltages	<ul style="list-style-type: none"> • BUS • 15 V DC (reverse-polarity-protected) • Module power supply • 230 V AC, 50 Hz • Pump and mixer • 230 V AC, 50 Hz
Fuse	230 V, 5 AT
BUS interface	EMS plus
Power consumption – Standby	< 1 W
max. power output	<ul style="list-style-type: none"> • per connection (PZ1 ... PZ3) • 400 W (high-efficiency pumps permissible; max. 40 A/μs) • per connection (IZ1 ... IZ4) • 230 V AC, max. 0.5 A
Temperature sensor measuring range	<ul style="list-style-type: none"> • lower fault limit • < -10 °C • display range • 0 ... 100 °C • upper fault limit • > 125 °C
Permissible ambient temperature	0 ... 60 °C
IP rating	IP 44
Id. no.	Type plate (→ fig. 3, page 4)

Table 2 Technical data

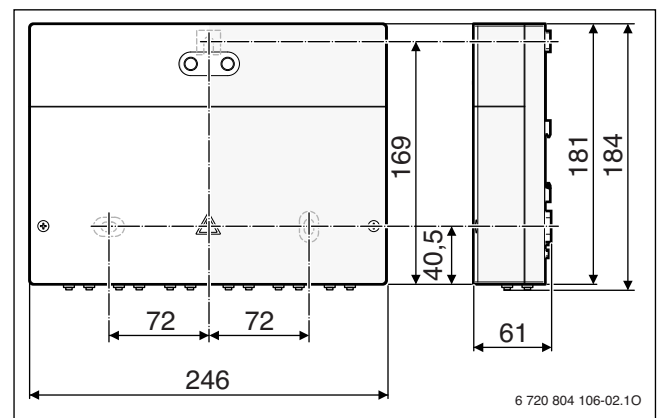

Fig. 2 Dimensions

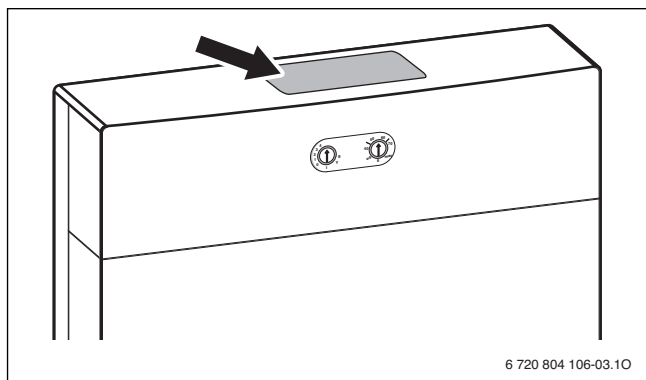

Fig. 3 Position of type plate

Test values for the cylinder temperature sensor (included with the product)

°C	Ω	°C	Ω
20	14772	56	3723
26	11500	62	3032
32	9043	68	2488
38	7174	74	2053
44	5730	80	1704
50	4608	86	1421

Table 3 Resistance vales of supplied cylinder temperature sensor.

2.4 CLEANING AND CARE

- ▶ If required, wipe the enclosure with a damp cloth. Never use chemically aggressive or acidic cleaning agents.

2.5 ADDITIONAL SYSTEM COMPONENTS

- For a mid-position (Y-plan) system:
 - Circulating pump; connection to PZ3
 - Mid-position valve; connection to PZ1 and PZ2
 - Room and/or frost thermostats (optional); connection to IZ3 and IZ4
- For a two-port valve (S-plan) system:
 - Circulating pump; connection to PZ3
 - 2 x 2-port valves (with end switches); connection to PZ1 and IZ1 and to PZ2 and IZ2
 - Room and/or frost thermostat (optional); connection to IZ3 and IZ4
- For heating circuits with separate heating pumps without electronic mixing valves (e.g. downstream of low-loss header):
 - Circulating pump; connection to PZ1...3
 - Room thermostat (optional); connection to IZ1...3
- For domestic hot water cylinder charging circuit with separate cylinder primary pump (e.g. downstream of low-loss header):
 - Cylinder primary pump; connection to PZ1
 - Cylinder temperature sensor; connection to TC1

INSTALLATION OF ADDITIONAL SYSTEM COMPONENTS

- ▶ Fit additional system components according to legal requirements and the installation instructions provided.

3 INSTALLATION



DANGER: Risk of electric shock!

- ▶ Prior to the installation of this product: Isolate the boiler and system components from the power supply (230 V AC).
- ▶ Before commissioning: Fit the cover (→ Fig. 19, page 8).

3.1 INSTALLATION

WALL MOUNTING

- ▶ Mount the module to a wall (→ Fig. 4 to 6).

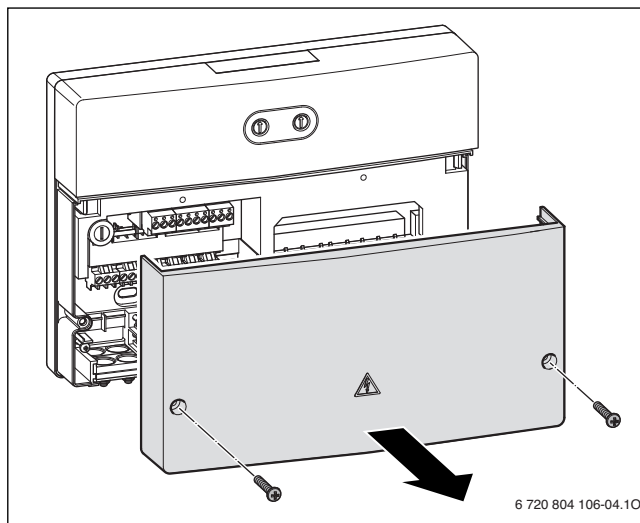

Fig. 4 Wall mounting - step 1

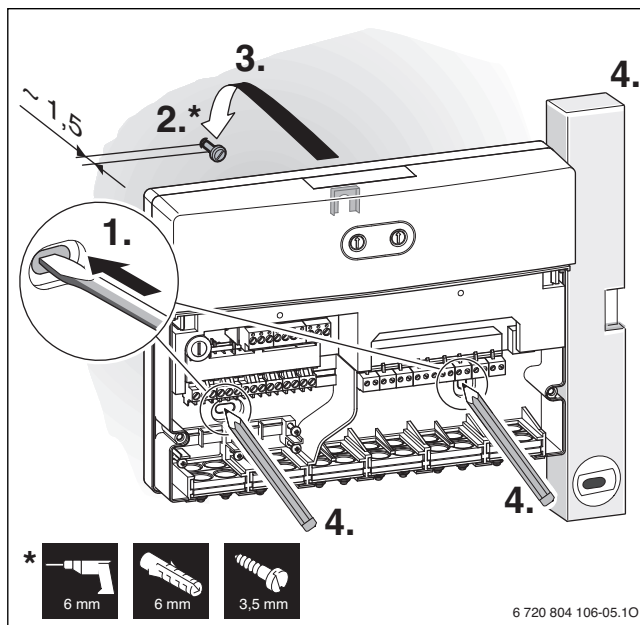

Fig. 5 Wall mounting - step 2

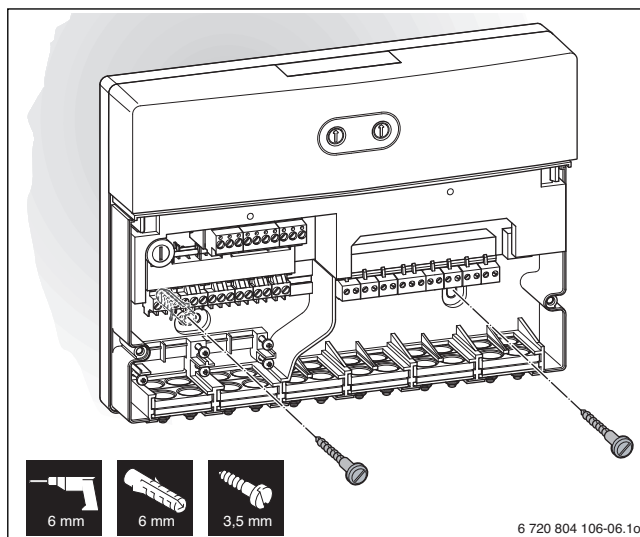

Fig. 6 Wall mounting - step 3

DIN RAIL MOUNTING

► Mount the module to a DIN rail (→ fig. 7).

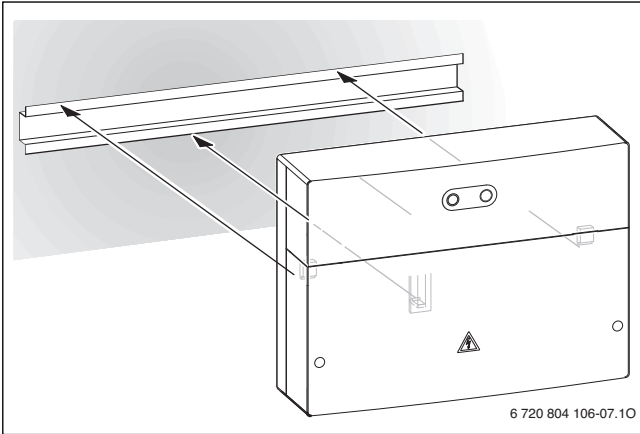

Fig. 7 DIN rail mounting

► Observe fig. 8 when removing the component from the DIN rail.

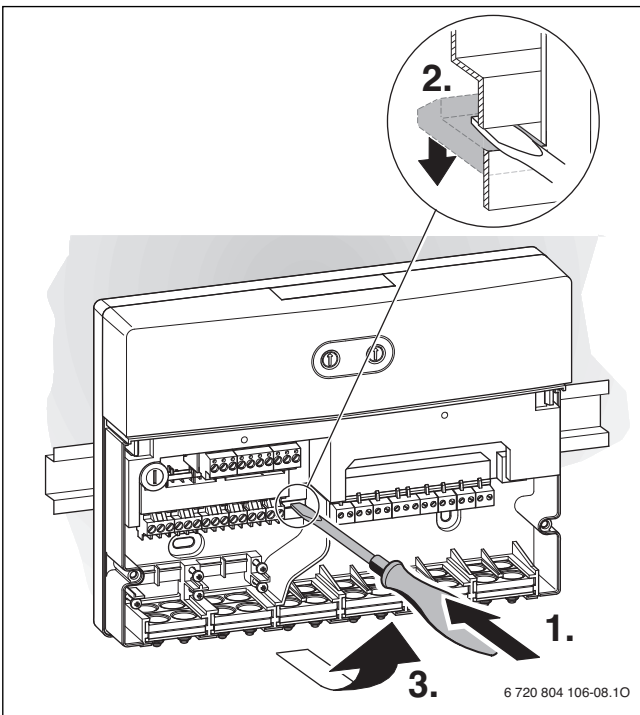

Fig. 8 Removal from DIN rail

3.2 ELECTRICAL CONNECTIONS

! DANGER: Risk of electric shock!

► Secure together the wires of every cable connected. This can be done by stripping a short section of cable sheath or with cable ties close to the terminals (→ fig. 9).

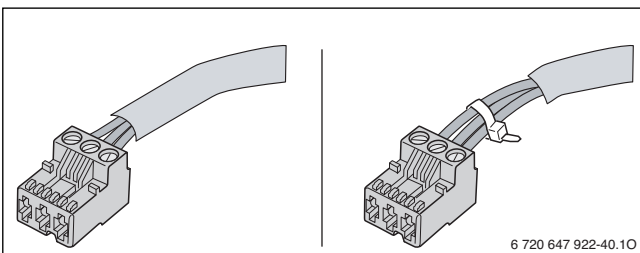

Fig. 9 Secure together the wires of every cable connected.

► Observe current regulations applicable to power connections, and use at least cable type H05 VV-...

3.2.1 CONNECTION OF BUS AND TEMPERATURE SENSOR (≤ 24 V)



If the maximum cable length of the BUS connections between all BUS subscribers is exceeded or if the BUS system is realised as a ring structure, the system cannot be commissioned.

Maximum total length of BUS connections:

- 100 m at 0.50 mm² conductor cross-section
- 300 m at 1.50 mm² conductor cross-section

- All LV leads must be routed separately from cables carrying mains voltage to avoid inductive interference (minimum separation 100 mm).
- In the case of inductive external interference (e.g. by PV systems), use shielded cables (e.g. LiYCY) and earth the shield on one side. Do not connect the shield to the grounded terminal of the module, but to a building ground terminal, e.g. a free ground terminal or a water pipe.
- Connect 1 pair of BUS terminals (BUS 1 and BUS 2) to the BUS terminals of the boiler.
- Connect the cylinder temperature sensor supplied to the terminal TC1.



For hot water cylinders without sensor pockets, use the cylinder sensor retaining device to mount the cylinder temperature sensor securely to the side of the cylinder.

When sensor leads are extended, apply the following lead cross-sections:

- Up to 20 m with 0.75 mm² to 1.50 mm² conductor cross-section
 - 20 m up to 100 m with 1.50 mm² conductor cross-section
- Route cables through the grommets provided and connect them as described in chapter 3.2.3.

3.2.2 CONNECTION TO MAINS POWER, PUMP AND VALVES (230 V AC)



The connection to mains power, pump and valves may differ depending on the system installed. The following description is a suggestion how to carry out the electrical connection of the module.



DANGER: Risk of electric shock!

If the heating system is wired in such a way that the Greenstar wiring centre and boiler have separate points of isolation (→ fig. 10, page 6):

- Attach a warning label to each point of isolation. This label has to advise that it is not the sole point of isolation and it has to identify the location of the other means of isolation.
- Electrically isolate the boiler and system components. Secure against unintentional reconnection and make sure the power supply is disconnected.

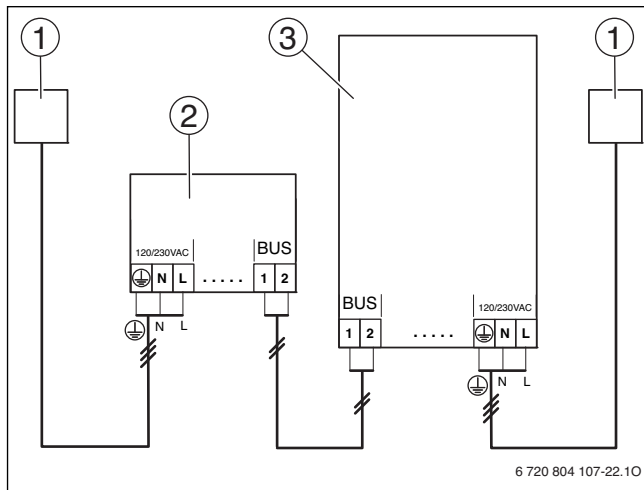

Fig. 10 Separate points of isolation

- [1] Fused spur
- [2] Greenstar Wiring Centre
- [3] Greenstar boiler¹⁾



Never exceed the maximum power consumption of the system components as specified (→ chapter 2.3, page 3).

► As the power supply is not provided via the electronic circuitry of the heating appliance, install a circuit breaker complying to the applicable standards to interrupt all phases of the power supply (acc. to EN 60335-1).

To do the electrical connections the cover of the module has to be removed.

- Only use cable of comparable quality.
- Ensure the power supply is connected to the Live, Neutral and Earth terminals.

ELECTRICAL CONNECTION - STEP 1

1. Remove grommets from the module.
2. Route cable through a grommet.
3. Remove plug from the socket.
4. Connect cable to plug and ensure it is connected to the right terminals (→ chapter 3.2.3).
5. Route cable through the same grommet.
6. Remove plug from the socket.

7. Connect cable to plug and ensure it is connected to the right terminals (→ chapter 3.2.3).

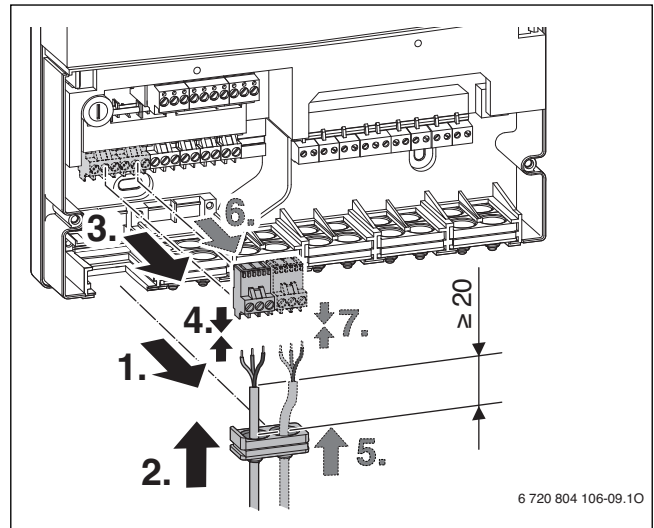

Fig. 11 Electrical connection - step 1

ELECTRICAL CONNECTION - STEP 2

1. Put the grommet used in step 1 into the socket.
2. Plug in first connected plug from where it was removed.
3. Plug in second connected plug from where it was removed.

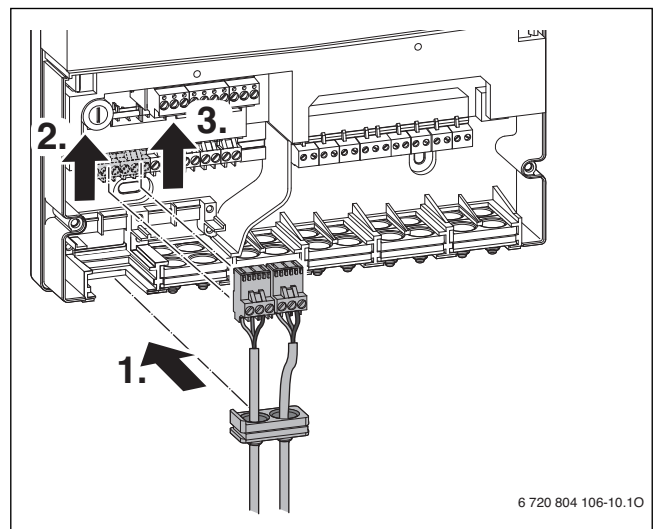

Fig. 12 Electrical connection - step 2

ELECTRICAL CONNECTION - STEP 3

1. Remove grommets from the module.
2. Route cable through a grommet.
3. Remove plug from the socket.
4. Connect cable to plug and ensure it is connected to the right terminals (→ chapter 3.2.3).
5. Route cable through the same grommet.
6. Remove plug from the socket.

1) Refer to the Installation, Commissioning and Servicing instructions of the compatible Greenstar boiler for specific wiring connections of the boiler.

7. Connect cable to plug and ensure it is connected to the right terminals (→ chapter 3.2.3).

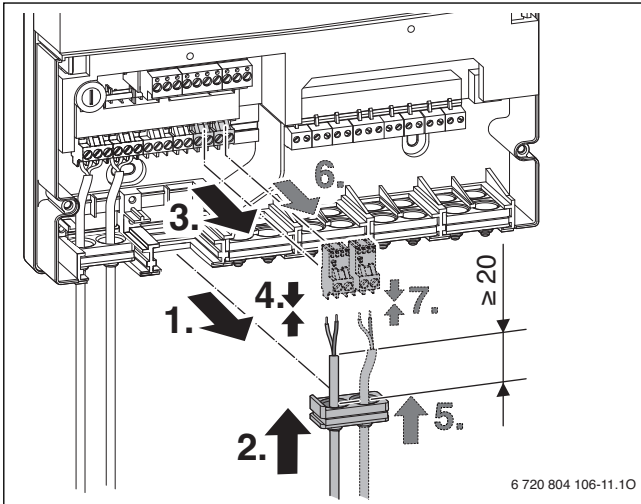

Fig. 13 Electrical connection - step 3

ELECTRICAL CONNECTION - STEP 4

1. Put the grommet used in step 3 into the socket.
2. Plug in first connected plug from where it was removed.
3. Plug in second connected plug from where it was removed.

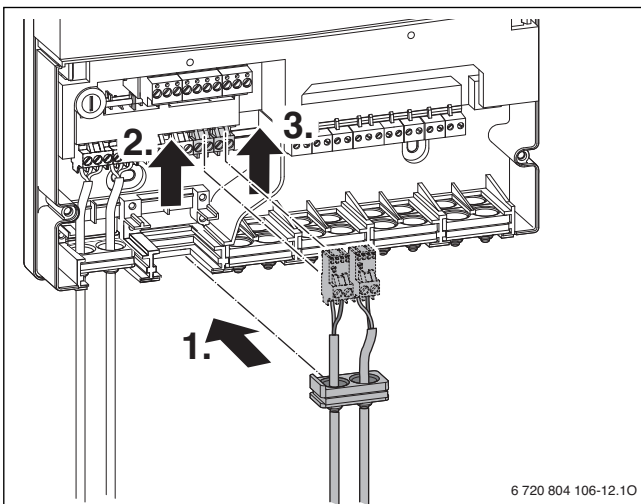

Fig. 14 Electrical connection - step 4

ELECTRICAL CONNECTION - STEP 5

- ▶ Secure cables connected in steps 1 - 4 with the strain relief supplied as shown in fig. 15.

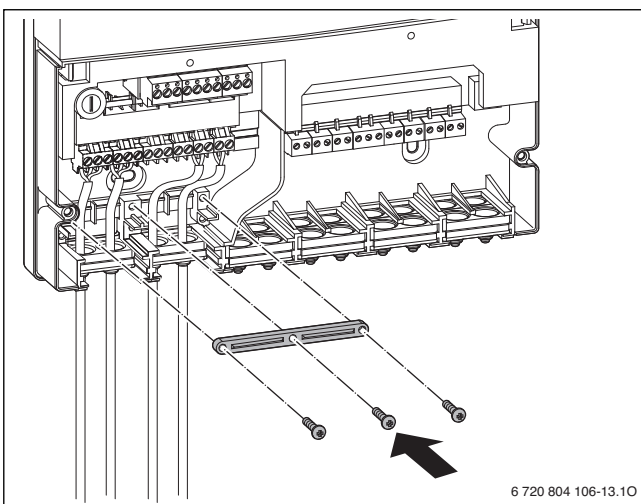

Fig. 15 Electrical connection - step 5

ELECTRICAL CONNECTION - STEP 6

1. Route cable through a grommet.
2. Remove plug from the socket.
3. Connect cable to plug and ensure it is connected to the right terminals (→ chapter 3.2.3).
4. Remove plug from the socket.
5. Connect cable to plug and ensure it is connected to the right terminals (→ chapter 3.2.3).
6. Route cable through the same grommet.
7. Remove plug from the socket.
8. Connect cable to plug and ensure it is connected to the right terminals (→ chapter 3.2.3).

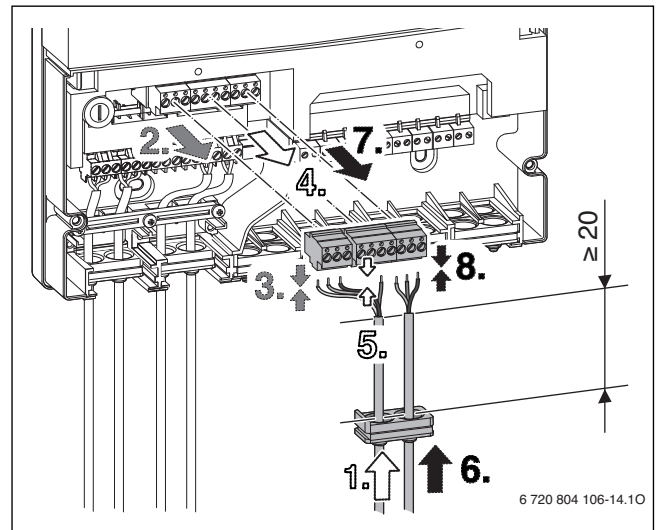

Fig. 16 Electrical connection - step 6

ELECTRICAL CONNECTION - STEP 7

- ▶ Secure cables connected in step 6 with the strain relief supplied as shown in fig. 17.

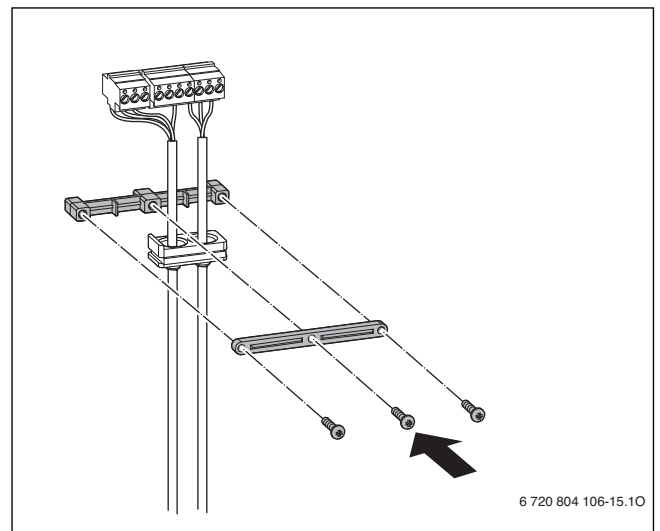

Fig. 17 Electrical connection - step 7

ELECTRICAL CONNECTION - STEP 8

1. Put the grommets into the socket.
2. Plug in first connected plug from where it was removed.
3. Plug in second connected plug from where it was removed.
4. Plug in third connected plug from where it was removed.

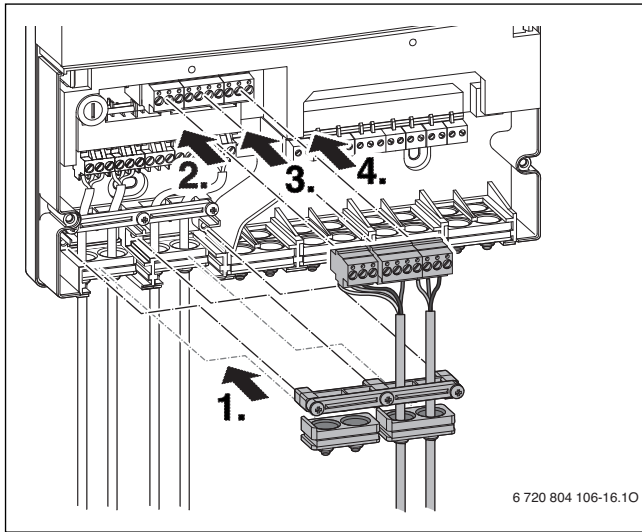

Fig. 18 Electrical connection - step 8

FITTING THE COVER

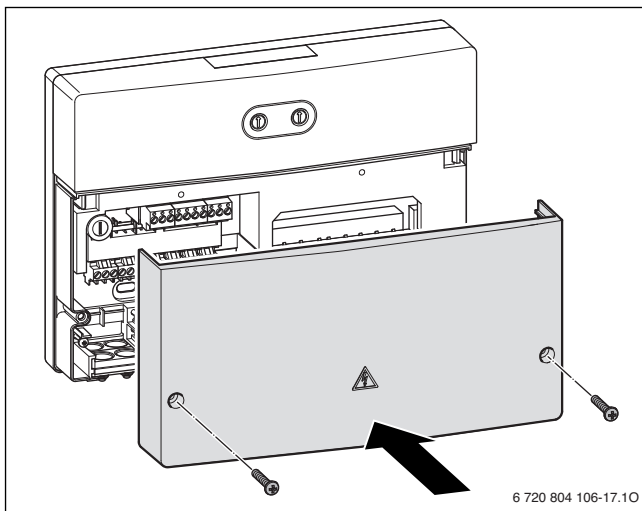

Fig. 19 Fitting the cover

3.2.3 WIRING DIAGRAMS WITH SYSTEM EXAMPLES

The circuit diagrams are only schematic illustrations and provide a non-binding indication of possible installations. Install safety equipment in accordance with applicable standards and local regulations. For further information refer to the installation instructions of the boiler and control accessory selected or for the the additional system components (not supplied by Worcester, Bosch Group) those supplied by the manufacturer.

Worcester, Bosch Group technical support may be contacted on the telephone number on the back of these instructions.

MID-POSITION (Y-PLAN) SYSTEM:

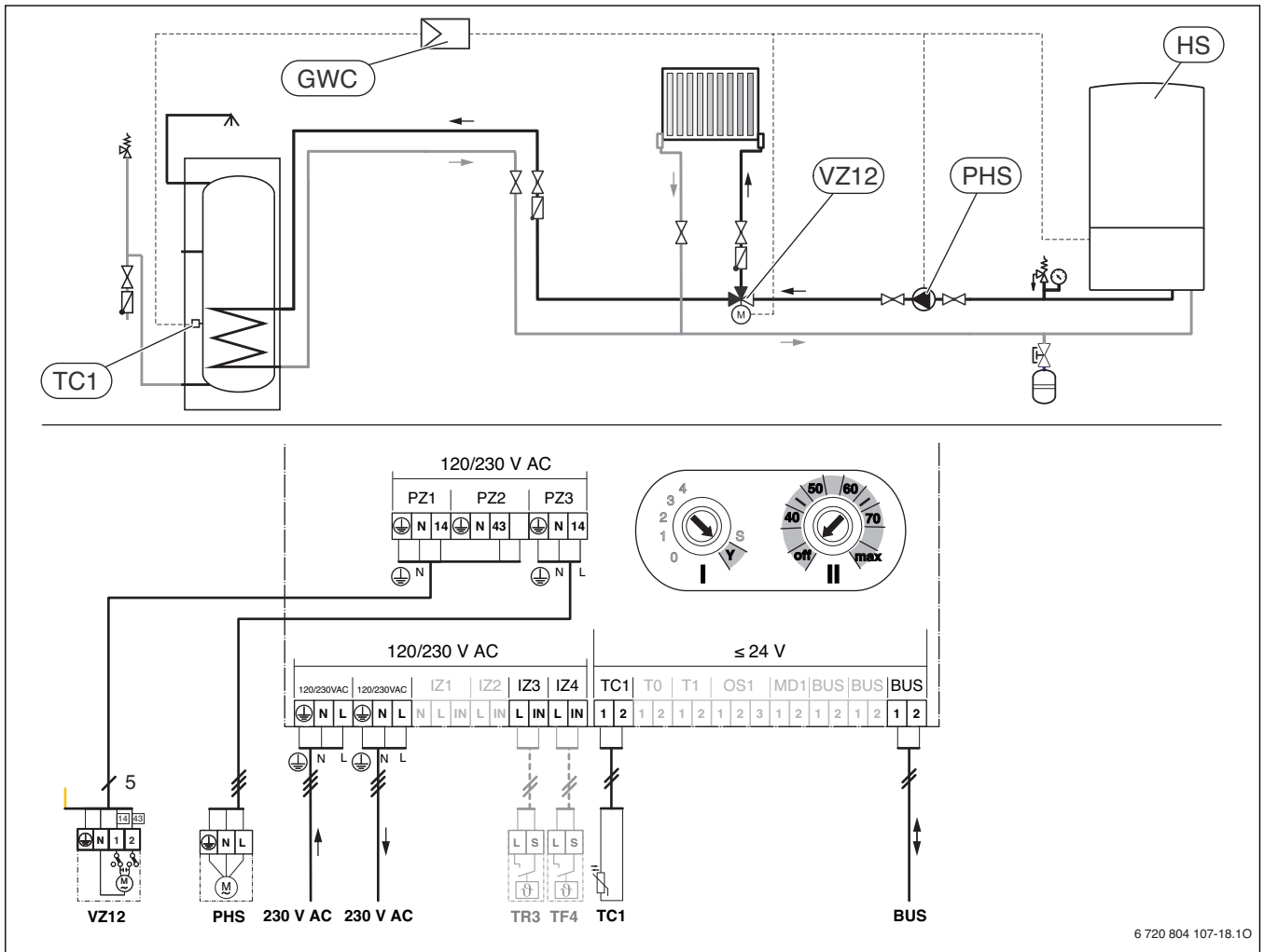

6 720 804 107-18.10

Fig. 20 Mid-position system

- ⊕ Earth conductor
- L Phase (230 V AC)
- N Neutral conductor

Switches:

- I Code switch I – system type
- II Temperature switch II – domestic hot water cylinder temperature

Terminal identification:

- 230 V AC Mains voltage
- BUS **BUS** EMS plus
- IZ1 No function
- IZ2 No function
- IZ3 Room thermostat (Input Zone; 9: Temperature/temperature sensor)
- IZ4 Frost thermostat (9: Temperature/temperature sensor)
- MD1 No function
- OS1 No function
- PZ1...2 Mid-position valve:
terminal 14: DHW off
terminal 43: heating mode
- PZ3 Circulating pump (Pump Zone)
- T0 No function
- T1 No function
- TC1 Cylinder temperature sensor (Temperature sensor Cylinder)

System component:

- 230 V AC Mains voltage
- BUS **BUS** EMS plus (connection between the Greenstar Wiring Centre and boiler)
- GWC Greenstar Wiring Centre
- HS Boiler (Heat Source)
- PHS Circulating pump (Pump Heat Source)
- TC1 Cylinder temperature sensor (Temperature sensor Cylinder)
- TR3 Room thermostat (Thermostat Room temperature); optional; not shown in fig. 20
- TF4 Frost thermostat (Thermostat Frost protection); optional; not shown in fig. 20
- VZ12 Diverter valve (Valve Zone); connect as follows:
green/yellow to: PZ1 – ⊕
blue to: PZ1 – N
grey to: PZ1 – 14
white to: PZ2 – 43
orange to: PZ2 – no lettering (no function)

TWO-PORT VALVE (S-PLAN) SYSTEM:

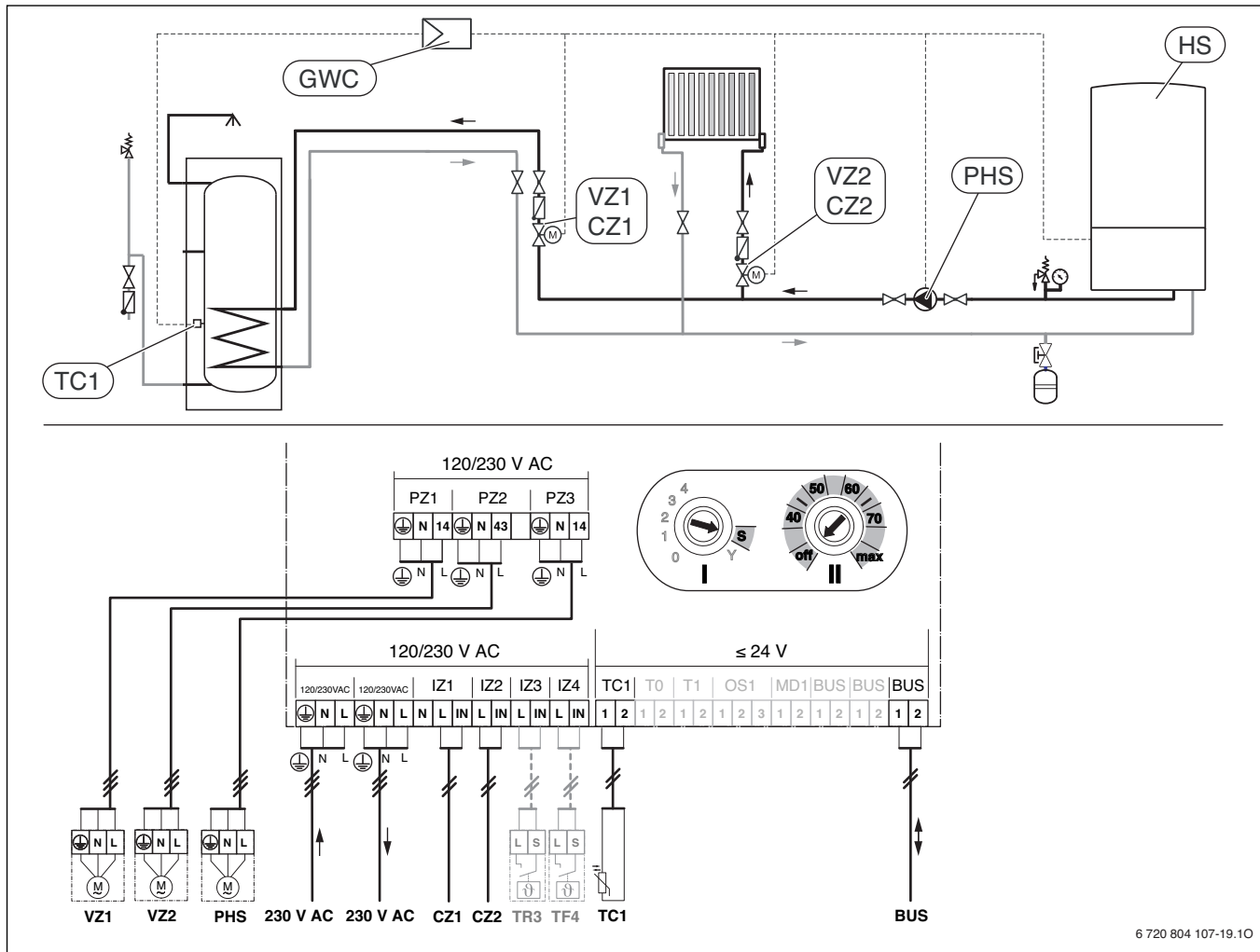

Fig. 21 Two-port valve system

- ⊕ Earth conductor
- L Phase (230 V AC)
- N Neutral conductor

Switches:

- I Code switch I – system type
- II Temperature switch II – domestic hot water cylinder temperature

Terminal identification:

- 230 V AC Mains voltage
- BUS **BUS** EMS plus
- IZ1 DHW 2-port valve end switch
- IZ2 Central heating 2-port valve end switch
- IZ3 Room thermostat (Input Zone; 9: Temperature/temperature sensor)
- IZ4 Frost thermostat (9: Temperature/temperature sensor)
- MD1 No function
- OS1 No function
- PZ1 DHW 2-port valve motor
- PZ2 Central heating 2-port valve motor
- PZ3 Circulating pump (Pump Zone)
- T0 No function
- T1 No function
- TC1 Cylinder temperature sensor (Temperature sensor Cylinder)

System component:

- 230 V AC Mains voltage
- BUS **BUS** EMS plus (connection between the Greenstar Wiring Centre and boiler)
- CZ1 2-port valve end switch, switch at valve for DHW (Contact Zone)
- CZ2 2-port valve end switch, switch at valve for central heating (Contact Zone)
- GWC Greenstar Wiring Centre
- HS Boiler (Heat Source)
- PHS Circulating pump (Pump Heat Source)
- TC1 Cylinder temperature sensor (Temperature sensor Cylinder)
- TR3 Room thermostat (Thermostat Room temperature); optional; not shown in fig. 21
- TF4 Frost thermostat (Thermostat Frost protection); optional; not shown in fig. 21
- VZ1 2-port valve for DHW (Valve Zone)
- VZ2 2-port valve for central heating (Valve Zone)

THREE CENTRAL HEATING CIRCUITS ONLY WITHOUT ELECTRONIC MIXING VALVES:

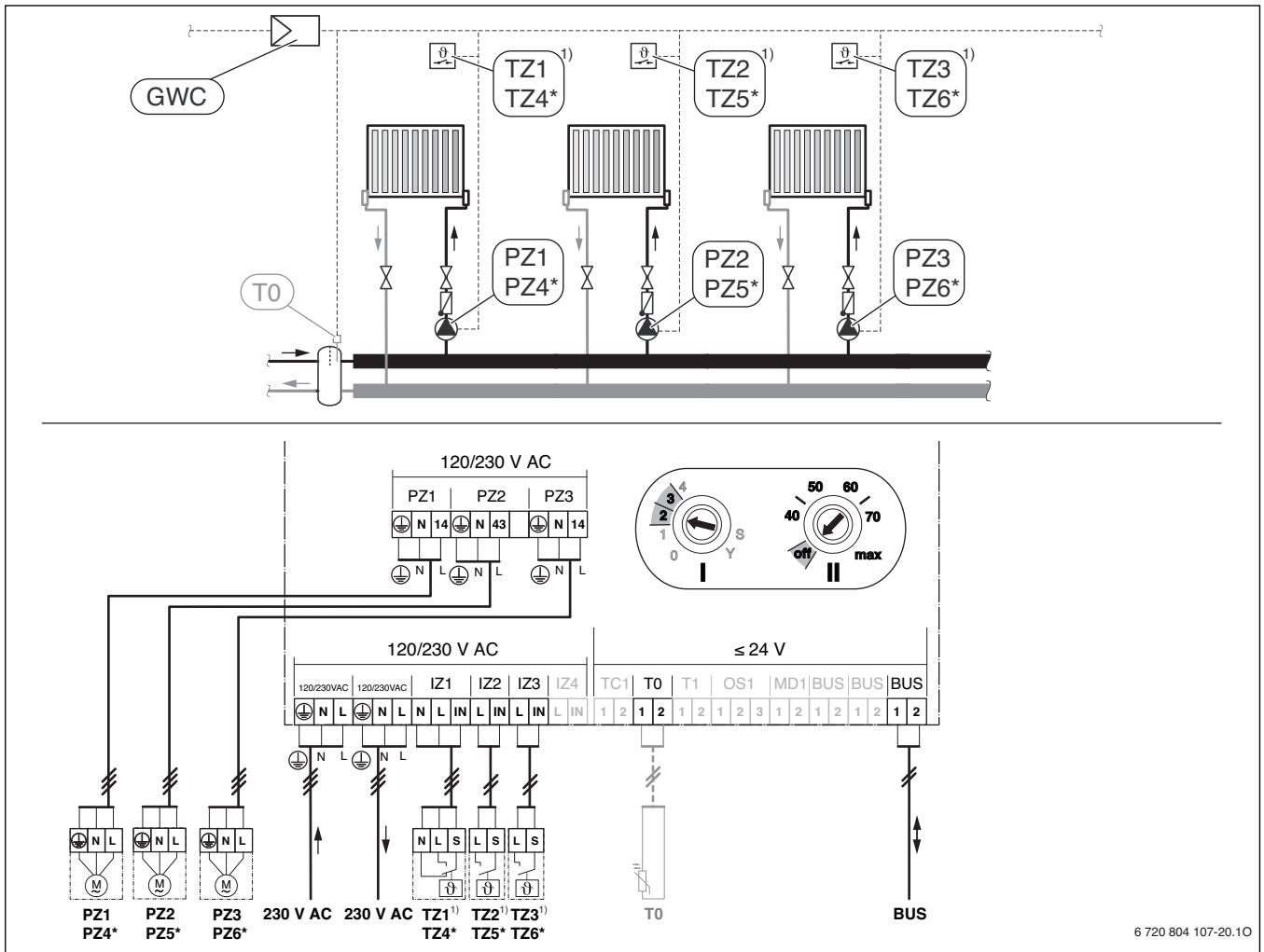

6 720 804 107-20.10

Fig. 22 Three central heating circuits without electronic mixing valves

- ⊕ Earth conductor
- L Phase (230 V AC)
- N Neutral conductor

Switches:

- I Code switch I – system type
- II Temperature switch II – domestic hot water cylinder temperature

Terminal identification:

- 230 V AC Mains voltage
- BUS **BUS** EMS plus
- IZ1...3 Room thermostat (Input Zone; 9: Temperature/temperature sensor)
- IZ4 No function
- MD1 No function
- OS1 No function
- PZ1...3 Circulating pump (Pump Zone)
- T0 Flow temperature sensor to the low-loss header (Temperature sensor); optional
- T1 No function
- TC1 No function

System component:

- 230 V AC Mains voltage
- BUS **BUS** EMS plus (connection between the Greenstar Wiring Centre and boiler)
- GWC Greenstar Wiring Centre
- PZ1...6 Circulating pump in each heating circuit (Pump Zone); allocation of heating circuits 1, 2 and 3 or 4, 5 and 6 according to coding (→ chapter 4, page 13)
- T0 Flow temperature sensor at low-loss header (Temperature sensor); optional
- TZ1...6 Room thermostat (Thermostat room temperature Zone; 9: Temperature/temperature sensor); allocation of heating circuits 1, 2 and 3 or 4, 5 and 6 according to coding (→ chapter 4, page 13)

- *) The marked system components are connected to the module with coding 3 (coding → chapter 4, page 13).
- 1) Each of the thermostats TZ1...6 must be of a “programmable room thermostat” type and compatible with 230 V AC operation. Observe the coding of the modules (→ chapter 4, page 13).

TWO CENTRAL HEATING CIRCUITS WITHOUT ELECTRONIC MIXING VALVES AND ONE DOMESTIC HOT WATER CYLINDER CIRCUIT:

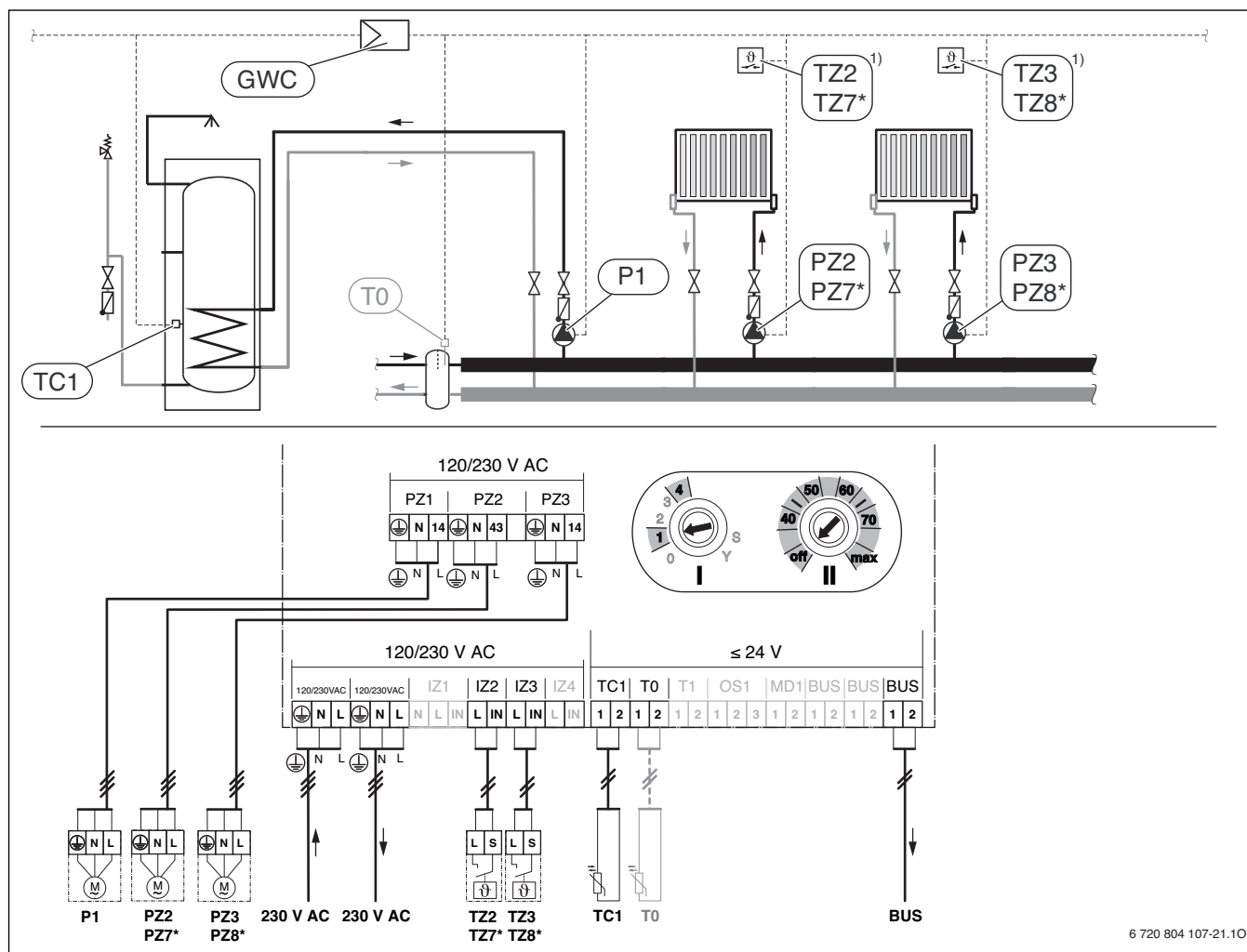

Fig. 23 Two heating circuits and one domestic hot water cylinder circuit

- ⊕ Earth conductor
- L Phase (230 V AC)
- N Neutral conductor

Switches:

- I Code switch I – system type
- II Temperature switch II – domestic hot water cylinder temperature

Terminal identification:

- 230 V AC Mains voltage
- BUS **BUS** EMS plus
- IZ1 No function
- IZ2...3 Room thermostat (**Input Zone**)
- IZ4 No function
- MD1 No function
- OS1 No function
- PZ1 Cylinder primary pump
- PZ2...3 Circulating pump or (**Pump Zone**)
- T0 Flow temperature sensor to the low-loss header (**Temperature sensor**); optional
- T1 No function
- TC1 Cylinder temperature sensor (**Temperature sensor Cylinder**)

System component:

- 230 V AC Mains voltage
- BUS **BUS** EMS plus (connection between the Greenstar Wiring Centre and boiler)
- GWC Greenstar Wiring Centre
- P1 Cylinder primary pump (**Pump DHW**)
- PZ2...8 Circulating pump in each heating circuit (**Pump Zone**); allocation of heating circuits 2 and 3 or 7 and 8 according to coding (→ chapter 4, page 13)
- T0 Flow temperature sensor at low-loss header (**Temperature sensor**); optional
- TC1 Cylinder temperature sensor (**Temperature sensor Cylinder**)
- TZ2...8 Room thermostat (**Thermostat room temperature Zone**); allocation of heating circuits 2 and 3 or 7 and 8 according to coding (→ chapter 4, page 13)

- *) The marked system components are connected to the module with coding 4 (coding → chapter 4, page 13).
- 1) Each of the thermostats TZ2...8 must be of a “programmable room thermostat” type and compatible with 230 V AC operation. Observe the coding of the modules (→ chapter 4, page 13).

4 COMMISSIONING



First make all electrical connections and then carry out the commissioning!

- ▶ Follow all installation instructions of all components and assemblies belonging to the system.
- ▶ Ensure that no two modules share the same coding.
- ▶ If several modules are used, ensure that the code switch I of none of the module is set to **1**.
- ▶ Do not switch on the power supply until all modules are set up.



NOTICE: When switching the system on, the connected pump may start immediately, this is part of the start-up process and does not indicate an error.

- ▶ Ensure that the system is filled before switching the system on to ensure that the pump does not run dry.

CODE SWITCH I

The system type is set on the module using **code switch I**:

- Mid-position (Y-plan) system: code switch I set to **Y**
- 2-port valve (S-plan) system: code switch I set to **S**
- Three central heating circuits without electronic mixing valves:
 - Module for heating circuits 1, 2 and 3 = set code switch I to **2**
 - Module for heating circuits 4, 5 and 6 = set code switch I to **3**
- Two central heating circuits without electronic mixing valves and one domestic hot water cylinder circuit:
 - Module for heating circuit 2, 3 and domestic hot water cylinder circuit (only one module is permissible in the system) = set code switch I to **1**
 - Module for heating circuits 7, 8 and domestic hot water cylinder circuit (one of a maximum of three modules in the system) = set code switch I to **4**

TEMPERATURE SWITCH II



WARNING: Risk of scalding!

- ▶ A mixer device must be installed if water temperatures higher than 60 °C are set.

The **target domestic hot water cylinder temperature** is adjusted at the **temperature switch II**:

- The target domestic hot water cylinder temperature can be set in increments of 5 °C between 40 °C and 70 °C: set temperature switch to **40 to 70** as required by the customer.
- A maximum target domestic hot water cylinder temperature of 75 °C is available: set temperature switch to **max** (two valid switch positions)

SYSTEM AND MODULE COMMISSIONING

1. Set the system type for the module using the code switch **I**.
2. Set the cylinder temperature using temperature switch **II**.
- or-
Set temperature switch **II** to **off**
3. If applicable, adjust the positions of code switch and temperature switch at the other modules.
4. Switch on the power supply (230 V AC) of the entire system, the Greenstar Wiring Centre and the boiler.

When the status indicator of module lights up green:

5. Commission and set up the boiler and control accessory in accordance with the installation instructions supplied with those products.

5 TROUBLESHOOTING



Only use original spare parts. Damage caused by the use of spare parts not approved for this product by the manufacturer are excluded from our guarantee.

5.1 STATUS INDICATOR

The indicator shows the operating condition of the module.

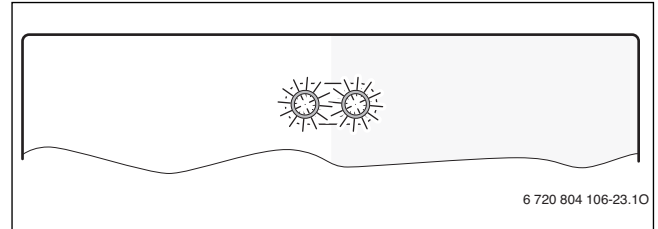

Fig. 24 Module status indicator

Indicator	Possible cause	Remedy
lights off continuously (at code switch I)	Code switch set to 0	▶ Set code switch (→ chapter 4, page 13).
	Power supply interrupted.	▶ Switch ON power supply.
	Fuse is defective	▶ Ensure that power supply is isolated and replace fuse (→ chapter 5.2 and fig. 25 on page 14).
	Short circuit in the BUS connection	▶ Check BUS connection and repair if required.
Lights up red continuously (at code switch I)	Internal fault	▶ Replace module.
Flashes red (at code switch I or temperature switch II)	Code switch in invalid position or in intermediate position	▶ Set code switch (→ chapter 4, page 13).
Flashes green (at code switch I)	Maximum cable length for BUS connection exceeded.	▶ Make shorter BUS connection.
	Temperature sensor is faulty.	▶ Replace temperature sensor.
Lights up green continuously (at code switch I)	No fault	Standard operation.

Table 4 Troubleshooting

5.2 REPLACING THE FUSE



DANGER: Risk of electric shock!

- ▶ Electrically isolate the boiler and system components. Secure against unintentional reconnection and make sure the power supply is disconnected.

To replace the fuse the cover of the module has to be removed.

1. Release fuse.
2. Take defective fuse out of fuse socket.
3. Dispose of defective fuse.
4. Replace fuse into fuse socket.
5. Secure fuse.

6. Fit the cover.

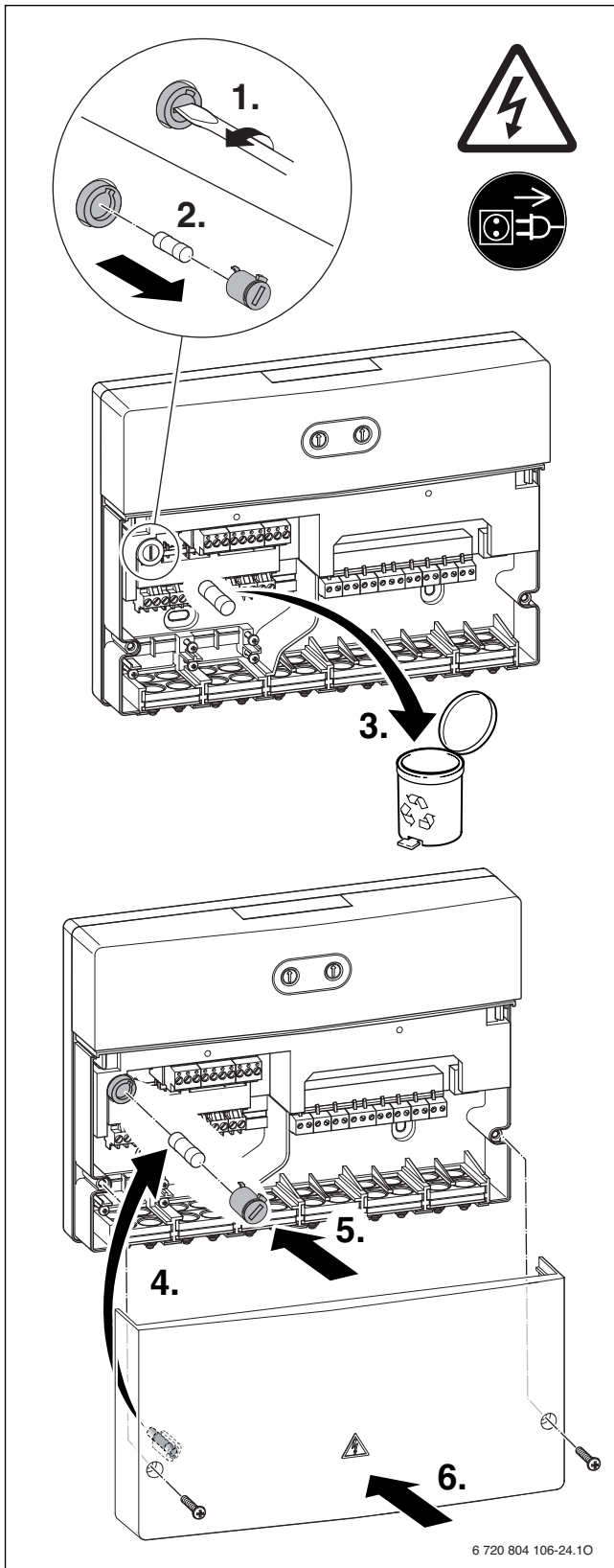

Fig. 25 Replace fuse

6 ENVIRONMENT / DISPOSAL

Environmental protection is a fundamental corporate strategy of the Bosch Group.

The quality of our products, their economy and environmental safety are all of equal importance to us and all environmental protection legislation and regulations are strictly observed.

We use the best possible technology and materials for protecting the environment taking account of economic considerations.

PACKAGING

We participate in the recycling programmes of the countries in which our products are sold to ensure optimum recycling.

All of our packaging materials are environmentally compatible and can be recycled.

USED APPLIANCES

Used appliances contain valuable materials that should be recycled.

The various assemblies can be easily dismantled and synthetic materials are marked accordingly. Assemblies can therefore be sorted by composition and passed on for recycling or disposal.

NOTES

Worcester, Bosch Group
Cotswold Way, Warndon, Worcester WR4 9SW.
Tel. 0844 892 9900

Worcester, Bosch Group is a brand name of Bosch Thermotechnology Ltd.
worcester-bosch.co.uk

6 720 804 107

WORCESTER, BOSCH GROUP:

TECHNICAL SUPPORT:	0844 892 3366
APPOINTMENTS:	0844 892 3000
SPARES:	01905 752571
LITERATURE:	0844 892 9800
TRAINING:	01905 752526
SALES:	01905 752640



WORCESTER
Bosch Group