

Drayton

MiTime™ Programmer Series RF Packs

Single Channel: MiTime T710R

Dual Channel: MiTime T720R, T720M

Multi Channel: MiTime T740R, T740M

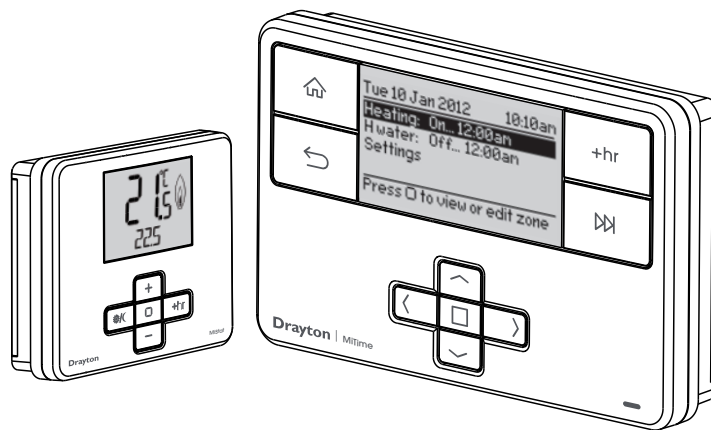

Invensys

Customer Service Tel: 0845 130 5522

Customer Service Fax: 0845 130 0622

Technical Helpline: 0845 130 7722

Website: www.draytoncontrols.co.uk

E-mail: customer.care@invensys.com

 @DraytonControls

 /DraytonControls

EU Design Regs:- 002180638-1/2/3

Installer Guide 06490194001 Iss F



 **INSTALLATION Guide**

Step 1: Mounting the Wall-plate



⚠ **IMPORTANT:**

Installation must only be carried out by a qualified electrician or heating engineer.

Make sure mains input has a 3 amp fuse.

⚠ **CAUTION!** Before installation, make sure the mains supply is switched off!

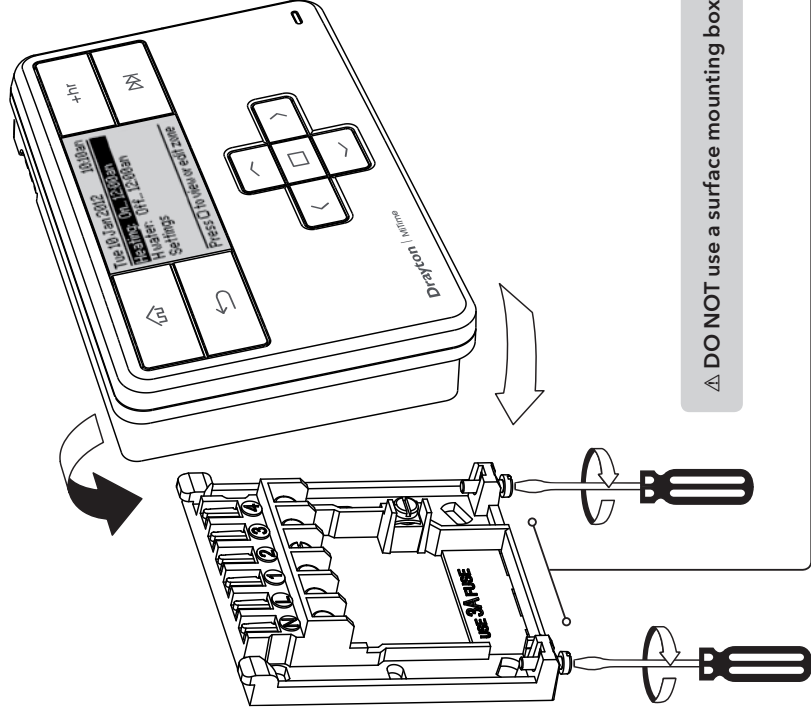

Option 1: Fitting a new wall-plate

The ideal location is 1.2m above floor level, with reasonable lighting, good access, no condensation, no extremes of temperature and a supporting surface that fully covers the back of the unit. Position with 70mm clearance to the right, 25mm above and sufficient room to access the securing screws underneath. Fix, with terminals at the top, either direct to a flat wall using wall plugs and No. 6 x 1" (25mm) woodscrews, or on a flush mounting single conduit box type UA1 (BS4662) using M3.5 x 14 bolts. Check the 3A fuse, and switch on the mains.

Option 2: Using an existing wall-plate

Loosen the securing screws on the old programmer and unplug it. Check that there is 70mm clearance to the right of the wall-plate and 25mm above it. Check the wiring diagram for your product model to compare terminals and, if necessary, change the wiring of the wall-plate to suit. Now plug the MITime unit into the wall-plate and tighten the securing screws.

⚠ **DO NOT** use a surface mounting box

Check the 3A fuse, and switch on the mains.

Step 2: Wiring

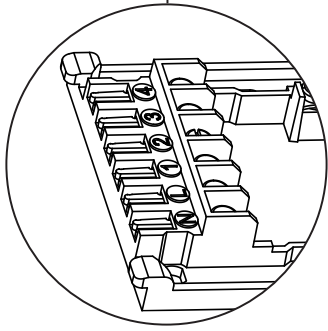

Single Channel:
MiTime T710R

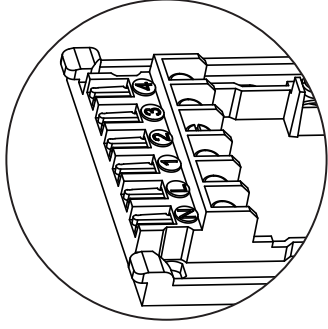
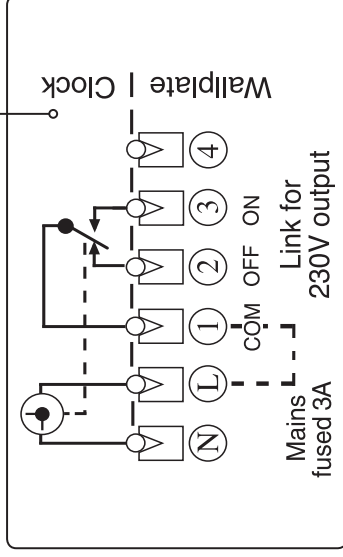

Dual Channel:
MiTime T720R, T720M

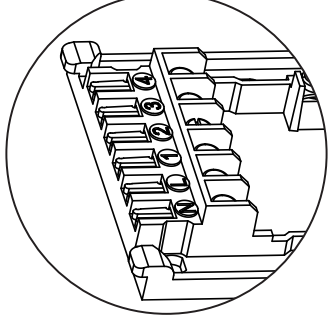
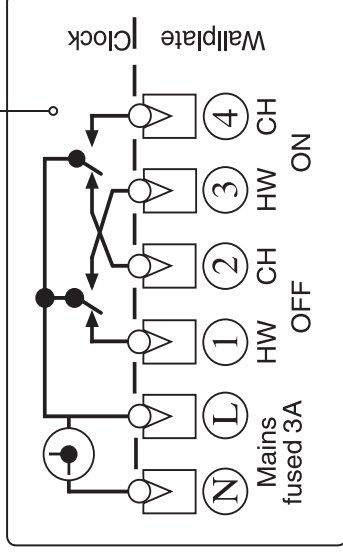

Multi Channel:
MiTime T740R, T740M

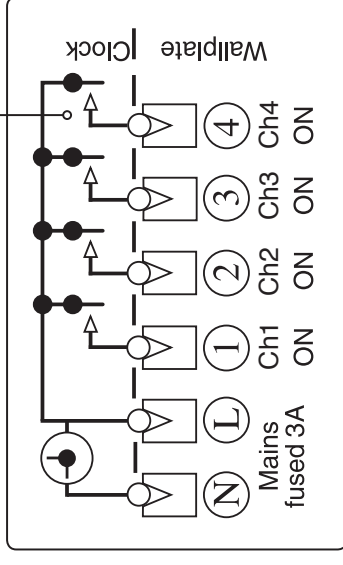

Connect the wiring as shown above.

T710R only: Note that the output contacts are voltage-free, so power needs to be put on to Terminal 1 either by linking from Terminal L or from a separate supply with a 3A fuse.

IMPORTANT:

Always switch off the mains before removing the MiTime programmer - and never fit it to a live wall-plate!

Step 3: Wireless Thermostats - Checking the batteries →

How do I know when to change the batteries?

When the batteries start to run low a battery icon will flash in the display, to indicate "low battery" during this time the MiStat will function normally (see fig 1). Please replace batteries with 2 x 1.5V IEC LR6 (AA) Alkaline batteries. When the battery icon alone is shown in the display, the batteries are completely exhausted and the MiStat will cease to function (see below). Re-activate by replacing the batteries.

How to replace the batteries

Remove the battery covers using a coin. Replace the spent batteries with 2 x 1.5V IEC LR6 (AA) Alkaline batteries ensuring correct orientation. Replace the battery covers pressing fully home.

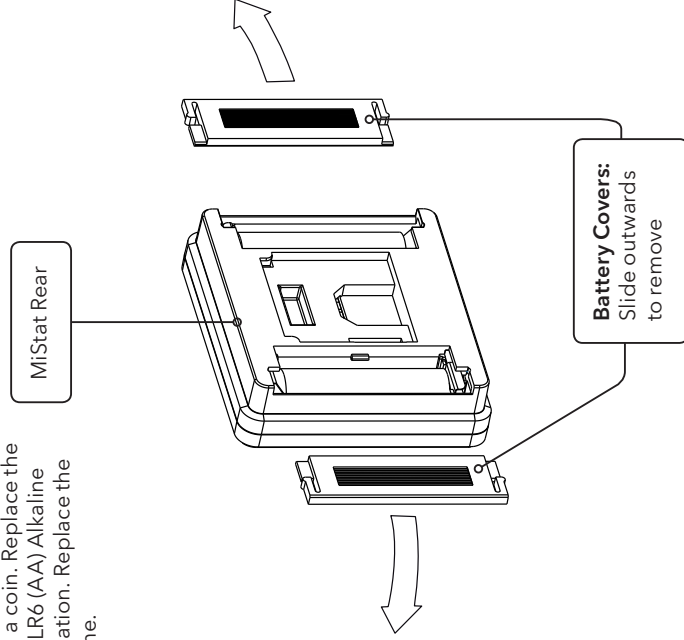
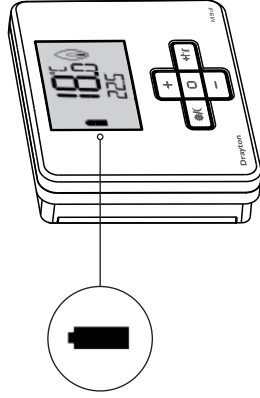

Battery Handling

Batteries, rechargeable or not, should not be disposed of into ordinary household waste. Instead, they must be recycled properly to protect the environment and cut down the waste of precious resources.

Your local waste management authority can supply details concerning the proper disposal of batteries.

In compliance with the EU Directive 2006/66/EC, the button cell battery located on the printed circuit board inside the product, can be removed at the end of the product life, by professional personnel only.

Step 4: Signal Strength →

The MiStat Room & Cylinder thermostats are pre-bound to the MiTime programmer in the factory so they just need to be positioned in the best place for wireless communication. To help with this there is a built in Signal strength indicator, available in the Installer settings menu on the MiTime programmer, as shown. It is recommended that the signal strength is Good or Very Good to ensure ongoing communication is maintained.

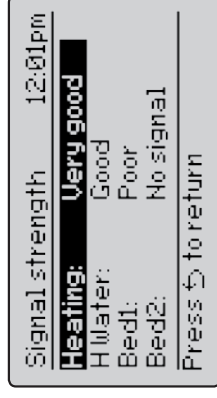

The signal strength can also be seen on the MiStat thermostat.

To enter signal strength menu

- Press + & - for approx. 5 secs, then scroll (+/-) to show INST-S,
- press (D) to enter the installer menu,
- Press +/- until 11 WIRELESS is shown,
- press (D) to enter,
- press +/- to show 13 SIG-LEVEL as shown,
- press (D) to see the current signal strength.

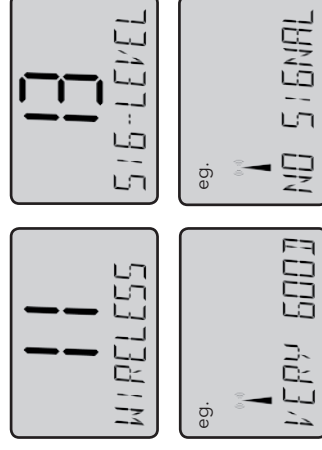

If POOR is displayed, look for a better location
If NO SIGNAL is displayed, try connecting again with the room unit in a different position

Step 5: Mounting Options →

Once the best position has been identified, the MiStat should be fixed to the wall using the wall bracket as shown.

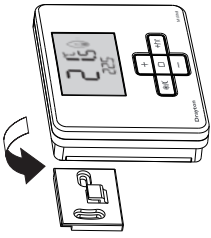

Care should be taken to mount the thermostat in a position which is not subject to direct sunlight or draughts. Preferably it should be mounted on an inside wall about 1.2m (4ft) above the floor in a position where it can respond to room temperature but away from the direct influence of radiators or other appliances giving off heat.

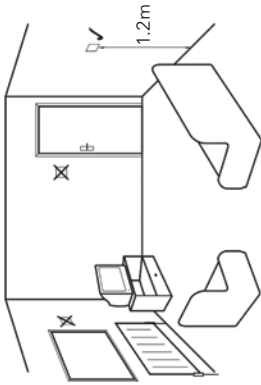

NB. MiStat can also be positioned using the table stand included.

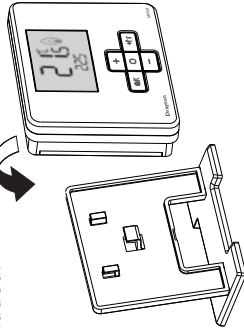

It has to be placed in a location where it will be able to control the room temperature.

Step 6: Cylinder Sensor (T720M, T740M only) →

Wiring

Cylinder Thermostat

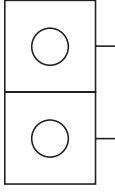

External Sensor

Cylinder Thermostat Sensor

Locate the external sensor terminal block on the lower edge of the MiStat C thermostat, connect a 2-core cable, cut to the required length to reach the sensor position. Connect to the sensor in the position shown and fold wires back through the cable grip & out through the cable entry, re-assemble the housing.

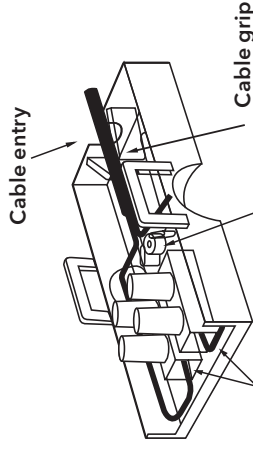

Connect here NTC Sensor

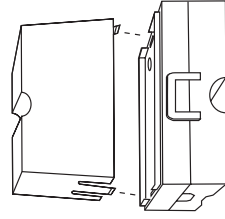

Clip the spacer provided onto the sensor housing

The sensor should be installed approximately one third of the way up the hot water cylinder. With pre-insulated cylinders, mark the position and size, and remove just enough insulation to allow the sensor to fit against the metal of the cylinder in the recess formed.

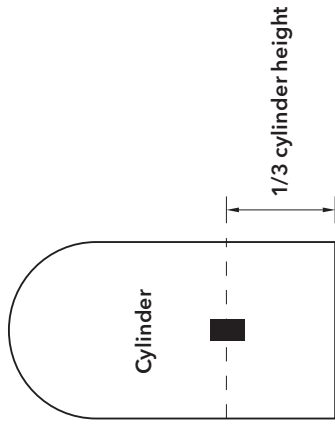

The plastic covered spring fixing cable should be cut to an un-stretched length of approximately 60-75mm (2½"-3") less than the circumference of the cylinder and the hook and eyelet should be screwed into the ends. Stretch the cable round the cylinder, over the insulation, and position it in the groove across the front of the sensor housing, Engage the hook and eyelet.

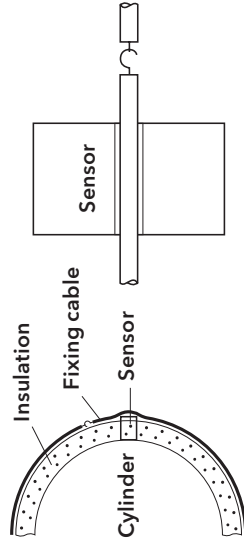

Step 7: Connection Charts

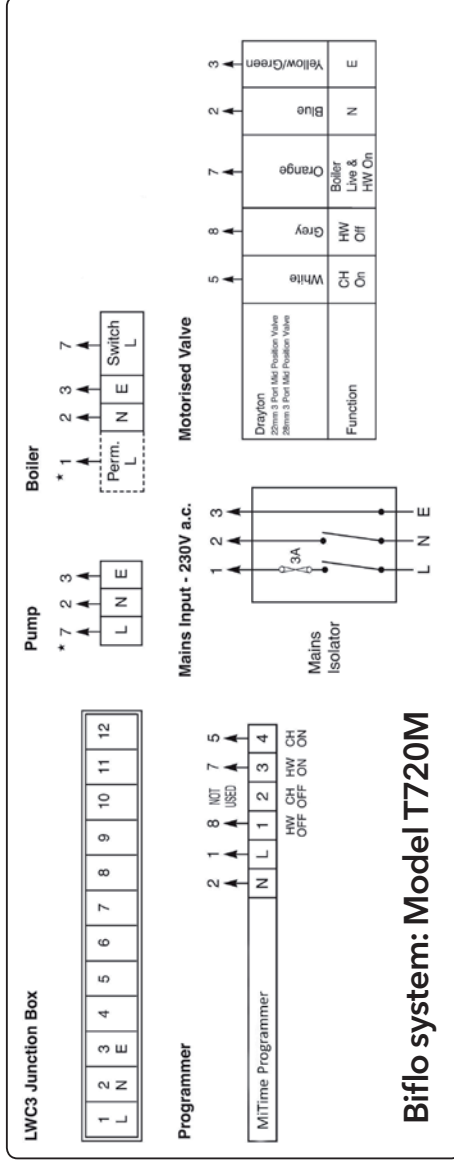
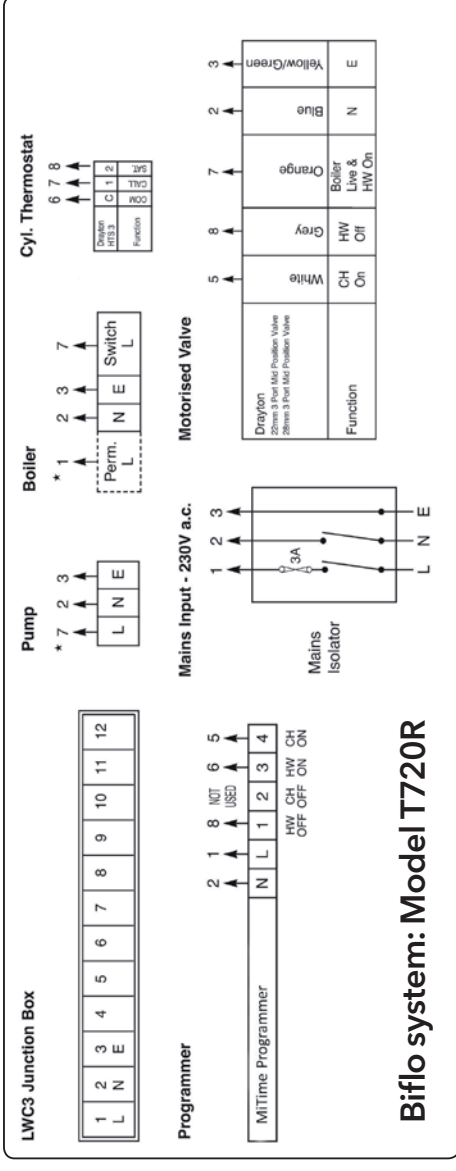

Arrowed numbers relate to the junction box.
* Consult boiler handbook for details of pump overrun wiring.

IMPORTANT:

Always switch off the mains before removing the MiTime programmer - and never fit it to a live wall-plate!

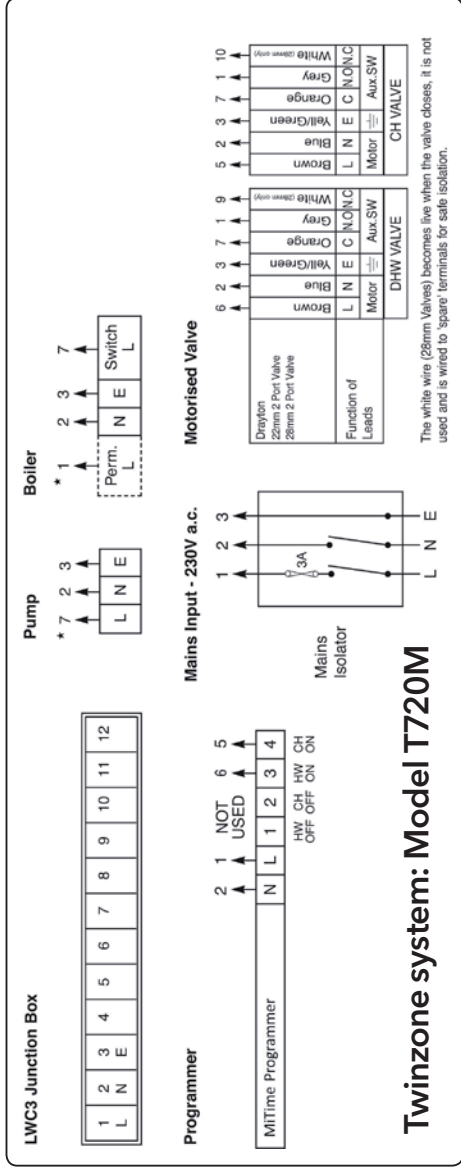
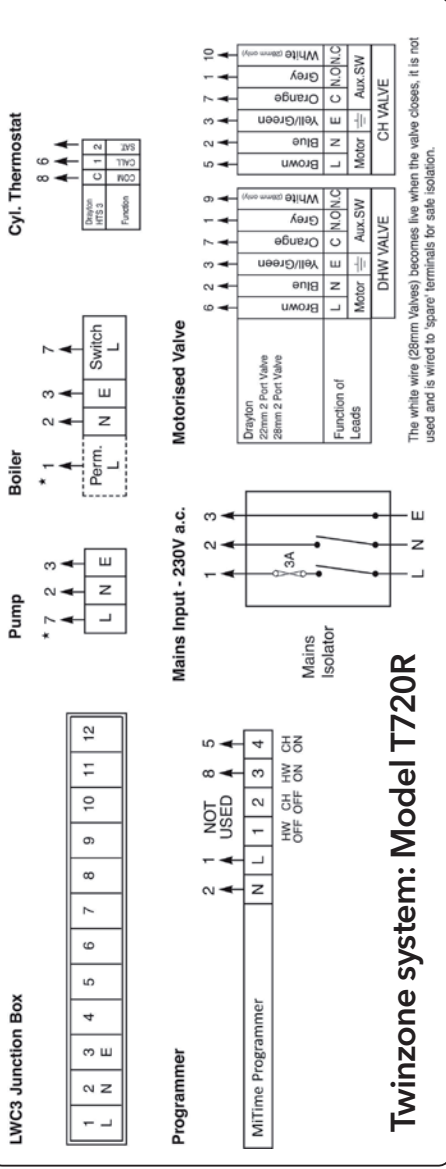

Make the wiring connections, as above, for the appropriate system. For surface wiring, snap out the cable entry strip on the bottom edge of the wall-plate. MiTime units are double-insulated and need no earth connection, but an earthing continuity (loop) terminal is provided for convenience.

After wiring, plug in the unit and tighten the securing screws. Check the mains input has a 3A fuse, and switch on the mains.

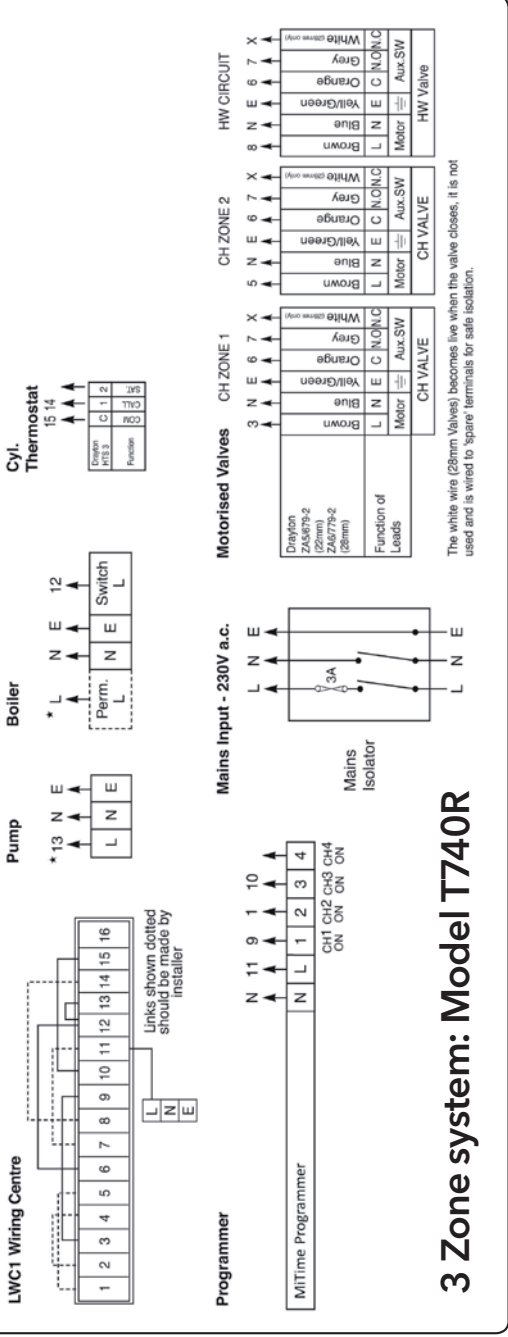

3 Zone system: Model T740R

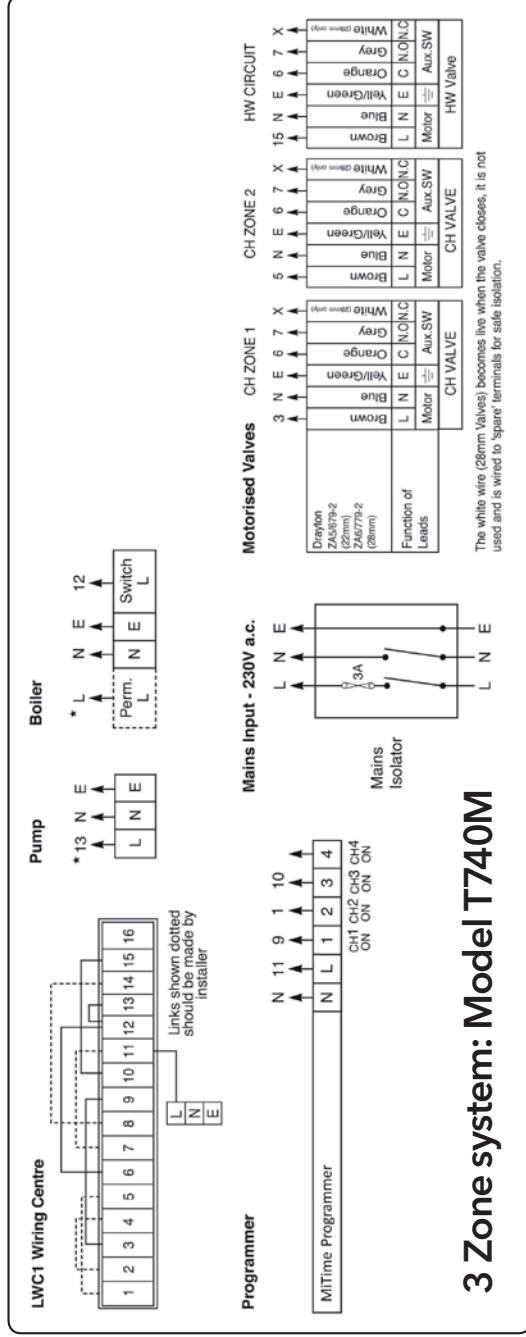

3 Zone system: Model T740M

Step 8: Installer Settings

From the Home screen, select **Settings**, then **Installer settings** as shown.

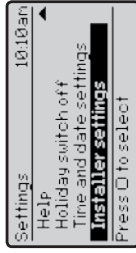
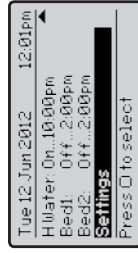

From here you can edit the assigned zones, rename them if required and adjust the Service settings.

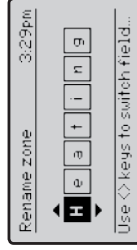
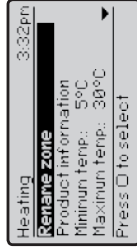
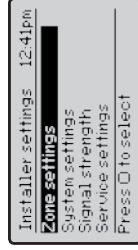

If using the Service feature, remember to set the **Password** when complete.

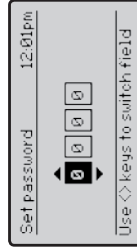
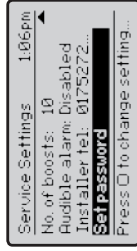
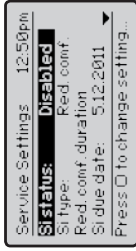
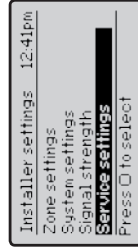

Feature:	Description:	Factory Pre-Set:
Installer Settings	⚠ CAUTION! These settings should only be modified by a qualified person. They can influence safety and the proper functioning of the system.	
Zone Settings	Customise the MiTime according to personal requirements These are settings which will be applied to a connected room/cylinder stat.	
Select zone	Select a zone for the following actions	
Rename zone	To rename an existing zone	Heating, H/Water, Bed 1
View Product Information	View the product details, e.g. Part number, Firmware revision etc.	
Minimum temp	It will not be possible to set a lower temperature	5C (Cyl stat = 40C)
Maximum temp	It will not be possible to set a higher temperature	30C (Cyl stat = 70C)
Eco temp.	Temperature used for energy saving periods e.g. during the night	16C (Cyl stat = N/A)
Comfort temp.	Temperature used for comfort periods e.g. during the day	21C (Cyl stat = N/A)
Backlight settings	Available options are: On with timeout, Always Off	On with timeout
Temp. offset	Adjust the displayed temperature to personal needs	0C (Cyl stat = N/A)
Screen lock	Enable or disable the lock in the room unit To Lock: Enter a 3 digit code for protection To Unlock: Enter the 3 digit code	000 Master Code 401
RF Binding	Bind the remote thermostat to the receiver.	Pre-bound
Delete zone (not T710R)	To delete an existing zone. The last zone cannot be deleted	Min. 1 Zone
Add Zone (not T710R)	Add a new zone, apply a name & bind a thermostat. A time table can be applied.	T720: Max. 2 Zones T740: Max. 4 Zones
System Settings	These are the settings which will be applied to the MiTime unit	
View product information	View the product details, e.g. Part number, Firmware revision etc.	
Backlight settings	Available options are: On with timeout, Always On, Always Off	On with timeout
Control type *Heating zones only	Select TPI, TP or On/Off	TPI
Cycle rate (*only when Control type is TPI or TP)	Select 3 cph (cycles per hour), 6 cph or 12 cph	6 cph

Technical Data



Feature:	Description:	Factory Pre-Set:
Min on/off (*only when Control type is On/off)	Select 1 min., 3 min., 5 min. or 10 min.	1 min.
Hysteresis (*only when Control type is On/off)	Enable or disable Hysteresis	Disabled
Frost Protection *Heating zones only	Enable or disable the Frost protection in the MiTime unit.	Disabled
Valve protection	The output will be activated for the specified time (in minutes). This will happen weekly, related to the last actuation of the output. Select 0 to 10 minutes.	0 minutes (Off)
Screen lock	Enable or disable the lock in the MiTime unit. To Lock: Enter a 3 digit code for protection To Unlock: Enter the 3 digit code	000 Master Code 401
Powersave	To reduce power use when not being adjusted. Available options are: Powersave off, partial display with key data, no display until button press	Powersave off
System Reset	Will reset all settings to factory per-sets	
Signal Strength	Informs about the current signal strength in the various zones	
Service Settings	To help comply with regulation 36 of the Gas safety [Installation & Use] regulations 1998	
Si Status	Enable or disable Service mode	Disabled
Si Type	Select between, Reduced Comfort, Switched Off & No Effect (warnings only)	Reduced Comfort
Reduced comfort duration	Set the duration for the reduced comfort setting (0 to 60mins.)	15 min.
Si due date	Set the date the next boiler service is due	Today
Warning start	Set the number of days for the on-screen service due warning (0 to 60 days)	30 days
Boost status	Enable or disable Service Boost	Disabled
No. of boosts	Set the number of Boosts to be available after service is due (1 to 99)	10
Audible Alarm	Enable or disable Service Alarm	Enabled
Installer tel	Enter the Installer telephone number if required	
Set password	Set password to restrict access to the Service settings	0000

Note: if you need to bind a MiStat thermostat, enter the MiStat menu as described in Step 4 until 11 WIRELESS is shown, press +/- to show 12 BIND, press (D) to select. You also need to enter the binding process on the MiTime unit, by entering the installer menu, then the zone setting and RF binding menu options as shown in the table above.

MiTime T710R, T720R, T740R, T720M, T740M	
Voltage	MiTime: 230V a.c. MiStat: 2 x AA, 1.5V alkaline batteries
Switch Rating	MiTime: 2 (1) A 230V a.c. each switch
Ambient temp	Operating: 0° to 45°C (MiTime 3/4 channel 0° to 40°C, MiStat C 0° to 50°C) Storage: -20°C to 55°C
Without mains power	MiTime Display: blank MiTime Time: always kept MiTime Programme times: always preserved
Programming resolution	MiTime: 1 minute
Pollution degree	MiTime: 2
Rated impulse voltage	MiTime: 2.5kV
Ball pressure test temperature	MiTime: 75°C
Radio frequency	868.3 MHz (Bi-directional communication)
Radio signal range	30m typically. The range may be affected by the composition / density and number of walls between the MiTime and MiStat
Temperature range	MiStat Room: 5°C to 30°C MiStat Cylinder: 40°C to 70°C
Control accuracy	MiStat Room: <0.6°C at 4°/hour MiStat Cylinder: +0/-8°C
Wiring	MiTime: Fixed wiring only, to comply with current IEE regulations (BS7671) MiStat Room: No wiring required MiStat Cylinder: Ø0.5mm ² 2 core cable between Sensor & MiStat
Mounting	MiTime: Industry standard wallplate MiStat: Wall bracket or table stand MiStat Sensor: Direct mounting onto cylinder
Relevant EC Directives:	2006/95/EC Low Voltage Directive 2004/108/EC Electromagnetic Compatibility Directive 1995/5/EC R&TTE Directive 2006/66/EC Battery Directive 2011/65/EU RoHS Directive
Applied Standards:	EN60730-1; EN60730-2-7; EN60730-2-9 ETSI EN 300 220-3; ETSI EN 301 489-3