

# Grant VORTEX Pro External Combi

Combi 21e, Combi 26e and Combi 36e Condensing Oil Boiler Range

## Installation & Servicing Instructions



# Commissioning Report

## For use with Kerosene\* only.

### After installing the boiler leave these instructions with the User.

This appliance is deemed a controlled service and specific regional statutory requirements may be applicable.

### \*Operation on Bio-fuel

All Grant Vortex Pro condensing boilers, manufactured since May 2011, are suitable for operation on both standard kerosene (Class C2 to BS2869) and also bio-kerosene – up to a 30% blend (B30K).

All burner settings and nozzle sizes (as detailed in Section 2.3 of this manual) are correct for both standard kerosene and bio-kerosene (B30K).

In order to operate this boiler on bio-kerosene it will be necessary to take the following actions:

- Use a bio-kerosene (B30K) compatible flexible oil line in place of the oil line supplied with this boiler.
- Have your oil storage tank and oil supply line (including all pipework, sight gauges, filters, isolating valves, fire valves, de-aeration devices, etc.) checked for their compatibility with bio-kerosene (B30K).

Where necessary some, or all, of these items may have to be replaced with a bio-kerosene compatible alternative.

- Check the suitability of the flue system with Grant UK.
- Use only bio-kerosene (B30K) that conforms to OPS24.

### IMPORTANT

Under no circumstances should the boiler be used with bio-kerosene without the above actions being taken first.

Date: \_\_\_\_\_

Commissioning engineer: \_\_\_\_\_

Tel. No: \_\_\_\_\_

Boiler model: \_\_\_\_\_ Boiler output: \_\_\_\_\_ kW

Fuel type: Kerosene

Nozzle size: \_\_\_\_\_ Pump pressure: \_\_\_\_\_

Air setting: \_\_\_\_\_ Flue gas % CO<sub>2</sub>: \_\_\_\_\_

Net flue gas temp: \_\_\_\_\_ Smoke No: \_\_\_\_\_

System flushed: Yes / No

Corrosion inhibitor added: Yes / No

Antifreeze added: Yes / No

(where there is a Yes / No - please circle appropriate answer)

### For sealed systems only:

Expansion vessel size : \_\_\_\_\_ litres

Expansion vessel change pressure : \_\_\_\_\_ bar

Sealed system fill pressure (cold) : \_\_\_\_\_ bar

### Service Log

It is recommended that the boiler should be regularly serviced, at least once a year, and the details entered in the Boiler Handbook by the service engineer.



## GRANT ENGINEERING (UK) LIMITED

Hopton House, Hopton Industrial Estate, Devizes, Wiltshire SN10 2EU

Tel: 01380 736920 Fax: 01380 736991

Email: sales@grantuk.com www.grantuk.com

This manual is accurate at the date of printing but will be superseded and should be disregarded if specifications and/or appearances are changed in the interests of continued product improvement.  
All goods sold are subject to our official Conditions of Sale, a copy of which may be obtained on application.  
© Grant Engineering (UK) Limited 2012. No part of this manual may be reproduced by any means without prior written consent.

# Contents

<b>1</b>	<b>Introduction</b>	<b>4</b>	<b>8</b>	<b>Electrical</b>	<b>20</b>
1.1	How a Condensing Boiler Works	4	8.1	Connecting the Power Supply	20
1.2	Boiler Description	4	8.2	Connecting the Controls - Heating Only	22
<b>2</b>	<b>Technical Data</b>	<b>6</b>	8.3	Connecting the Controls - Heating and Hot Water	23
2.1	Boiler Technical Data	6	8.4	Connecting a Remote Frost Thermostat	25
2.2	Approximate Air Damper Setting	7	<b>9</b>	<b>Flue System &amp; Air Supply</b>	<b>26</b>
2.3	Vortex Pro Combi e Oil Boilers using Class C2 Kerosene	7	9.1	Low Level Discharge Flue	26
2.4	Flue Gas Analysis	7	9.2	Grant Green System	27
2.5	Boiler Dimensions	7	9.3	Grant Hybrid System	27
<b>3</b>	<b>Oil Storage &amp; Supply System</b>	<b>8</b>	9.4	Grant Horizontal System	28
3.1	Fuel Supply	8	9.5	General Guidance	28
3.2	Burner Oil Connection	11	9.6	Air Supply	28
<b>4</b>	<b>Boiler Installation Information</b>	<b>12</b>	<b>10</b>	<b>Commissioning</b>	<b>30</b>
4.1	Introduction	12	10.1	Before Switching On	30
4.2	Boiler Location	12	10.2	Switching On	30
4.3	Preparation for Installation	12	10.3	Running the Boiler	31
4.4	Installing the Boiler	12	10.4	Balancing the System	31
4.5	Expansion Vessel	13	10.5	Completion	31
4.6	Filling and Venting the System	13	10.6	Air Adjuster Disc - Combi 21 only	32
4.7	Regulations Compliance Requirements	13	10.7	Information for the User	32
4.8	Completion	14	<b>11</b>	<b>Boiler Servicing</b>	<b>33</b>
4.9	Before you Commission	14	11.1	Checking before Servicing	33
4.10	Underfloor Heating Systems	14	11.2	Dismantling Prior to Servicing	33
4.11	Pipework Materials	14	11.3	Cleaning the Boiler	33
4.12	Sealed Systems	14	11.4	Cleaning the Burner	35
4.13	Underfloor Pipework	14	<b>12</b>	<b>Fault Finding</b>	<b>36</b>
<b>5</b>	<b>Pipe Connections</b>	<b>15</b>	12.1	Initial Checklist - for Installer or Service Engineers	36
5.1	Water Connections	15	12.2	Main Fault Finding Procedure	37
5.2	Making the Water Connections	15	12.3	Poor Hot Water Checklist	40
5.3	Domestic Hot Water System	16	12.4	Riello RDB Burner Fault Finding	41
5.4	To use the Water Hardness Kit	16	<b>13</b>	<b>Spare Parts</b>	<b>42</b>
<b>6</b>	<b>Condensate Disposal</b>	<b>17</b>	<b>14</b>	<b>Health &amp; Safety Information</b>	<b>44</b>
6.1	General Requirements	17	14.1	Insulation Materials	44
6.2	Connections	17	14.2	Insulation Materials	44
6.3	Pipework	17	14.3	Kerosene and Gas Oil Fuels (mineral oils)	44
6.4	External Pipework	17	<b>15</b>	<b>EC Declaration of Conformity</b>	<b>45</b>
6.5	Condensate Soakaway	17	<b>16</b>	<b>Warranty</b>	<b>46</b>
6.6	Condensate Trap	18	16.1	The Vortex Oil Boiler Warranty	46
6.7	Condensate Disposal Pipework	18	16.2	Extended Warranty	47
6.8	Inspection and Cleaning of Trap	18			
<b>7</b>	<b>Sealed Systems</b>	<b>19</b>			
7.1	System Models	19			

# 1 Introduction

This manual is intended to guide engineers in the installation and maintenance of Grant VORTEX Pro External Combi e boilers. A separate manual is available to guide users in the operation of these boilers, and is printed inverted at the end of this manual.

The following special text formats are used in this manual for the purposes listed below:

## WARNING

Warning of possible human injury as a consequence of not following the instructions in the warning.

## CAUTION

Caution concerning likely damage to equipment or tools as a consequence of not following the instructions in the caution.

## NOTE

Note text. Used for emphasis or information not directly concerned with the surrounding text but of importance to the reader.

### 1.1 How a Condensing Boiler Works

During the combustion process, hydrogen and oxygen combine to produce heat and water vapour. The water vapour produced is in the form of superheated steam in the heat exchanger. This superheated steam contains sensible heat (available heat) and latent heat (heat locked up in the flue gas). A conventional boiler cannot recover any of the latent heat and this energy is lost to the atmosphere through the flue.

The Grant VORTEX Pro Combi e condensing boilers contain an extra heat exchanger which is designed to recover the latent heat normally lost by a conventional boiler. It does this by cooling the flue gases to below 90° C, thus extracting more sensible heat and some of the latent heat. This is achieved by cooling the flue gases to their dew point (approximately 55° C).

To ensure maximum efficiency, the boiler return temperature should be 55° C or less, this will enable the latent heat to be condensed out of the flue gases.

The boiler will achieve net thermal efficiencies of 100%.

To achieve maximum performance from the Grant VORTEX Pro Combi e boilers, it is recommended that the heating system is designed so that a temperature differential of 20°C between the flow and return is maintained.

The Grant Vortex Pro Combi e boilers will however still operate at extremely high efficiencies even when it is not in condensing mode and therefore is suitable for fitting to an existing heating system without alteration to the radiator sizes. The boiler is capable of a maximum flow temperature of 78° C.

### 1.2 Boiler Description

The Vortex Pro Combi e boilers are automatic pressure jet oil boilers designed for use with a sealed central heating system and will provide domestic hot water at mains pressure.

All boilers are supplied with the control panel and the burner factory fitted, and a factory fitted low level discharge fuel system.



## NOTE

For conventional flue applications, where required, Grant recommends the use of the Grant 'Green' flue system, to provide an insulated twin-wall flue system. Refer to Section 9 for further details.

**Only Kerosene must be used with a low level discharge flue appliance. The Vortex Pro Combi e boilers are only suitable for use with Kerosene.**

All burners are ready to connect to a single pipe system with a loose flexible fuel line (900mm) and <sup>3</sup>/<sub>8</sub>" to <sup>1</sup>/<sub>4</sub>" BSP male adaptor supplied with the boiler. If required, an additional flexible fuel line (900mm) and <sup>3</sup>/<sub>8</sub>" to <sup>1</sup>/<sub>4</sub>" BSP male adaptor are available to purchase from Grant Engineering (UK) Limited, for two-pipe oil supply system, Part No. RBS36.

The temperature of the water leaving the boiler to heat the radiators is User adjustable.

The setting of the boiler thermostat on the Vortex Pro Combi e boilers has no effect on the hot water performance.

Figure 1-1 shows the components in the Vortex Pro Combi e boilers and the position of the control panel. Figure 1-2 shows the details of the control panel.

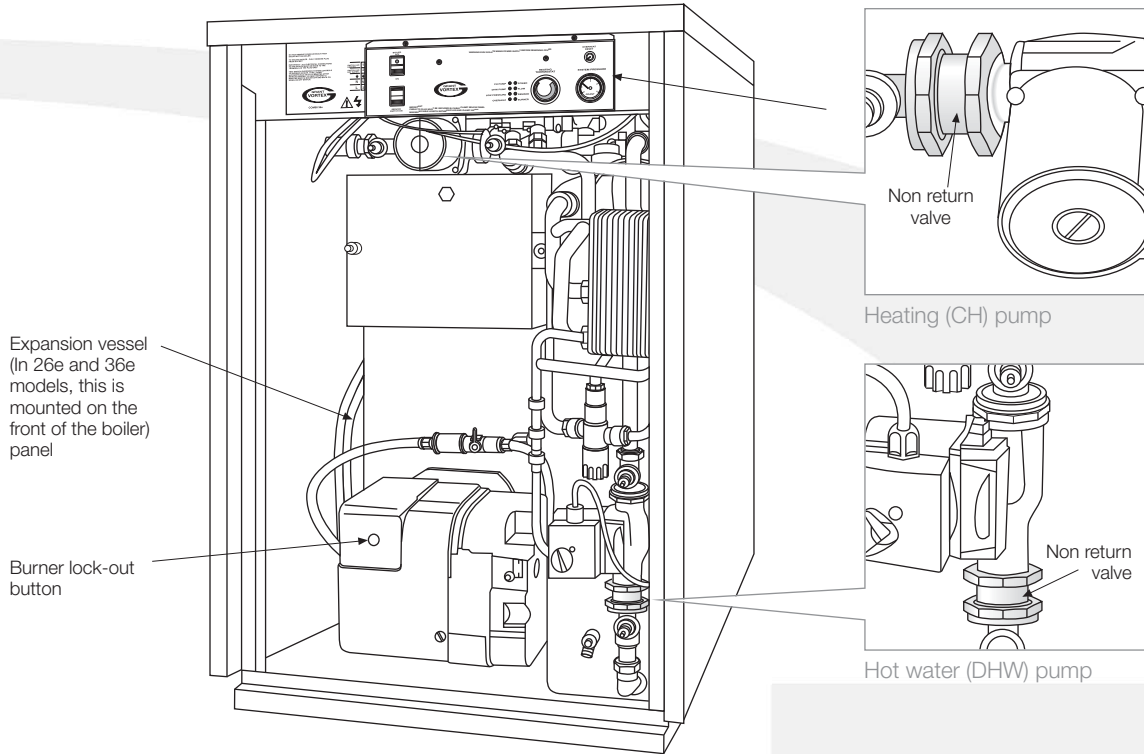

Figure 1-1: Vortex Pro Combi 21e boiler with front panel removed showing position of control panel

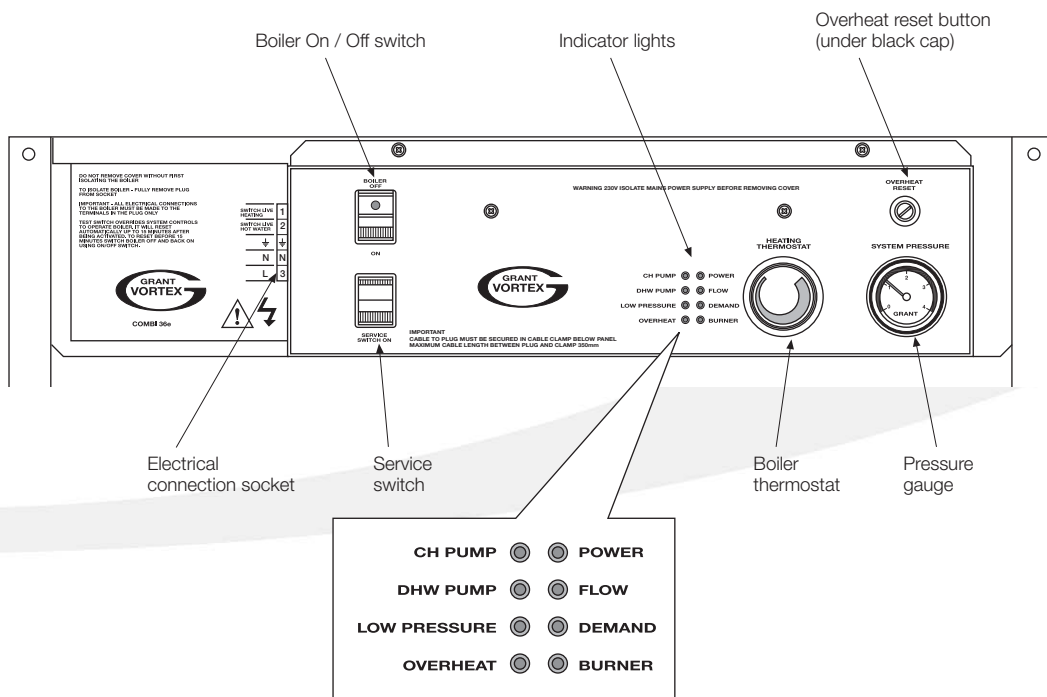

Figure 1-2: Vortex Pro Combi e boiler control panel

# 2 Technical Data

## 2.1 Boiler Technical Data

Model		Vortex Pro Combi 21e	Vortex Pro Combi 26e	Vortex Pro Combi 36e
Boiler water content (including 32 litre primary store)	Litres	48.0	48.5	53.5
	Gal	10.6	10.7	11.8
Weight (dry)*	kg	147	188	218
	lbs	325	415	481
Connections: Heating flow and return	mm	22	22	28
Cold water mains inlet	mm	15	15	22
Domestic hot water outlet	mm	15	15	22
Pressure relief valve discharge	mm	15		
Condensate connection		22mm plastic pipe		
Flue size (conventional)***		100mm (4 in) diameter		
Waterside resistance Flow/Return temp. diff. of 10°C	mbar	28.5		26.0
Waterside resistance Flow/Return temp. diff. of 20°C	mbar	10.0		9.5
Boiler thermostat range	°C	65 to 78		
Limit (safety) thermostat switch off temp.	°C	111°C +0 -3		
Maximum heating system pressure (cold)	bar	1.0		
Minimum heating system pressure (cold)	bar	0.5		
Pressure relief valve	bar	2.5		
Expansion vessel (pre-charged at 1 bar)	litres	10	12	14
Maximum heating system volume**	litres	106	128	148
Maximum operating pressure	bar	2.5		
Minimum domestic hot water flow rate		3.0 litres / min (0.66 gal/min)		
Maximum domestic hot water temperature	°C	65 (factory set)		
Maximum mains water inlet pressure	bar	8.0		
Minimum recommended mains water inlet pressure	bar	2.5		
Maximum hearth temperature	°C	Less than 50		
Electricity supply		230V / 240V ~ 50Hz Fused at 5 Amp		
Motor power		90 W max.		
Starting current	Amp	4.2	2.6	
Running current	Amp	0.85		
Oil connection		1/4" Male BSP (on end of flexible fuel line)		
Conventional flue***		Minimum flue draught - 8.7 N/m <sup>2</sup> (0.035 in wg) Maximum flue draught - 37 N/m <sup>2</sup> (0.15 in wg)		

\* Weight includes burner but excludes flue

\*\* Based on expansion vessel charge and initial cold system pressure of 0.5 bar

\*\*\* If used as alternative to low level terminal supplied with boiler (see section 9)

## 2.2 Approximate Air Damper Setting

### ! NOTE

Burners are supplied factory set at the outputs shown.

When commissioning, the air damper must be adjusted to obtain the correct CO<sub>2</sub> level and the Installer must amend the data label.

## 2.3 Vortex Pro Combi Oil Boilers using Class C2 Kerosene

### ! NOTE

Vortex Combi e boilers are only for use with kerosene.

The data given above is approximate only and is based on the boiler being used with a low level discharge flue.

The above settings may have to be adjusted on site for the correct operation of the burner.

Gas Oil is not suitable for use with a Grant Vortex Pro Combi e boiler.

The net flue gas temperatures given above are  $\pm 10\%$ .

When commissioning the air damper must be adjusted to obtain the correct CO<sub>2</sub> level.

## 2.4 Flue Gas Analysis

To allow the boiler to be commissioned and serviced, the boiler is supplied with a combustion test point on the front cleaning door. When this test point is used please note the following:

- The test point is for CO<sub>2</sub> and smoke readings only.
- The boiler efficiency and temperature must be taken from the flue.
- Final combustion readings must be taken from the flue terminal (or test point on flue elbow if Green system is used) with all panels fitted.

Model	Burner type	Heat output		SEDBUK SAP 2009	Nozzle	Oil pressure	Smoke number	Burner head	Fuel flow	Flue gas temp	CO <sub>2</sub>
		kW	Btu/h	%		bar			kg/h	°C	%
21e	Riello RDB 2.2	21.0	71,650	89.5	0.60/80°EH	9.0	0-1	T1	1.83	80 (flue) 235 (door)	12
26e	Riello RDB 1	26.0	88,700	90.2	0.75/80°EH	8.0	0-1	T2	2.16	75 - 80	12
36e	Riello RDB 2.2	36.0	123,000	91.6	1.00/80°EH	9.1	0-1	T5	3.01	78	12

## 2.5 Boiler Dimensions

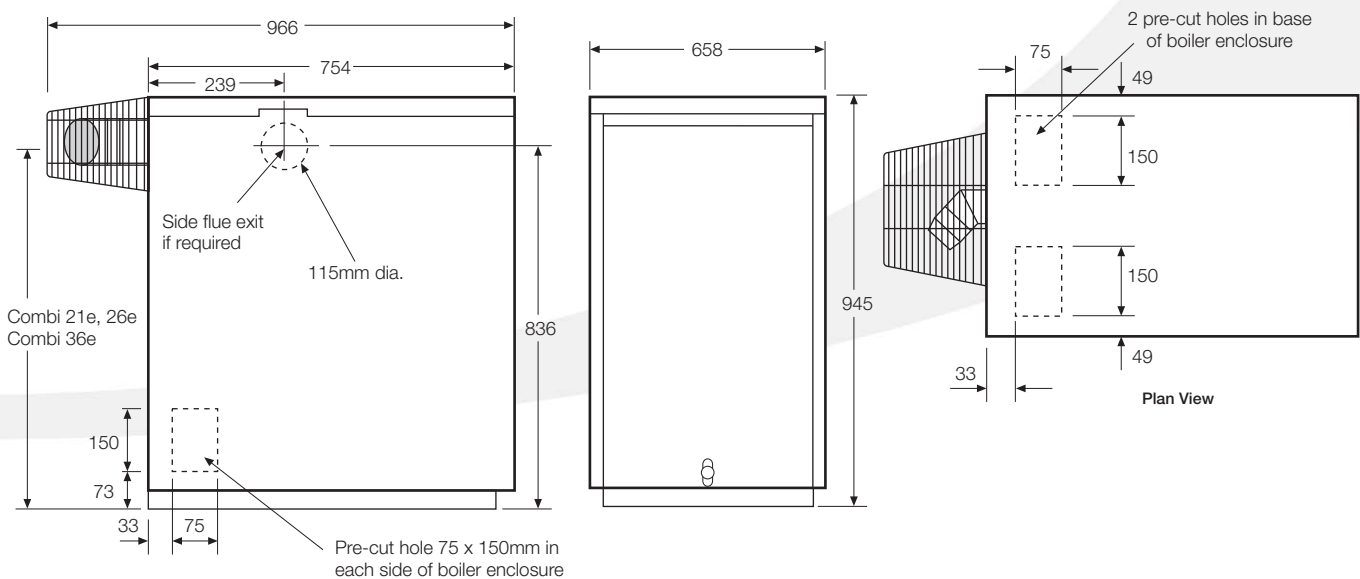

Figure 2-1: Vortex Pro External Combi e dimensions

All dimensions in the diagram above are in millimetres.

# 3 Oil Storage & Supply System

## 3.1 Fuel Supply

### Fuel Storage

The tank should be positioned in accordance with the recommendations given in BS 5410:1:1997, which gives details of filling, maintenance and protection from fire.

A steel tank may be used and must be constructed to BS 799:5:1987 and OFS T200.



A galvanised tank must NOT be used.

A plastic tank may be used and must comply with OFS T100.



Plastic tanks should be adequately and uniformly supported on a smooth level surface, across their entire load bearing base area, that is, the area in contact with the ground.

### Fuel Pipes

Fuel supply pipes should be of copper tubing with an external diameter of at least 10mm.

Galvanised pipe must not be used.

All pipe connections should preferably use flared fittings. Soldered connections **must not** be used on oil pipes.



**Flexible pipes must not be used outside the boiler case.**

A remote sensing fire valve must be installed in the fuel supply line at least one metre before it enters the boiler casing, with the sensing head located above the burner.



Grant UK recommend that a fire valve with a temperature rating of 95°C be installed on any Grant Vortex Pro Combi.

Recommendations are given in BS 5410:1:1997.

A metal bowl type filter with a replaceable micronic filter must be fitted in the fuel supply line adjacent to the boiler. A shut-off valve should be fitted before the filter, to allow the filter to be serviced.

A flexible fuel line, adaptor and 1/4" BSP isolation valve is supplied loose with the boiler for the final connection to the burner. If a two pipe system or Tiger Loop system is used, an additional flexible fuel line (900mm) and 3/8" to 1/4" BSP male adaptor are available from Grant Engineering (UK) Limited (Part No. RBS36).

Metal braided flexible hoses should be replaced annually when the boiler is serviced. Long life flexible hoses should be inspected annually and replaced at least every 60 months.

### Single Pipe System

Where the storage tank outlet is above the burner the single pipe system should be used. The height of the tank above the burner limits the length of pipe run from the tank to the burner.

As supplied the burner is suitable for a single pipe system.

Head A (m)	Max Pipe Run (m)	
	10mm OD Pipe	12mm OD Pipe
0.5	10	20
1.0	20	40
1.5	40	80
2.0	60	100

### Two Pipe System

With the storage tank outlet below the burner, a two pipe system should be used. The pipe runs should be as shown in Figure 3-2. The return pipe should be at the same level in the tank as the supply pipe, both being 75 to 100mm above the base of the tank. The pipe ends should be a sufficient distance apart so as to prevent any sediment disturbed by the return entering the supply pipe.

Avoid the bottom of the tank being more than 3.5m below the burner.

A non-return valve should be fitted in the supply pipe together with the filter and fire valve. A non-return valve should be fitted in the return pipe if the top of the tank is above the burner.

The pump vacuum should not exceed 0.4 bar. Beyond this limit gas is released from the oil.

**For guidance on installation of top outlet fuel tanks and suction oil supply sizing, see OFTEC technical book 3.**

Available at [www.oftec.org.uk](http://www.oftec.org.uk)

Head A (m)	Max Pipe Run (m)	
	10mm OD Pipe	12mm OD Pipe
0	35	100
0.5	30	100
1.0	25	100
1.5	20	90
2.0	15	70
3.0	8	30
3.5	6	20



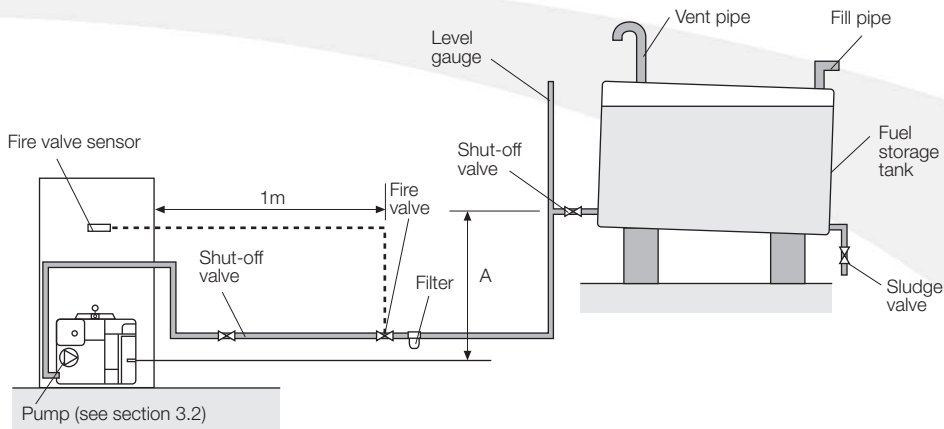

Figure 3-1: Single pipe system

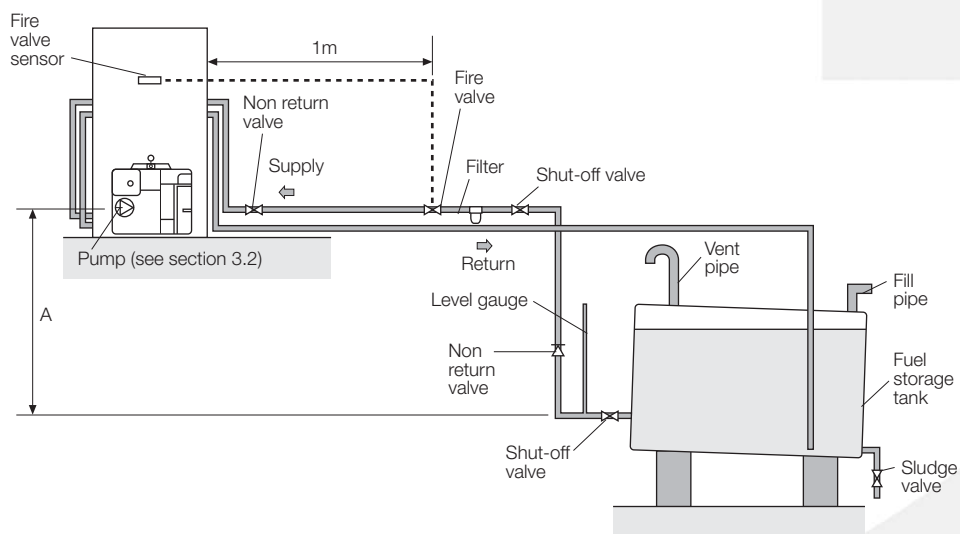

Figure 3-2: Two pipe system

# 3 Oil Storage & Supply System

## Tiger Loop System

When The storage tank is below the burner, an alternative to a two pipe system can be achieved using a 'Tiger Loop' type oil de-aerator. This effectively removes the air from the oil supply on a single pipe lift.

The de-aerator is connected close to the boiler as a two pipe system (omitting the non-return valve) as shown in Fig. 3-3. Refer to the manufacturer's instructions supplied with the de-aerator. The de-aerator must be mounted vertically, as shown in Figures 3-3 and 3-4.

To be used with a Tiger Loop system, the burner must be fitted with an additional flexible fuel line (a flexible fuel line (900mm) and 3/8" to 1/4" BSP male adaptor are available to purchase from Grant Engineering (UK) Limited - Part No. RBS36).



## WARNING

To prevent any possibility of fuel fumes entering the boiler, the de-aerator must be fitted outside the casing.



Figure 3-4: Tiger loop de-aeration device

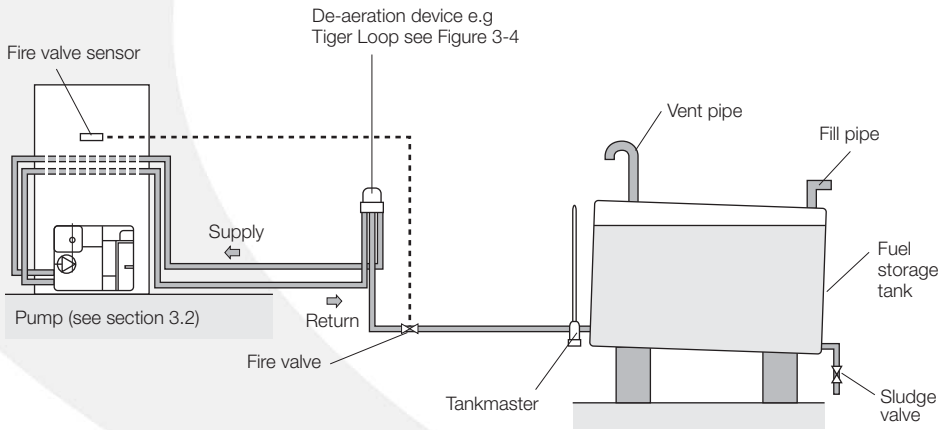

Figure 3-3: De-aeration device system

### 3.2 Burner Oil Connection

The fuel pump is supplied for use with a single pipe fuel supply system. For use on a two pipe system, it is necessary to fit the By-pass screw into the tapping in the return port. See Figure 3-5.

The By-pass screw is supplied in the boiler accessory pack.

The procedure is as follows:

1. Remove the plastic burner cover (two screws).
2. Remove and discard the blanking plug from the return connection of the pump and fit the By-pass screw using a hexagonal key.
3. Connect the return oil flexible fuel line to the pump.
4. Connect the  $\frac{3}{8}$ " to  $\frac{1}{4}$ " BSP adaptor to the flexible fuel line.

Flexible fuel lines and adaptors are available to purchase from Grant Engineering (UK) Ltd.

The burner cover may be left off until the boiler is commissioned.

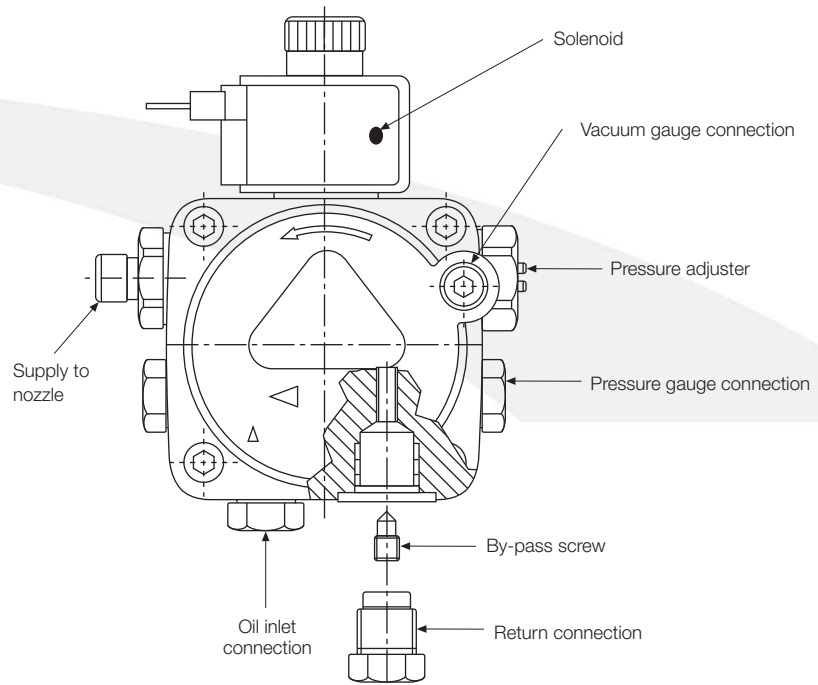

Figure 3-5: Burner pump connections

## WARNING

The blanking plug supplied in the inlet (suction) port may now be plastic and will not provide an oil tight seal when the pump is running.

Ensure the supply from the tank is connected to this port and the plastic plug is discarded.

# 4 Boiler Installation Information

## 4.1 Introduction

The boiler is supplied already fully assembled with the flue terminal guard supplied loose inside the boiler.

## 4.2 Boiler Location

1. The External Combi boiler must stand on a solid, level surface capable of supporting the weight of the boiler when full of water, e.g. a prepared concrete standing, paving slabs bedded down on sand / cement, or similar.
2. The Module can be installed either against the building or 'free standing' some distance away from the building.
3. The Module must be positioned such that the required clearances from the low level flue outlet, as shown in Figure 9-1, are achieved.
4. Adequate clearance must be left around the boiler for servicing. In particular, a minimum clearance of 600mm above the boiler for removal of the top panel and 600mm at each end allow for access to the burner and condensate trap.

## 4.3 Preparation for Installation

1. Carefully remove the packaging from the boiler and remove it from the transit pallet.
2. Remove the case top panel and also the front and rear panels, as required.
3. The flue may exit the boiler from the left, right or rear of the casing. Carefully press out the pre-cut section on the side or end casing panel to provide the opening in the required position for the flue to pass through the casing.  
Fit the cover panel (with the round flue exit hole) over the square flue opening in the casing. Fit the circular rubber sealing grommet provided into the hole in the cover panel before fitting the flue terminal section.
4. Slacken the wing nuts holding the flue elbow and rotate the elbow to the required direction for the flue to exit the casing.
5. Push the end of the flue terminal section with the red seal through the seal in the casing. The terminal has been factory lubricated. Take care not to dislodge or damage the red seals.

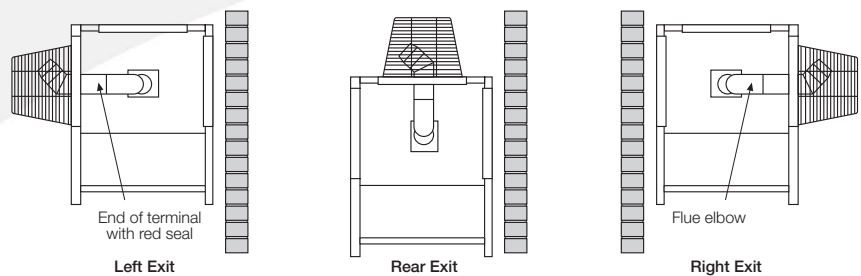
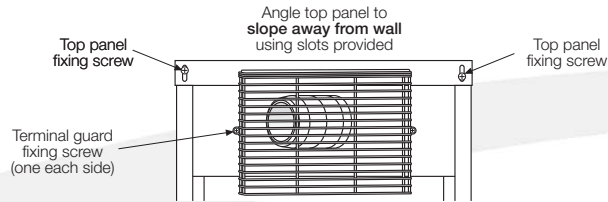

Figure 4-1: Standard supplied flue

6. Carefully insert the terminal into the flue elbow until the bend of the terminal contacts the outer casing, then, pull the terminal forward approximately 25mm and rotate the bend so that the outlet is horizontal.

Rear Exit - The flue must discharge away from the building.

Side Exit - The flue should discharge towards the rear of the casing to prevent flue gases reentering the boiler casing through the air inlet vents on the casing front door.

The flue terminal must be fitted horizontally to prevent dripping from the end of the terminal.

7. Tighten the wing nuts holding the flue elbow and fit the stainless steel flue guard using the two screws provided.
8. The top panel of the casing has been designed so that it may be fitted to create a slight slope away from the side positioned against the wall. To tilt the top panel, loosen the four top panel casing screws, one at each corner and push down on the side furthest from the wall. Tighten the screws. See Figure 4-1.

## 4.4 Installing the Boiler

1. If the boiler is to be fitted against the wall, prepare the wall to accept the heating system pipework. To mark the wall for drilling, refer to Figure 2-1 for the positions of the pipework openings in the enclosure sides.

## ! NOTE

Pipework should be insulated where it passes through the wall into the boiler enclosure.

2. A painted steel wall flashing strip is supplied with the boiler to cover the gap between the wall and the boiler casing. It should be secured to the wall leaving a gap of 30mm between the bottom edge and the top of the casing top panel, to allow removal of the top panel for servicing.
3. If the boiler is to be installed 'free standing' (that is, away from a wall) and the pipework run underground, push out the 'knock-outs' to open the required pipe openings in the base of the boiler enclosure.  
Using a sharp knife, cut through the polystyrene in the base, around the edge of the holes, to allow the flow and return pipes to enter the enclosure.

## ! NOTE

A spare blanking plate with a 112mm diameter hole is supplied with the Outdoor Vortex Combi boilers. This is intended to provide an opening into the boiler if a 110mm soil pipe is used as a pipe duct through the wall.

4. The electrical supply to the boiler should be routed through the wall in a suitable conduit, such that it enters the boiler enclosure via one of the unused pipework openings. The cable can be routed to the front of the boiler, for connection to the boiler control panel, either over the top or beneath the boiler heat exchanger. Heat resistant PVC cable, of at least 1.0mm<sup>2</sup> cross section should be used within the boiler enclosure. See section 8.1 for details.
5. The oil supply line should be installed up to the position of the boiler. Refer to Section 3 for details. The final connection into the boiler enclosure can be made with 10mm soft copper, routed along the base of the enclosure (either between the enclosure and wall or in front of the enclosure) to enter through one of the holes located in the bottom edge side panel, at the front (burner) end. See Section 3 for details.

#### 4.5 Expansion Vessel

The expansion vessel fitted is supplied with a charge pressure of 1.0 bar (equivalent to a max. static head of 10.2 metres). The charge pressure must not be less than the actual static head at the point of connection. Do not pressurise the vessel above 1.5 bar.



### NOTE

#### The air pressure in the vessel must be checked annually.

The central heating system volume, using the expansion vessel as supplied, must not exceed the recommended volumes. If the system volume is greater, an extra expansion vessel (complying with BS4841) must be fitted as close as possible to the central heating return connection on the boiler. The charge pressure of the extra vessel must be the same as the vessel fitted in the boiler. Refer to BS7074:1 for further guidance.

The air charge pressure may be checked using a tyre pressure gauge on the expansion vessel Schraeder valve. The vessel may be re-pressurised using a suitable pump. When checking the air pressure the water in the heating system must be cold and the system pressure reduced to zero.

#### 4.6 Filling and Venting the System

##### Automatic and manual air vents

The boiler is fitted with two Automatic air vents at the top of the boiler, located as follows:

- one on the top of the primary store
- one on the heating flow pipe

Refer to Figure 5-1.

Check that the small black plug on the side of each air vent is screwed in fully. Then unscrew it one complete turn - the cap remains in this position thereafter.

A single manual air vent is also fitted at the top of the boiler - on the return pipe. Unscrew the cap one turn vent air from the pipe during filling and then fully close the cap.

##### Filling loop

If the flexible filling loop is used to fill the system, ensure it is connected and that the valve connecting it to the boiler is open and the valve at the front is closed.

A valve is open when the operating lever is in line with the valve, and closed when it is at right angles to it.

Ensure that the mains cold water supply valve is open (operating lever in line with the valve), then turn on the mains cold water supply and gradually open the front valve on the filling loop until water is heard to flow.

Vent each radiator in turn, starting with the lowest one in the system, to remove air.

It is important the circulating pumps are properly vented to avoid them running dry and the bearings being damaged.

Unscrew and remove the plug from the centre of the pump. Using a suitable screwdriver rotate the exposed spindle about one turn. When water starts to trickle out, replace the plug.

The Hot water pump must also be vented as described above.

Check the operation of the safety valve by turning the head anticlockwise until it clicks. The click is the safety valve head lifting off its seat allowing water to escape from the system. Check that this is actually happening.

Continue to fill the system until the pressure gauge indicates between 0.5 and 1.0 bar. Close the fill point valve and check the system for water soundness, rectifying where necessary. Water may be released from the system by manually operating the safety valve until the system design pressure is obtained.

The system design pressure (cold) should be between 0.5 bar and 1.0 bar. The pressure is equivalent to the maximum static head in bar + 0.3 (1 bar = 10.2 metres of water), where the static head is the vertical height from the centre of the expansion vessel to the highest point of the system.

Close the valves either side of the filling loop and disconnect the loop.

#### 4.7 Regulatory Compliance Requirements

Installation of a Grant VORTEX Pro External Combi e must be in accordance with the following recommendations:-

- Building Regulations for England and Wales, and the Building Standards for Scotland issued by the Department of the Environment and any local Byelaws which you must check with the local authority for the area.
- Model and local Water Undertaking Byelaws.
- Applicable Control of Pollution Regulations.
- The following OFTEC requirements:
  - OFS T100 Polythene oil storage tanks for distillate fuels.
  - OFS T200 Fuel oil storage tanks and tank bunds for use with distillate fuels, lubrication oils and waste oils.

# 4 Boiler Installation Information

Further information may be obtained from the OFTEC Technical Book 3 (Installation requirements for oil storage tanks) and Technical Book 4 (Installation requirements for oil fired boilers).

The installation should also be in accordance with the latest edition of the following British Standard Codes of Practice:

- BS 715 Metal flue pipes, fittings, terminals and accessories.
- BS 799:5 Oil storage tanks.
- BS 1181 Clay flue linings and flue terminals.
- BS 4543:3 Factory made insulated chimneys for oil fired appliances.
- BS 4876 Performance requirements for oil burning appliances.
- BS 5410:1 Code of Practice for oil firing appliances.
- BS 5449 Forced circulation hot water systems.
- BS 7593 Code of Practice for treatment of water in heating systems.
- BS 7671 Requirements for electrical installations, IEE Wiring Regulations.



## NOTE

**Failure to install and commission appliances correctly may invalidate the boiler warranty.**



## WARNING

**Before starting any work on the boiler, or fuel supply please read the health and safety information given in Section 14.**

### 4.8 Completion

Please ensure that the OFTEC CD/10 installation completion report (provided with the boiler) is completed in full.

Leave the top copy with the User.

Retain the carbon copy.

Ensure that the User Information pack (supplied with the boiler) is handed over to the Householder.

### 4.9 Before you Commission

To avoid the danger of dirt and foreign matter entering the boiler the complete heating system should be thoroughly flushed out - before the boiler is connected and then again after the system has been heated and is still hot. This is especially important where the boiler is used on an old system.

For optimum performance after installation, this boiler and its associated central heating system must be flushed in accordance with the guidelines given in BS 7593:1992 'Treatment of water in domestic hot water central heating systems'.

This must involve the use of a proprietary cleaner, such as Betz Dearborn's Sentinel X300 or X400, or Fernox Restorer. Full instructions are supplied with the products, but for more details of Betz Dearborn's products, view the website [www.sentinel-solutions.net](http://www.sentinel-solutions.net) and for more details of Fernox products view the website [www.fernox.com](http://www.fernox.com).

For Long term protection against corrosion and scale, after flushing, it is recommended that an inhibitor such as Betz Dearborn's Sentinel X100 or Fernox MB-1 is dosed in accordance with the guidelines given in BS 7593:1992.

Failure to implement the guidelines will invalidate the warranty.

### 4.10 Underfloor Heating Systems

In underfloor systems it is essential that the return temperature **must** be maintained above 40°C to prevent internal corrosion of the boiler water jacket.

### 4.11 Pipework Materials

Grant boilers are compatible with both copper and plastic pipe. Where plastic pipe is used it **must** be of the oxygen barrier type and be of the correct class (to BS 7291:Part 1:2001) for the application concerned.



## NOTE

**The first metre of pipework connected to both the heating flow and return connections of the boiler must be made in copper on all types of system - sealed or open-vented.**

### 4.12 Sealed Systems

If plastic pipe is used, the installer must check with the plastic pipe manufacturer that the pipe to be used is suitable for the temperature and pressures concerned.

Plastic pipe must be Class S to BS 7291: Part 1:2001.



## WARNING

**The boiler incorporates a low-pressure switch to shut off power to the boiler if the system pressure drops below 0.2 bar.**

### 4.13 Underfloor Pipework

Plastic pipe may be used on Underfloor systems where the plastic pipe is fitted **after** the thermostatic mixing valve. Copper tube **must** be used for at least the first metre of flow and return primary pipework between the boiler and the underfloor mixing/blending valves.

# 5 Pipe Connections

## 5.1 Water Connections

The pipework can exit the boiler enclosure through the pre-cut openings provided in either side panel to pass through the wall when installed against the building. The side flue exit openings may also be used to route the pipework and cables through the casing sides and into the building. See Section 2.5.

A spare blanking plate with a 112mm diameter hole is supplied with the Vortex Pro Combi e boilers.

This is intended to provide an opening into the boiler if a 110mm soil pipe is used as a pipe duct through the wall.

Alternatively for free standing installations, pipework can be routed down and through the pre-cut openings provided in the base of the enclosure, to be run underground to the building. See Section 2.5.

### Flow and return connections -

All models are supplied with a push-fit elbow connection for the heating flow and return - 22mm (Vortex Pro Combi 21e and 26e) or 28mm (Vortex Pro Combi 36e).

**Hot water connections -** All models are supplied with push-fit elbow connections for the cold water mains inlet pipe and hot water outlet pipe. These are 15mm for the Vortex Pro Combi 21e and 26e, and 22mm for the Vortex Pro Combi 36e.

## CAUTION

All pipes to be fitted into the push-fit connectors provided should be cut using a pipe slicer or pipe cutter - to leave the pipe ends with a slight radius and free from any burrs or sharp edges.

Pipes to be used with these fittings should not be cut square using a hacksaw.

### All Models

A 15mm discharge pipe must be connected to the safety valve outlet connection. The pipework between the safety valve and the boiler must be unrestricted, that is, no valves. The discharge pipe should be run to the outside of the boiler casing, through one of the openings provided at the base of each side panel, and terminate so that it cannot cause injury to persons or property.

A drain tap is provided at the bottom on the front of the boiler (and also on the hot water store on the Vortex Pro Combi).

## 5.2. Making the Water Connections

Flow and return pipework can be routed to either side of the boiler, whichever is adjacent to the building, from the push-fit elbows (supplied) on the flow and return connection. Refer to Figure 5-1.

Holes are provided at the base of the casing side panels to allow the condensate pipe to be run through at the rear of the boiler. It will be necessary to remove the back panel from the boiler casing to fit this pipework.

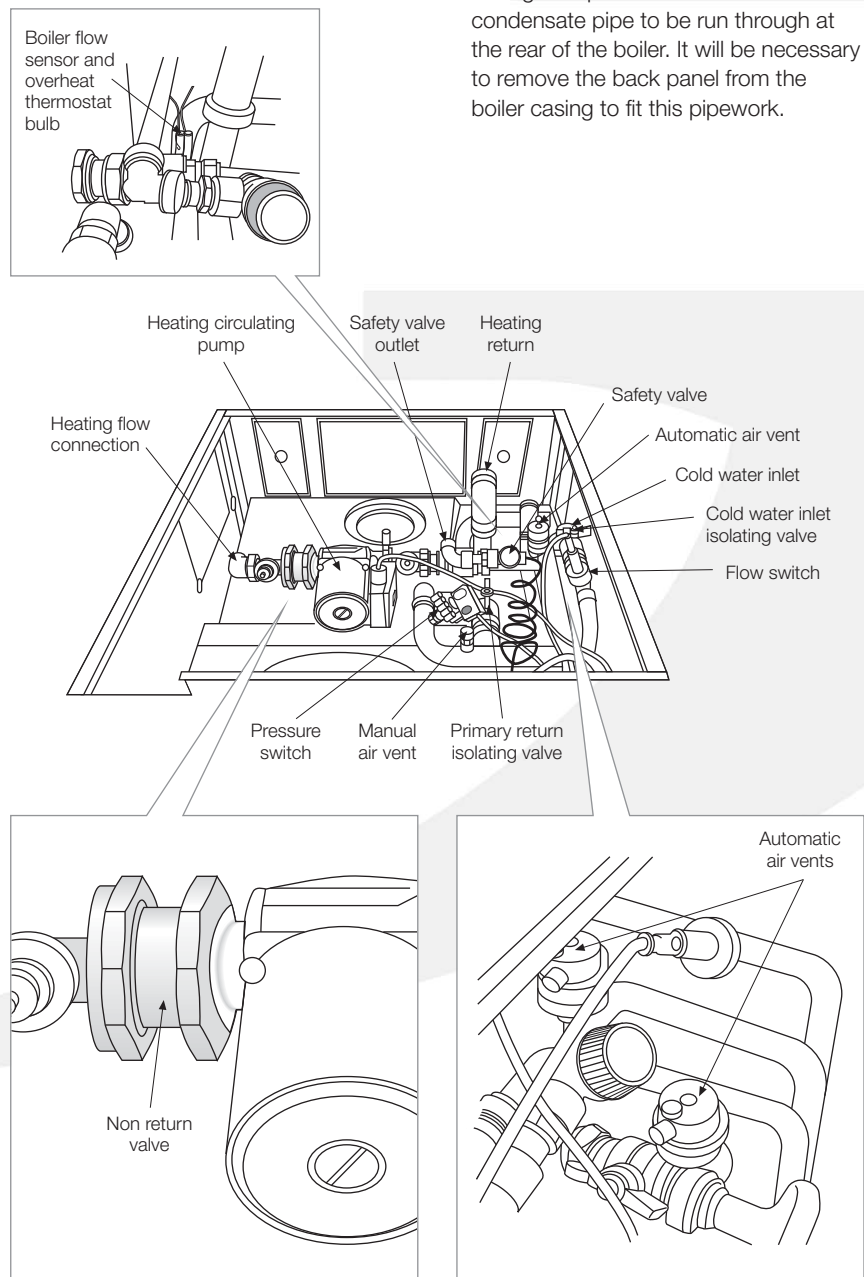

Figure 5-1: Vortex Pro Combi e pipe positions

# 5 Pipe Connections

## 5.3 Domestic Hot Water System

To maintain a longer and more consistent hot water temperature, a flow restrictor is factory fitted to all models except the Vortex Pro Combi 36e, to limit the flow rate to approximately 15 litres / minute.

The flow restrictor is located in the outlet side of the cold water inlet isolating valve.

The incoming mains water pressure should be between 1 and 8 bar to ensure efficient operation.

If the pressure is above 8 bar a pressure reducing valve must be fitted.

The boiler may still operate down to a pressure of 1.0 bar but with a reduced flow rate. The minimum flow rate needed for the flow switch to operate is 3 litres / minute.

To ensure economic use, the pipe runs between the boiler and hot taps should be as short as possible and in 15mm copper pipe or 22mm for the Vortex Pro Combi 36e only. Where possible the pipework should be insulated to reduce heat loss.

All taps and mixing valves used in the domestic hot water system must be suitable for operating at a mains pressure of up to 8 bar.

If required, a shower may be fitted in the domestic hot water system. It is recommended that thermostatically controlled shower valves are used to protect against a flow of water at too high a temperature. If a fixed head type shower is used, no anti-syphonage devices are required. If a loose or flexible head type shower is used, it must be arranged so that the head cannot fall closer than 25mm above the top of the bath, thereby preventing immersion in the bath water. If this is not practicable, an anti-syphonage device must be fitted at the point of the flexible hose connection.

The supply of hot and cold mains water direct to a bidet is allowed (subject to local Water Undertaking requirements) provided that the bidet is of the over-rim flushing type. The outlets should be shrouded and unable to have a temporary hand held spray attached. Arrangements for antisiphonage are not necessary.

Before the mains water supply pipe is connected to the boiler, it should be thoroughly flushed out to avoid the danger of dirt or foreign matter entering the boiler.

The mains water connection to the boiler must be the first connection from the mains supply.



## NOTE

**A water hardness test kit is supplied with the boiler. Should the total hardness of the water supply exceed 125 ppm, an in-line scale inhibitor should be fitted in the cold water supply to the boiler. Consult the local Water Undertaking if in doubt.**

**Do not immerse the test strip in running water and avoid contact.**

## 5.4 To use the Water Hardness Kit

Fill a clean container with a sample of water from the mains cold water supply to the boiler.

Immerse the test strip in the water for approximately one second, ensuring that all the test zones are fully wetted.

Shake off the surplus water and wait for one minute.

Assess the colouration of the test zones using the following chart.

Green Areas	Violet Areas	Hardness	Total Hardness mg/l (ppm)
4	0	Very Soft	<50 mg/l calcium Carbonate
3	1	Soft	<70 mg/l calcium Carbonate
2	2	Medium	<125 mg/l calcium Carbonate
1	3	Hard	<250 mg/l calcium Carbonate
0	4	Very Hard	<370 mg/l calcium Carbonate

*Note: (1 mg/l = 1 ppm (part per million))*

If the hardness reading is found to be in the medium to very hard range (the shaded area), it is essential that some form of water conditioner or softener is fitted to reduce scale formation within the combination boiler. Failure to do so may invalidate both the manufacturers warranty and any extended warranty covering the appliance.

The water conditioner or softener should be fitted to the cold water supply serving the appliance and in accordance with the manufacturers instructions. Grant Engineering (UK) Ltd. cannot be held responsible for any damage or misuse caused by the fitting of any water conditioning device.



## CAUTION

**Please protect the domestic hot water system from harmful effects of scale. Problems caused by the build-up of limescale are not covered under the terms of the warranty.**



# 6 Condensate Disposal

## 6.1 General Requirements

When in condensing mode the Grant Vortex PRO boilers produce condensate from the water vapour in the flue gases. This condensate is slightly acidic with a pH value of around 3 (similar to vinegar). Provision must be made for the safe and effective disposal of this condensate.

Condensate can be disposed of using one of the following methods of connection:

### Internal Connection (preferred option):

- Into an internal domestic waste system (from kitchen sink, washing machine, etc.).
- Directly into the soil stack.

### External Connection:

- Into an external soil stack
- Into an external drain or gully
- into a rainwater hopper (that is part of a combined system where sewer carries both rainwater and foul water)
- purpose made soakaway.

All condensate disposal pipes **must** be fitted with a trap - whether they are connected internally or externally to a domestic waste system/soil stack or run externally to a gully, hopper or soakaway.

## 6.2 Connections

Connections into a rainwater hopper, external drain or gully should be terminated inside the hopper / drain / gully below the grid level but above the water level.

Condensate disposal pipes should not be connected directly into rainwater downpipes or to waste / soil systems connected to septic tanks.

Condensate should not be discharged into 'grey water' systems that re-use water used in the home (not including water from toilets).

It should be noted that connection of a condensate pipe to the drain may be subject to local Building Control requirements.

## 6.3 Pipework

Condensate disposal pipework must be plastic (plastic waste or overflow pipe is suitable).

**NOTE**

Copper or steel pipe is **NOT** suitable and **MUST NOT** be used.

Condensate disposal pipes should have a minimum 'nominal' diameter of 22mm ( $\frac{3}{4}$ " ) - e.g. use 21.5mm OD polypropylene overflow pipe.

Condensate disposal pipes must be fitted with a fall (away from the boiler) of at least 2.5° (~45mm fall per metre run).

**NOTE**

Where it is not possible for the pipe to fall towards the point of discharge - either internally into a waste system or externally to a gully (e.g. for boilers installed in a basement), it will be necessary to use a condensate pump.

Condensate disposal pipes should be kept as short as possible and the number of bends kept to a minimum.

Pipes should be adequately fixed to prevent sagging, i.e. at no more than 0.5 metre intervals.

## 6.4 External Pipework

Ideally, external pipework, or pipework in unheated areas, should be avoided. If unavoidable, external pipework should be kept as short as possible (less than 3 metres) and 32mm waste pipe used to minimise the risk of ice blocking the pipe in freezing conditions.

The number of bends, fittings and joints on external pipes should be kept to a minimum to reduce the risk of trapping condensate.

**NOTE**

For a boiler installed in an unheated area such as an outhouse or garage, all condensate pipework should be considered as an 'external'.

## 6.5. Condensate Soakaway

To keep external pipework to a minimum, locate the soakaway as close as possible to the boiler but ensure it is at least 500mm from building foundations and away from other services, e.g. gas, electricity, etc.

The condensate pipe may be run above or below ground level and can enter either the top or side of the soakaway tube. Refer to Fig.6-1.

Ensure that the drainage holes in the soakaway tube face away from the building. Backfill both the soakaway tube, and the hole around it, with 10mm limestone chippings.

Only use a soakaway where the soil is porous and drains easily. Do not use in clay soils or where the soil is poorly drained.

**CAUTION**

Any damage due to condensate backing up into the boiler due to a high water table, in the case of a soakaway, or flooded drains when the condensate disposal is via a gully or soil stack, is not covered by the Grant product warranty.

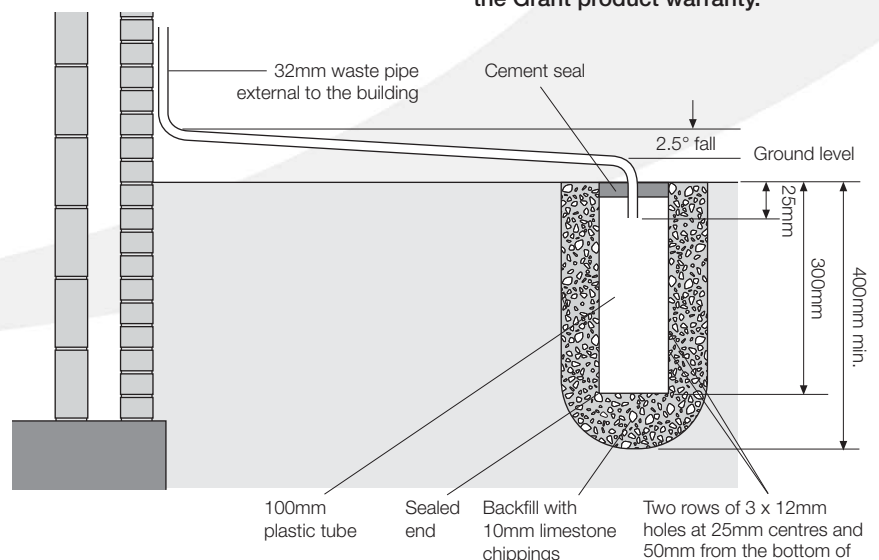

Figure 6-1: Purpose made condensate soakaway

# 6 Condensate Disposal

## 6.6 Condensate Trap

Grant Vortex PRO boilers are supplied with a factory-fitted condensate trap to provide the required 75mm water seal in the condensate discharge pipe from the boiler.

This trap incorporates a float (which will create a seal when the trap is empty) and an overflow warning outlet (fitted with a plastic sealing cap), See Figure 6-2.

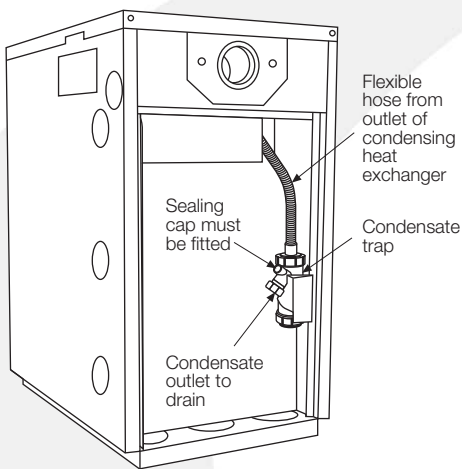

Figure 6-2: Condensate trap

The trap is factory-fitted inside the boiler casing at the rear of the boiler - mounted on the inside of the side panel - in an accessible position to allow for routine maintenance.

A flexible hose connects the outlet of the condensing heat exchanger to the trap inlet. Ensure the straight connector on the hose is fully pushed onto the 'top hat' inlet connector of the trap.

With the trap fitted inside the boiler casing, the sealing cap must be fitted in the trap outlet.



Care should be taken when siting the trap such that the overflow outlet is readily visible and that any condensate overflowing from the outlet cannot cause either a hazard to persons or damage to surrounding property or equipment.

## 6.7 Condensate Disposal Pipework

The condensate trap outlet is at an angle of 48° below the horizontal. This is to automatically give a 3° fall on any 'horizontal' runs of condensate disposal pipe. Refer to Fig.6-2 and see trap outlet/pipe.

The outlet of the trap will accept 21.5mm OD to 23mm OD Polypropylene overflow pipe for the condensate discharge pipe.

### Possible routes for disposal pipework

The casing of the Vortex Pro External boiler has several openings in both the sides and base of the casing. These are designed to allow pipework to pass through the casing, as required, to suit the installation. These openings can be used to allow the condensate disposal pipe to exit the casing in one of the following ways:

**Side outlet** - The lower opening on either side of the boiler casing can allow the condensate disposal pipe to be installed as follows:

- Connection to an internal stack - passing back through the wall of the house.
- Connection to an external soil stack adjacent to the boiler.
- Discharge into an adjacent (external) drain or gully.
- Discharge into a soakaway - with pipe either above or below ground level.

**Bottom outlet** - There are three openings in the base of the boiler casing that can allow the condensate disposal pipe to be installed as follows:

- Discharge into a drain or gully beneath the boiler (e.g. drain built in to the concrete base for the boiler).
- Discharge into a soakaway - with pipe below ground level.

## 6.8 Inspection and Cleaning of Trap

The trap **must** be checked at regular intervals (e.g. on every annual service) and cleaned as necessary to ensure that it is clear and able to operate.



**The bottom bowl is sealed to the trap body and cannot be removed.**

To inspect and clean the trap, perform the following procedure:

1. Disconnect flexible condensate hose from inlet connector.
2. Unscrew the inlet connection nut.
3. Remove the 'top hat' inlet connector and nut from trap.
4. Remove trap from bracket.
5. Remove float from trap - clean if necessary.
6. Inspect inside of trap and clean as necessary.
7. Re-assemble trap, re-fit to boiler and re-connect flexible hose. Ensure that hose is fully pushed onto the 'top hat' inlet connector.



**Failure to regularly check and clean the condensate trap may result in damage to the boiler and will not be covered by the Product Warranty.**

# 7 Sealed Systems

## 7.1 System Models

All Grant Vortex Pro External Combi e boilers are supplied as part of a sealed system that complies with the requirements of BS 5449.

The maximum temperature of the central heating water is 78° C.

### ! NOTE

**When designing a system, the pump head, expansion vessel size, and radiator mean temperature are amongst the factors that must be considered. See Section 4.6.**

The boilers are supplied with the following items factory fitted:

- A diaphragm expansion vessel complying with BS 4814, pre-charged at 1.0 bar, size as follows:  
10 litre for Vortex Pro Combi 21e  
12 litre for Vortex Pro Combi 26e  
14 litre for Vortex Pro Combi 36e.

- System pressure gauge, with an operating range of 1 to 4 bar.
- Pressure relief safety valve complying with BS 6759 and set to operate at 2.5 bar. The discharge pipe must be routed clear of the boiler to a drain, in such a manner that it can be seen, but cannot cause injury to persons or property.
- Automatic air vent, fitted to the top of the boiler, ensures the boiler is vented.
- Filling loop. This must be isolated and disconnected after filling the system.

Refer to Section 4.5 for further details of the expansion vessel.

### ! NOTE

**Ensure that the expansion vessel is of sufficient size for the system volume (including the volume of the boiler). If necessary a second vessel may need to be fitted to the system. Refer to Section 2.1 for system volume. To determine total vessel volume required refer to BS7074:1:1989 or the Domestic Heating Design Guide.**

The expansion vessel charge pressure should always be slightly greater than the maximum static head of the system, in bar, at the level of the vessel (1 bar = 10.2 metres of water). See Figure 7-1.

The system fill pressure (cold) should be 0.2-0.3 bar greater than the vessel charge pressure - giving typical system fill pressures of approx 0.5 bar for a bungalow and 1.0 bar for a two-storey house. Refer to the Domestic Heating Design Guide for more information if required.

If thermostatic radiator valves are fitted to all radiators, a system by-pass must be fitted. The bypass must be an automatic type.

Provision should be made to replace water lost from the system. This may be done manually (where allowed by the local Water Undertaking) using the filling loop arrangement supplied with the boiler.

Filling of the system must be carried out in a manner approved by the local Water Undertaking.

Where allowed, the system may be filled via the filling loop supplied (the loop arrangement includes a double check valve assembly).

All fittings used in the system must be able to withstand pressures up to 3 bar.

Radiator valves must comply with the requirements of BS 2767(10):1972.

One or more drain taps (to BS 2879) must be used to allow the system to be completely drained.

The expansion vessel is connected via a flexible hose to allow it to be moved to gain access to the baffle cleaning cover. When replacing the vessel, care should be taken to ensure that the flexible connecting hose is not twisted.

**If thermostatic radiator valves are fitted, the system must incorporate an adequate automatic by-pass.**

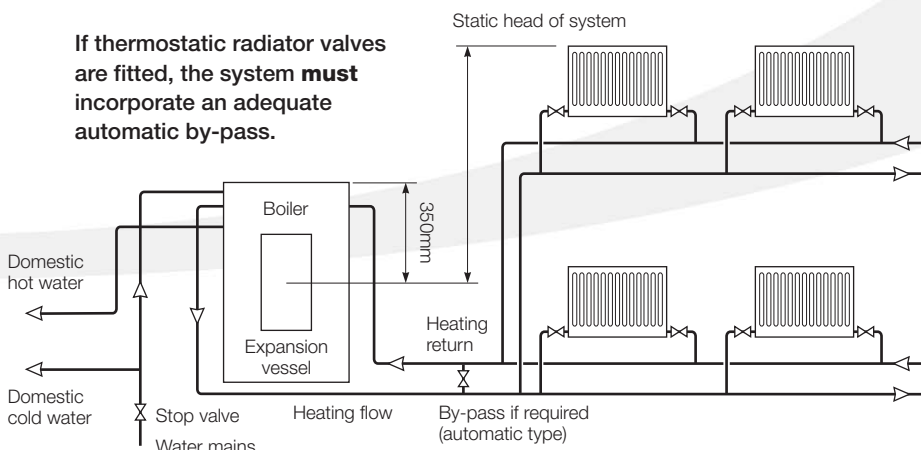

Figure 7-1: Sealed system

# 8 Electrical

## 8.1 Connecting the Power Supply



Ensure that the electrical supply has been isolated before making any connections to the boiler.

The boiler requires a permanent 230 V mains supply (fused at 5 Amp).

The Vortex Pro External Combi e is supplied fitted with an electrical isolation plug, located in the left hand end of the boiler control panel. All electrical wiring to the boiler must be made to this plug.

The isolation plug is connected to the power supply and heating / hot water controls as follows:

1. The isolation plug is located the control panel. Pull the plug to the left to remove it from the socket in the left hand end of control panel.
2. Remove the two screws and prise off the cover from the plug to gain access to the five terminals.



Pass the cable from the electrical power supply and heating / hot water controls through the cable clamp on the underside of the control panel before making connections to the isolating plug.

3. Connect the electrical supply and heating / hot water controls to the terminals in the isolating plug as follows:

- Terminal L1 - Heating on (from Timer, Thermostat or Programmer).
- Terminal L2 - Hot water on (from Programmer).
- Earth Terminal - Green / Yellow to mains Earth.
- Terminal N - Blue to mains Neutral.
- Terminal L3 - Brown to mains Live (including permanent live for Frost Thermostat).

The terminal numbers are marked on the top cover of the plug. Refer to Sections 8.3 and 8.4 for details of controls wiring BEFORE making connections to the isolating plug.

4. Replace the cover on the plug, refit the two screws and ensure it is securely fitted. Measure a maximum of 350mm of cable between the plug and the cable clamp below the control panel and tighten the cable clamp to secure the cable.



Check that the cable is securely clamped and that the cable length between the clamp and plug is no more than 350mm.

5. Re-fit the isolation plug into the socket in the control panel.



Do not switch on the electricity supply at this stage.



A Service switch is fitted to the control panel to allow the Service Engineer to test-fire the boiler.

When set to 'ON' the switch temporarily by-passes the external control system to operate the boiler.

This is a 'momentary' or non-latching switch that cannot be left set to ON. The boiler will automatically revert to normal operation when 15 minutes have elapsed since it was last operated. If required, this 15 minute override period can be stopped by switching the boiler On / Off switch OFF and then back to ON.

The boiler will then operate as normal under control of the external heating/hot water controls (timer, room thermostat or programmer).

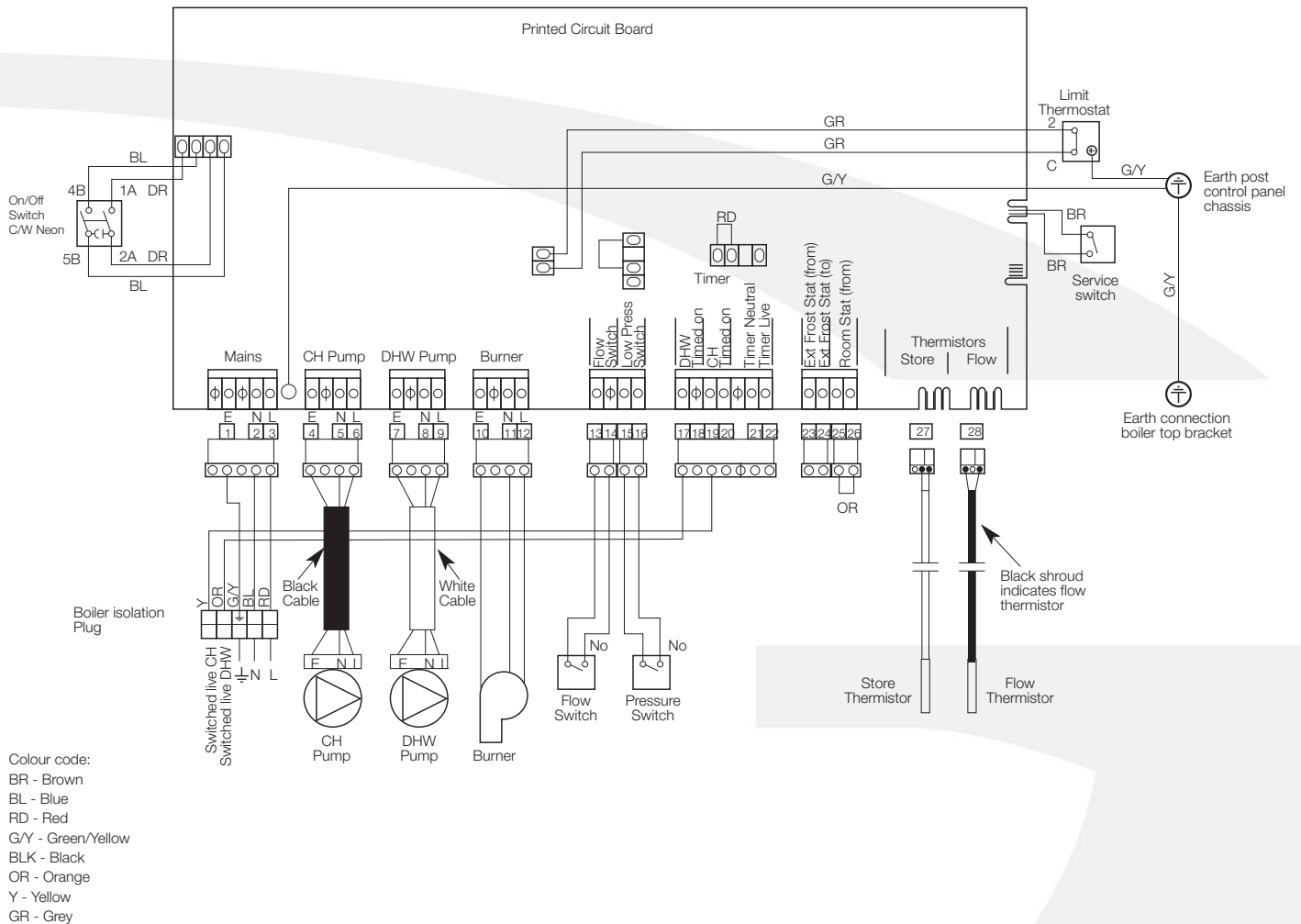

Figure 8-1: Boiler wiring diagram

### 8.2 Connecting the Controls - Heating Only

To control the central heating on / off periods only (and not the domestic hot water), it is recommended to use one of the following options:

- A single channel timer and room thermostat.
- A Grant programmable room thermostat (Ref. RSKIT).

Either of these options should be sited at a suitable and convenient location within the property.

The switched live from these central heating controls must be connected to Terminal L1 on the boiler electrical isolation plug. Refer to Figure 8-2 or Figure 8-3 as appropriate for connection details.

When using the boiler in this way, i.e. controlling the heating operation of the boiler only, a link must be fitted between terminals L2 and L3 in the isolation plug. This will enable the boiler to operate to supply hot water on demand at all times.

# 8 Electrical

## Connection of an external remote timer and room thermostat



### WARNING

Any remote timer must be of a single channel 230 V type with voltage free output contacts.

Connect the switched live output from the programmer/room thermostat to terminal L1 of the boiler isolation plug. Fit a link between terminals L2 and L3 in the isolation plug. Refer to Figure 8-2.

Connect the mains supply to the boiler isolation plug as follows (refer to Figure 8-2):

- Permanent live to terminal L3.
- Neutral to terminal N.
- Earth to earth terminal.

Re-connect the electrical supply and check the operation of the timer and room thermostat.

Refer to the Fitting & User instructions provided for with the timer for operating and setting.

Leave the Timer and Thermostat Fitting & User instructions with the user after installation.

## Connection of a Grant Programmable Room Thermostat (RSKIT)

Full Installation and User instructions are provided with the Grant Programmable Room thermostat.

Connect the programmable room thermostat as follows:

Connect the switched live output from terminal C of the programmable room thermostat to terminal L1 of the boiler isolation plug. Fit a link between terminals L2 and L3 in the isolation plug. Refer to Figure 8-3.

Connect the mains supply to the boiler isolation plug as follows (refer to Figure 8-3):

- Permanent live to terminal L3.
- Neutral to terminal N.
- Earth to earth terminal.

Re-connect the electrical supply and check the operation of the programmable room thermostat.

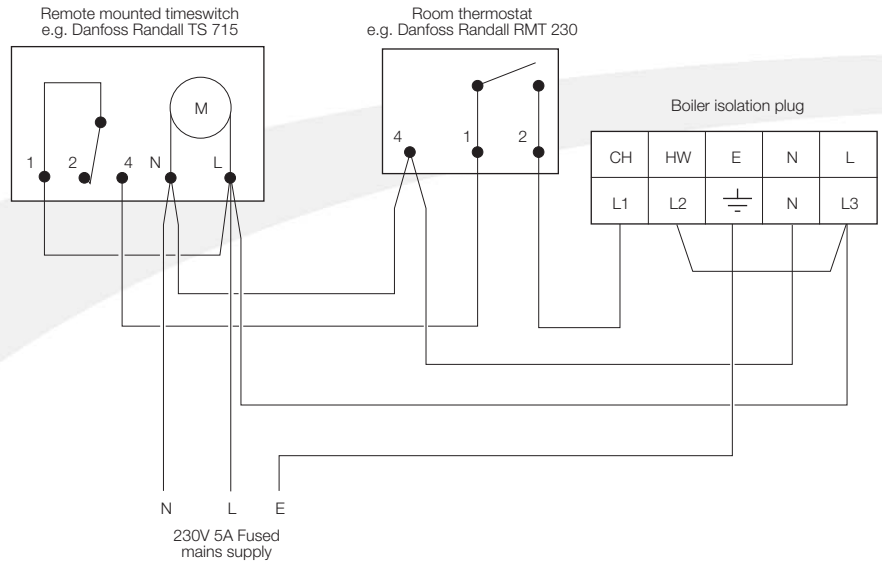

Figure 8-2: Connections for remote timer and room thermostat

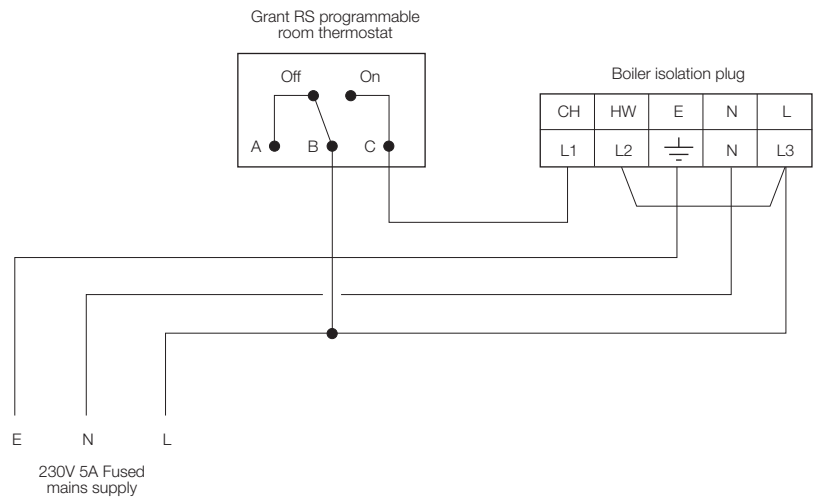

Figure 8-3: Connections for the Grant Programmable Room thermostat (RSKIT)

Refer to the Fitting & User instructions provided for with the programmable room thermostat for operating and setting.

Leave the Programmable Room Thermostat Installation and User Instructions with the user when installation is completed.

### 8.3 Connecting the Controls - Heating and Hot Water

If control of both the heating and hot water operation of the boiler is required, it is recommended to use one of the following options:

- a Grant 'wireless' RF two channel programmable room thermostat (Ref. RFTKIT), or
- a Grant two-channel programmer (Ref. ESKIT) and room thermostat.

#### NOTE

If either the RFTKIT or a two-channel programmer is used with the Vortex External Combi, the user must be made aware that if the hot water channel is left in the OFF position, hot water may not be available on demand, and that the primary store may need to recover before any hot water is available.

#### Fitting and connection of Grant two-channel 'wireless' Programmable Room Thermostat (RFTKIT)

Full Fitting and User instructions are provided with the Grant wireless RFT Programmable Room Thermostat kit.

The RF Receiver/switching unit (FM/2) for the RFT Programmable Room Thermostat is fitted in a wiring base that is located within the property. It is wired directly to the boiler isolation plug, on the control panel of the External Combi boiler. Refer to Figure 8-4 for connection details.

To connect the FM/2 receiver unit to the boiler, proceed as follows:

1. Remove the boiler front casing panel.
2. All electrical wiring is made to the Boiler Isolation plug – located at the left hand end of the boiler control panel.
3. Pull the plug to the left to remove it from the socket.
4. Remove the two screws and prise off the cover from the plug to gain access to the terminals.

**Pass the cable from the FM/2 wiring base through the cable clamp on the underside of the control panel before making connections to the plug.**

5. Connect the four wires from the FM/2 wiring base to the boiler isolation plug. Refer to Figure 8-4 and also the Fitting and User Instructions supplied with the RFT kit.
6. Connect the mains earth to the earth terminal on the boiler isolation plug – refer to Figure 8-4.

#### NOTE

There must be NO connection made from terminal 4 on the FM/2 unit

7. Replace the cover on the plug and secure with the two screws.
8. Measure a maximum of 350mm of cable between the plug and cable clamp, then tighten cable clamp to secure the cable.

9. Re-fit the isolation plug into the socket in the control panel.
10. Re-connect the electrical supply and check the operation of the controller. Refer to the Fitting and User Instructions provided for the setting and operation of the RFT Programmable Room Thermostat.

#### NOTE

Leave the Twin-channel Programmable Room Thermostat Fitting & User instructions with the user after installation.

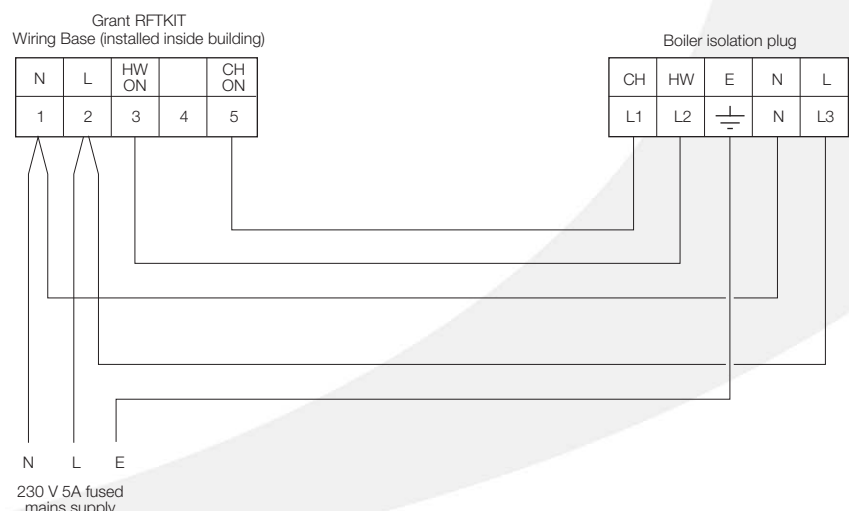

**Figure 8-4:** Connections for Grant wireless two-channel programmable room thermostat (RFTKIT)

# 8 Electrical

## Connection of external remote Programmer (for example, Grant ESKIT).

**NOTE**

A remote two-channel programmer must be suitable for 230 V and internally linked - for example, use the Grant Type ESKIT programmer.

Connect the switched live output from the Hot Water channel of the programmer (DHW ON terminal) to terminal L2 of the boiler isolation plug. Refer to Figure 8-5.

Connect the switched live output from the Heating channel of the programmer (CH ON terminal) to terminal L1 of the boiler isolation plug, via the room thermostat. Refer to Figure 8-5.

Connect the mains supply to the boiler isolation plug as follows (refer to Figure 8-5):

- Permanent live to terminal L3
- Neutral to terminal N
- Earth to earth terminal

If an alternative two-channel programmer to the Grant ESKIT is to be used, it must be suitable for 230 V and internally linked. Refer to Figure 8-5 for connection details.

Re-connect the electrical supply and check the operation of the programmer and room thermostat.

Refer to the Fitting & User instructions provided for with the programmer for operating and setting.

Leave the Programmer and Thermostat Fitting & User instructions with the user after installation.

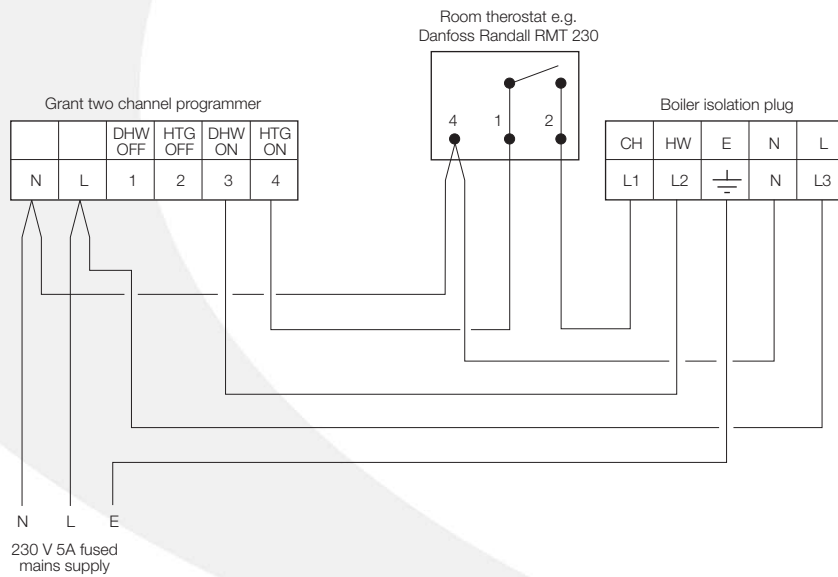

Figure 8-5: Connections for remote two-channel programmer (ESKIT) and room thermostat



#### 8.4 Connecting a Remote Frost Thermostat

The boiler is fitted with a pre-set internal frost protection thermostat. If either the air temperature around the boiler, or the water temperature within the boiler, fall to below 5°C, then this thermostat will be activated to protect the boiler from freezing.

If necessary, to protect the heating system or any exposed heating system pipework, a remote frost thermostat can also be connected to the boiler. This frost thermostat should be sited within the house in such a place that it can detect any rise and fall in the ambient temperature, that is, in a room with a radiator.

To connect a remote frost thermostat (for example, a Danfoss Randall RET230F), proceed as follows:

1. Remove the boiler door, top casing panel and insulation from boiler.
2. Remove the two screws at top of control panel (in cross member). Hinge down control panel front.
3. From rear of control panel, carefully feed the cable from the Frost thermostat through the upper grommet at the right hand end of the rear of the control panel.
4. Slacken the upper cable clamp on the inside rear face of the control panel. Feed the cable through the cable clamp.
5. Connect wires to terminals on control panel as follows:
  - Frost thermostat Neutral (N) to terminal 21 on PCB connector.
  - Frost thermostat Live (L) to terminal 24 on PCB connector.
  - Frost thermostat Switched Live-ON (3) to terminal 23 on PCB connector.
6. Refer to Figure 8-1 for typical connection of Remote Frost Thermostat.
7. If an alternative Frost thermostat to the Danfoss Randall RET230F is used, connect it in accordance with the frost thermostat manufacturer's instructions.
8. This external frost thermostat will operate in parallel with the internal frost thermostat.
9. Re-tighten cable clamp. Re-fit control panel front and secure using the two screws.
10. Re-connect the electrical supply.

# 9 Flue System and Air Supply

## 9.1 Low Level Discharge Flue

The Grant VORTEX Pro External combi is supplied with a low level discharge flue (see Section 4).

The minimum dimensions for locating the standard terminal from building features (windows, doors, etc.) are shown in Figure 9-1.

The terminal must be positioned so as to avoid products of combustion

accumulating in stagnant pockets around the buildings or entering into buildings. Care should be taken that the plume from condensed flue gases does not cause a nuisance.

Where it is not practical to use this flue, the External module may be fitted with an alternative flue system available from Grant UK.

### NOTE

Under no circumstances can the External module be installed with an existing flue system. Only Grant flue systems and components suitable for wet flues should be used.

Failure to install the correct type of flue system will invalidate the warranty.

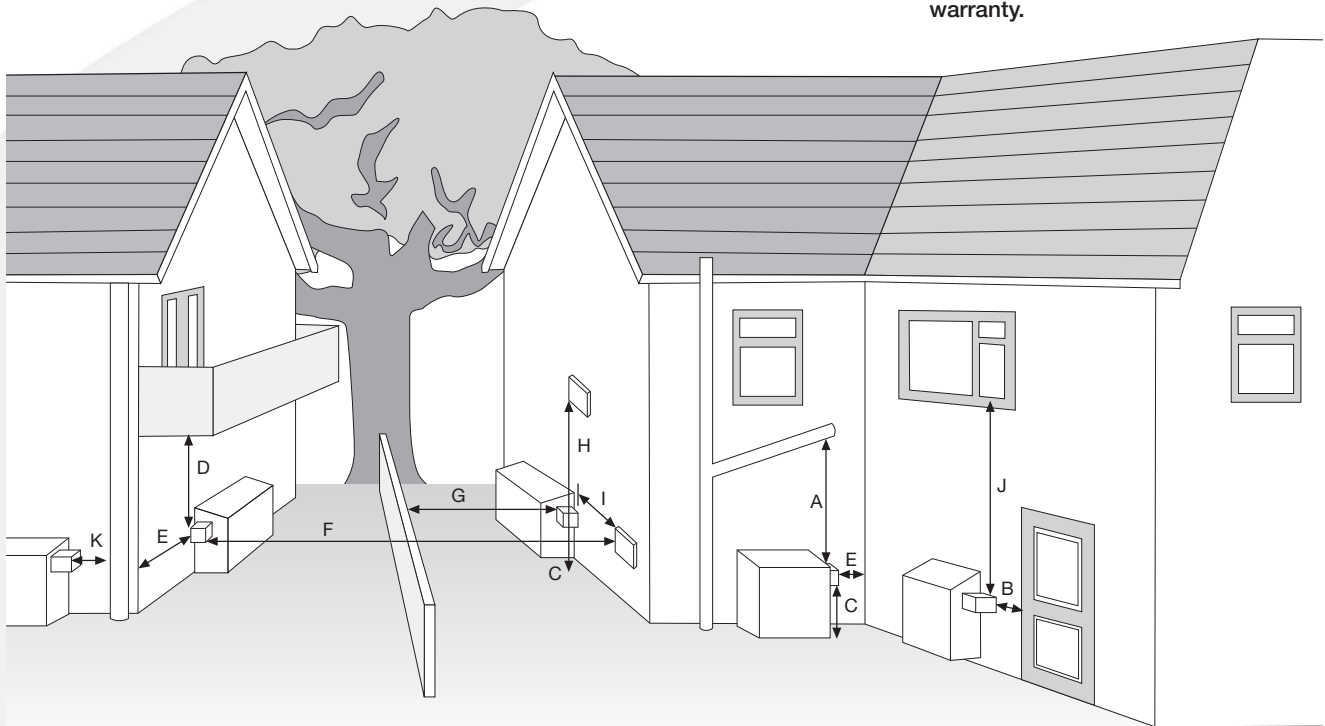

Figure 9-1: Clearances for low level discharge flues

Key	Terminal position	Min. distance (mm)
A	Below a gutter or sanitary pipework	600*
B	Horizontal from an opening, air brick or window	600
C	Above ground or balcony level	300
D	Below eaves or balcony	600*
E	From an internal or external corner	600
F	From a terminal facing the terminal	1200
G	From a surface facing the terminal	600
H	Vertical from terminals on the same wall	1500
I	Horizontal from terminals on the same wall	750**
J	Below an opening, such as an air brick or window	600
K	From vertical sanitary pipework	300
	From an oil storage tank	1800

#### Notes:

\* 75mm with protection.

\*\* Only applies if one or both terminals are balanced flues.

The terminal should be positioned so as to avoid products of combustion accumulating in stagnant pockets around the building or entering into buildings. Care should also be taken to ensure the plume from the condensed flue gases does not cause a nuisance.

Distances measured to rim of terminal. Clearances recommended by Grant Engineering (UK) Limited in accordance with British Standards and Building Regulations.

### NOTE

1. An opening means an openable element, such as an openable window, or a permanent opening such as a permanently open air vent.
2. Notwithstanding the dimensions given, a terminal should be at least 300mm from combustible material, e.g. a window frame.
3. A way of providing protection of combustible material would be to fit a heat shield at least 750mm wide.

### 9.2 Grant Green System

This vertical twin wall stainless steel insulated flue system – constructed using components from the Grant Green system – connects to a Grant Starter elbow and may terminate at high level or vertically (above the roof) as required. See Figure 9-2.

The insulated Starter elbow provides the boiler connector, complete with test point, replacing the low level terminal and flue guard supplied with the boiler.

### 9.3 Grant Hybrid System

This vertical option allows the use of an existing chimney using part of the 'Green' system and the flexible liner and terminal of the Grant 'Orange' system. See Figure 9-3.

If an existing chimney is to be used, it must be lined with a smooth bore stainless steel liner suitable for use with oil fired condensing boilers. The top and bottom of the annular space must be sealed.

Grant recommends the use of the Grant 'Orange' flue system, specifically designed for the VORTEX range of condensing boilers.

The internal flue and liner diameter for all combi models must be 100mm (4 in).

The maximum vertical height (from the top of the boiler to the terminal) for the 'Orange' system is 19 metres.

Figure 9-2: Outdoor high level flue (Green system)

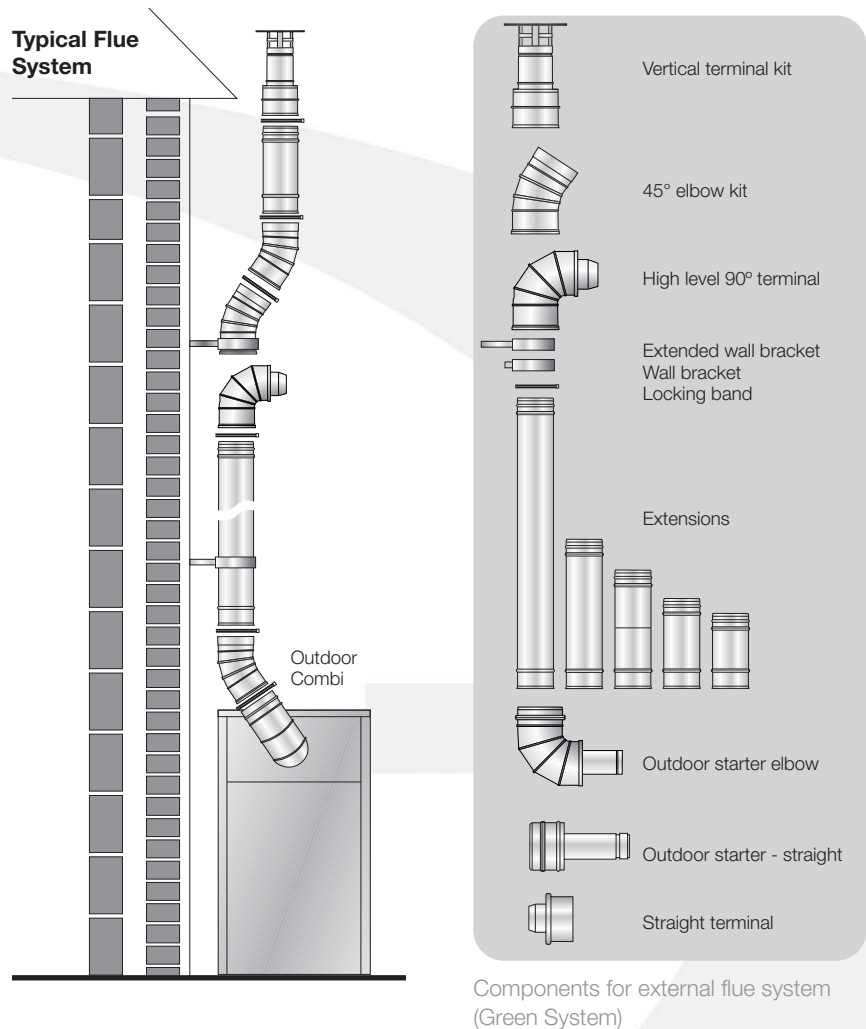

### ! NOTE

The Grant Orange system flexible stainless steel liner is directional. The arrows marked on the liner **MUST** be pointing vertically upwards, following the direction of the flue gases. Failure to comply with this instruction could lead to a leakage of condensate from the flue liner.

### ! NOTE

In order to correctly connect the Grant hybrid system to the boiler, it will be necessary use the Grant Starter Elbow.

This insulated Starter elbow provides the boiler connector, complete with test point, replacing the low level terminal and flue guard supplied with the boiler.

# 9 Flue System and Air Supply

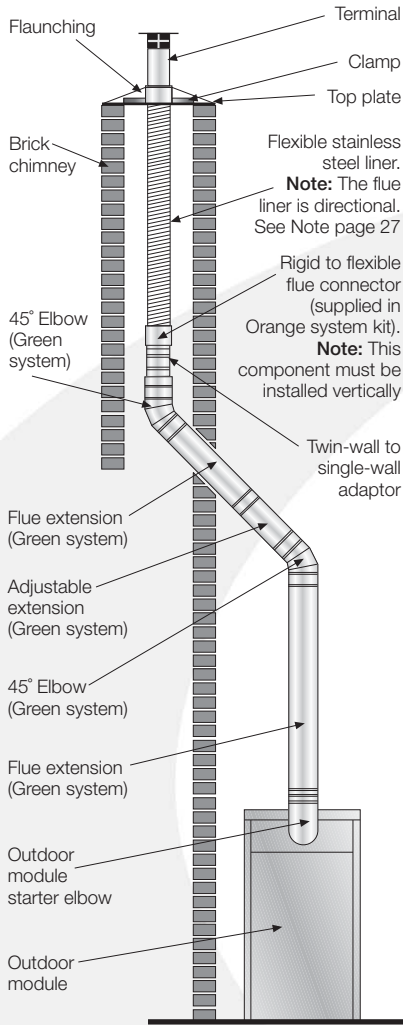

Figure 9-3: Vertical hybrid flue (Green to Orange system)

## 9.4 Grant Horizontal System

This option uses the Grant Straight Starter boiler connector, replacing the low level terminal and flue guard supplied with the boiler, along with components from the Grant Green system. See Figure 9-4.

A complete list of Grant Green system flue components are given on page 29.

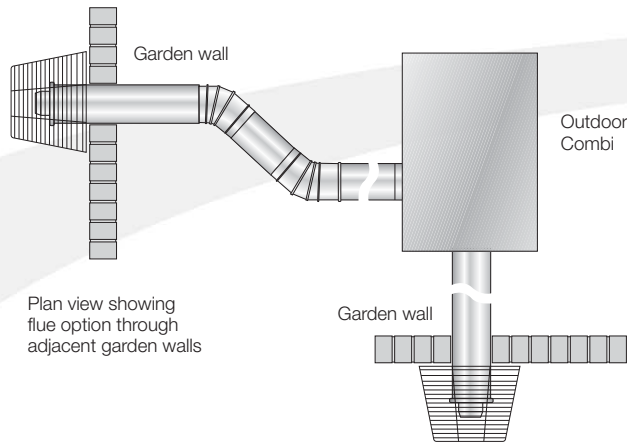

Figure 9-4: Outdoor horizontal flue system (Green system)

## 9.5 General Guidance

All flue components are stainless steel and fully insulated with 'O' ring seals and locking bands.

**The flue must terminate in a down draught free area, i.e. at least 600mm above the eaves or point of exit through the roof, or preferably above the ridge level.**

The condensate may be allowed to run back into the boiler. A condensate drain at the base of the flue system is not required.

**The flue terminal must be at least 600mm from any opening into the building, and 600mm above any vertical structure or wall less than a horizontal distance of 750mm from the terminal.**

No part of any flue system should be made of an asbestos material; aluminium must not be used in any part of the flue. Only stainless steel flue components should be used.

If the draught conditions are satisfactory, the flue should terminate with a standard cowl.

Refer to the locally applicable Building Regulations, BS 5410:1 and OFTEC Installation Requirements (OFTEC Technical Book 4) for further guidance on conventional flue systems.

## 9.6 Air Supply

A permanent air supply must be provided to the burner, sufficient to ensure proper combustion of fuel and effective discharge of combustion products to the open air.

The ventilation openings provided in the upper part of the front door of the boiler casing must not be obstructed at any time.



**It is important to ensure that the flue system is sealed and that condensate cannot escape. Up to 1.5 l/h of condensate can be produced in a conventional flue system.**

**Do not use fire cement. The use of high temperature silicone sealants is recommended.**



**To comply with the requirements of the Building Regulations Approved Document J - conventional flue systems must have a flue data plate. A suitable data plate is supplied with the current orange flue system and should be displayed next to the boiler or flue.**

# 10 Commissioning

It is important that the following commissioning procedure is carried out to ensure safe and efficient operation of the boiler.

To access the controls, remove the front panel (turn the handle and withdraw it forwards at the bottom).

The controls are shown in Figure 10-1.

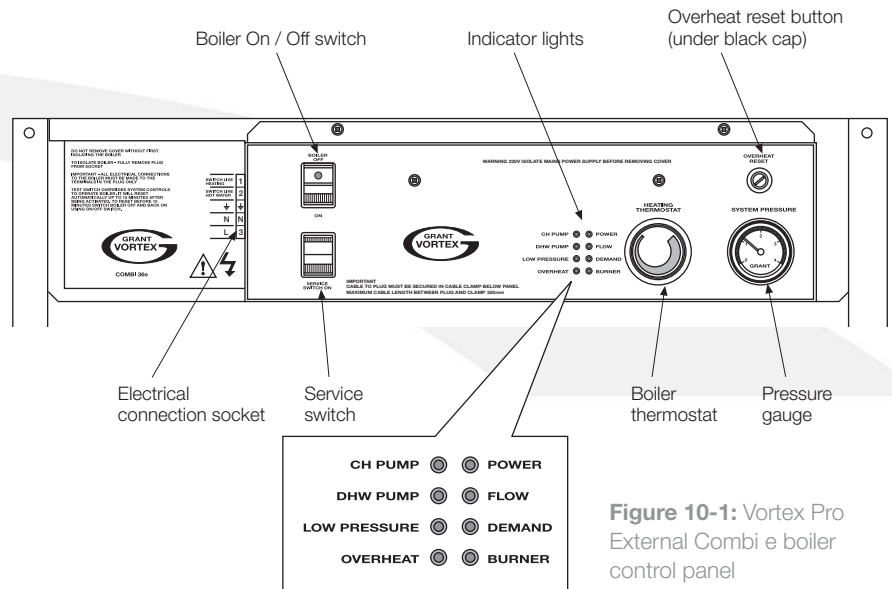

**Figure 10-1:** Vortex Pro External Combi e boiler control panel

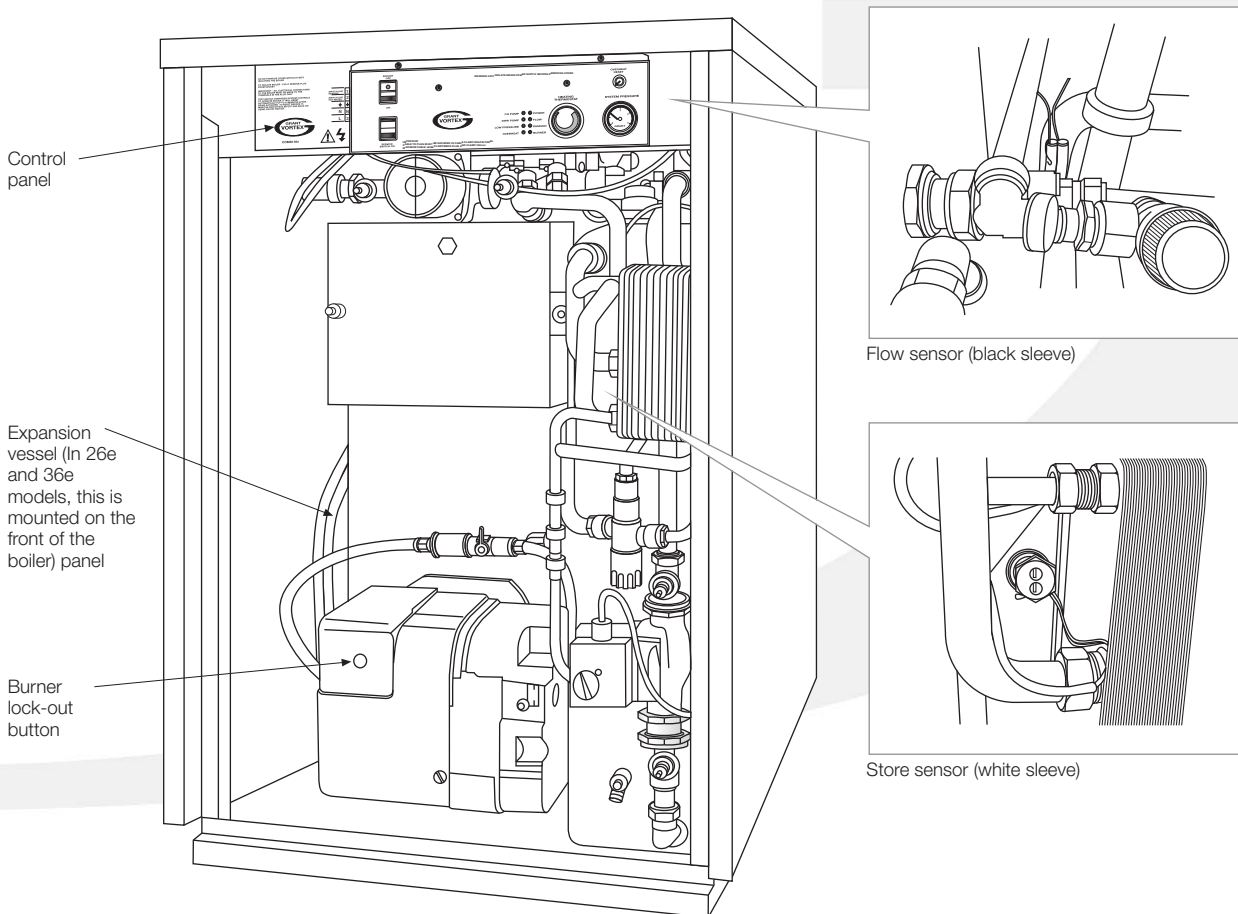

**Figure 10-2:** Vortex Pro Combi 21e boiler with front panel removed showing position of control panel

# 10 Commissioning

## 10.1 Before Switching On

1. Ensure the boiler On/Off switch is set to OFF.
2. Check that the high limit thermostat bulb and both thermistor sensors are correctly located in their respective pockets. Refer to Figure 10-2. Check condition of both thermistor cables and thermostat capillary. Ensure they are not damaged, broken, kinked or crushed.
3. Remove the nuts and washers securing the front cleaning door. Withdraw the door – take care as it is HEAVY!
4. Check that the turbulators are in position and that the ends are vertical. Refer to Figure 11-4.
5. Check that the baffles are in position. Refer to Figures 11-1, 11-2, or 11-3 as required.
6. Re-fit cleaning door and check it is fitted correctly and that a good seal is made.
7. Remove and check the burner. Check burner head is correct. Refer to Section 2.3 and Figures 13-2, 13-3 or 13-4 as required.  
Check electrodes are set correctly. Refer to Figure 11-5.  
Check the nozzle is correct for the output rating required. Refer to Section 2.3.  
Check burner air adjuster disc is set to setting C (Vortex Combi 21e only). Refer to Figure 10-4.
8. Check that the sealed system has been vented and pressurised and there are no leaks.
9. Ensure both automatic air vents, and also the manual vent on the flow pipe, are open.
10. Check that all fuel line valves are open.
11. Remove the plastic burner cover if it was not previously removed.
12. Connect a combined vent manifold and pressure gauge to the pressure gauge connection port on the oil pump. See Figure 10-3.
13. Check that all system controls are calling for heat and turn the boiler thermostat to maximum.

## 10.2 Switching On

1. Switch on the electricity supply to the boiler.
2. Set the boiler On/Off switch to ON. A neon on the switch lights when it is in the ON position. The burner should fire.  
The burner fan should start and the burner should light within about 12 seconds. If the burner does not light and the 'Lock out' reset button lights, wait for about 45 seconds then press the reset button to restart the ignition process. This procedure may have to be repeated during first lighting.  
Open the vent screw on the vent manifold to vent the supply while the oil pump is running.  
Note that the neon lights when the boiler is switched on, but does not necessarily indicate the burner is firing.
3. Fully open a hot tap and allow it to run for a few moments to vent the internal primary circuit. The Hot Water pump will operate and the burner should light within about 12 seconds.
4. Close the hot tap. The burner will continue to fire to heat the primary water in the boiler or primary store until the required temperature is reached.

### NOTE

**Grant Vortex e Combi boilers incorporate a “pump overrun” feature, within the control circuit board, that operates as follows –**

#### **When reheating the Primary Hot Water store;**

the burner will cut out when the boiler reaches 83°C (as detected by the boiler “flow” thermistor).

#### **If there is a demand for Central Heating;**

the hot water “store” pump will run on for 90 seconds before it stops and the “central heating” pump then comes in.

#### **If there is no demand for Central Heating;**

the hot water “store” pump will continue to run until the temperatures in the Primary Hot Water store and the boiler

have equalised. **The adjustable Boiler thermostat on the control panel regulates the boiler temperature when in Heating mode only. The recommended flow temperature setting is 70°C.**

**The Primary Hot Water store temperature is controlled via the “store” thermistor and control circuit board. The control thermostat has NO influence on either the store temperature or the hot water temperature at the tap.**

### NOTE

**The Hot Water pump will continue to run for a short period after the burner has stopped.**

The boiler will now be operating in the central heating mode.

### NOTE

**The burner may not fire immediately in the central heating mode.**

5. With the burner alight, check the fuel pressure. Refer to the Technical Information, Section 2.3.
6. Adjust the pressure if necessary - see Figure 10-3.

### NOTE

**It is important that the oil pressure is correctly set.**

7. Operate the boiler until it reaches normal operating temperature. Check oil supply/return pipe for leaks, rectifying where necessary.
8. Check the operation of the boiler thermostat. Ensure that by turning it anticlockwise it switches the burner off.
9. With the burner alight, re-check the fuel pressure and re-adjust if necessary. Turn the boiler off, remove the pressure gauge and replace the plug in the pump.
10. Ensure that there are no oil leaks, replace the burner cover.

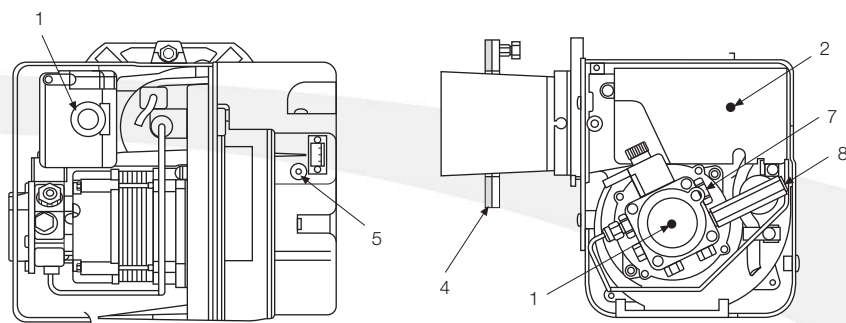

Figure 10-3: RDB burner components

1. Pump
2. Control box
3. Reset button with lockout lamp
4. Flange with gasket
5. Air damper adjustment screw
6. Air supply tube connection (balanced flue)
7. Pump pressure adjustment screw
8. Pressure gauge connection

### 10.3 Running the Boiler

1. Relight the boiler and allow it to run for at least 20 minutes.
2. Check the smoke number, if satisfactory check the CO<sub>2</sub>. Set the CO<sub>2</sub> to the value given in Section 2.3 for the boiler concerned.

#### NOTE

Final combustion readings can only be measured outside through the low level flue terminal (or the test point on the conventional flue starter elbow when used) with all the casing panels fitted.

3. Use the hexagonal key supplied to adjust the burner air damper (see Figure 10-3) as required. Turning the screw anti-clockwise closes the damper and increases CO<sub>2</sub> level, turning the screw clockwise opens the damper and reduces CO<sub>2</sub> level.
4. Re-check the smoke number if the damper has been moved. Under no circumstances must the smoke number be above 1.

#### NOTE

It is important that the air damper is correctly set.

5. Check the flue gas temperature by placing the combustion analyser in the low level flue terminal (or into the test point on the starter elbow if either the Green system or Hybrid system is used).

### 10.4 Balancing the System

1. When the boiler has been adjusted and is running satisfactorily, balance the central heating system by adjusting the radiator lock shield valves. Start with the radiator nearest the boiler and adjust the valves to achieve the required temperature drop across each radiator. If thermostatic radiator valves have been installed, check the system bypass.
2. Switch off the boiler.

### 10.5 Completion

1. With the system hot, check again for leaks, rectifying where necessary. Drain the system while it is hot to complete the flushing process. Refill and vent the sealed system.
2. A suitable central heating system inhibitor must be added to protect the system against the effect of corrosion.
3. A suitable antifreeze should be used to prevent damage to the boiler in areas where electrical power failure can occur in winter months.
4. Replace the top, front and rear panels as necessary.

#### NOTE

After commissioning the boiler complete the **Commissioning Report** in the front of this manual and the **OFTEC CD/11 commissioning report**. Leave the top copy with the User and retain the carbon copy.

If the boiler is to be left in service with the User, set the controls and room thermostat (if fitted) to the User's requirements.

If the boiler is not to be handed over immediately, close the boiler fuel supply valve and switch off the electricity supply.

#### CAUTION

If there is any possibility of the boiler being left during frost conditions, then the boiler and system should be drained. Alternatively, a suitable antifreeze should be used.

#### NOTE

To allow the boiler to be commissioned and serviced correctly a combustion test point is provided on the front cleaning door.

The CO<sub>2</sub> and smoke test may all be carried out using this test point.

**The test point is not suitable for measuring boiler efficiency or conventional flue draught.**

When using the test point on the cleaning cover note that the flue gas temperature reading will be higher than that measured in the flue thus resulting in an inaccurate efficiency reading.

To obtain an accurate flue gas temperature and efficiency, the reading can only be measured outside through the low level flue terminal ( or the test point on the conventional flue starter elbow when used) with all the casing panels fitted.

# 10 Commissioning

## 10.6 Air Adjuster Disc – Combi 21 only

The Riello RDB 2.2 burner fitted to this boiler incorporates a secondary air adjustment shutter located within the air inlet housing.

It is essential that this internal shutter disc be correctly set to position 'C'. Refer to Figure 10-4.

To access the air adjuster disc:

1. Ensure the boiler is isolated from the electrical supply.
2. Remove the burner from the boiler.
3. Undo the two screws and remove the air inlet cover from the side of the burner.
4. The secondary air shutter disc is factory set in position 'C' – i.e. with the cut-out marked C located against the die-cast boss on the fan housing. See Figure 10-4.
5. If not set to position 'C': remove the screw from the centre of the air shutter disc, and re-position it such that the cut-out 'C' is located against the cast boss on the fan housing. Replace the screw in the centre of the air shutter disc and tighten.
6. Re-fit the air inlet cover to the side of the burner and reassemble in reverse order.

## 10.7 Information for the User

The User must be advised (and demonstrated if necessary) of the following important points:-

- How to start and switch off the boiler and how to operate the system controls.
- The precautions necessary to prevent damage to the central heating system and to the building, in the event of the boiler not being in operation during frost conditions.
- The importance of servicing the boiler to ensure safe and efficient operation. This should normally be required only once a year.
- The type of fuel used.
- That any servicing or replacement of parts must only be carried out by a suitably qualified engineer.
- Ensure that the boiler controls and room thermostat (if fitted) are set to the User's requirements.
- Tell the User the system pressure and show them the position of the safety valve discharge pipe.
- Show the User how to reset the overheat thermostat and how to restart the boiler if it goes to 'Lock-out'.



## NOTE

Leave this Instruction manual with the User.

Ensure the User information pack has been given to the Householder.

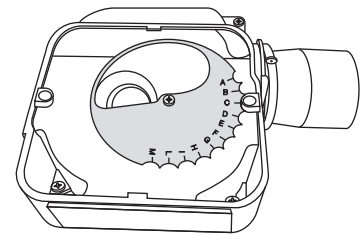

Figure 10-4: Burner air adjuster disc (shown set to position C)



# 11 Boiler Servicing

To ensure efficient operation of the boiler it is recommended that it is checked and serviced as necessary at regular intervals. The frequency of servicing will depend upon the particular installation conditions and usage, but in general once per year should be adequate.

Servicing and replacement of parts must only be carried out by a suitably qualified engineer.

## CAUTION

Details of every service should be entered in the Service Log, in the Boiler Handbook.

This information may be required to validate the Grant extended warranty.

## WARNING

Before starting any work on the boiler, or fuel supply please read the health and safety information given in Section 14.

### 11.1 Checking before Servicing

The following sequential checks should be made before any servicing:

1. Check the flue terminal and ensure it is not blocked or damaged.
2. Run the boiler and check the operation of its controls.
3. Ensure that all water / fuel system connections and fittings are sound. Remake any joints and check the tightness of any fittings that may be leaking.
4. The boiler is part of a sealed central heating system; check the system pressure, check the operation of the pressure relief valve and check the expansion vessel air charge. See Section 7.
5. Refill, vent and re-pressurise the system as necessary. See Section 4.

6. Check that the ventilation openings in the casing are clear. See Section 9.
7. Remove any sludge / water from the fuel tank by opening the sludge valve at the lower end of the tank.
8. With the fuel supply valve closed, clean / replace the filter element and clean the filter bowl.

Braided flexible fuel supply hoses as supplied with the boiler should be replaced annually when the boiler is serviced. If long-life hoses have been installed, these should be inspected annually. If in doubt replace the hoses. In any event, these hoses must be replaced every five years.

## WARNING

Before servicing, set the boiler On / Off switch to Off, isolate the electricity supply and close the fuel supply valve.

Allow the boiler to cool.

The data label on the inside of the case side panel will indicate the fuel used and the nozzle fitted.

### 11.2 Dismantling Prior to Servicing

The procedure for dismantling the boiler is as follows:

1. Remove the front panel.
2. Carefully lift up and remove the expansion vessel from the boiler.
3. Remove the burner fixing nut (top of mounting flange) and withdraw the burner.

## NOTE

If two flexible pipes are connected to the burner, identify (mark if necessary) which is the suction and return if they are to be disconnected.

### 11.3 Cleaning the Boiler

The procedure for cleaning the boiler is as follows:

1. Remove the nuts and washers securing the front cleaning door and withdraw the door. Take care - it is heavy.
2. Remove the baffles as shown in Figure 11-1, Figure 11-2 or Figure 11-3, as appropriate.
3. Remove all deposits from the baffle plates and all the boiler internal surfaces using a stiff brush and scraper if necessary.
4. Check the condition of the flue, clean as necessary.
5. Check the condition of the front cleaning door seal and replace if necessary.
6. Replace the baffles, ensuring they are correctly fitted. See Figure 11-1, Figure 11-2 or Figure 11-3, as appropriate. Pull out the spiral turbulators from the heat exchanger tubes. See Figure 11-4.
7. Clean the turbulators using a stiff brush.
8. Test the heat exchanger condensate drain by pouring water into one of the lower tubes and observe whether the water discharges from the 22mm condensate outlet. Replace the turbulators.
9. Replace the front cleaning door, ensuring the seal is in good condition and secure it in position with the nuts and washers previously removed. Tighten to form a seal.
10. Remove the condensate trap and check that it is not blocked and is operating correctly, i.e. the float is free to move. Clean the trap and float as required.
11. Check that the boiler condensate outlet is unobstructed. Clean if necessary.

## NOTE

The condensate trap and condensate outlet must be checked on every service and cleaned as necessary.

# 11 Boiler Servicing

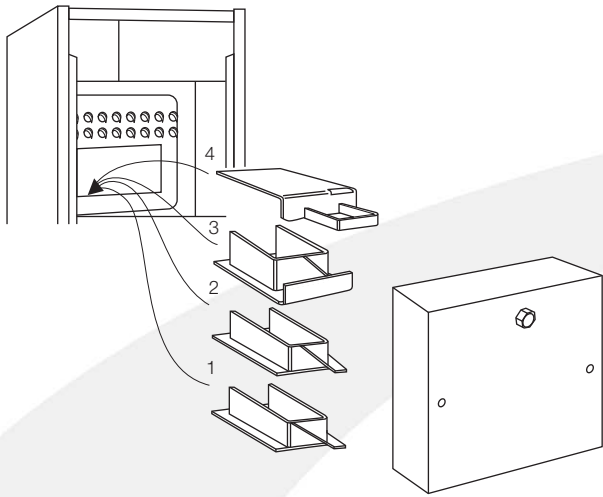

Figure 11-1: Baffles in Vortex Pro Combi 21e

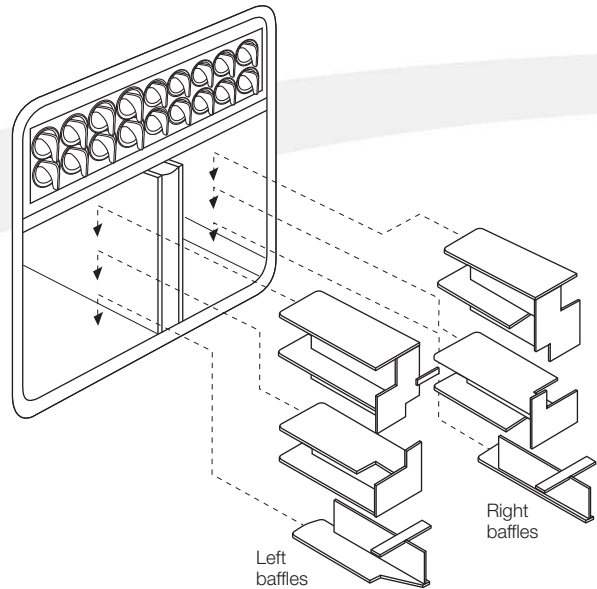

Figure 11-2: Baffles in Vortex Pro Combi 26e

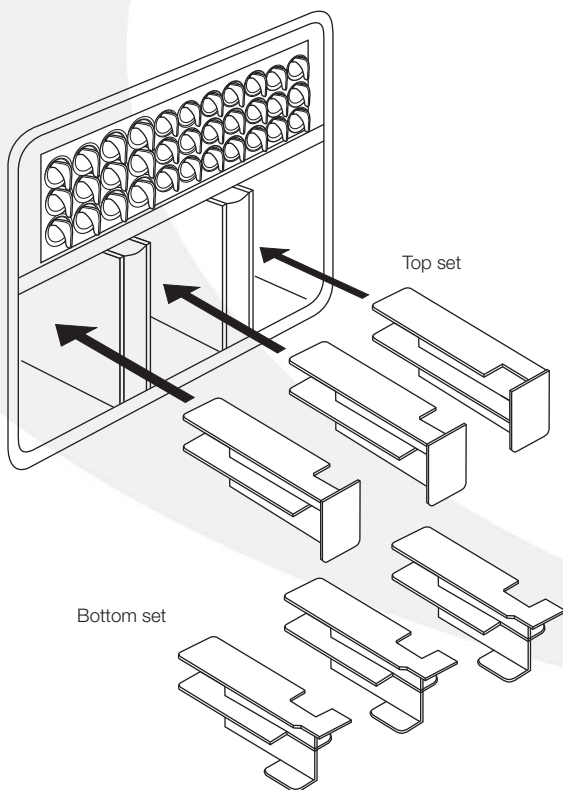

Figure 11-3: Baffles in Vortex Pro Combi 36e

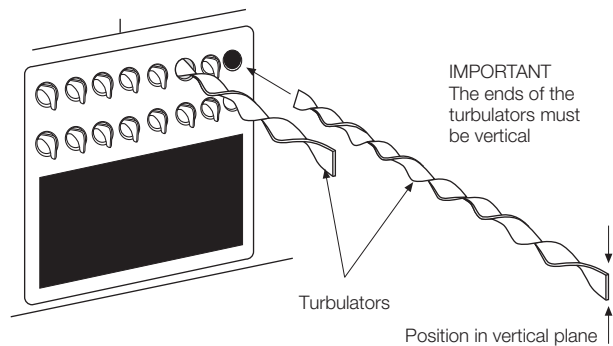

Figure 11-4: Turbulators in Vortex Pro Combi e boilers

## 11.4. Cleaning the Burner

The procedure is:

1. Combustion head - Loosen the two screws securing the combustion head and withdraw the head.
2. Clean the combustion head.
3. Inspect the ignition electrodes - Loosen the electrode clamp screw and withdraw the electrode assembly. Wipe clean and check for any cracks in the ceramic insulation. Replace if necessary.
4. Check the electrode settings as shown in Figure 11-5.
5. Nozzle - The nozzle should be replaced on an annual service - Check that the nozzle size and type are correct, refer to table in Section 2 and boiler data label.
6. With the combustion head removed, loosen the electrode assembly clamp screw and slide the electrodes away from the nozzle.
7. Do NOT attempt to clean the nozzle.
8. Remove the nozzle using a good fitting spanner (16mm).



### CAUTION

The use of an ill-fitting spanner will damage the nozzle and could lead to an incorrect flame pattern.

9. Always check the electrode settings after replacing the nozzle, see Figure 11-5.
10. Refit the combustion head.

#### All models

**Photocell** - The photocell is a push-fit in the burner body. Carefully pull out the photocell to clean.

**Burner fan** - Remove the air intake from the burner. Check, inspect and clean the fan as required.

Replace the cover.

**Pump filter** - Remove the four screws securing the pump end cover. Remove the filter and wash in kerosene. Replace the filter and end cover, ensure the 'O' ring is in position.

Re-assemble in reverse order.



### WARNING

To ensure safe and efficient operation of the boiler it is important that re-commissioning is carried out, especially combustion checks (CO<sub>2</sub> level, flue gas temperature and smoke number) after the boiler has been serviced.

Refer to the Commissioning instructions in Section 10.

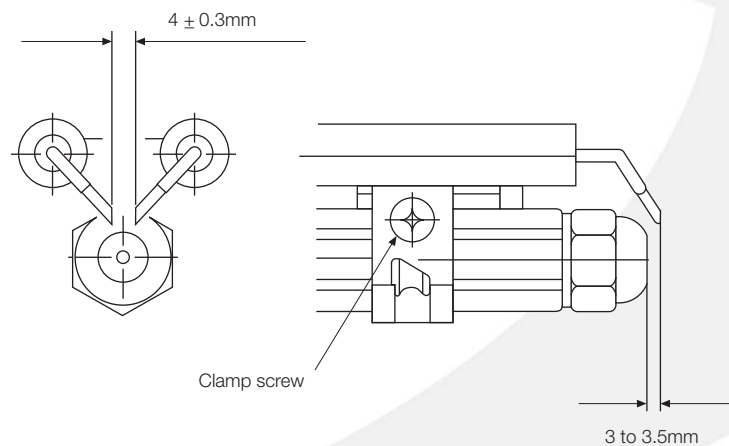

Figure 11-5: Electrodes showing settings

# 12 Fault Finding

## 12.1 Initial Checklist - for Installer or Service Engineers

### If the Boiler Fails to Light

First follow the procedure below

Power Supply	<p>Check that fused spur for heating system and boiler is switched on.</p> <p>Check that fuse has not blown.</p> <p>Check that electricity supply has not failed: check circuit breaker in consumer unit.</p>
Heating System Controls	<p>Check that timer or programmer is working and set to an 'ON' period.</p> <p>Check that all thermostats are set to the required temperature and are 'calling' for heat.</p>
Boiler Controls	<p>Check boiler 'On/Off' switch is set to 'ON'.</p> <p>Check that "POWER" indicator on the control panel is lit.</p> <p>Check that "DEMAND" indicator is lit.</p>
Burner	<p>Check if the burner 'Lockout' reset button (on front face of burner) is lit.</p> <p>If YES: press in the reset button to start the burner.</p> <p>If burner fails to light and goes to 'Lockout' again refer to section 12.4.</p>
Heating System	<p>Check Heating System water pressure.</p> <p>Check if "LOW PRESSURE" indicator is lit.</p> <p>If YES: system water pressure has fallen to below 0.2 bar and the low pressure cut-out has been activated.</p> <p>Re-fill system to increase pressure to between 0.5 and 1.0 bar.</p>
If Burner Still Fails to Light	Follow the ' <b>BURNER NOT OPERATING</b> ' procedure in Section 12.2(C).

### For Hot Water – ALL the following indicator lights MUST be lit

POWER	If NOT lit this indicates a problem with power supply to the boiler - switched off or possibly a blown fuse.
DHW PUMP	<p>If FLASHING this indicates either a 'Store' thermistor or PCB fault.</p> <p>Refer to 'Is the "DHW PUMP" Indicator flashing' procedure in Section 12.2 (B)</p>
FLOW	If not lit when a hot tap is opened this indicates either lack of water flow or possible flow switch problem.
DEMAND	If not lit this indicates either timer/programmer is not 'calling' for hot water or 'Hot Water' switch is not set to 'CONSTANT'.
BURNER	<p>If flashing this indicates PCB fault.</p> <p>Refer to '<b>Is the "BURNER" indicator lit</b>' procedure in Section 12.2 (B)</p>

NOTE: There may be a delay before the "BURNER" indicator is lit when the store is up to temperature

**For Night Time Hot Water Function – ALL the following indicator lights MUST be lit**

POWER	If NOT lit this indicates a problem with power supply to the boiler - switched off or possibly a blown fuse.
DHW PUMP	If FLASHING this indicates either a store thermistor or PCB fault. Refer to ' <b>Is the "DHW PUMP" Indicator flashing</b> ' procedure in Section 12.2 (B)
FLOW	If not lit this indicates either a lack of water flow or a possible flow switch problem.
DEMAND	If not lit this indicates either timer/programmer is not 'calling' for hot water or 'Hot Water' switch is not set to 'CONSTANT'.
BURNER	If flashing this indicates PCB fault. Refer to ' <b>Is the "BURNER" indicator lit</b> ' procedure in Section 12.2 (B)

NOTE: The "DHW PUMP" indicator may be lit if the boiler is operating to heat the store which has priority over the CH operation. There may be a delay before the "BURNER" indicator is lit when the the store is up to temperature.

For further guidance refer to the Main Fault Finding Procedures – Section 12.2.

**12.2 Main Fault Finding Procedures**

**A. No Central Heating - but Hot Water OK**

**First - Set Hot Water switch to OFF**

Is the "DEMAND" indicator lit?	NO	Check programmer/timer and room thermostat are calling for heating.
	NO	Check 'Heating' switch is set to 'TIMED'.
Is the "CH PUMP" indicator lit?	YES PCB is supplying voltage to the CH pump – but pump is not working.	Check electrical connections at the pump. Check for 230V at the pump terminals. Check if CH pump is stuck: Remove pump vent screw and check for Rotation of shaft/impeller. If stuck: Rotate shaft manually to restart. If still not operating; Replace the CH pump. NOTE: A 6 metre pump must be used.
	YES CH pump is working but no circulation.	Check both pump valves are open. Check Non-return valve on CH pump is operational (not sticking). Check there are no air locks in the system. (if removal of air lock is difficult – see additional check list). Check the pump impeller is attached to the shaft.
Is the "CH PUMP" indicator lit?	NO	Check Non-return valve on CH pump - is it stuck blocked open - check/rectify. Note – CH return will be hotter than flow if CH non-return valve is jammed open. Check by closing one heating pump valve to stop circulation - does the store then come up to temperature? If problem is not due to CH non-return valve - continue to next check.
Is the "CH PUMP" indicator flashing?	YES Fast or Slow flash.	First – set boiler 'On/Off' switch to 'OFF'. Wait 5 seconds. Then set 'On/Off' switch back to 'ON'.
If the "CH PUMP" continues flashing.	Fast flash (twice per second): Indicates a possible fault with the 'Flow' thermistor.	Check CH 'Flow' thermistor connection to PCB. Replace 'Flow' thermistor.
	Slow flash(once every 2 seconds): Indicates a possible fault with the PCB (relay).	Replace PCB.
Is the "BURNER" indicator lit?	YES	Is burner firing? If NO: Refer to ' <b>BURNER NOT OPERATING</b> ' Procedure - Section 12.2 (C).

# 12 Fault Finding

## B. No Hot Water - but Central Heating OK

### First - Set Heating switch to OFF

Is the "DEMAND" indicator lit?	NO	Check programmer is calling for hot water. If no programmer is fitted: Check 'Hot Water' switch is set to 'CONSTANT'.
	NO	Check 'Heating' switch is set to 'TIMED'.
Is the "FLOW SWITCH" indicator lit?	NO	Check hot water tap is open. Check water flow rate is at least 3 ltr/min.
	Cannot achieve 3 ltr/min	Check the mains stop tap open fully. Check cold water isolation valve in boiler is open. Check if the flow restrictor (located in the cold water isolation valve) is clear. If not, clean restrictor or remove from valve. NOTE: No flow restrictor is fitted to the Combi 36e model.
	Is the water pressure OK? Low water pressure = low water flow rate	Check standing water pressure. 2 bar minimum standing pressure required  Check running (dynamic) pressure. 1 bar minimum dynamic pressure required.
	If pressure is OK.	Check for blockage in plate heat exchanger unit. NOTE: In hard water areas scale will be produced that can block the plate heat exchanger if no anti-scale protection has been installed. Refer to Section 5 for further details.
If plate heat exchanger is OK.	Check flow switch is correctly positioned: the arrow (on flow switch body) must point in direction of flow (i.e. towards front of boiler). Check switch is free to operate: Close cold water isolation valve, remove flow switch from pipe work – manually operate switch paddle to check. Remove any debris/blockage from the pipework body or switch paddle. Check for electrical continuity between flow switch terminals when switch is closed. No continuity – replace flow switch. Check for 230V at flow switch terminals. No 230V – check connections at PCB. If still no 230V – replace PCB.	
Is the "FLOW SWITCH" indicator lit?	YES	Flow switch is activated. Continue to the next check.
Is the "DHW PUMP" indicator lit?	NO	Continue to next check.
Is the "DHW PUMP" flashing?	YES Fast or Slow flash	First – set boiler 'On/Off' switch to 'OFF'. Wait 5 seconds. Then set 'On/Off' switch back to 'ON'.
If the "DHW PUMP" indicator Continues flashing.	Fast flash (twice per second): Indicates a possible fault with the 'Store' thermistor.	Check DHW 'Store' thermistor connection to PCB. Replace 'Store' thermistor.
	Slow flash (once every 2 seconds): Indicates a possible fault with the PCB (relay).	Replace PCB.

## B. No Hot Water - but Central Heating OK continued

Is the "DHW PUMP" indicator lit?	YES PCB is supplying voltage to the DHW pump – but pump is not working.	Check electrical connections at the pump. Check for 230V at the pump terminals. Check if CH pump is stuck: Remove pump vent screw and check for Rotation of shaft/impeller. If stuck: Rotate shaft manually to restart. If still not operating; Replace the DHW pump. NOTE: A 6 metre pump must be used.
	YES DHW pump is working but no circulation.	Check both pump valves are open. Check Non-return valve on DHW pump is operational (not sticking). Check there are no air locks in the system. (If removal of air lock is difficult – see additional check list). Check the pump impeller is attached to the shaft.
	YES DHW pump is working and water is circulating.	Hot or warm water should be present at hot tap. If not refer to ' <b>Poor Hot Water</b> ' Check List.
Is the "BURNER" indicator lit?	YES	Is burner firing? If NO: Refer to ' <b>BURNER NOT OPERATING</b> ' Procedure - Section 12.2 (C).

## C. Burner not Operating

### First - Set either Hot Water or Heating to ON

Is the "BURNER" indicator lit?	NO	Refer to ' <b>Initial Checklist</b> ' for guidance.
	NO	Continue to next check.
Is the "BURNER" indicator flashing?	YES Fast or Slow flash.	First – set boiler 'On/Off' switch to 'OFF'. Wait 5 seconds. Then set 'On/Off' switch back to 'ON'.
If the "BURNER" indicator continues flashing.	Slow flash (once every 2 seconds): Indicates a possible fault with the PCB (relay).	Replace PCB.
Is the "BURNER" indicator lit?	YES PCB is supplying voltage to the Burner – but burner is not working.	Check all electrical connections to burner control Box. Check for 230V at L & N terminals in control box. Is Lockout button (on control box) lit? If YES: Press 'Lockout' button to reset burner. If burner does not fire – refer to Section 12.4 Burner Fault Finding.

# 12 Fault Finding

## 12.3 Poor Hot Water Checklist – Always check the basics before changing parts!

Burner	If heat energy input is incorrect: heat energy output will be incorrect. Poor heat input = poor hot water!	Check nozzle is correct size. Check oil pump pressure is correct. Check combustion is correctly set.
DHW Pump	Plate heat exchanger requires water circulation from primary store to operate	Check pump speed setting: it must be maximum. Check pump valves are fully open.
Thermistors	DHW “Store” and CH “Flow” thermistors must detect temperatures correctly	Check both are fully inserted in their pockets.
Water Flow Rate at Hot Tap	Excessive flow rate exceeds heat input from burner Excessive flow rate=poor hot water!	Check flow rate at tap. Combi 21e – 12 ltrs/min maximum Combi 26e – 15 ltrs/min maximum Combi 36e – 18 ltrs/min maximum
Water Pressure	Excessive pressure has a major influence on flow rate.	Check standing and operating water pressure. 2 bar minimum standing pressure required 8 bar maximum standing pressure.  If greater than 8 bar: fit a pressure reducing valve on the cold supply to the boiler.  1 bar minimum dynamic pressure required.
Water Condition	Scale forming in the plate heat exchanger = poor heat transfer in plate = poor hot water temperature.	Check for scale in plate heat exchanger. Replace plate heat exchanger if necessary. In hard water areas some form of anti-scale device or water softener MUST BE FITTED.  NOTE: Faults due to hard water scaling are not covered by the Grant Product warranty.
Thermostatic Blending Valve	Must be correctly set to provide Optimum hot water.	Check if blending valve is scaled up (see ‘ <b>Water Condition</b> ’ section above).  Clean or replace as necessary.



## 12.4 Riello RDB Burner Fault Finding

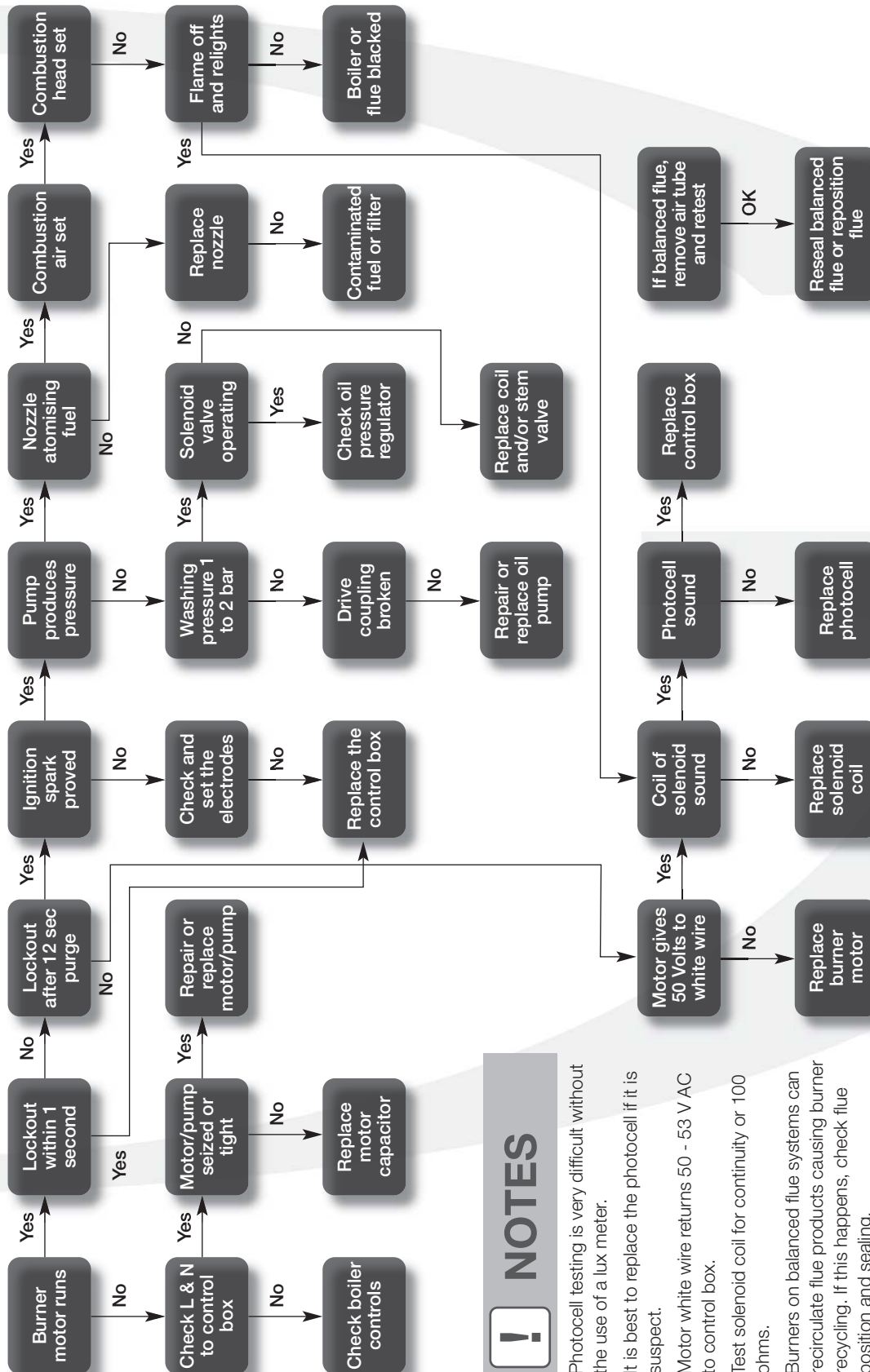

### NOTES

- Photocell testing is very difficult without the use of a lux meter.
- It is best to replace the photocell if it is suspect.
- Motor white wire returns 50 - 53 V AC to control box.
- Test solenoid coil for continuity or 100 ohms.
- Burners on balanced flue systems can recirculate flue products causing burner recycling. If this happens, check flue position and sealing.

# 13 Spare Parts

Figure 13-1 is an exploded view of the Riello RDB burner as used in the Grant VORTEX Pro Combi 21e, 26e and 36e boilers, and the associated parts list follows the figure.

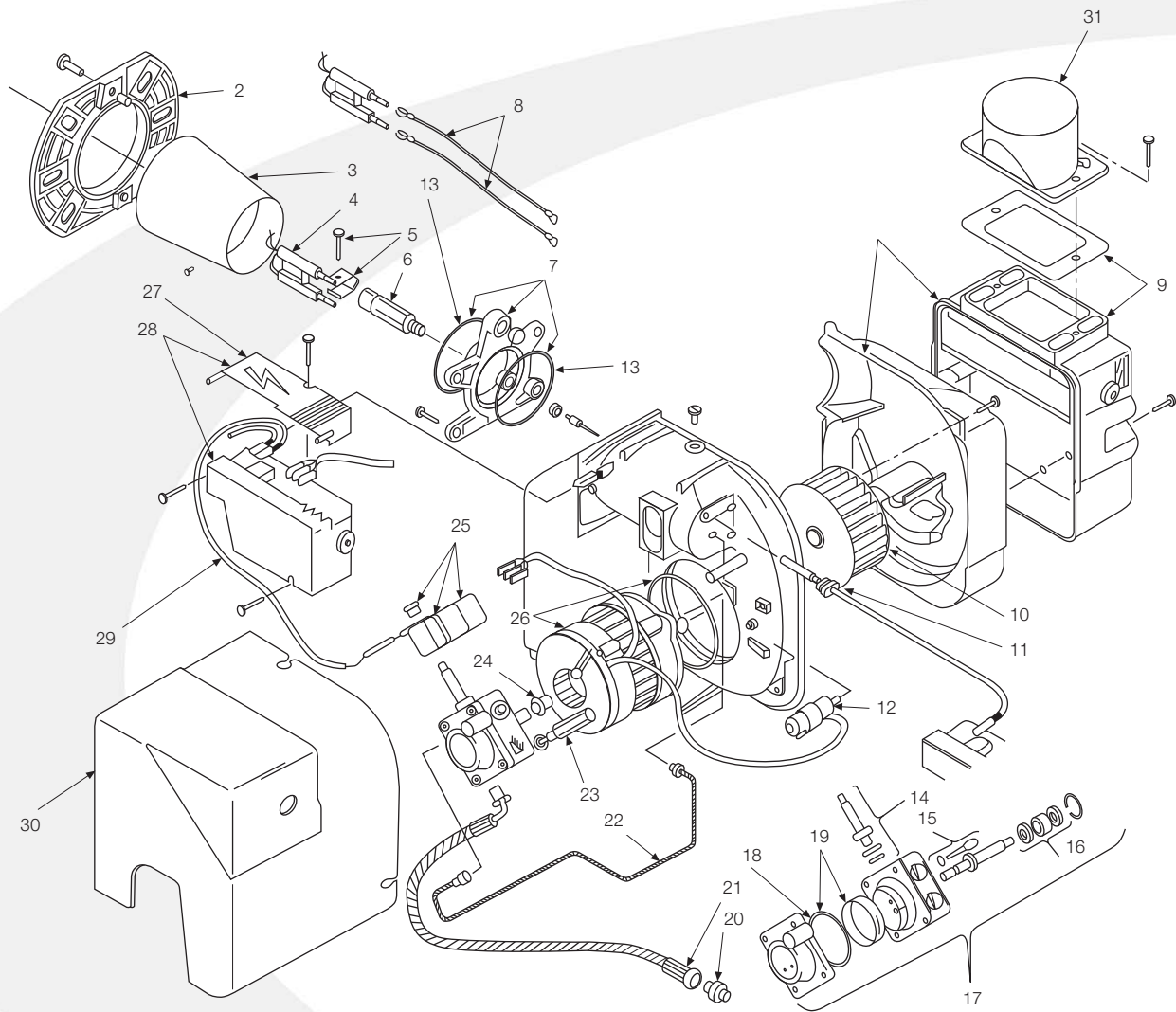

Figure 13-1: Riello RDB burner exploded view

Key No.	Description	Riello Part No.	Grant Part No.	Key No.	Description	Riello Part No.	Grant Part No.
1	Not applicable			15	Regulator	3008651	RBS120
2	Flange 3005786	RBS28		16	Pump seal	3000439	RBS14
3	Combustion head T1 (Combi 21e)	3002507	RBS146	17	Pump	3008654	RBS101
3	Combustion head T2 (Combi 26e)	3002423	RBS147	18	'O' ring	3007162	RBS08
3	Combustion head T5 (Combi 36e)	3002533	RBS150	19	Filter - 'O' ring	3008653	RBS122
4	Electrode assembly	3007513	RBS108	20	Connector	3003602	RBS35
5	Electrode bracket	3006552	RBS29	21	Flexible hose	3007672	RBS36
6	Nozzle holder	3008642	RBS111	22	Tube	3008644	RBS113
7	Collar	3008643	RBS112	23	Pressure gauge connector	3008876	RBS138
8	High voltage lead	3008794	RBS129	24	Drive coupling	3000443	RBS16
9	Air damper assembly	3008647	RBS116	25	Solenoid	3008648	RBS117
10	Fan (Combi 26e)	3005708	RBS39	26	Motor RBS102	3002836	RBS102
10	Fan (Combi 21e/36e)	3005788	RBS151	27	Cover	3008649	RBS118
11	Photocell	3008646	RBS115	28	Control box assembly	3008652	RBS103
12	Capacitor 4.5 $\mu$ F	3002837	RBS149	29	Solenoid lead	3008851	RBS139
13	Seal kit	3008878	RBS140	30	Cover	3008879	RBS141
14	Needle valve	3007582	RBS109	31	Air tube spigot	3062774	RBS143

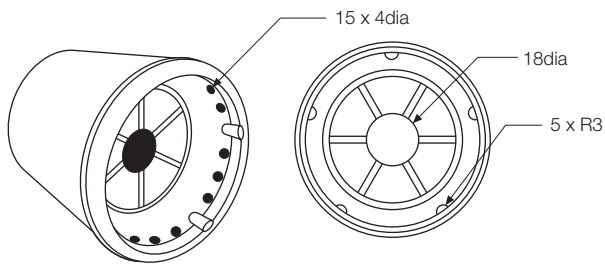

Figure 13-2 T1: Combustion head Vortex Pro Combi 21e

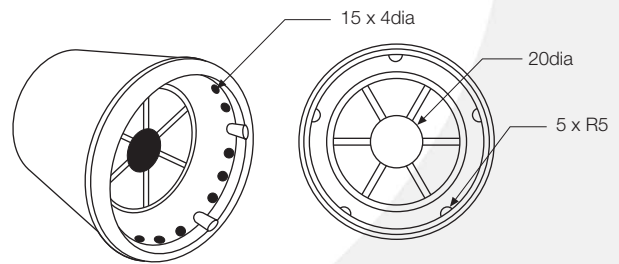

Figure 13-3 T2: Combustion head Vortex Pro Combi 26e

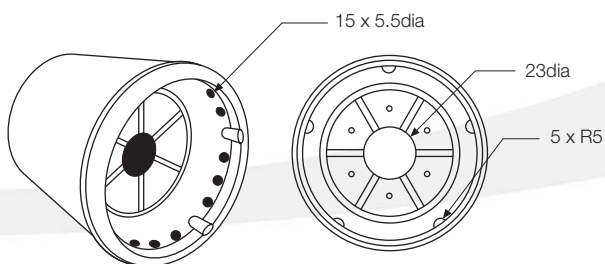

Figure 13-4 T5: Combustion head Vortex Pro Combi 36e

# 14 Health and Safety Information

Under the Consumer Protection Act 1987 and Section 6 of the Health & Safety at Work Act 1974, we are required to provide information on substances hazardous to health (COSHH Regulations 1988).

Adhesives, sealants and paints used in the manufacture of the product are cured and present no known hazards when used in the manner for which they are intended.

The following other materials are present in the product:

## 14.1 Insulation Materials

**Material Types:** Ceramic fibre board, mineral wool.

**Description:** Rigid board, slabs, sleeves, gaskets, ropes.

**Known Hazards:** May cause temporary irritation or rash to skin. High dust levels may irritate eyes and upper respiratory system.

**Precautions:** Avoid unnecessary or rough handling, or harsh abrasion of boards. Normal handling and use of material should not produce high dust levels.

Avoid inhalation, and contact with skin and eyes.

After handling always follow normal good hygiene practices.

**Protection:** Use disposable gloves, face mask and eye protection.

**First Aid:** Eyes - If irritation occurs, wash eyes with copious amounts of water. If symptoms persist, seek immediate medical advice.

Skin - If irritation occurs, wash under running water before washing with soap and water.

Inhalation - Remove to fresh air, drink water to clear throat and blow nose to remove dust/fibres.

Ingestion - Drink plenty of water.

## 14.2 Insulation Materials

**Material Types:** Silicone elastomer.

**Description:** Sealant and adhesive.

**Known Hazards:** Irritation to eyes.

**Precautions:** Avoid inhalation of vapour, contact with eyes and prolonged or repeated contact with skin.

After handling always follow normal good hygiene practices.

**Protection:** Use eye protection. Rubber or plastic gloves should be worn where repeated contact occurs and a face mask worn when working in confined spaces.

**First Aid:** Eyes - Flush eyes with water for 15 minutes. Seek immediate medical attention.

Skin - Wipe off and wash with soap and water.

Inhalation - Remove to fresh air.

## 14.3 Kerosene and Gas Oil Fuels (mineral oils)

**Known Hazards:** The effect of mineral oils on the skin vary according to the duration of exposure and the type of oil.

The lighter fractions remove the protective grease naturally present on the skin, leaving it dry, liable

to crack and more prone to damage by cuts, abrasions and irritant chemicals.

Skin rashes (Oil acne) most often on arms, but also on any part of the body in contact with oil or oily clothing.

Contact with fuel oils can cause dermatitis.

**Precautions:** Avoid as far as possible any skin contact with mineral oil or with clothing contaminated with mineral oil.

The use of a lanolin-based barrier cream is recommended, in conjunction with regular washing with

soap and rinsing with water to ensure all oil is removed from the skin.

Take care to prevent clothing, especially underwear, from becoming contaminated with oil.

Do not put oily rags or tools in pockets, especially trouser pockets.

Have first-aid treatment at once for an injury, however slight.

Do not inhale any vapours from mineral oils.

# 15 EC Declaration of Conformity

We declare that the Grant Vortex range of Oil Boilers equipped with Riello RDB burners approved to EN 267: 1991 satisfy the requirements of the following European Directives:-

1. 89/336/EEC - Electromagnetic Compatibility Directive  
Referred to the generic standards EN 55014: 1993, EN 50082: 1: 1992
2. 73/23/EEC - Electrical Equipment Safety Regulations Directive  
Referred to the generic standard NO: 3260: The Electrical Equipment (Safety) Regulations: 1994
3. 92/42/EEC - Hot Water Boiler Efficiency Directive  
Referred to the generic standard The Boiler (Efficiency) (Amendment) Regulations 1994 (SI 1994/3083).

## In EU Countries

The following information is provided to enable regulatory compliance with the European Union (EU) directives identified and any amendments made to these directives when using electrical or electronic equipment in EU countries.

## Disposal of Electrical and Electronic Equipment

European Union (EU) Directive 2002/96/EC Waste Electrical and Electronic Equipment (WEEE).

Do not dispose of electrical or electronic equipment in landfill sites. In the EU, it is the individual recipient's responsibility to ensure that discarded electrical or electronic materials are collected and recycled according to the requirements of EU environmental law.

## Disposal of Surplus Packaging

European Parliament and Council Directive 94/62/EC Packaging and Packaging Waste

Do not dispose of surplus packaging in landfill sites. In the EU, it is the individual recipient's responsibility to ensure that packaging materials are collected and recycled according to the requirements of EU environmental law.



## In non-EU Countries

In non-EU countries, dispose of electrical and electronic equipment and all surplus packaging in accordance with national and regional regulations.

Complies with EC Low voltage Electromagnetic compatibility and Boiler efficiency Directives.



# 16 Warranty

## 16.1 The Vortex Oil Boiler Warranty

### Dear Customer

You are now the proud owner of a Grant Vortex Pro condensing Combi Boiler from Grant Engineering (UK) Ltd, that has been designed to give years of reliable, trouble free operation.

Grant Engineering (UK) Ltd. guarantees the manufacture of the boiler including all electrical and mechanical components for a period of twelve months from the date of purchase provided the boiler is installed in full accordance with the installation instructions provided. This will be extended to a period of two years if the boiler is registered with Grant UK within thirty days of installation and it is serviced at twelve month intervals. See Terms and Conditions below.

### IMPORTANT

Please register your Grant Vortex Pro Combi boiler with Grant UK within thirty days of installation. To do so visit [www.grantuk.com](http://www.grantuk.com) and follow the links to the 'Householder Zone', where you can register your boiler for a further one year warranty (giving two years from the date of purchase). This does not affect your statutory rights.

### Breakdown during the Manufacturer's Warranty

If your Grant boiler should fail within the first two years, you must contact Grant Engineering (UK) Ltd, who will arrange for the repair under the terms of their Warranty, providing that the boiler has been correctly installed and commissioned, serviced (if older than twelve months) and the fault is not due to tampering, running out of oil, oil contamination, system water contamination, misuse, or the failure of any external components not supplied by Grant UK (e.g. fire valve, motorised valve, etc.). This extended two year warranty only applies if the boiler is registered with Grant UK within thirty days of installation.

### In the first Instance:

Contact your installer or commissioning engineer to ensure that the fault does not lie with the system or any other components, or any incorrect setting of the system controls.

### If a Fault is Found:

Ask your installer to contact Grant Engineering (UK) Ltd Service Department on 01380 736920 who will arrange for a qualified service engineer to attend to the fault.

### Free of Charge Repairs:

During the first two years no charge for parts or labour will be made provided that the boiler has been installed and commissioned correctly in accordance with the manufacturer's instructions, it was registered with Grant UK within thirty days of installation and, for boilers over twelve months old, details of annual maintenance is available.

The following documents must be made available to Grant UK on request:

- Proof of purchase
- CD10 Installation Completion form
- CD11 Commissioning report form
- Service documents (CD11 or equivalent document)

### Chargeable Repairs:

A charge may be made (if necessary following testing of parts at Grant UK) if the cause of the breakdown is due to any of the following:

- Faults caused by the plumbing or heating system, e.g. contamination of parts due to system contamination, debris or trapped air.
- Faults due to incorrectly sized expansion vessel(s) or incorrect vessel charge pressure.
- Faults caused by external electrics and external components.
- The boiler has not been commissioned, or serviced in accordance with the installation and servicing manual.
- Problems caused by lack of oil or faults with the oil supply system.
- The flue system has been incorrectly fitted or does not meet installation requirements.

- The boiler has been installed for over two years and no extended warranty cover has been taken.

Note: The nozzle supplied with the boiler is only covered for the period up to the time of the first service (twelve months).

### Remember - before you contact Grant:

Ensure the boiler has been commissioned and serviced in accordance with the Installation and servicing manual.

Ensure there is oil to supply the burner.

Ensure the problem is not being caused by the heating system or its controls.

Consult the boiler handbook for guidance.



## NOTE

**Do not wait until the fuel supply runs out before you order some more. Sludge in the bottom of the tank may be drawn into the fuel lines. It is recommended that the boiler is switched off when the new supply is delivered and that the fuel is allowed to settle for an hour before restarting the boiler.**

### Terms of Manufacturer's Guarantee

1. The Company shall mean Grant Engineering (UK) Limited.
2. The boiler is guaranteed for two years from the date of purchase providing that after twelve months the annual service has been completed and the boiler registered with the Company within thirty days of the installation date. Any work undertaken must be authorised by the Company and carried out by an approved service agent.
3. The shell (heat exchanger) of the oil boiler supplied by the Company is covered by a five year parts only guarantee from the date of purchase subject to correct operation of the boiler. Proof of annual maintenance must be provided.
4. This guarantee does not cover breakdowns caused by incorrect installation, neglect, misuse, accident or failure to operate the boiler in accordance with the manufacturer's instructions.
5. The boiler is registered with the Company within thirty days of installation. Failure to do so does not affect your statutory rights.
6. This guarantee is not transferable unless sanctioned by the Company.
7. The Company will endeavour to provide prompt service in the unlikely event of a problem occurring, but cannot be held responsible for any consequences of delay however caused.
8. This guarantee applies to Grant boilers installed on the UK mainland, Isle of Man and Channel Islands only. Provision of in-warranty cover elsewhere in the UK is subject to agreement with the Company.
9. All claims under this guarantee must be made to the Company prior to any work being undertaken. Invoices for call out/repair work by any third party will not be accepted unless previously authorised by the Company.
10. Proof of purchase and date of installation, commissioning and service documents must be provided on request.
11. If a replacement boiler is supplied under the warranty (due to a manufacturing fault) the product warranty continues from the installation date of the original boiler, and not from the installation date of the replacement.

### Hard Water Advice

If you live in a hard water area, protection against scaling must be given to the domestic hot water heat exchanger of your combination boiler. You should fit an appropriate scale inhibitor or water softener as **any breakdown caused by water scaling is not covered by either the manufacturer's guarantee or insurance.** Ask your installer for advice.

### 16.2 Extended Warranty

For further peace of mind Grant Engineering (UK) Ltd offer the option to insure all the components of your Grant Vortex Pro Combi boiler for a further three years, following on from the two year product warranty period. For a single premium payment (inclusive of Insurance Premium tax) you get five years of protection against breakdown costs. At the end of this period you will have the opportunity to continue this cover on an annual basis.

To access full details and an application form for this extended cover, first visit [www.grantuk.com](http://www.grantuk.com).

Follow the links to the 'Householder Zone', register your Grant Vortex pro boiler for a further one year product warranty (giving two years from the date of purchase), and then download the extended warranty details and application form.

Please note that this special offer is only available if the application form is submitted to Bluefin Insurance Services Ltd. within three months of the installation date.

# Notes





## To Re-pressurise the System by adding Water



**WARNING**

**Add water to the system only when it is cold and the boiler is switched off. Do not overfill.**

The procedure is as follows:

1. Ensure the flexible filling loop is connected and that the shut off valve connecting it to the boiler is open and the double check valve at the front is closed. A valve is open when the operating lever is in line with the valve, and closed when it is at right angles to it.

2. Gradually open the double check valve on the front of the filling loop until the water is heard to flow.
3. Vent each radiator in turn, starting with the lowest one in the system, to remove air.

4. Continue to fill the system until the pressure gauge indicates the required pressure between 0.5 and 1.0 bar. Close the fill point valve.

5. Close the valves either side of the filling loop and disconnect the loop.

## General Notes and Care of your System

**Boiler controls** - Refer to the section **Boiler controls**.

**Pressure switch** - If the heating system water pressure falls below 0.2 bar the boiler pressure cut-out switch will activate and the red 'LOW PRESSURE' indicator on the control panel (see Figure 2) will flash. The system must be recharged to between 0.5 to 1 bar. If the heating system loses pressure on a regular basis then contact your installer to investigate the cause.

**Burner Lock-out reset button** - If there is a burner malfunction, a built-in safety circuit switches the burner off and the 'Lock-out' reset button on the burner will light. Usually such malfunctions are short lived and pressing the reset button will restore normal operation.

The reset button should not be pressed more than twice in attempting to start the burner.

If the burner continually goes to 'Lock-out' a fault exists or the fuel supply is low. If you have checked that you have sufficient fuel, you will need to call your Service engineer.

**Overheat thermostat** - Your boiler is fitted with a safety overheat thermostat which will automatically switch off the boiler in the case of a control malfunction causing overheating. The red 'OVERHEAT' indicator on the control panel (see Figure 2) will flash indicating the overheat thermostat has operated.

If your boiler goes off and you try to light it but nothing happens and the 'Lock-out' reset button on the burner is not lit, the overheat thermostat has probably operated. The boiler will not light until the thermostat is reset. To reset, unscrew the small plastic cap (see Figure 2), and press the button and the 'OVERHEAT' indicator should go off. Replace the plastic cap.



**NOTE**

**You may have to wait for the boiler to cool down before the button will reset. If this condition repeats, contact your Service engineer.**

Check the system pressure and re-pressurise as necessary before attempting to reset the overheat thermostat. Refer to Sealed central heating system in these instructions for details on re-pressurising the system.

**Ventilation** - Always ensure that the boiler has adequate ventilation. Any ventilation openings in the boiler casing must not be obstructed. Periodically check that they are clear. Do not attempt to 'box in' the boiler or build a compartment around it. Do not place any combustible material on or around the boiler.

**Flue terminal** - The flue terminal must not be obstructed or damaged. In severe conditions check that the terminal does not become blocked with snow. Do not place any combustible material on or around the flue terminal.

**Frost Protection** - Your boiler is fitted with a pre-set internal frost protection thermostat. Should either the air temperature around the boiler, or the water temperature within the boiler, fall to below 5°C then this thermostat will be activated. The boiler will then operate briefly to prevent it from freezing. Your boiler may also be fitted with a remote frost protection thermostat; check with your installer. If you are intending to be away for a long period, the boiler and system should be drained. Contact your Service engineer for draining and filling the system.

**Cleaning and servicing** - Lightly wipe over the case with a damp cloth and a little detergent. Do not use abrasive pads or cleaners. You should have your boiler serviced at least once a year to ensure safe and efficient operation. Contact your Service engineer for further details.

**Failure of electricity supply** - If the electricity supply fails, the boiler will not operate. It should relight automatically when the supply is restored.



**NOTE**

The time and on/off settings on a 7-day or 24-hour timer or a 2-channel programmer may need to be reset after a power failure. The Grant Programmable Room Thermostat and Wireless Programmable Room Thermostat are battery powered and will be unaffected by a power failure.

## Electricity Supply

The boiler requires a 230/240 V - 50 Hz supply. It must be protected by a 5 Amp fuse.



**WARNING**

The Vortex boiler contains electrical switching equipment and must be earthed.

## Points to Check if the Boiler Fails to Light

Perform the following checks if your boiler fails to light:

1. Ensure that a fuse has not blown or that the electricity supply has not failed.
2. Check that the boiler On/Off switch is set to ON and that the POWER indicator on the control panel is lit.
3. Check that the timer or programmer is working and is in an 'on' period.
4. Check that all thermostats are set to the desired setting and are 'calling' for heat.
5. Check the DEMAND indicator on the control panel is lit.
6. Check if the burner 'Lock-out' reset button (on the front face of the burner) is lit. See Figure 1.
7. If it is, press in the button to start the burner. If the burner fails to light and goes to 'Lock-out' again, check that you have sufficient fuel in the storage tank and the fuel supply valves are open.
8. Check that remote fire valve has not 'tripped'. Reset if necessary.
9. Check to see if the overheat thermostat has operated. See Overheat thermostat under General notes and care of your system.
10. Check the heating system water pressure. If it falls below 0.2 bar the boiler low pressure cut-out will be activated, cutting power to the burner, and the red 'LOW PRESSURE' indicator on the control panel (see Figure 2) will flash. The system must be re-charged to between 0.5 and 1 bar. If the heating system loses pressure on a regular basis then contact your installer to investigate the cause.

If the burner still fails to light after carrying out these checks then a fault exists. Switch off the electricity supply to the boiler and contact your service engineer.

## Domestic Hot Water System

The boiler will supply domestic hot water whenever a hot tap is opened, provided the boiler On/Off switch is set to ON. If a 2-channel programmer is fitted, the Hot water setting on the programmer must be 'on' for the boiler to provide continuous hot water.

### 'Night time' Hot Water Function

This is a feature built in to your boiler allowing a limited amount of hot water to be drawn off during periods when either the hot water programmer channel is 'off' (for example, during the night). When a hot tap is opened during this period, the flow switch activates the hot water store pump and the incoming mains cold water is heated using whatever heat is present in the primary heat in the store will gradually be used up and the hot water temperature will reduce with time.

If a 2-channel programmer is fitted, the Hot water setting on the programmer must be 'on' for the boiler to provide continuous hot water when the Hot Water switch is set to TIMED.

## NOTE

**The flow of water from the taps (hot or cold) depends on the mains pressure, and in some homes it may not be possible to use more than one tap at a time.**

## Sealed Central Heating System

The boiler operates on a sealed heating system. Your installer will have pressurised the system and set the white pointer on the pressure gauge (see Figure 2) to indicate a system pressure (when cold) of usually between 0.5 and 1.0 bar. **Do not** adjust this pointer.

The white pointer indicates the actual system pressure which will increase slightly when the boiler is operating. If the white pointer falls below the red pointer (when the boiler is switched off and cold), you should contact your installer to check the heating system for leaks.

## NOTE

**Your sealed system may incorporate a 'Top-up' vessel. Advice on how to use this should be obtained from your installer.**

The boiler is fitted with a safety (or pressure relief) valve to automatically release excess pressure from the system. If the water or steam is emitted from the end of the safety valve discharge pipe, switch off the boiler and contact your installer or Service Engineer.

The Expansion vessel air charge must be checked annually. Failure to maintain an adequate air charge in the vessel may invalidate the warranty.

**Lighting your Boiler**

- Before lighting your boiler, ensure that :  
 • There is sufficient fuel in the supply tank  
 • All fuel supply valves are open.  
 • The water supply is on  
 • The electricity supply to the boiler is off  
 • The Boiler On/Off switch is set to OFF  
 • The white pointer on the pressure gauge is not below the red pointer  
 • The room thermostat is at the desired setting  
 • The timer or programmer is correctly set

Switch on the electricity supply to the boiler.  
 Set the On/Off switch to ON. Refer to Figure 2.

The boiler will light automatically to heat the water stored in the boiler. If the programmer or Timer is set to a heating 'on' period and the room thermostat is 'calling' for heat, the boiler will continue to run to provide central heating, after the store reaches temperature.  
 Once the store has reached temperature, if a hot tap is opened the boiler will supply hot water.

**Turning off your Boiler**

For short periods - Set the On/Off switch to OFF. Refer to Figure 2.  
 To re-start the boiler, simply set the switch to ON.

For long periods - Set the On/Off switch to OFF and switch of the electricity supply to the boiler. If required, the fuel supply valve may be closed and the water and electrical supplies turned off at the mains. To re-start the boiler, refer to the full lighting instructions above.

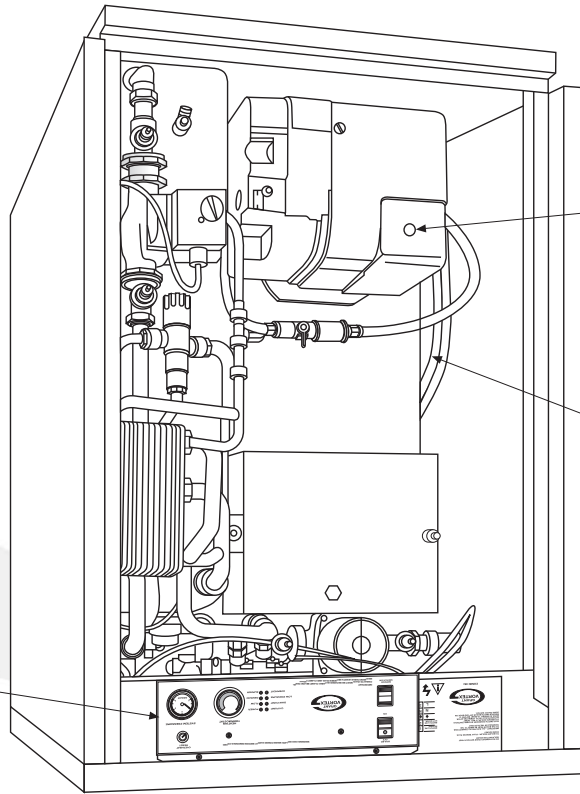

Expansion vessel (in models, this is mounted on the front of the boiler)  
 Burner lock-out button

**Figure 1:** Vortex Pro External Combi 21e boiler with front panel removed showing position of control panel

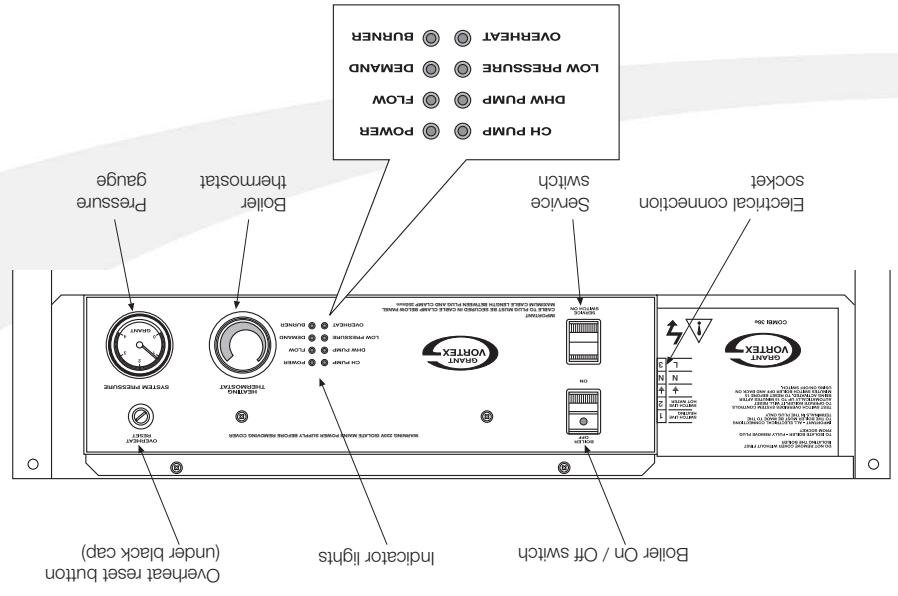

**Figure 2:** Vortex Pro External Combi e boiler control panel

- CH PUMP ● POWER
- DHW PUMP ● FLOW
- LOW PRESSURE ● DEMAND
- OVERHEAT ● BURNER

Boiler On / Off switch  
 Indicator lights  
 Service switch  
 Electrical connection socket  
 Pressure gauge  
 Thermostat  
 Under black cap)  
 Overheat reset button

# User Instructions

## Introduction

This manual is intended to guide users of the GRANT VORTEX Pro Combi External Condensing Oil Boiler range to help you get the most from your boiler system. A separate manual is supplied for use by installers and maintenance engineers, and is printed inverted at the end of this manual.

The following special text formats are used in this manual for the purposes listed below:

## WARNING



Warning of possible human injury as a consequence of not following the instructions in the warning.

## NOTE



Note text. Used for emphasis or information not directly concerned with the surrounding text but of importance to the reader.

## About your Boiler

Your Grant Vortex Pro Combi boiler is fully automatic and when the boiler On/off switch is set to ON, will provide domestic hot water at mains pressure on demand and central heating when the hot water and heating system controls call for it.

Your boiler may be fitted with one of the following control options, located in a convenient position remote from the boiler:

- Option A Programmable room thermostat only.
- Option B Remote timer and room thermostat.
- Option C Remote two-channel programmer and room thermostat.
- Option D Remote 'wireless' two-channel programmable room thermostat (with boiler mounted 'plug-in' receiver unit).

Whatever type of control is connected to your boiler, it will allow you to set the operating times of your central heating.

In the case of options A and B -

domestic hot water is available

continuously, providing the boiler is switched on, irrespective of the heating control settings.

In the case of options C and D - you

can set the operating times for both

heating and hot water using the heating

and hot water settings respectively on

the programmer, or wireless two-

channel programmable room

thermostat.

## NOTE



The boiler will produce a limited

amount of hot water during the 'off'

Hot Water periods set on the

programmer. Refer to 'Night time' hot

water operation - Section 'Night time' hot water function.

## Boiler Controls

To access the Outdoor Combi controls, remove the front panel by turning the handle at the bottom and pull it forward

at the bottom.

**Boiler On/Off switch** - This switches

the boiler on and off. The boiler On/Off

switch incorporates a 'mains on' neon;

see Figure 2, which lights when the

boiler is switched on. Please note that

the 'mains on' neon does not

necessarily indicate that the burner is

firing.

## NOTE



When the On/Off switch is set to ON the POWER indicator on the control

panel will light.

The boiler will not supply central

heating or domestic hot water if this

switch is set to OFF, and also the

built in frost thermostat will not

operate.

## About your Fuel

Grant Vortex Pro Combi boilers only

operate on Class C2 Kerosene to

BS2869:1998. You should always quote

the type of fuel you require when

ordering from your supplier.

Do not wait until the fuel runs out before you order some more. Sludge in the

bottom of the tank may be drawn into

the fuel lines. If it is possible, switch off

the boiler when the new supply is

delivered and leave the fuel to settle for

an hour before restarting the boiler.

Figure 1 shows the components in the Vortex Pro Combi e external boilers and the position of the control panel. Figure 2 shows the details of the control panel.

The temperature of the water leaving

the boiler to the radiators can be

increased by turning the boiler (heating)

thermostat clockwise.

to the taps.

Operation of this control does not affect the temperature of the hot water flowing

the temperature of the water leaving the boiler to the central heating system.

Boiler (heating) thermostat - Controls

the boiler.

**Boiler indicator lights** - These 8 red lights indicate the operating situation of

the boiler.

When 15 minutes have elapsed since it

automatically revert to normal operation cannot be left set to ON. The boiler will

'momentary' or non-latching switch that servicing purposes. This is a

programmer) to operate the boiler for

controls (timer, room thermostat or

override the remote heating/hot water

the Service Engineer to temporarily

Service switch - This switch enables

# Contents

Introduction	4
About your Boiler	4
Boiler Controls	4
About your Fuel	4
Lighting your Boiler	5
Turning off your Boiler	5
Points to Check if the Boiler Fails to Light	6
Domestic Hot Water System	6
'Night time' Hot Water Function	6
Sealed Central Heating System	6
To Re-pressurise the System by adding Water	7
General Notes and Care of your System	7
Electricity Supply	7



**For use with Kerosene\* only.****After installing the boiler leave these instructions with the User.**

This appliance is deemed a controlled service and specific regional statutory requirements may be applicable.

engineer.

It is recommended that the boiler should be regularly serviced, at least once a year, and the details entered in the Boiler Handbook by the service

**Service Log****\*Operation on Bio-fuel**

All Grant Vortex Pro condensing boilers, manufactured since May 2011, are suitable for operation on both standard kerosene (Class C2 to BS2869) and also bio-kerosene – up to a 30% blend (B30K).

All burner settings and nozzle sizes (as detailed in Section 2.3 of this manual) are correct for both standard kerosene and bio-kerosene (B30K).

In order to operate this boiler on bio-kerosene it will be necessary to take the following actions:

a) Use a bio-kerosene (B30K) compatible flexible oil line in place of the oil line supplied with this boiler.

b) Have your oil storage tank and oil supply line (including all pipework, sight gauges, filters, isolating valves, fire valves, de-aeration devices, etc.) checked for their compatibility with bio-kerosene (B30K).

Where necessary some, or all, of these items may have to be replaced with a bio-kerosene compatible alternative.

c) Check the suitability of the flue system with Grant UK.

d) Use only bio-kerosene (B30K) that conforms to OPS24.

**IMPORTANT**

Under no circumstances should the boiler be used with bio-kerosene without the above actions being taken first.

**GRANT ENGINEERING (UK) LIMITED**

Hopton House, Hopton Industrial Estate, Devizes, Wiltshire SN10 2EU  
Tel: 01380 736920 Fax: 01380 736991

Email: sales@grantuk.com www.grantuk.com

This manual is accurate at the date of printing but will be superseded and should be disregarded if specifications and/or appearances are changed in the interests of continued product improvement.  
All goods sold are subject to our official Conditions of Sale, a copy of which may be obtained on application.  
© Grant Engineering (UK) Limited 2012. No part of this manual may be reproduced by any means without prior written consent.

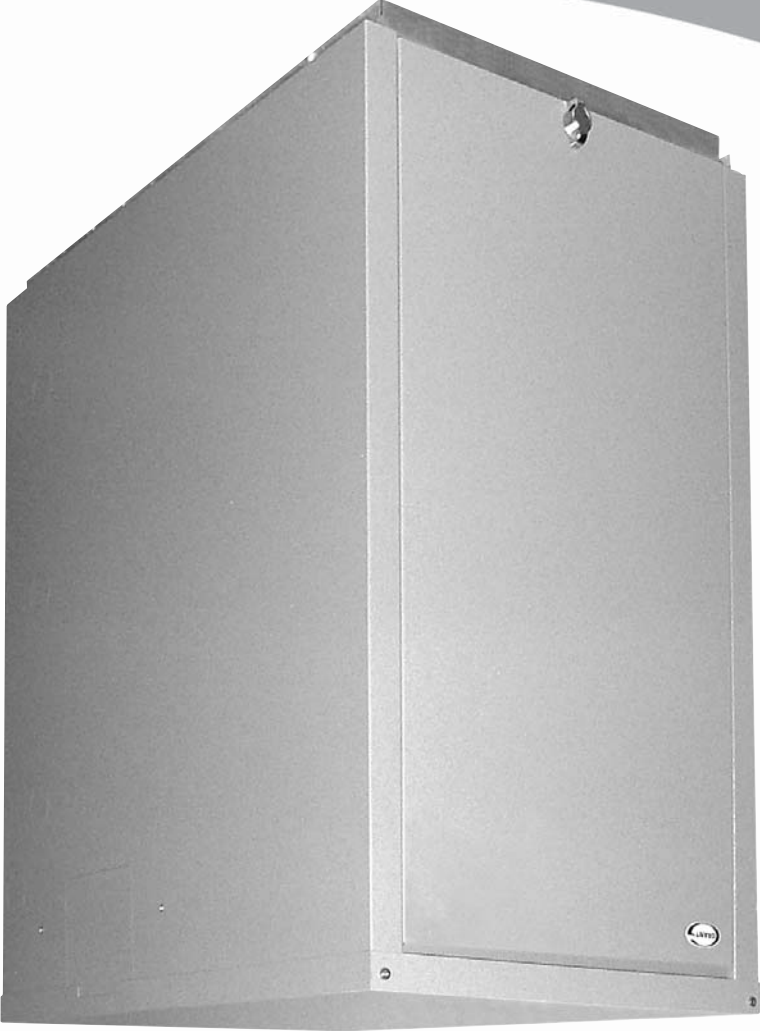

# User Instructions

**Grant VORTEX Pro External Combi**  
Combi 21e, Combi 26e, and Combi 36e Condensing Oil Boiler Range