

# Grant Vortex oil range

Internal and external oil-fired condensing boilers  
with outputs from 12kW to 70kW



Award winning range • 39 different models • Outputs from 12-70kW • Internal, external and boiler house ranges with floor standing and wall hung options • 89.5 - 93.3% Gross SAP2009 annual efficiency • Whisper quiet operation • Five-year heat exchanger guarantee



# Grant profile

At Grant we have been designing and manufacturing reliable and easy to install heating products for over 35 years. From award winning oil-fired condensing boilers to the latest renewable technologies, our heating systems have a reputation for quality that is second to none.

We combine precision engineering, innovation, performance and value for money to produce sustainable heating solutions that are trusted by both installers and householders.



## Quality design

There is never a compromise on quality. We design all of our products so that you can be sure that the durability and efficiency are sector leading. We continually develop new technologies and use only the best materials to ensure our products exceed all performance and environmental standards.

Our belief in simple solutions ensures that, while our technology is sophisticated, our products are low maintenance and easy to install. For a high quality, reliable and sustainable heating system, trust in Grant.

## Heating responsibly

Grant manufacture heating systems that respond to the challenges of rising fuel costs whilst protecting our environment. Environmental responsibility is central to all we do and we continue to develop and innovate to produce even more efficient products that make best use of our natural resources.

We are passionate about developing sustainable, high-performance and affordable alternatives for heating homes into the future.

## Our guarantee

The Grant label is a guarantee of reliability, quality and value. We put our customers first and our independence ensures that we can monitor our standards and processes to deliver the very best quality and service.

That's why, when you order your system from a Grant stockist, you can be sure of a tailored service and excellent aftersales support.

# Oil condensing technology



## What is a condensing boiler?

Condensing boilers are designed to capture heat normally lost through the flue system during the combustion process.

Unlike traditional oil-fired boilers the Grant Vortex condensing boiler has a built-in stainless steel heat exchanger incorporating our unique turbulator baffle system which cools the gases to a point where the latent heat, normally lost to the atmosphere through the flue, can be usefully extracted. The additional energy recovered enables the boiler to operate continuously at much higher efficiency levels, resulting in lower heating and hot water running costs.

## The benefits of Grant Vortex

While older oil-fired boilers operate with energy efficiency levels as low as 65%, modern boilers operate with much higher efficiency. The Grant Vortex range has the highest energy efficiency rating in the UK which not only significantly lowers fuel bills but also considerably reduces greenhouse gas emissions and lessens the environmental impact of domestic hot water and heating systems.

All Grant Vortex boilers are easy to install and can either be connected to a conventional 'stainless steel' flue or one of Grant's EZ-Fit flue options using an existing chimney.



## Award winning technology

Grant has become synonymous with highly efficient oil-fired central heating appliances which help thousands of homeowners to reduce their annual fuel bills. Our 'Multi Pass' boiler achieves efficiency levels far in excess of any UK or European Standards while our Vortex oil-fired condensing boilers top the Government SEBUK Efficiency Database and are the market leading product in this sector.

We have received numerous prestigious and high profile awards in recognition of our innovative product design, high quality engineering and exceptional training.

- Product of the Year 2008 (Grant Vortex range) H&V News Awards for Excellence
- Which? Best Buy Accreditation 2008 (Grant Vortex Combi Pro 26)
- Training Initiative of the Year 2004 H&V News Awards for Excellence
- OFTEC Training Centre of the Year 2012

Trusted by the trade and appreciated by our customers, the Grant Vortex range provides high efficiency, reduced fuel costs and unparalleled customer satisfaction.

# Grant Vortex **Eco Utility** range

## Introduction

The Grant Vortex Eco Utility range was launched as a direct response to customer demand for a competitively priced condensing boiler.

The Eco models incorporate the latest version of the Grant Vortex stainless steel heat exchanger. Outputs range between 15kW and 35kW (50-120,000Btu/h) with SAP 2009 gross seasonal efficiencies of 90.3 - 90.8% gross.

As you would expect from a product with this pedigree, Grant Vortex Eco Utility boilers are exceptionally quiet in operation and feature the latest Riello burner technology. The boilers also have a simplified casing, control panel and pipework arrangement, making them the ideal choice for utility room installations.

All standard Eco Utility boilers are designed to allow the burner and combustion chambers to be serviced from the front, however, models fitted with a sealed system kit require top service access.

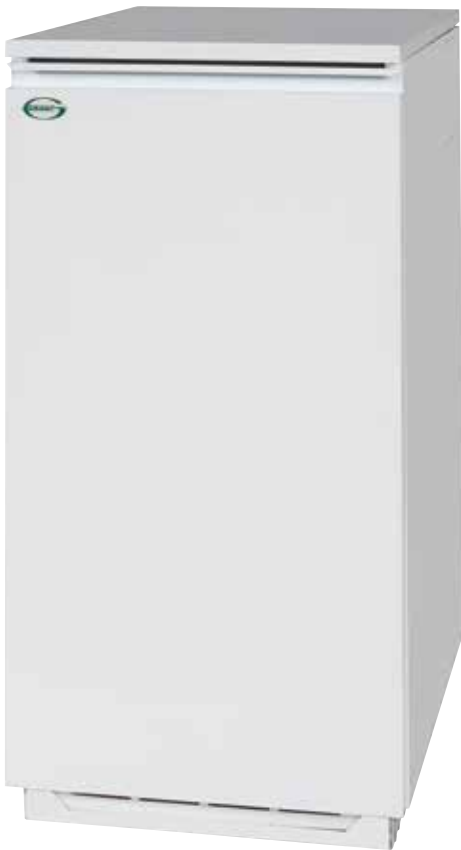

## Dimensions (mm)

### Grant Vortex Eco Utility 15-21 and 21-26

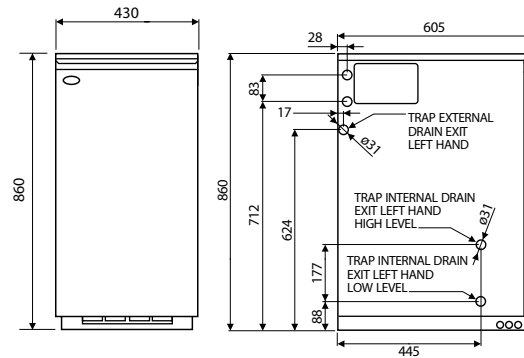

### Grant Vortex Eco Utility 26-35

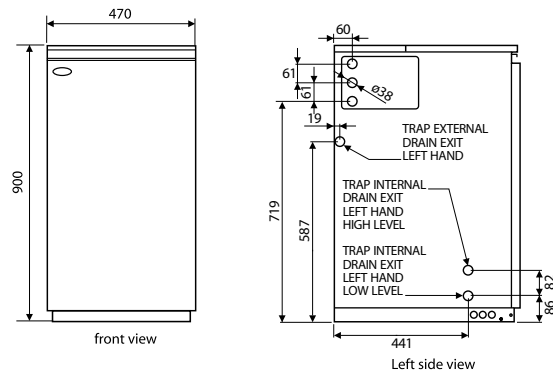

## Condensate removal

The condensate trap is now factory fitted within the white case on Grant Vortex Eco Utility boilers, but can also be positioned externally if preferred.

## Flueing

Utility models are compatible with all of Grant's EZ-Fit flue options and capable of being flued from the top, rear, left or right hand sides of the appliance.

## Sealed system kits

Grant Vortex Eco Utility models can also be converted to sealed system operation, by adding a sealed system kit (Product code: VTXECOSSKIT35). This optional pack fits all models and can be neatly housed within the boiler enclosure. It includes a filling loop, expansion vessel, pressure gauge and circulating pump.

## Grant Vortex Eco Utility models

VTXECO1521 / VTXECO2126 / VTXECO2635

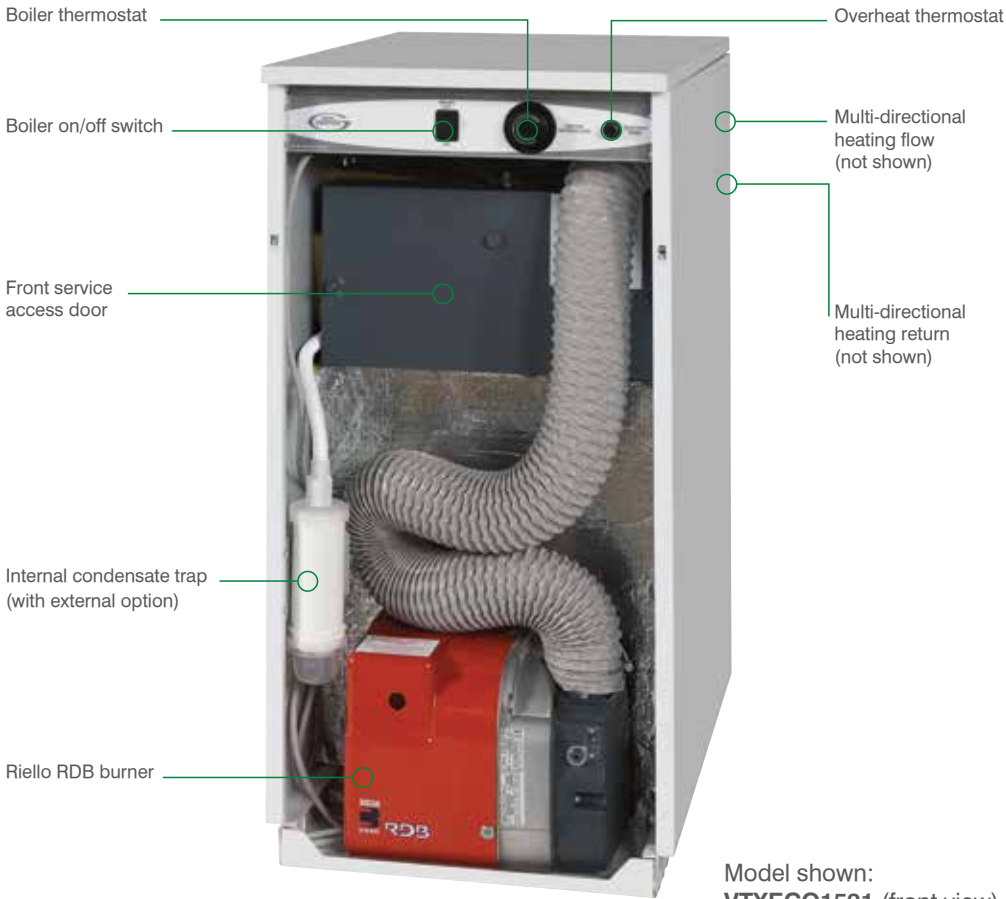

Model shown: VTXECO1521 (front view)



### Technical specifications

Model	Eco Utility Models		
	15-21	21-26	26-35
Output kW	15 to 21	21 to 26	26 to 35
Output Btu/h	50-70,000	70-90,000	90-120,000
Flow connection	22mm	22mm	22mm
Return connection	22mm	22mm	22mm
Cold water in (system kit)	15mm	15mm	15mm
Pressure relief (system kit)	15mm	15mm	15mm
Weight (dry)	112kg	112kg	129kg
Condensate pipe	21.5mm OD plastic overflow pipe		

**Note 1:** The boiler flow and return connections exit the casing on the left or right hand side.  
**Note 2:** Grant Vortex Eco Utility boilers are suitable for fully pumped systems only.

### Vortex Eco wall-mounted programmer options



Optional Grant ES Kit, wall-mounted twin-channel programmer.



Optional Grant RS Kit wall-mounted programmable room thermostat.

# Grant Vortex **Eco External** range

## Introduction

Grant developed the first oil-fired external boiler in 1986 and although the concept was new to the oil market, it quickly became a popular addition to the range. Today, as around one in four oil boiler installations are external, Grant have expanded the number of options available with the launch of three competitively priced Eco External modules. The models have outputs between 15kW and 35kW (50-120,000Btu/h) and SAP 2009 gross seasonal efficiencies of 90.3 - 90.8% gross.

## External finish

This high efficiency Eco External range has some unique features including multi-directional flueing options, high quality external powder coated paint finish, built-in boiler frost protection, mains isolating switch and a test switch.



## Dimensions (mm)

### Grant Vortex Eco External 15-21, 21-26, 26-35

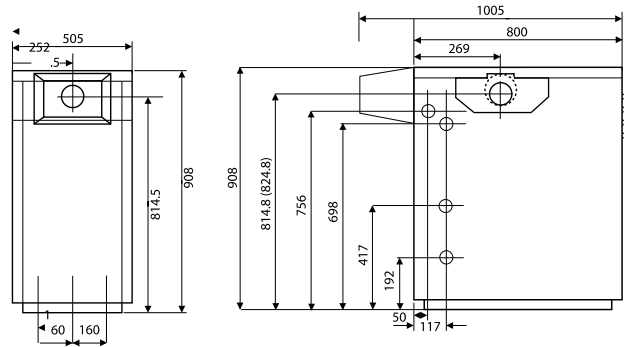

## Sealed system kits

Eco External boilers can be converted to sealed system operation by purchasing a pre-assembled kit from Grant UK (Product code: VTXECOSSKIT35). The sealed system kit includes an expansion vessel, automatic air vent, pressure relief valve and circulating pump. A filling loop and pressure gauge are also supplied as part of the kit. These can be fitted within the module casing, or ideally in a convenient site within the building, located between the cold main and central heating return.



Model shown: Grant Vortex Eco External module

## Grant Vortex Eco External modules

VTXOMECO1521 / VTXOMECO2126 / VTXOMECO2635

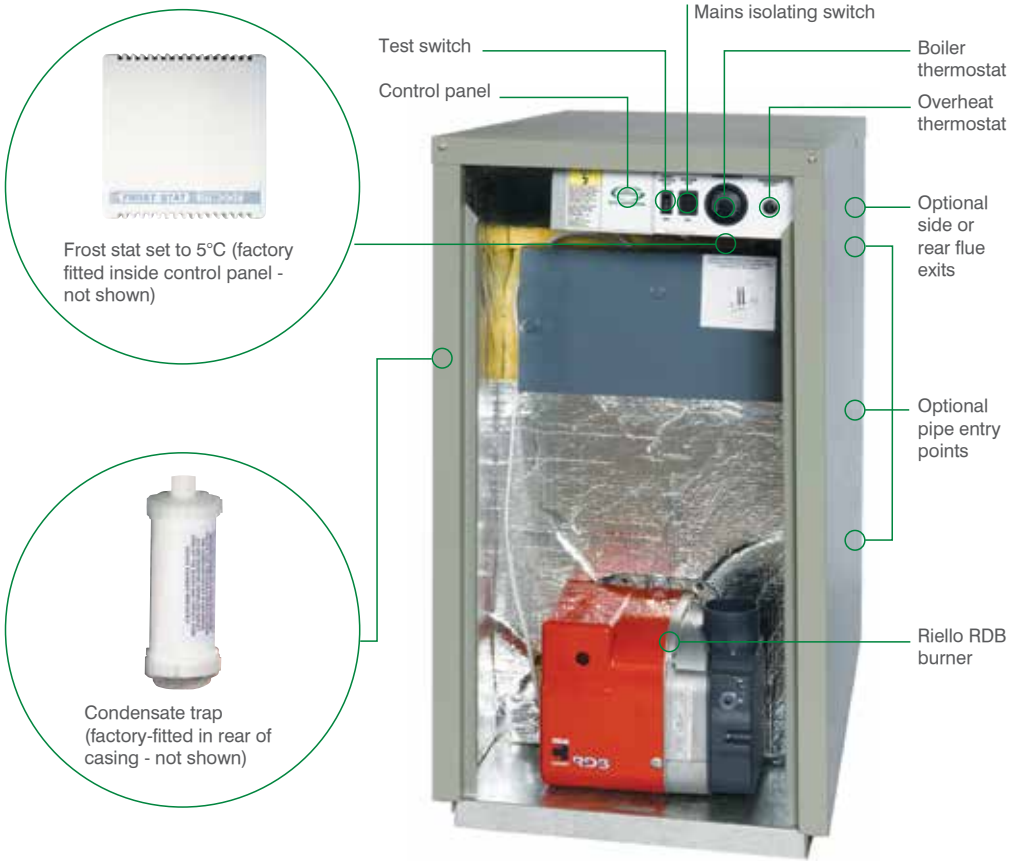

Model shown: VTXOMECO1521 (front view)



Technical specifications			
Model	Eco External modules		
	15-21	21-26	26-35
Output kW	15 to 21	21 to 26	26 to 35
Output Btu/h	50-70,000	70-90,000	90-120,000
Flow connection	22mm	22mm	22mm
Return connection	22mm	22mm	22mm
Cold water in (system kit)	15mm	15mm	15mm
Pressure relief (system kit)	15mm	15mm	15mm
Weight (dry)	127kg	117kg	143kg
Condensate pipe	21.5mm OD plastic overflow pipe		

**Note 1:** All boiler connections can be positioned to the left or right of the appliance.  
**Note 2:** Grant Vortex Eco External modules are suitable for fully pumped systems only.

### Vortex Eco wall-mounted programmer options



Optional Grant ES Kit, wall-mounted twin-channel programmer.



Optional Grant RS Kit wall-mounted programmable room thermostat.

# Grant Vortex **Eco Wall Hung** range

## Introduction

Grant's wall hung oil-fired boiler range comprises four internal and four external models.

Available in outputs ranging from 12-21kW, in both sealed system and open-vented system variants, these new appliances are pre plumbed and encompass Grant's patented Vortex stainless steel heat exchanger and turbulator baffle system.

All internal models require a separate flue kit (not supplied with the boiler) and are compatible with all Grant EZ-Fit low level, high level and vertical flue systems, so now almost any installation situation can be catered for.

## Unique external modules

All Grant Vortex Eco Wall Hung external models come complete with a factory fitted flue, high quality external powder coated paint finish, built-in boiler frost protection, mains isolating switch and a test switch.

## Sealed system models

Grant Vortex Eco Wall Hung boilers are also available in sealed system versions. These include a factory fitted expansion vessel, filling loop, pressure gauge, automatic air vent, pressure relief valve and circulating pump, enabling boilers to be installed without the need for a feed and expansion tank in the loft.



## Dimensions (mm)

### Grant Vortex Eco Wall Hung internal 12-16, 16-21

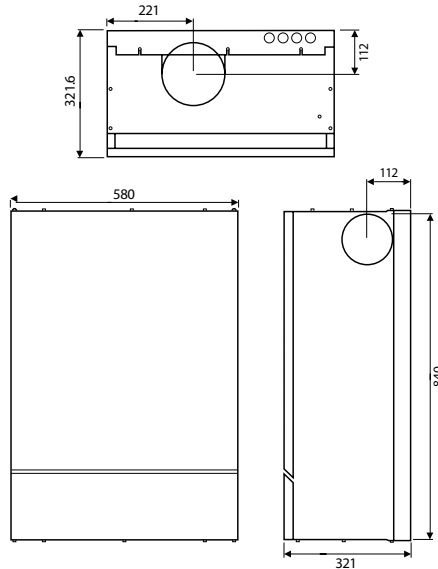

### Grant Vortex Eco Wall Hung external 12-16, 16-21

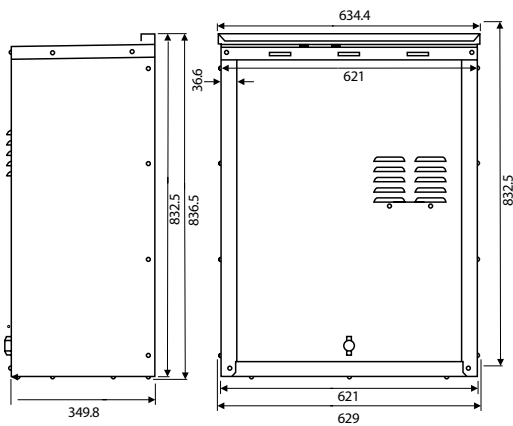



## Grant Vortex Eco Wall Hung internal/ internal system models

VTXWH1216 / VTXWH1621 / VTXSWH1216 / VTXSWH1621

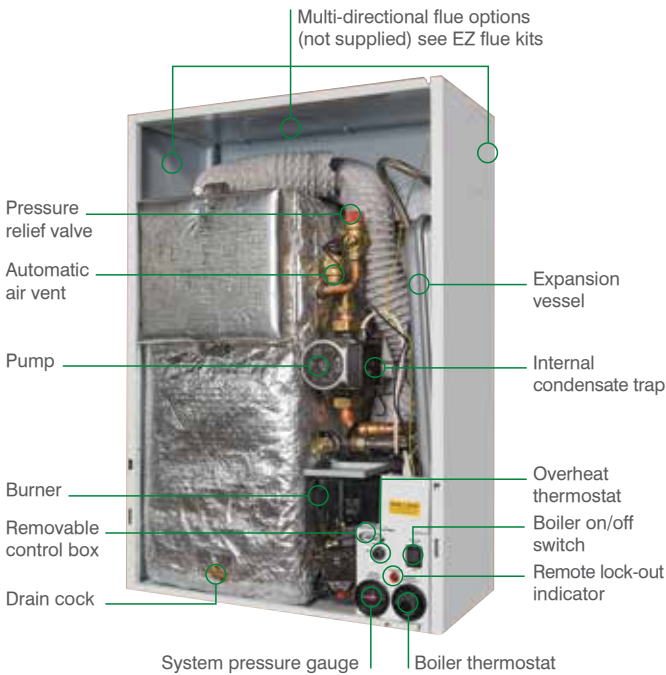

Model shown:  
VTXSWH1216 (front view)



## Grant Vortex Eco Wall Hung external/ external system models

VTXOMWH1216 / VTXOMWH1621 / VTXSOMWH1216 / VTXSOMWH1621

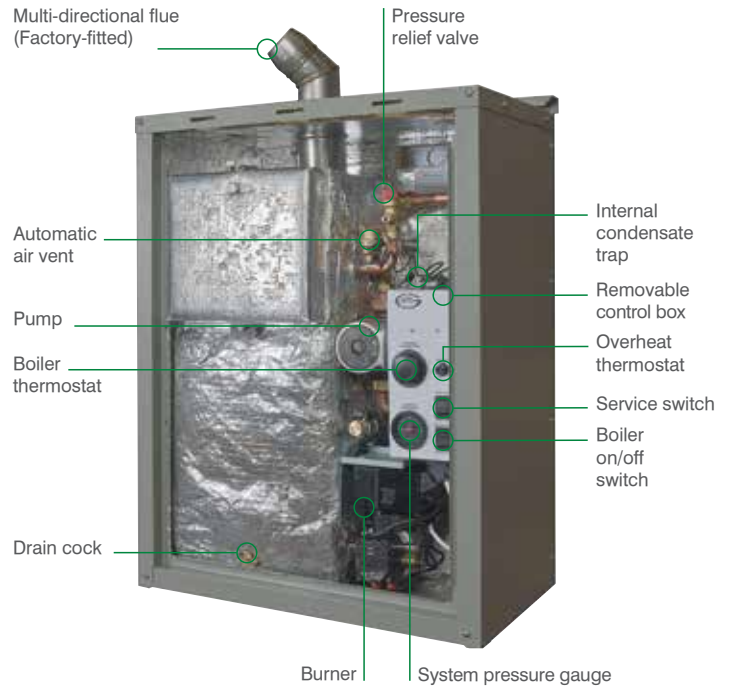

Model shown:  
VTXSOMWH1216 (front view)



Technical specifications								
Model	Internal models		Internal system models		External modules		External system modules	
	12-16	16-21	12-16	16-21	12-16	16-21	12-16	16-21
Output kW	12 to 16	16 to 21	12 to 16	16 to 21	12 to 16	16 to 21	12 to 16	16 to 21
Output Btu/h	40-55,000	55-70,000	40-55,000	55-70,000	40-55,000	55-70,000	40-55,000	55-70,000
Flow connection	22mm	22mm	22mm	22mm	22mm	22mm	22mm	22mm
Return connection	22mm	22mm	22mm	22mm	22mm	22mm	22mm	22mm
Cold water in	n/a	n/a	15mm	15mm	n/a	n/a	15mm	15mm
Pressure relief	n/a	n/a	15mm	15mm	n/a	n/a	15mm	15mm
Weight (dry)	86kg	86kg	93kg	93kg	92kg	92kg	99kg	99kg
Condensate pipe	21.5mm OD plastic overflow pipe							

**Note 1:** The boiler flow connection exits the casing on the top or bottom.  
**Note 2:** The return connection is located on the right and the condensate drain on the left.

### Vortex Eco wall-mounted programmer options



Optional Grant ES Kit, wall-mounted twin-channel programmer.



Optional Grant RS Kit wall-mounted programmable room thermostat.

# Grant Vortex Pro Kitchen/Utility range

## Introduction

The Grant Vortex Pro Kitchen/Utility range has been upgraded to enable a number of new programmer options to be used with the appliance.

A plug-in programmer (Product code: EPKIT) can be installed within the fascia, or alternatively, the receiver for Grant's new wireless RFT Kit (Product code: RFTKIT) can be located within the knockout and the programmer sited conveniently within the building.

The boilers have very high SAP 2009 gross seasonal efficiencies of between 90.7 - 93.3% and feature the 'award winning' unique Grant Vortex stainless steel condensing heat exchanger, and turbulator baffle system. The 15-21 utility model has been designed to fit within a kitchen unit and, due to its reduced width, can be used as a direct replacement for most older oil-fired boilers.

There are nine models within the range covering outputs from 15-70kW (50,000-240,000 Btu/h), all of which feature Grant's new internal condensate trap.

## Sealed system models

Sealed system variants of the Kitchen/Utility range are available in outputs of 15-26kW, 26-36kW and 36-46kW. Larger models above 46kW can also be converted to sealed system operation.



## Dimensions (mm)

### Grant Vortex Pro 15-21 Kitchen/Utility

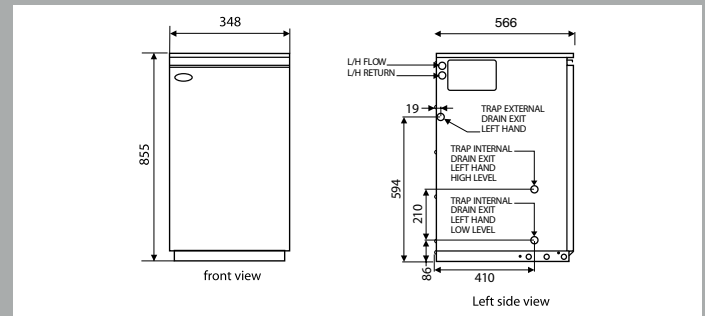

### Grant Vortex Pro 15-26 Kitchen/Utility and system

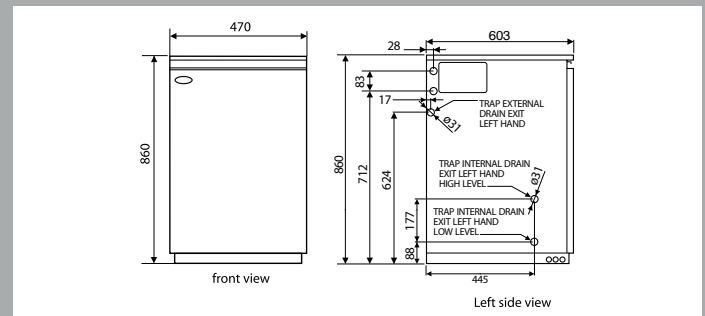

### Grant Vortex Pro 26-36 and 36-46 Kitchen/Utility and system

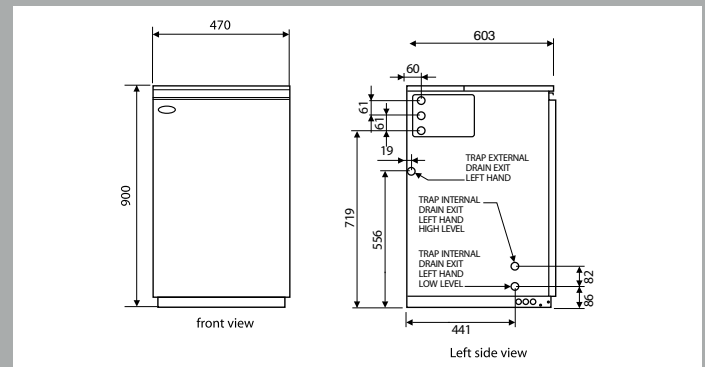

### Grant Vortex Pro 46-58 and 58-70 Kitchen/Utility

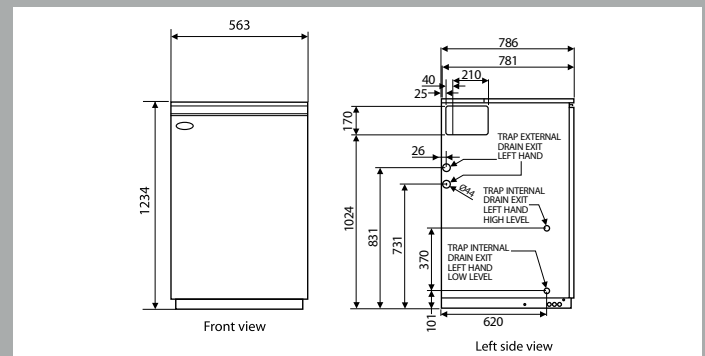

## Grant Vortex Pro Kitchen/Utility models

VTX1521 / VTX1526 / VTX2636 / VTX3646 / VTX4658 / VTX5870



Model shown: VTX1521 (front view)



## Grant Vortex Pro Kitchen/Utility sealed system models

VTXS1526 / VTXS2636 / VTXS3646



Model shown: VTXS1526 (front view)



Technical specifications	Kitchen/Utility models						Kitchen/Utility system models		
	15-21	15-26	26-36	36-46	46-58	58-70	15-26S	26-36S	36-46S
Output kW	15 to 21	15 to 26	26 to 36	36 to 46	46 to 58	58 to 70	15 to 26	26 to 36	36 to 46
Output Btu/h	50-70,000	50-90,000	90-123,000	123-157,000	157-200,000	200-240,000	50-90,000	90-123,000	123-157,000
Flow connection	22mm	22mm	28mm	28mm	1 1/4" BSP	1 1/4" BSP	22mm	28mm	28mm
Return connection	22mm	22mm	28mm	28mm	1 1/4" BSP	1 1/4" BSP	22mm	28mm	28mm
Cold water in (system kit)	n/a	n/a	n/a	n/a	n/a	n/a	15mm	15mm	15mm
Pressure relief (system kit)	n/a	n/a	n/a	n/a	n/a	n/a	15mm	15mm	15mm
Weight (dry)	98kg	128kg	148kg	148kg	275kg	281kg	145kg	169kg	169kg
Condensate pipe	21.5mm OD plastic overflow pipe								

**Note 1:** The boiler flow and return connections exit the casing on the left or right hand side.  
**Note 2:** Grant Vortex Pro Kitchen/Utility boilers are suitable for fully pumped systems only.

### Vortex Pro Kitchen/Utility programmer options



Optional Grant EP Kit. Electronic twin-channel plug-in programmer.



Optional Grant RFT Kit. Wireless twin-channel programmable thermostat.

**Note:** It is also possible to control Grant Vortex Pro Kitchen/Utility models with the optional twin channel programmer (ES Kit - see page 5).

# Grant Vortex Pro External range

## Introduction

The Grant Vortex Pro range of external modules encompass Grant's original Vortex heat exchanger and have some of the highest efficiencies available today. The boilers are available in four outputs ranging between 15kW and 70kW (50-240,000 Btu/h).

## Bespoke features

All Pro External modules enjoy the same unique features as the Eco External modules including the factory fitted multi-directional flue, high quality external powder coated casing, built in frost protection, mains isolating switch and a test switch. However, in addition, the boilers have a higher efficiency level and are factory wired to receive an 'optional' RF (radio frequency) wireless programmer. In this situation, the receiver can be plugged into the control panel of the module, enabling the boiler to be operated using a remote controller from any room inside the house, without the need for hard wiring.

## Sealed system kits

Grant Vortex Pro External condensing modules can be converted to sealed system operation by purchasing a pre-assembled kit from Grant UK. The sealed system kit includes an expansion vessel (size varies), automatic air vent, pressure relief valve and circulating pump. A filling loop and pressure gauge are also supplied as part of the kit. These can be fitted within the module casing, or ideally in a convenient site within the building, located between the cold main and central heating return.



## Dimensions (mm)

### Grant Vortex Pro External 15-21

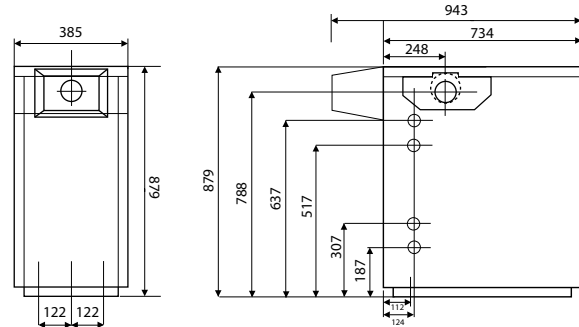

### Grant Vortex Pro External 15-26 26-36 36-46

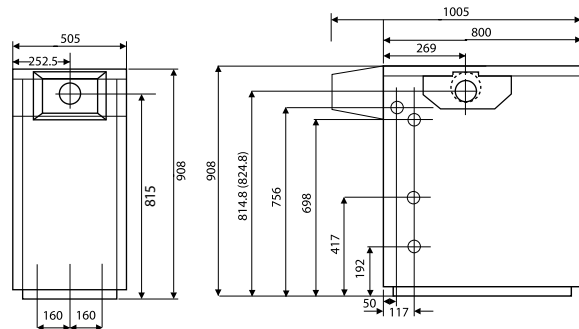

### Grant Vortex Pro External 46-58 58-70

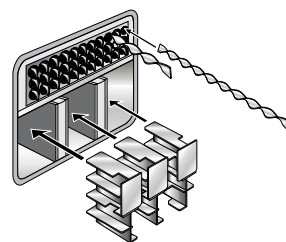
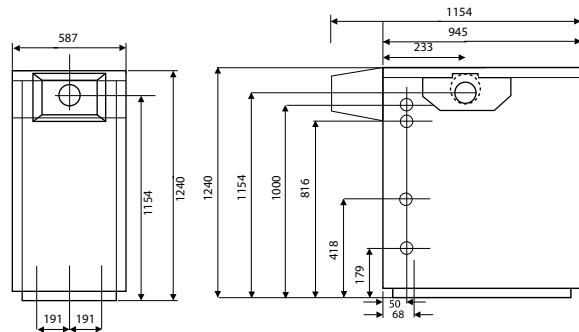

Baffle arrangement Grant Vortex 26-36 External module



Optional side flue outlet

## Grant Vortex Pro External modules

VTXOM1521 / VTXOM1526 / VTXOM2636 / VTXOM3646 / VTXOM4658 / VTXOM5870

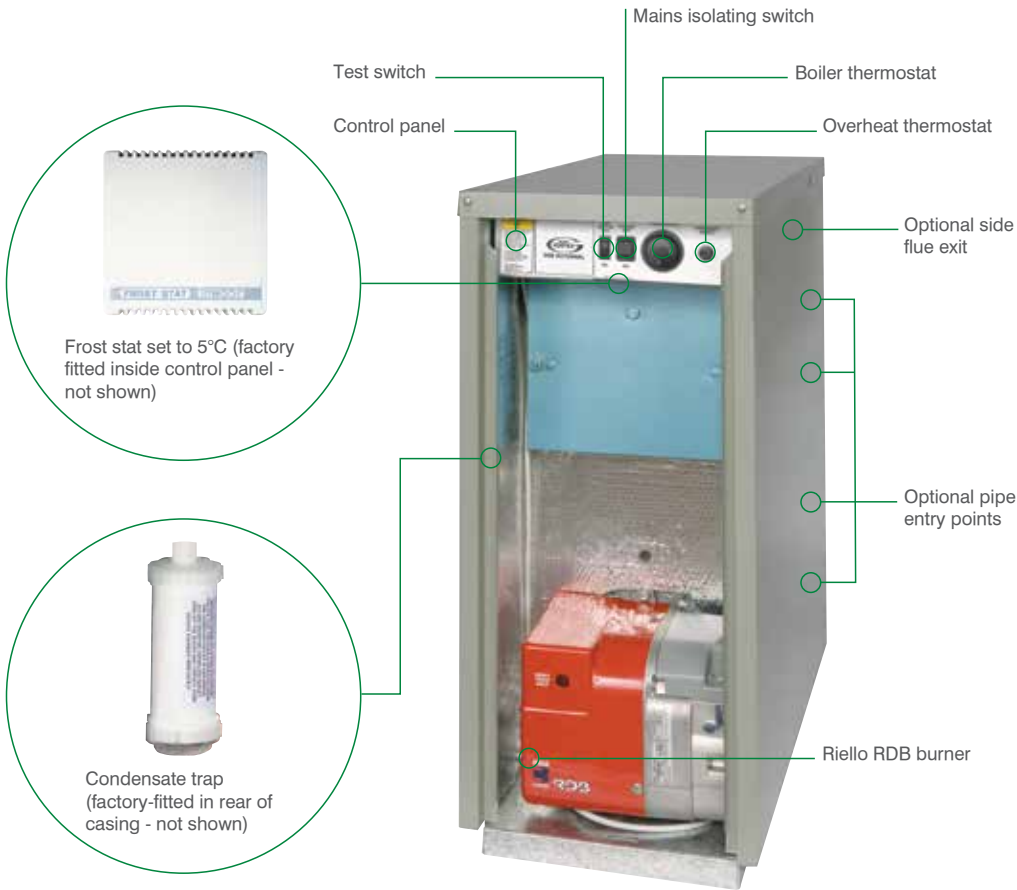

Model shown: VTXOM1526 (front view)



Technical specifications - boiler connections						
Model	Pro External modules					
	15-21	15-26	26-36	36-46	46-58	58-70
Output kW	15 to 21	15 to 26	26 to 36	36 to 46	46 to 58	58 to 70
Output Btu/h	50-70,000	50-90,000	90-123,000	123-157,000	157-200,000	200-240,000
Flow connection	22mm	22mm	28mm	28mm	1 1/4" BSP	1 1/4" BSP
Return connection	22mm	22mm	28mm	28mm	1 1/4" BSP	1 1/4" BSP
Cold water in (system kit)	15mm	15mm	15mm	15mm	15mm	15mm
Pressure relief (system kit)	15mm	15mm	15mm	15mm	15mm	15mm
Weight (dry)	95kg	145kg	159kg	159kg	294kg	300kg
Condensate pipe	21.5mm OD plastic overflow pipe					

**Note 1:** All boiler connections can be positioned to the left or right of the appliance.  
**Note 2:** Grant Vortex Condensing modules are suitable for fully pumped systems only.

### Vortex Pro External programmer options



Optional Grant RFT Kit. Wireless twin-channel programmable thermostat.

**Note:** It is also possible to control Grant Vortex Pro External models with the optional twin channel programmer (ES Kit - see page 5).

# Grant Vortex Pro Combi range

## Introduction

For almost two years Grant has been working behind the scenes on brand new electronic versions of the successful Grant Vortex Combi range with the aim of incorporating as many of the additional features and benefits customers have requested, whilst bringing the technology installed in these appliances up to the minute.

The models now include internal frost protection, neon diagnostic indicators and a factory fitted internal condensate trap (this can be sited externally if preferred), which is designed to make installation and servicing easier. The Grant Vortex Pro Electronic Condensing Combi's are available as internal or external models in three sizes, 21kW, 26kW\* and 36kW.

## Unique designs

Grant Vortex Pro Combi features much larger heat exchangers which, due to their low water content and larger surface area, vastly increase the hot water performance available and mixing valves are pre-set at 50°C, controlling accurately the hot water draw off temperature from the boiler. They also feature a low system pressure cut off switch, enabling the combi to protect itself in the unlikely event of system water loss. Additionally, there are two very accurate electronic temperature controls which allow the boiler to operate in condensing mode on central heating, whilst maintaining its instant hot water production.



\* Grant Vortex Pro Combi 26kW internal - Awarded 'Which? Best Buy 2008'.

## Dimensions (mm)

### Grant Vortex Pro Combi internal 21e and 26e

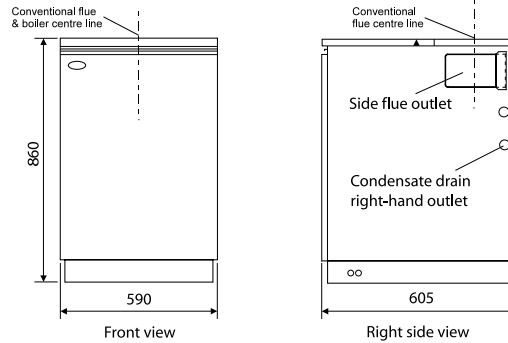

### Grant Vortex Pro Combi internal 36e

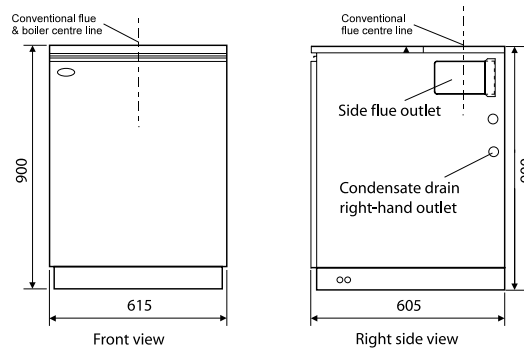

### Grant Vortex Pro Combi external 21e, 26e and 36e

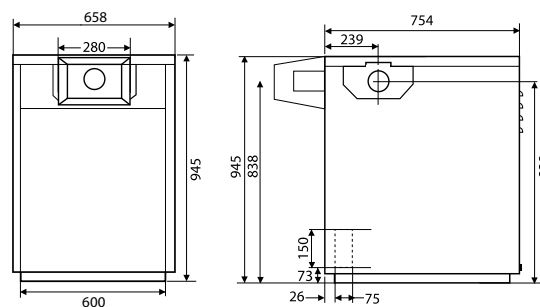

## Typical hot water performance

VTXCOMBI21\* 15 litres per minute at an average temperature of 50°C. Recovery time 4 minutes approx. Based upon 100 litre draw off.

VTXCOMBI26\* 17 litres per minute at an average temperature of 50°C. Recovery time 4 minutes approx. Based upon 100 litre draw off.

VTXCOMBI36\* 20 litres per minute at an average temperature of 50°C. Recovery time 3 minutes approx. Based upon 100 litre draw off.

### Mains water pressure

Minimum: 2.5bar (36psi). Maximum: 8bar (115psi).

\* Hot water flow rate is dependent on mains pressure available. Figures based upon an incoming mains water temperature of 10°C.

## Grant Vortex Pro Combi internal models

VTXCOMBI21 / VTXCOMBI26 / VTXCOMBI36

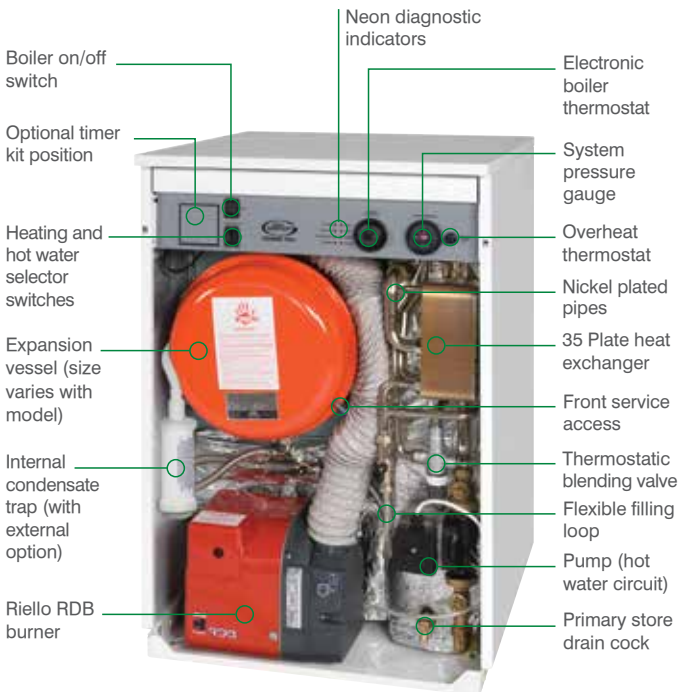

Model shown:  
VTXCOMBI26 (front view)



## Grant Vortex Pro Combi external modules

VTXOMCOMBI21 / VTXOMCOMBI26 / VTXOMCOMBI36

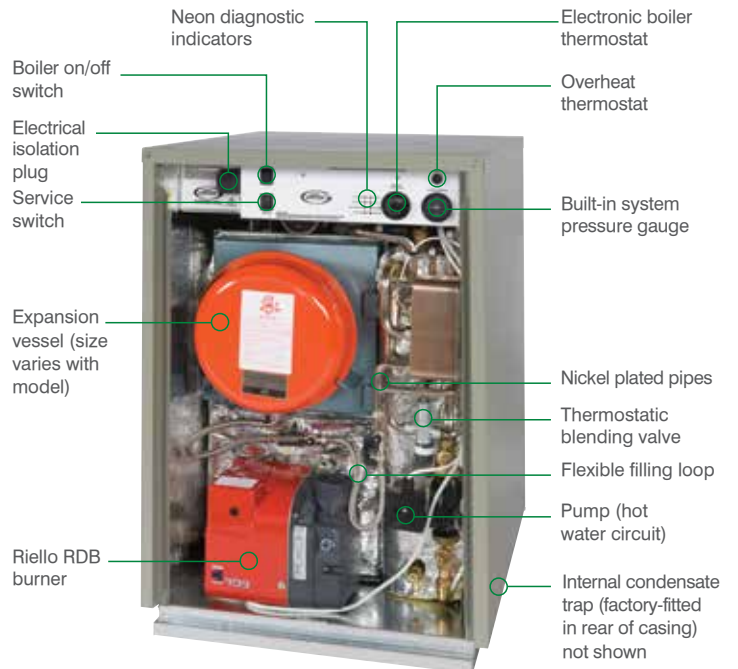

Model shown:  
VTXOMCOMBI26 (front view)



Technical specifications - boiler connections						
Model	Pro Combi internal models			Pro Combi external modules		
	21	26	36	21	26	36
Output kW	21	26	36	21	26	36
Output Btu/h	70,000	90,000	123,000	70,000	90,000	123,000
Flow connection	22mm	22mm	28mm	22mm	22mm	28mm
Return connection	22mm	22mm	28mm	22mm	22mm	28mm
Cold water in	15mm	15mm	22mm	15mm	15mm	22mm
Hot water out	15mm	15mm	22mm	15mm	15mm	22mm
Pressure relief	15mm	15mm	15mm	15mm	15mm	15mm
Weight (dry)	148kg	173kg	199kg	171kg	197kg	221kg
Condensate pipe	21.5mm OD plastic overflow pipe					

**Note 1:** All boiler connections can be positioned to the left or right of the appliance.  
**Note 2:** Grant Vortex Pro internal and external condensing Combi's are suitable for fully pumped systems only.

### Vortex Pro Combi timer options



Optional Grant MT Kit. Single-channel mechanical timer.



Optional Grant RFT Kit. Wireless twin-channel programmable thermostat.

**Note:** It is also possible to control Grant Vortex Pro Combi's with the optional twin channel programmer (ES Kit - see page 5).

# Grant Vortex Pro Boiler House range

## Introduction

The new Grant Vortex Pro Boiler House models come as a blue cased unit with an externally mounted Riello RDB burner and thermostat.

These boilers are ideal for locations that are difficult to access like cellars or plant rooms, where a white cased utility version is not always the best solution.

There are four models available with outputs of 26-36kW, 36-46kW, 46-58kW and 58-70kW. All have high SAP 2009 seasonal efficiencies between 90.7% and 93.3%.

The boilers encompass the same unique stainless steel heat exchangers used in other Vortex boilers together with Grant's exclusive turbulator baffle system, which provides ultra-high efficiency and low running costs.

Grant Vortex Pro Boiler House models are compatible with all of Grant's EZ-Fit flue options and are flued in exactly the same way as Kitchen/Utility models.



Model shown: Grant Vortex Pro 46-58kW Boiler House model installed in a cellar

## Dimensions (mm)

### Grant Vortex Pro Boiler House 26-36 and 36-46

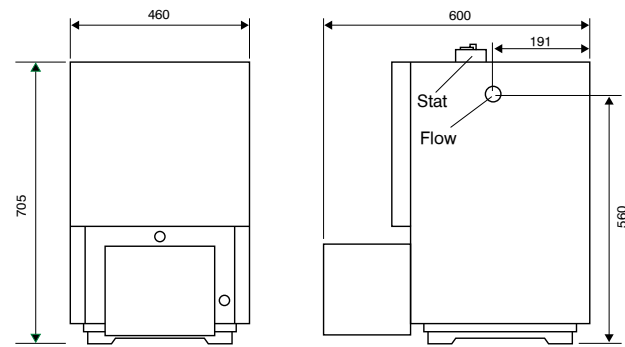

### Grant Vortex Pro Boiler House 46-58 and 58-70

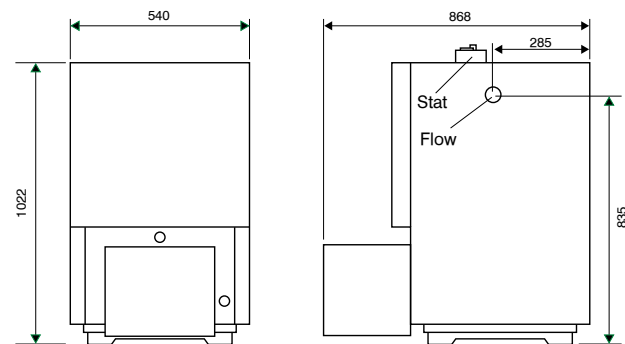



## Grant Vortex Pro Boiler House models

VTXBH2636 / VTXBH3646 / VTXBH4658 / VTXBH5870

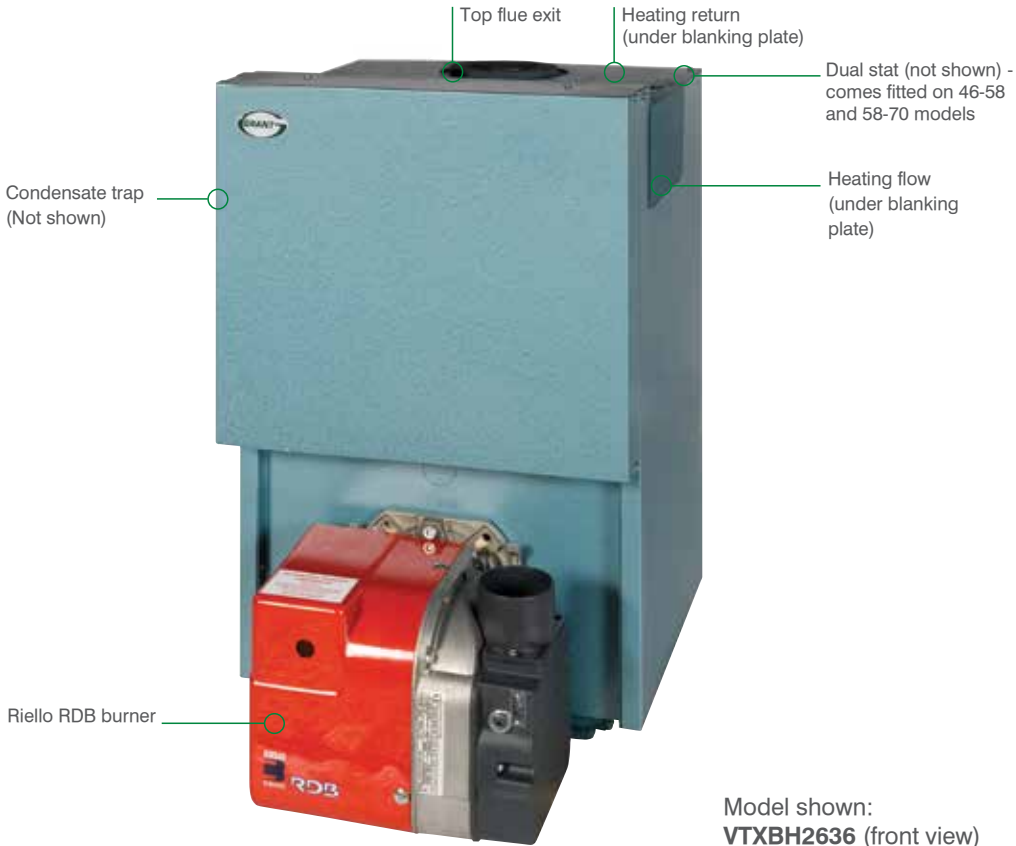

Model shown:  
VTXBH2636 (front view)



### Technical specifications - boiler connections

Model	Boiler House models			
	26-36	36-46	46-58	58-70
Output kW	26 to 36	36 to 46	46 to 58	58 to 70
Output Btu/h	90-123,000	123-157,000	157-200,000	200-240,000
Flow connection	28mm	28mm	11/4" BSP	11/4" BSP
Return connection	28mm	28mm	11/4" BSP	11/4" BSP
Cold water in (system kit)	n/a	n/a	n/a	n/a
Pressure relief (system kit)	n/a	n/a	n/a	n/a
Weight (dry)	122kg	122kg	229kg	236kg
Condensate pipe	21.5mm OD plastic overflow pipe			

**Note 1:** The boiler flow and return connections exit the casing on the left or right hand side.  
**Note 2:** Grant Vortex Pro Boiler House boilers are suitable for fully pumped systems only.

### Vortex Pro Boiler House programmer options



Optional Grant EP Kit. Electronic twin-channel plug-in programmer.



Optional Grant RFT Kit. Wireless twin-channel programmable thermostat.

**Note:** It is also possible to control Grant Vortex Boiler House models with the optional twin channel programmer (ES Kit - see page 5).

# Compatible products

## Introduction

Grant Vortex oil-fired boilers are one of the most efficient heating systems on the market. We also have other products in our wider range that work in conjunction with the Grant Vortex to deliver even more efficiency and cost savings as well as increasing the environmental credentials even further.

---

## Making your system even more environmental

Combining a Grant oil-fired system with a renewable technology like Grant Solar Thermal is an excellent way to keep fuel costs down and to ensure your household is as energy efficient as possible. Solar Thermal systems are easy to install, and when combined with our oil-burning systems could provide up to 70% of your hot water needs, reducing your fuel costs and protecting the environment too.



## EZ-Fit flue systems

All Grant Vortex oil-fired boilers are supplied for connection to either a 'stainless steel' conventional flue, or one of Grant's EZ-Fit flue options. The flue systems are available as low level, high level or vertical kits, for internal and external applications, and even as unique EZ-Flexi packs, designed to enable condensing boilers to utilise an existing chimney. All our EZ-Fit flues carry the CE mark of approval, are adaptable to any installation, and deliver excellent value for money.

To find out more about our environmentally responsible heating products, including biomass boilers, air source heat pumps, cylinders, thermal stores and control systems visit: [www.grantuk.com](http://www.grantuk.com) or call us on: 01380 736920.



# General information

## Installation and commissioning

Installation must comply with the current British Standards and The Building Regulations. Comprehensive technical information can be found in the installation manual, supplied with every boiler.

As with all oil-fired appliances, Grant Vortex condensing boilers require commissioning at the time of installation. This simple process ensures that the boiler is working at peak efficiency which, in turn, will result in lower running costs and long term reliability.

## Plumbing

Condensing boilers operate at extremely high efficiency levels, producing cool flue gas temperatures, resulting in a 'plume' of vapour being visible at the flue terminal. This plume (steam) is a normal condition of condensing boiler operation and indicates that the appliance is working efficiently.

Low level balanced, high level, or vertical flue kits are available, which moves the plume to a higher level. Alternatively, it is possible to convert an existing low level balanced flue to an external high level or vertical arrangement using Grant's Plume Diverter.

## Guarantees

The unique heat exchanger on Grant Vortex condensing boilers is covered by a 5-year guarantee. All other component parts of the boiler are guaranteed for 2 years from the date of purchase (excluding consumable items), subject to being installed in accordance with the manufacturers instructions. There are also optional annual, or 3-year extended warranty schemes available. On completion of the installation all Grant Vortex condensing boilers must be commissioned and the guarantee registration form completed online.

## Aftersales service

For peace of mind, all Grant central heating boilers are backed by a national network of independent service engineers. In the unlikely event of a problem occurring, your installer should telephone our Customer Service Department on: 01380 736920.

## Standard Assessment Procedure (SAP)

SEDBUK was developed by the Government alongside boiler manufacturers, under their 'Energy Efficiency Best Practice Programme'. It was designed as a fair basis for comparisons of boiler energy performance when installed in a typical domestic situation in the UK.

To determine boiler efficiencies, a 'Standard Assessment Procedure' more commonly known as SAP, is used. SAP is the Government's standard method for energy rating. SAP ratings enable the comparison of energy efficiencies and demonstrate the likely effect of improvements to a property in terms of energy use.

Since SEDBUK was introduced in 1999, it has undergone many changes, the most recent being the move from SAP 2005 to SAP 2009. The changes focus on improving the accuracy of the way the efficiencies are worked out.

SAP 2009 incorporates a key revision in the assumed carbon emissions per kWh of oil used by the boiler. It may appear that the efficiencies of boilers have reduced with SAP 2009, but it is important to understand that the new methodology gives a more realistic estimate of the average annual boiler efficiency when installed in typical conditions, based on evidence from recent independent testing and field trials.

## Fuel

The burner on all Grant Vortex boilers is supplied factory set at the stated output for use on standard grade kerosene - Class C2.

Grant Vortex condensing boilers manufactured from May 2011 onwards, however, will have a new 'bio compatible' burner fitted which is also suitable for biokerosene at a 30% blend, known as B30.

To use B30 fuel, it will be necessary to change the oil feed line and ensure that other components used during installation e.g oil tank, etc. are suitable. Grant Vortex condensing boilers must not be used with Class D gas oil.

This leaflet is accurate at the time of printing but as Grant UK has a policy of continual improvement it may be superseded. We reserve the right to amend specifications without prior notice. The statutory rights of the consumer are not affected.

All products manufactured under I.S. EN ISO 9001 and ISO 14001.

™The Grant 'EZ-Fit flue' system is a Trade Mark of Grant Engineering Limited.

®Grant Aerona, Grant Spira, Grant Vecta, Grant Vortex, Grant Solar, Grant Aurora, Grant Sahara, Grant CombiSOL, Grant WinterSOL, Grant MonoWave, Grant DuoWave, Grant ThermoWave, Euroflame and Multi Pass are registered trade marks of Grant Engineering Limited. The contents of this leaflet are fully protected by copyright and nothing may be reproduced without permission from Grant UK.



**Grant Engineering (UK) Ltd**  
Hopton House, Hopton Industrial Estate,  
Devizes, Wiltshire, SN10 2EU

T: 01380 736920 F: 01380 736991  
E: [sales@grantuk.com](mailto:sales@grantuk.com) W: [www.grantuk.com](http://www.grantuk.com)

