

# **PH-3-8L-HW**

---

## **Hot Water & Condensate Pump Installation Instructions**



*Pump House*  
Glaisdale Drive East, Nottingham, NG8 4LY  
Tel ~ 0115 900 5858 Fax ~ 0115 929 4468  

---

Email ~ [sales@pumphousepumps.com](mailto:sales@pumphousepumps.com) Website ~ [www.pumphousepumps.com](http://www.pumphousepumps.com)



# PH-3-8L-HW Installation Instructions

## SPECIFICATION PH-3-8L-HW

Model	PH-3-8L-HW	Height	249 mm
Max Flow	312 lph	Inlet Height	115 mm
Max Head	8m	Length	325 mm
Tank Capacity	3.8 litres	Width	160 mm
Volts	240 V / 0.75 A	Cable Length	1.8 m
Hz	50 Hz		
Discharge Size	3/8"		
High-level Alarm	Volt Free		

## INSTALLATION

1. This condensate pump is designed as an automatic removal device for pumping away condensate from condensing boilers and high temperature water up to 100°C. The pump is controlled by a float / switch mechanism which turns the pump on to discharge the condensate when approximately 57mm of condensate collects in a tank. The pump switches off automatically when the tank drains to approximately 19mm.
2. This pump is carefully packaged, inspected and tested to ensure safe operation and delivery. When you receive the pump, examine it carefully to determine that there are no broken or damaged parts that may have occurred during shipment. If damaged has occurred, please contact your supplier. They will assist you in replacement or repair, if required.
3. Read the instructions carefully before attempting to install, operate or service the pump. Know the pump application, limitations and potential hazards. protect yourself and others by observing all safety information. Failure to comply with instructions could result in personal injury and/or property damage! Please retain these instructions for future reference. Installation and connections are to be made by a qualified person.

## SAFETY

1. Do not use to pump flammable or explosive fluids such as petrol, fuel oil, kerosene, etc. Do not use in explosive atmospheres. This pump should be used with liquids compatible with the pump component materials.
2. Do not handle the pump with wet hands or when standing on a wet or damp surface, or in water. To reduce the risk of electrical shock, be certain that the electrical supply is connected to a permanent EARTH.
3. For installations where property damage and/or personal injury might result from an inoperative or leaking pump due to power cuts, discharge line blockage, or any other reason, a backup system and/or alarm should be used.
4. Support the pump and piping when assembling and when installed. Failure to do so may cause piping to break, pump to fail, motor bearing failures, etc

For further installation advice please call the technical support helpline on 0115 900 5858.

# PH-3-8L-HW Installation Instructions

## INSTALLING THE PUMP

1. Carefully unpack the pump
2. The pump is designed to be floor standing and it is essential that the pump must sit on a level surface. Optional: you may wish to mount the pump on wall brackets.
3. The pump should not be installed in a manner that will subject it to splashing or spraying.
4. The following installation pipe routing options are available:

## ELECTRICAL CONNECTIONS

1. Shut off electrical power at fuse box for both the pump and equipment before making any connections. All wiring must comply with appropriate codes.
2. Connect the pump to voltage specified on label located on the pump:  
Live - BROWN  
Neutral - BLUE  
Earth - YELLOW / GREEN
3. If separate fused spur or plus is used, a 3.0 Amp fuse is recommended.
4. Connection of the high level safety switch / potential free contact must be made to either the 240v circuit volt free equipment connector or an audible alarm. The pump is fitted with a 240v micro switch (max current rating 3A), which will activate if the pump starts to overflow in the event of outlet pipe blockage or pump failure. The following wiring diagrams show how the switch can be connected into a boiler circuit or a separate audible alarm.

Boiler Connection (Max. 3A)

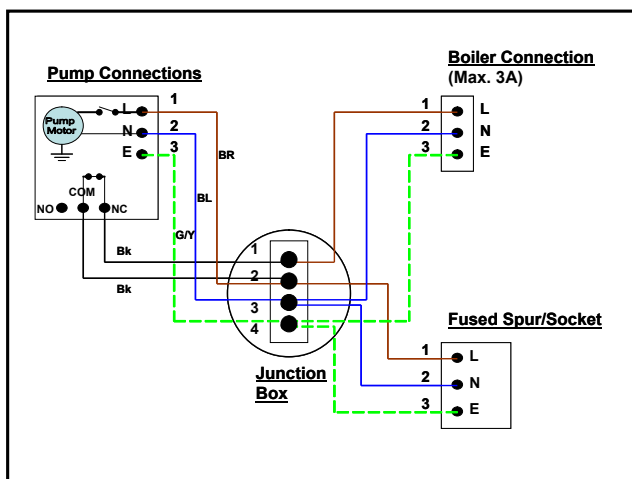

Volt Free Connection

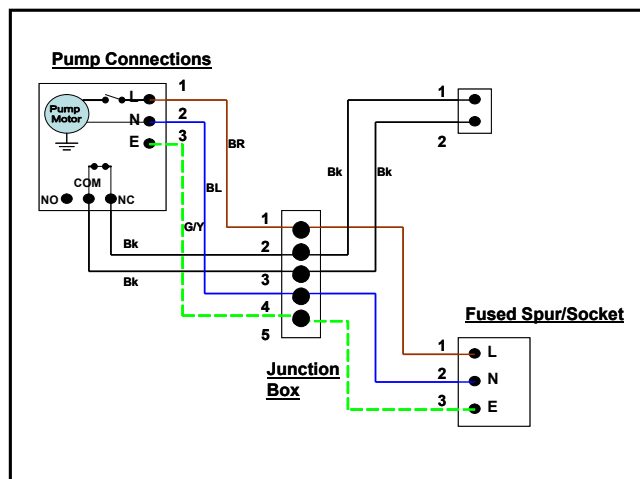

For further installation advice please call the technical support helpline on 0115 900 5858.

# PH-3-8L-HW Installation Instructions

## DRAIN CONNECTION

### INLET CONDENSATE DRAIN CONNECTION

1. Position the pump beneath the equipment / units so that condensate or high temp outlet flows into pump inlet freely (use either of the two openings provided) - when hot water at pressure is connected always use a tundish prior to entering the pump.
2. The inlet pipe should be positioned as close to the bottom of the tank as possible and the bottom cut at an angle of greater than 30° to ensure the free flow of the condensate from the boiler.

### OUTLET CONDENSATE CONNECTIONS

1. Connect the 3/8" I.D tubing to the discharge adapter / non return valve. For best result, secure tubing with clamps but do not pinch, collapse or otherwise restrict the tubing.

The non return valve has a quick release mechanism with a 1/4 turn bayonet type fitting.

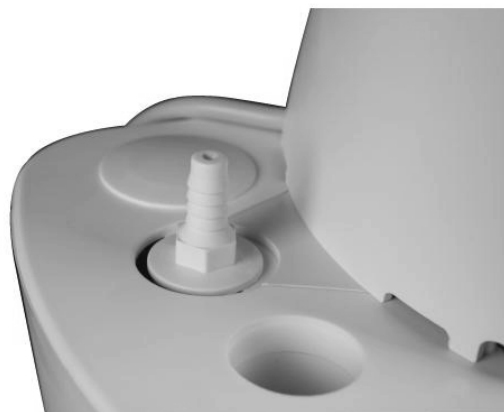

1/4 TURN NON RETURN VALVE

2. Tubing should rise vertically but not exceed the maximum shut off head (pumping height) of 8 metre above the pump. Any horizontal runs should be taken into consideration when assessing the maximum shut off. This shut off will be reduced if bends and horizontal runs are included in the outlet pipe work. If in doubt please contact Pump House for advice.
3. At highest point angle tubing horizontally and create a downward slop to drainage point. Do not bend sharply or twist the tubing in a way that might result in collapse or restriction of the tubing. Creating a downward slope will allow condensate to drain by gravity and keep tubing empty.
4. If not possible to create a downward slope, try to create an inverted "U" trap directly above the pump at the highest point.

## COMMISSIONING & TESTING

1. Before commissioning, check for debris in the tank. Remove any material which might block the drain line or drain into the pump tank.
2. Turn on power
3. Slowly fill the tank with clean water, as the float rises to the On Level position the motor should turn on.
4. Leave the clean water in the tank as this will effectively prime the pump ready for use and help to prevent any flue products passing through the pump from the boiler condensate drain pipe.

This pump is designed for use with condensing boiler applications. Caution must be taken to ensure acidity of condensate does not increase below the average pH of 3.0 (to prevent localised pocket of acid that acts like a battery causing pitting) by routinely cleaning or flushing tank with fresh water.

For further installation advice please call the technical support helpline on 0115 900 5858.

# PH-3-8L-HW Installation Instructions

## MAINTENANCE & SERVICING

1. Before servicing the pump, disconnect the electric power at the fuse box for both the pump and the equipment unit.
2. It is recommended that the pump be checked every six months for proper operation. Most important is to check for debris blocking the pump discharge adapter/non return valve. Check for proper free movement of pump float and switch and check for free, unrestricted movement of motor and fan.
3. Clean the holding tank and float with warm water and mild soap. Rinse completely when finished.
4. Check the inlet and outlet piping. Clean as necessary. Be sure there are no kinks in the outlet line that would inhibit or restrict flow.

## WARRANTY

This pump offers a 1 year warranty. This warranty covers all parts with material or manufacturing faults. The buyer's only remedy is the replacement or repair of the defective parts. In no case can labour costs and any consequential damage be cited as a basis for a complaint. Any returned units must be complete and must be accompanied by a written list of the defects ascertained.

We are unable to accept any liability in case of nonconforming installation or noncompliance with the specifications or maintenance recommendations.

## CONFORMITY



All data contained in these specifications are solely intended to describe the product and do not constitute warranted characteristics in the legal sense. Subject to technical change.

For further installation advice please call the technical support helpline on 0115 900 5858.