

# inta

---

## Anti-Ligature Shower Head

### VR995CP

## Installation and Maintenance Instructions

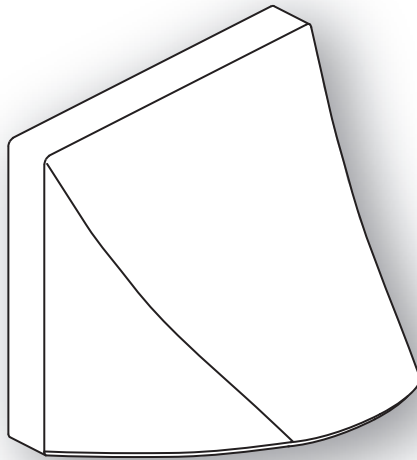

# inta

**Intatec Ltd**  
Mustang Drive  
Stafford  
Staffordshire  
ST16 1GW

In this procedure document we have endeavoured to make the information as accurate as possible.

We cannot accept any responsibility should it be found that in any respect the information is inaccurate or incomplete or becomes so as a result of further developments or otherwise.

© Intatec Ltd 2009

Tel: **01785 218230**  
Fax: **01785 218231**  
email: **sales@intatec.co.uk**  
web: **www.intatec.co.uk**

## Introduction

The Inta VR995CP anti-ligature vandal resistant shower head is intended for use in secure units.

The smooth flush design, with a concealed 1/2" BSP connection, is designed to be installed within the wall surface for extra security.

## Operating Conditions

Max. Operating Pressure	5 bar
Min. Operating Pressure	0.5 bar
Max. Inlet Temperature	65°C
Min. Inlet Temperature	5°C

## Flow Rates

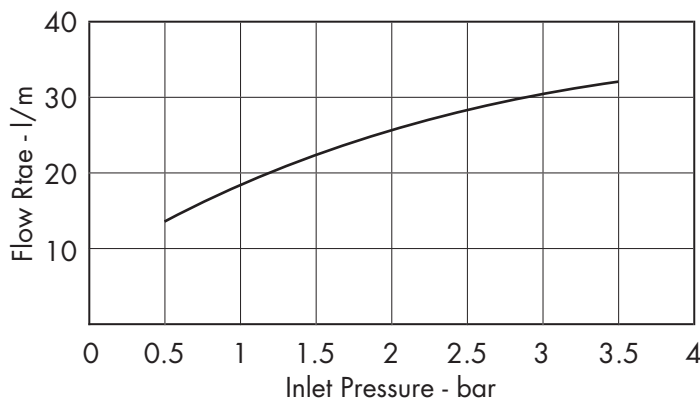

Altecnic have a range of WRAS approved water saving devices from 4 to 18 litres per minute, including the Calflow Plus featuring an integral ball valve and serviceable filter.

See website for details [www.altecnic.co.uk](http://www.altecnic.co.uk)

## Components

Before commencing ensure all parts are present, before discarding any packaging. If any parts are missing, do not attempt to install the shower head until the missing parts have been obtained.

Item	Qty	Components
------	-----	------------

1	1 x	Back plate
2	2 x	M6 nut and washer
3	2 x	M6 stud
4	1 x	Shower head inc. nozzle supply pipe and sealing washer

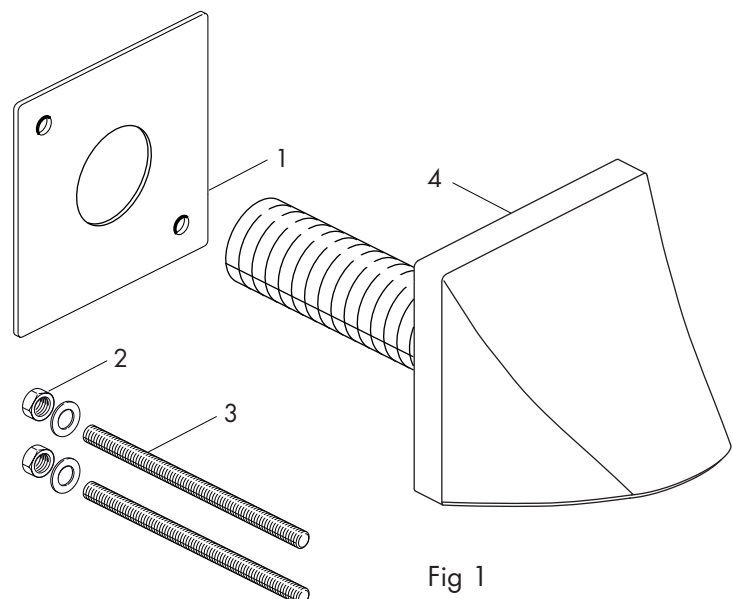

Fig 1

## Location

The shower head must be installed flush within the finished wall, to ensure there is no ligature point. See Fig 2.

The shower head should be installed at a height suitable for all users, we recommend a height of 2m.

The shower must not be positioned where it will be subjected to freezing condition.

## Dimensions

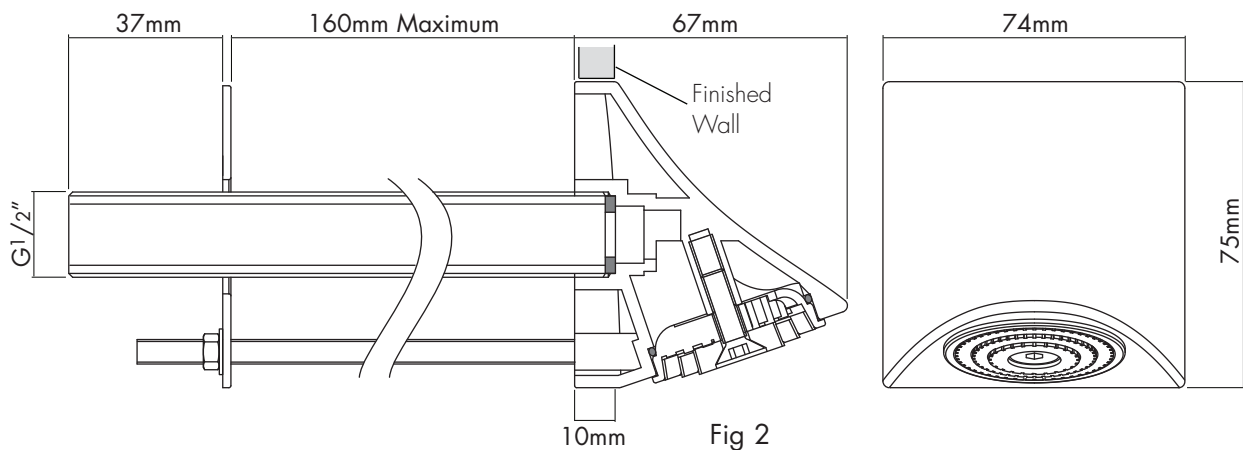

## Installation

The installation must be carried out strictly in accordance with the Water Supply (Water Fittings) Regulation 1999 and any local water authority regulations.

The VR995CP anti ligature shower head has been designed to be built into the wall, the finished wall must be flush as shown in Fig 2.

The VR995CP is the same size as a single electrical mounting box therefore the recommend method of creating the recess in the wall is to use an electrical box sinker, alternatively stitch drilling and a lump hammer can be used.

Position the backplate onto the wall and mark the position for the M6 stud fixing holes and the centre for the supply pipe. Use a spirit level to ensure the back plate is horizontal.

Drill pilot holes for the centres of the 3 holes.

Use the electrical box sinker tool to recess the wall to a finished depth of  $9\text{mm} \pm 0.5\text{mm}$ . If the wall is to be finished by wall tiles allow for the thickness of the tiles and the adhesive.

Drill two  $\text{Ø}10\text{mm}$  holes for the M6 fixing studs.

Drill the centre hole  $\text{Ø}30\text{mm}$  to allow for the supply pipe and fitting.

Fit the two M6 studs to the shower head.

Check that the shower head will be flush with the finished wall when installed.

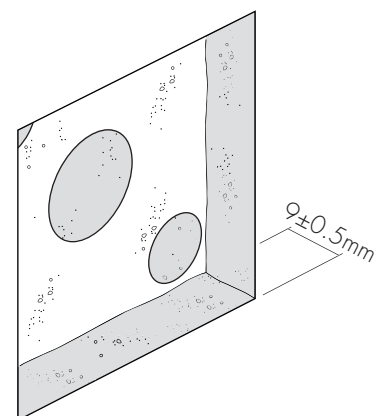
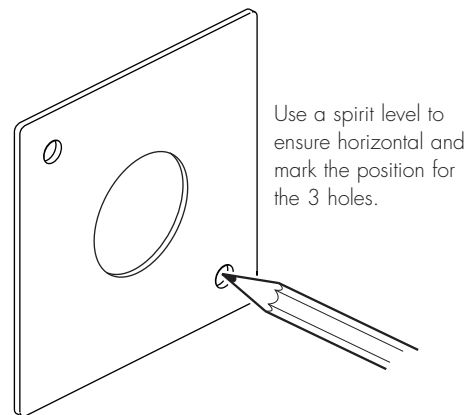

## Installation

Ensure the supply pipes are thoroughly flushed prior to fitting the shower head.

Fit the shower head assembly into the wall, fit the back plate and secure with the nuts and washers, do not overtighten.

Attach a 1/2" BSP female x 15mm compression fitting or swivel tap connector to the supply pipe (not supplied).

We recommend that 15mm BS EN 1057 R250 (half hard) copper tube is used.

Connect the supply using the compression joint.

Turn on the water supply and check joints for leakage.

Finish tiling the wall and grout the shower head into the tiles.

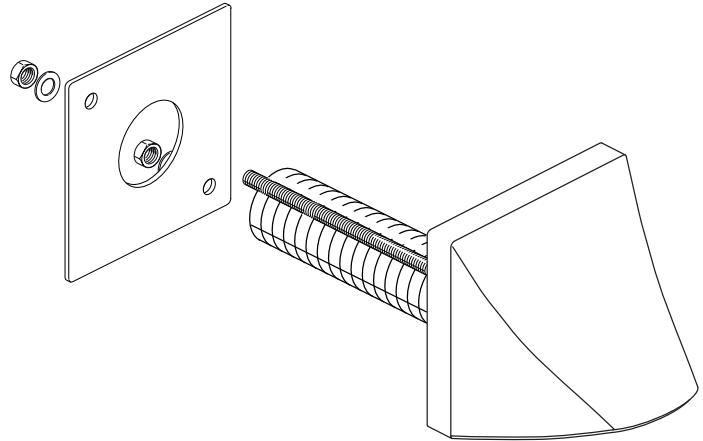

## Removing the Spray Head

If the discharge holes in the spray head become blocked, it can be removed and separated for cleaning.

Remove the spray head by unscrewing the counter sunk cap screw using the Allen key supplied.

The spray head consists of 3 separate plastic rings, gently push from the innerside to separate.

Clean and de-scale as appropriate.

Refit to the shower and secure with the counter sunk cap screw.

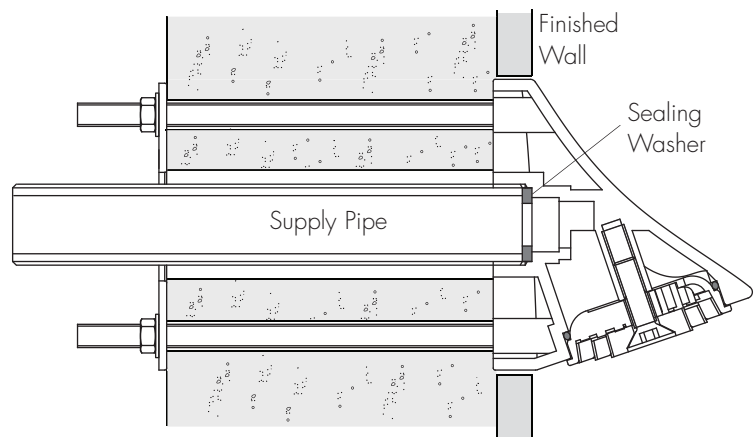

## Aftercare

To maintain the appearance of the shower head it should be periodically cleaned with a soft damp cloth and a mild detergent followed by a thorough rinsing.

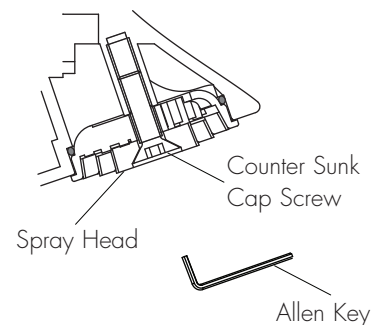

Please leave these instructions with the user