

Calculating the dimension of suction pipes for one-pipe systems 2,5-120 kg/h

When calculating the appropriate suction pipe dimension, pipe resistance and suction height must be taken into consideration. Different pipe dimensions allow different lengths of suction pipe. The tables below are only a recommendation, which show basic guidelines using theoretic values. Too low velocity will lead to air/gas separation from the oil resulting in large amounts of air/gas travelling to the pump causing noise and eventually flame failure.

Using a suction pipe with an oversized inner diameter will result in a loss of the siphon effect in the descending parts of the suction pipe. If an oversized inner diameter is unavoidable, all ascending parts of the suction pipe must be calculated as suction height instead of simply figuring the height from the lowest level in the oil tank to the oil pump. Remember that suction height must not exceed 4 meter, as this will lead to noise and unnecessary wear and tear on the pump.

The siphon effect must be calculated using the lowest potential flow in the suction pipe. For example, when using an oil burner with multiple effect stages, the lowest stage should be used to calculate siphon effect. The maximum effect stage should be used to calculate the pipe resistance.

When calculating the appropriate suction pipe dimension, siphon effect should be taken into consideration. The figures below show siphon effect at different flow velocities.

Inner diameter	Siphon effect starts at
4 mm	a flow > 1,6 kg/h
6 mm	a flow > 5,5 kg/h
8 mm	a flow > 20 kg/h
10 mm	a flow > 35 kg/h

The pipe system described below consists of a copper pipe, four elbows, a non-return valve, a shut-off valve and one Tigerloop Combi. When starting up with an empty pipe, simply press the reset button on the burner and the Tigerloop will automatically de-aerate the system. The oil pump should not run without oil for more than five minutes.

The tables below indicate the total suction length in meter at different heights and nozzle capacities. In a one-pipe system, the flow of the suction pipe is identical to the nozzle capacity.

Tank above the burner

An overpressure builds up in the descending parts of the pipe (siphon effect) as long as the lowest flow for siphon effect is exceeded. Otherwise, all ascending pipes must be calculated as suction height and the table “Tank below the burner or at the same level” should be used.

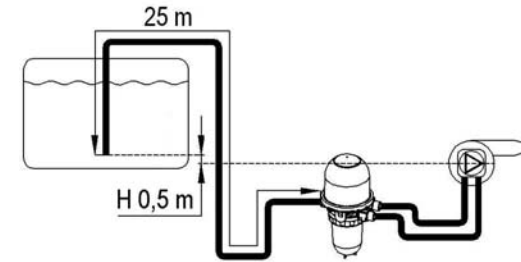

This table is valid for **standard fuel oil** with a viscosity of 6,0 mm²/s (cSt) (DIN 51603-1).

Height in m	Ø 4 Inner mm	Ø 5 Inner mm	Ø 4 Inner mm	Ø 5 Inner mm	Ø 6 Inner mm	Ø 5 Inner mm	Ø 6 Inner mm	Ø 6 Inner mm	Ø 8 Inner mm	Ø 6 Inner mm	Ø 8 Inner mm	Ø 6 Inner mm	Ø 8 Inner mm	Ø 6 Inner mm	Ø 8 Inner mm	Ø 8 Inner mm	Ø 10 Inner mm	Ø 8 Inner mm	Ø 10 Inner mm	Ø 8 Inner mm	Ø 10 Inner mm	
	Max. pipe length in m																					
+4,0	100	100	51	100	100	62	100	65	100	43	100	32	100	21	68	51	100	40	100	33	83	
+3,5	100	100	48	100	100	59	100	61	100	40	100	30	96	20	64	47	100	38	93	31	78	
+3,0	100	100	45	100	100	55	100	57	100	38	100	28	90	18	59	44	100	35	87	29	72	
+2,5	100	100	42	100	100	51	100	53	100	35	100	26	83	17	55	41	100	32	81	27	67	
+2,0	97	100	38	95	100	47	98	49	100	32	100	24	77	15	51	38	94	30	75	25	62	
+1,5	89	100	35	87	100	43	90	45	100	29	95	22	71	14	47	35	86	27	69	22	57	
+1,0	81	100	32	79	100	39	82	41	100	27	86	20	64	13	43	32	79	25	62	20	52	
+0,5	73	100	29	71	100	35	74	37	100	24	78	18	58	11	38	28	71	22	56	18	47	
Nozzle cap.	2,5 kg/h		5,0 kg/h			10 kg/h		20 kg/h		30 kg/h		40 kg/h		60 kg/h		80 kg/h		100 kg/h		120 kg/h		

This table is valid for **kerosene** with a viscosity of 2,15 mm²/s (cSt) 2800 min⁻¹.

Height in m	Ø 4 Inner mm	Ø 5 Inner mm	Ø 4 Inner mm	Ø 5 Inner mm	Ø 6 Inner mm	Ø 4 Inner mm	Ø 5 Inner mm	Ø 5 Inner mm	Ø 6 Inner mm	Ø 5 Inner mm	Ø 6 Inner mm	Ø 5 Inner mm	Ø 6 Inner mm	Ø 6 Inner mm	Ø 8 Inner mm	Ø 6 Inner mm	Ø 8 Inner mm	Ø 6 Inner mm	Ø 8 Inner mm	Ø 6 Inner mm	Ø 8 Inner mm	
	Max. pipe length in m																					
+4,0	100	100	100	100	100	74	100	90	100	59	100	44	93	61	100	45	100	35	100	28	96	
+3,5	100	100	100	100	100	69	100	85	100	56	100	41	87	57	100	42	100	33	100	26	90	
+3,0	100	100	100	100	100	65	100	79	100	52	100	39	82	53	100	39	100	30	100	24	84	
+2,5	100	100	100	100	100	61	100	74	100	49	100	36	76	50	100	36	100	28	95	22	78	
+2,0	100	100	100	100	100	56	100	69	100	45	95	33	71	46	100	34	100	26	88	21	72	
+1,5	100	100	100	100	100	52	100	63	100	42	87	31	65	42	100	31	100	24	81	19	67	
+1,0	100	100	96	100	100	47	100	58	100	38	80	28	60	39	100	28	94	21	74	17	61	
+0,5	100	100	87	100	100	43	96	52	99	34	73	25	54	35	100	25	85	19	67	15	55	
Nozzle cap.	2,5 kg/h		5,0 kg/h			10 kg/h		20 kg/h		30 kg/h		40 kg/h		60 kg/h		80 kg/h		100 kg/h		120 kg/h		

Tank at the same level or below the burner

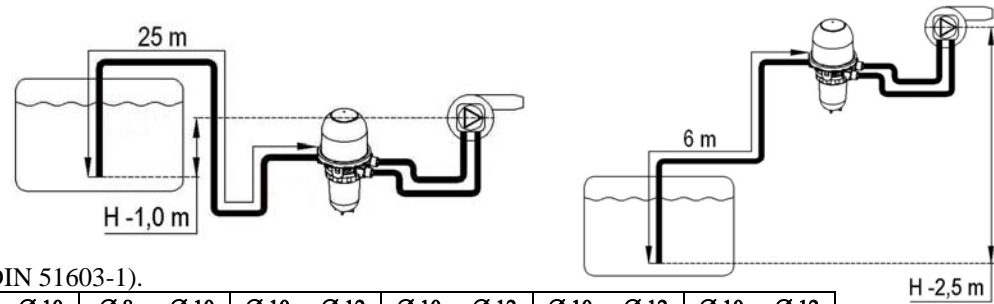

This table is valid for **standard fuel oil** with a viscosity of 6,0 mm²/s (cSt) (DIN 51603-1).

Height in m	Ø4 Inner mm	Ø5 Inner mm	Ø4 Inner mm	Ø5 Inner mm	Ø6 Inner mm	Ø5 Inner mm	Ø6 Inner mm	Ø6 Inner mm	Ø8 Inner mm	Ø8 Inner mm	Ø10 Inner mm	Ø8 Inner mm	Ø10 Inner mm	Ø10 Inner mm	Ø12 Inner mm	Ø10 Inner mm	Ø12 Inner mm	Ø10 Inner mm	Ø12 Inner mm	Ø10 Inner mm	Ø12 Inner mm	
	Max. pipe length in m																					
0,0	52	100	26	64	100	32	66	33	100	69	100	52	100	85	100	63	100	50	100	41	87	
-0,5	46	100	23	56	100	28	58	29	92	61	100	45	100	74	100	55	100	44	92	36	77	
-1,0	39	97	19	48	100	24	50	25	79	52	100	39	97	64	100	48	100	38	80	31	66	
-1,5	33	81	16	40	84	20	42	21	66	44	100	33	81	54	100	40	84	32	67	26	55	
-2,0	27	66	13	33	68	16	34	17	54	36	88	26	66	43	91	32	68	25	54	21	44	
-2,5	20	50	10	25	52	12	26	13	41	27	67	20	50	33	69	24	52	19	41	16	34	
-3,0	14	35	7	17	36	8	18	9	28	19	47	14	35	23	48	17	36	13	28	10	23	
-3,5	8	19	4	9	20	4	10	5	16	10	26	7	19	12	27	9	20	7	15	5	12	
-4,0	1	4	0	2	4	1	2	1	3	2	5	1	4	2	5	1	4	1	2	0	2	
Nozzle Cap.	2,5 kg/h		5,0 kg/h			10 kg/h		20 kg/h		30 kg/h		40 kg/h		60 kg/h		80 kg/h		100 kg/h		120 kg/h		

This table is valid for **kerosene** with a viscosity of 2,15 mm²/s (cSt) 2800 min⁻¹.

Height in m	Ø4 Inner mm	Ø5 Inner mm	Ø4 Inner mm	Ø5 Inner mm	Ø6 Inner mm	Ø4 Inner mm	Ø5 Inner mm	Ø5 Inner mm	Ø6 Inner mm	Ø6 Inner mm	Ø8 Inner mm	Ø6 Inner mm	Ø8 Inner mm	Ø8 Inner mm	Ø10 Inner mm	Ø8 Inner mm	Ø10 Inner mm	Ø8 Inner mm	Ø10 Inner mm	Ø8 Inner mm	Ø10 Inner mm	
	Max. pipe length in m																					
0,0	100	100	78	100	100	39	96	47	99	65	100	48	100	100	100	76	100	60	100	49	100	
-0,5	100	100	69	100	100	34	85	42	88	58	100	43	100	91	100	68	100	53	100	43	100	
-1,0	100	100	61	100	100	30	74	36	77	51	100	37	100	80	100	59	100	46	100	37	96	
-1,5	100	100	52	100	100	26	63	31	66	43	100	32	100	68	100	50	100	39	100	32	82	
-2,0	100	100	43	100	100	21	53	26	54	36	100	26	86	56	100	41	100	32	83	26	68	
-2,5	87	100	34	85	100	17	42	20	43	28	92	21	69	45	100	33	83	25	66	20	54	
-3,0	65	100	26	64	100	12	31	15	32	21	69	15	51	33	84	24	62	18	48	14	39	
-3,5	43	100	17	42	88	8	21	10	21	14	45	10	34	21	55	15	40	11	31	8	25	
-4,0	21	53	8	21	44	4	10	4	10	6	22	4	16	10	27	6	19	4	14	2	11	
Nozzle Cap.	2,5 kg/h		5,0 kg/h			10 kg/h		20 kg/h		30 kg/h		40 kg/h		60 kg/h		80 kg/h		100 kg/h		120 kg/h		