

Shower Seat

Installation & User

Guide

Introduction

Important Points

The Mira shower seat has been designed for installation inside a shower cubicle, over a bath or within the drying area.

The shower seat must be secured to a flat, sound and solid wall surface ('solid' means constructed of brick or high density concrete block).

Warning! All 5 screws and wall plugs **MUST** be securely fitted to the full depth.

Warning! This product has been designed as a seat only and should not be used for any other purposes.

Note! The shower seat may be fixed to other wall types, but advice **MUST** be sought from a competent builder regarding wall structure and fastening prior to fitting.

Cavities, voids, loose material, cables and pipes **MUST** be avoided when locating the fixing screws.

Maximum Weight - **95.5 kg (15 stone)** evenly distributed about the seat.

Cleaning and Maintenance

Many household cleaners contain abrasive and chemical substances, and should not be used for cleaning plated or plastic fittings. These finishes should be cleaned with a mild washing up detergent or soap solution, and then wiped dry using a soft cloth.

Fixing Height

The fixing height of the shower seat depends largely on the height of the user, it will usually be somewhere between 450-550 mm above the bottom of the shower tray, bath or floor.

A simple method of determining the shower seat height would be to measure the seat height of the users favourite/most comfortable chair, and fix the shower seat at a similar height.

Pack Contents Checklist

☑ Tick the appropriate boxes to familiarise yourself with the part names and to confirm that the parts are included.

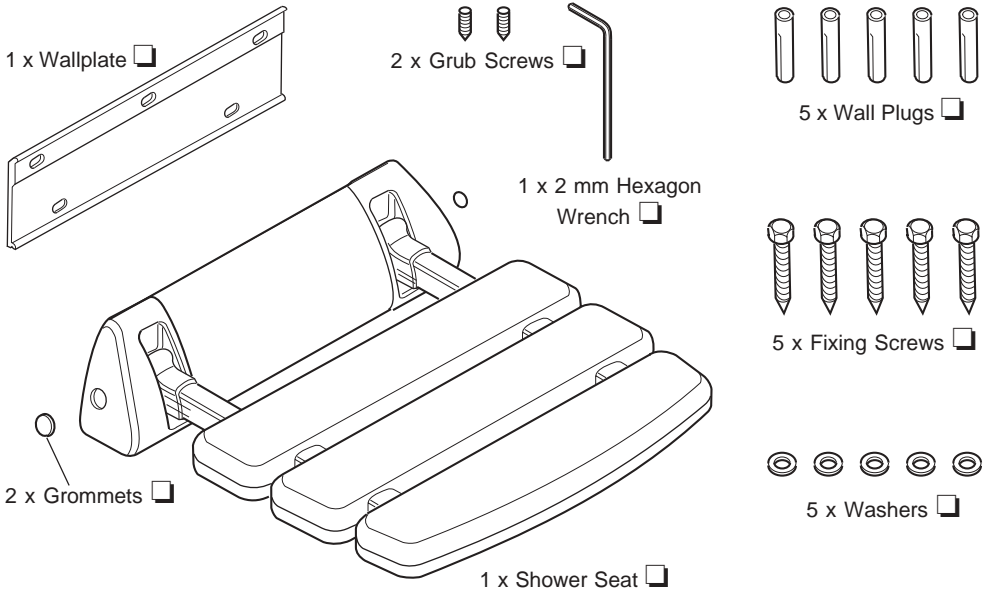

Dimensions

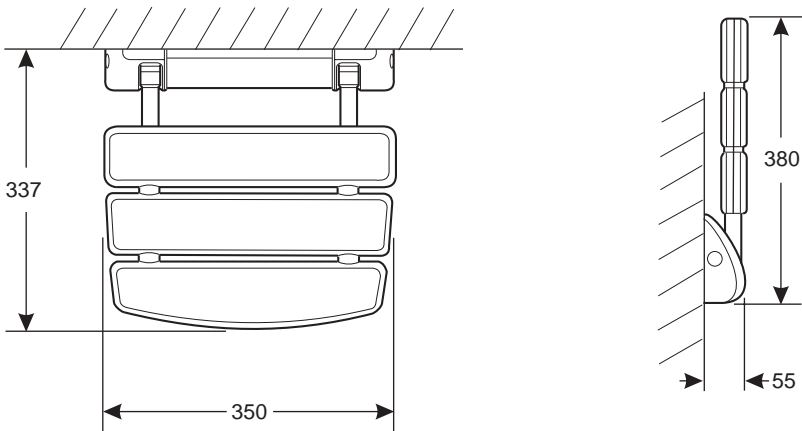

All dimensions are nominal and in millimetres

Figure 2

Installation

WARNING! AN INCORRECTLY FITTED SEAT MAY RESULT IN INJURY TO THE USER.

1. Place the wallplate against the wall, with the 3 screw holes at the top of the plate. Mark through the 5 screw holes, as shown in Figure 3.

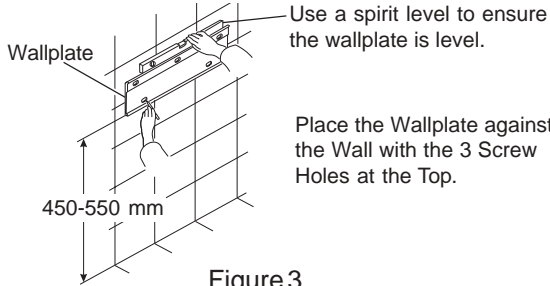

Figure 3

2. Drill 10 mm diameter holes and plug the wall, with the wall plugs provided. Fix the wallplate firmly to the wall with the screws and washers provided.

WARNING! Ensure there are no buried cables or pipes in the wall before drilling. The wall must be vertical and flat. All 5 screws and wall plugs must be securely fitted to their full depth.

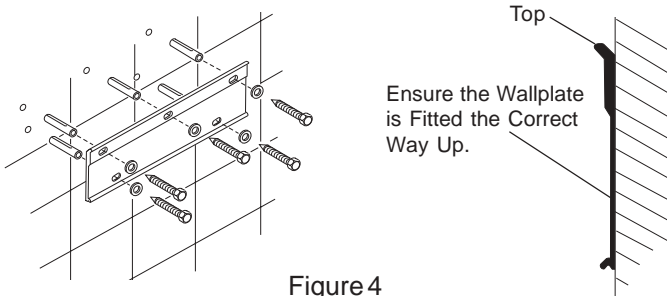

Figure 4

3. Fit the concealing plate over the wallplate. Ensure the top lip of the body sits on the top edge of the wallplate before securing the concealing plate and seat to the wallplate with the two grub screws provided (refer to Figure 5).

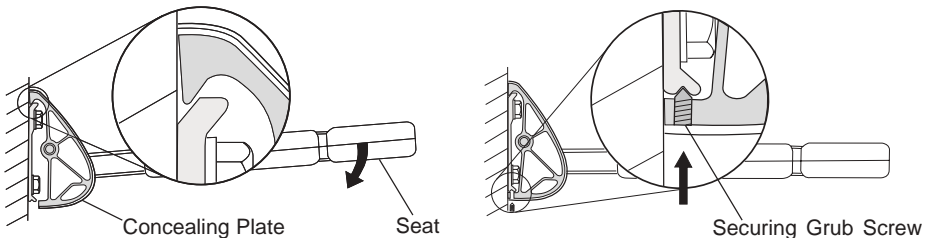

Figure 5

4. Check the seat pivots up and down freely.

Spare Parts

Part No. Description

935.82 Wallplate and Fixing Screws

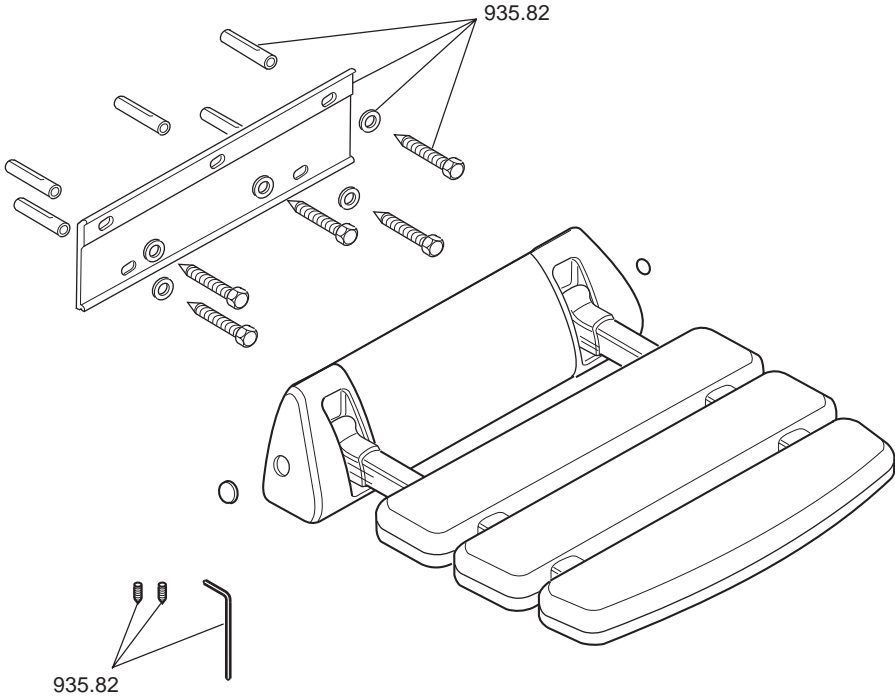

Notes

Customer Service

Guarantee of Quality

Mira Showers guarantee products against any defect of materials or workmanship for one year from the date of purchase (2 years for Mira Select and 3 years for Mira Excel ranges).

To validate the guarantee, please return your completed registration card.

Within the guarantee period we will resolve defects, free of charge, by repairing or replacing parts or modules as we may choose.

To be free of charge, service work must only be undertaken by Mira Showers or our approved agents in Northern Ireland and Republic of Ireland.

Service under this guarantee does not affect the expiry date. The guarantee on any exchanged parts or product ends when the normal product guarantee period expires.

Not covered by this guarantee:

Damage or defects arising from incorrect installation, improper use or lack of maintenance, including build-up of limescale.

Damage or defects if the product is taken apart, repaired or modified by any person not authorised by Mira Showers or our approved agents.

This guarantee is in addition to your statutory and other legal rights.

Before using your shower

Please take the time to read and understand the operating and safety instructions detailed in this manual.

What to do if something goes wrong

If when you first use your shower it doesn't function correctly, first contact your installer to check that installation and commissioning are satisfactory and in accordance with the instructions in this manual. We are on-hand to offer you or your installer any advice you may need.

Should this not resolve the difficulty, simply contact our Customer Services who will give every assistance, and if necessary arrange for our service engineer to visit.

If later the performance of your shower declines, consult this manual to see whether simple home maintenance is required. Please call our Customer Services to talk the difficulty through, request service under guarantee if applicable, or take advantage of our comprehensive After-Sales service.

As part of our quality and training programme calls may be recorded or monitored

After Sales Service

Our Customer Services Team is comprehensively trained to provide every assistance you may need: help and advice, spare parts or a service visit.

Spare Parts

We maintain an extensive stock of spares, and aim to have functional parts available for ten years from the date of final manufacture of the product.

Spares can be purchased from approved stockists or merchants (locations on request) or direct from Customer Services.

Spares direct will normally be despatched within two working days. Payment can be made by Visa or Access at the time of ordering. Should payment by cheque be preferred a pro-forma invoice will be sent.

Note! In the interests of safety, spares requiring exposure to mains voltages can only be sent to competent persons.

Service

Our Service Force is available to provide a quality service at a reasonable cost. You will have the assurance of a Mira trained engineer/agent, genuine Mira spares – and a 12 month guarantee on the repair.

Payment should be made directly to the Service Engineer/Agent, using Visa, Access or a cheque supported by a banker's card.

To contact us:

England, Scotland & Wales

Mira Showers Customer Services

Telephone: 01242262888
8.30am to 5pm Working days (4.30pm Fri)
8.30 am to 12.30pm Saturday
E-mail: Mira_technical@mirashowers.com

Fax: 01242282595
By Post: Cromwell Road
Cheltenham
Gloucester GL52 5EP

For Customers in Northern Ireland

Wm H Leech & Son Ltd

Telephone: 028 9044 9257 – Mon to Fri 9 am-5pm
Fax: 028 9044 9234 – 24 hours
Post: Maryland Industrial Estate
Ballygowan Road
Moneyreagh, Co Down
BT23 6BL

For Customers in Republic of Ireland

Modern Plant Ltd

Telephone: Dublin 01 4591344 - Mon to Fri 9am to 5pm
Fax: Dublin 01 4592329 – 24 hours
Post: Otter House
Naas Road
Clondalkin
Dublin 22

Mira Showers

Kohler Mira Ltd
Cromwell Road,
Cheltenham GL52 5EP.

Mira is a registered trade mark.
The company reserves the right to alter product specifications without notice.

www.mirashowers.com



BS EN ISO 9001 : 1994
Reg. No. FM 14648

mira
SHOWERS