



Vessel Jet



Premier Range



Stove Performance



Oil



Analysers



Report Pads



Stickers



Bits'n'Bolts



Compact



Temperature



Stove Efficiency



Leak Detection



Moisture



Water Treatment



Pressure



Bespoke Products



Intelligent Tools



360° Illumination

Regin

www.regin.co.uk

Regin

www.regin.co.uk

NEW



BRAND NEW website:
www.regin.co.uk

Regin Products Ltd
8-12 Tower Square
Huntingdon
Cams
PE29 7DT
www.regin.co.uk

TOOLS

Flow & Pressure	6
Vessel Jet, Manometers, Manometer Fluid, Tubing, Radvalve Change Kit etc	
Gas Detection	22
Analyser, Sniffa, CO Detection etc	
Plumbing Hand Tools	30
Socket Set, Wrenches, Pipe Cutters, Trimming Knife, Pliers, Hex Key etc	
Electrical Hand Tools	39
Insulated Screwdrivers, Insulated Pliers, Insulated Cutters etc	
Electrical	44
Multimeters, Voltage Detectors, Safety Test Plug, Circuit Breaker etc	
Specialist Tools	49
AAV Removal Tool, Volt Testers, Inspection Mirrors, Ventilation Calculation Tools etc	
Lamps & Torches	53
Inspection Lamps, LED Lights, Torches etc	
Thermometers	56
Thermometers, Multi Thermometers, Infra Red Thermometers, Probes etc	
Brushes & Abrasives	60
Bespoke Brushes, Cleaning Blades, Steel Wool, Carbide Strips etc	
Part P Test Equipment	65
Part P Test Kit, PAT Test Units, Test Leads etc	
Miscellaneous	70
Bungee Straps, Contour Turner, Magnetic Dish etc	

CONSUMABLES

Smoke	72
Smoke Pellets, Smoke Matches etc	
Tapes	76
ID Tapes, Foil Tape, Boiler Case Seal, Foam Tapes, PTFE Tapes etc	
First Aid & Fire	82
First Aid Kits, Fire Extinguishers etc	
Report Pads	83
Inspection Pads, Service Pads, Advice Notice Pads, Commercial Pads, etc	
Stickers & Tags	90
Warning Stickers & Tags, Advice Stickers, Service Stickers etc	
Electrical Stickers & Tags	94
Warning Stickers & Tags etc	
Marker Pens	96
Paint Marker Pens	
Location Plates	97
Plastic Location Plates	
Solder Mats	98
Heat Dissipating Flame Retardant Spray, Solder Mats	
Kits	99
Appliance Servicing Kits, Fuse Kits, Olive & Washer Kits etc	
O-Ring Kits	102
Imperial & Metric Nitrile O-Ring Kits	
Service Aerosols & Paints	104
Air Dusters, Cleaning Spray, Silicone Spray, Adhesive, Coal Paint etc	
Leak Detection	106
Leak Detector Aerosol, Leak Detector Sprays	
Sealants etc	107
Silicone Sealants, Silicone Grease, Heat Sink Compound etc	
Inspection Hatches	112
Inspection Hatches, Fire Rated Hatches	
Glass Yarn & Fixative	113
Glass Yarn, Glass Yarn Adhesive	
Gloves	114
Work Gloves, Latex Gloves, Vinyl Gloves, Nitrile Gloves, Heat Resistant Gloves etc	

CONSUMABLES cont...

Dust Sheets	117
Dust Sheets, Service Mats, Work Mats etc	
Wipes & Work Wear	120
Paper Towel, Hand Wipes, Dust Masks, Safety Goggles etc	
Batteries	122
Alkaline Batteries	
Spares	124
Safety Connectors, Radiator Tops, Ignition Leads, Relays etc	

STOVE RANGE

Stove Range	129
A comprehensive range of products specifically designed for use on wood or multi-fuel stoves, grates, flues etc	

BITS 'n' BOLTS

O-Rings	138
Imperial & Metric Nitrile O-Rings	
Washers	140
Fibre Washers, Pump Washers, Steel Washers etc	
Spire Nuts	144
Spire Nuts, Control Knob Clips etc	
Nuts	145
Brass Nuts, Wing Nuts, Thermocouple Split Nuts etc	
Fuses	146
Quick Blow Fuses, Anti-Surge Fuses etc	
Miscellaneous	147
Pressure Test Nipples, Knife Blades, Radiator Keys, Cable Ties, Superglue, etc	
PCB Support Posts	152
Printed Circuit Board Support Posts	
Screws	153
Pan Screws, Self Tapping Screws	
Electrical Connectors	154
Push-In Connectors, Pre-Insulated Terminals, Connector Strips etc	
Tapes & Labels	158
PVC Insulation Tapes, Pipe Labels	
Olives	159
Brass Olives	

OIL

Testing	162
Pressure Gauges, Test Kits etc	
Miscellaneous	164
Suction Pumps, Finding Pastes, Oil Hoses, Nozzle Spanner, Rajah Clips, etc	
Report Pads	169
Oil Report Pads	
Flared Fittings	170
Brass Flared Fittings, Flaring Tool	

Val-U-Trade	172
Point of Sale	174
Product Code Index	177
A - Z Index	183

Flow & Pressure Vessel Jet, Manometers, Manometer Fluid, Tubing, Radvalve Change Kit etc	6
Gas Detection Analyser, Sniffa, CO Detection etc	22
Plumbing Hand Tools Socket Set, Wrenches, Pipe Cutters, Trimming Knife, Pliers, Hex Key etc	30
Electrical Hand Tools Insulated Screwdrivers, Insulated Pliers, Insulated Cutters etc	39
Electrical Multimeters, Voltage Detectors, Safety Test Plug, Circuit Breaker etc	44
Specialist Tools AAV Removal Tool, Volt Testers, Inspection Mirrors, Ventilation Calculation Tools etc	49
Lamps & Torches Inspection Lamps, LED Lights, Torches etc	53
Thermometers Thermometers, Multi Thermometers, Infra Red Thermometers, Probes etc	56
Brushes & Abrasives Bespoke Brushes, Cleaning Blades, Steel Wool, Carbide Strips etc	60
Part P Test Equipment Part P Test Kit, PAT Test Units, Test Leads etc	65
Miscellaneous Bungee Straps, Contour Turner, Magnetic Dish etc	70



ON/OFF
Select
PSI/BAR/KPI



Pre Set Pressure
Adaptation Function
Auto-Off < 1min

Regin

Flow & Pressure

VESSEL

Professional Cordless
Pressure Vessel
Inflator

REGK01



Optional extras available:

REGK02 - Replacement / spare rechargeable battery for Vessel Jet

REGK03 - 12V cable adaptor (for continuous power), useful when topping up van tyres.

REGK29 - Regin angled adaptor for assistance in severely restricted access situations (see page 9).

REGK02



REGK03



Vessel Jet Pressure Vessel Inflator



The Regin Vessel Jet is a German designed professional hand held air compressor. It is an ideal tool for:

- Filling Pressure Vessels on Pressurised and Unvented Cylinder Systems (Average 8 litre pressure vessel inflate time: 1.5 bar in 1 minute).
- Topping up pressure in van tyres (A 175 R 14 Vehicle tyre inflates, on average, from 0 - 36 psi (2.5 bar) in 8 minutes.
- Inflation of bicycle tyres and sports equipment with the additional adaptors supplied.

The Regin Vessel Jet is easier to use than a hand or foot pump, especially in restricted areas.

Portable, versatile and durable, The Vessel Jet is the perfect travel companion for your mobile inflation requirements.

Vessel Jet includes:

- Ergonomic high pressure air compressor
- Built-in digital gauge with preset function in bar, psi or kpi
- Built-in LED light for pinpointing valve in dark locations
- Extended 75cm pressure hose with thread connector for secure fitting to schrader valve
- Preset Auto Stop at desired pressure
- Auto shut off if connection poor
- Instant pressure reading - ideal for 'topping up' pressure
- Back-lit digital display
- Rechargeable Li-ion Battery Pack (no memory effect)
- AC Charger for Li-ion Battery
- Travel carrying bag with spare compartment for extra battery
- Adaptors for balls and inflatable toys included



Average 8 litre pressure vessel inflate time: 1.5 bar in 1 minute from empty



Rechargeable Lithium-Ion Battery



Easy to read Illuminated Digital Display



Includes extended 75cm pressure hose with threaded connector

Flow & Pressure

REGK30**Pressure Vessel Hand Pump**

3 metre extended hose.

- For pressurising pressure vessels.
- Freestanding.
- 0 - 11 Bar (0 - 160 p.s.i.) barrel mounted gauge.
- 3 metre extended hose helps access difficult to reach pressure vessels.
- Durable steel barrel.
- Oversize barrel for high efficiency.

REGK35**Premier Pressure Vessel Hand Pump**

3 metre extended hose.

- For pressurising pressure vessels.
- High quality construction.
- *REGK29* Pressurisation Pump Angled Adaptor included free.
- Freestanding.
- Top-mounted gauge for easier reading.
- 0 - 11 Bar (0 - 160 p.s.i.) gauge.
- 3 metre extended hose helps access difficult to reach pressure vessels.
- 6063 Extruded aluminium barrel.
- Clever valve system with air-release button.

REGX10**Pressure Vessel-Checker**

- Digital Pressure Gauge.
- Suitable for easy checking of expansion vessel pressures.
- Reads pressure in PSI, Bar & KPA.
- Pressure range:
2-99 PSI, 0.15-7 Bar & 15-700 KPA.
- Can also be used for vehicle tyre pressure checks.
- Rubber grip finish.
- Auto shut-off.
- Illuminated display/nozzle.
- Supplied complete with batteries (*REGGAG13*).

See page 106 for Leak Detection Sprays and Fluids

Pressurisation Pump Angled Adaptor

For use with *REGK30* and *REGK35*

- Helps access those difficult to reach pressure vessel valves.
- Can also be used with *REGK01 Vessel Jet Inflator* and *REGX10 Digital Pressure Vessel Checker* (see page 8).

REGK29

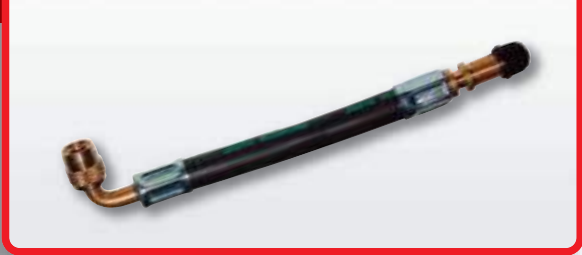

Pressurisation Pump Straight Adaptor

For use with *REGK30* and *REGK35*

- Helps access those difficult to reach pressure vessel valves.
- Can also be used with *REGK01 Vessel Jet Inflator* and *REGX10 Digital Pressure Vessel Checker* (see page 8).

REGK28



Pen Type Pressure Gauge

- Pen type gauge with chromed steel body and pocket clip.
- Scale from 6-50psi in 1psi graduations.
- Dust cap includes valve core removal tool.

REGK36



Schrader Valve Core

- 10 cores per pack.
- Genuine Schrader™ product.
- Nickel-plated brass.
- Teflon seal.
- Standard flow.



REGK33



Schrader Valve Core Screwdriver Tool

- Specialist tool for removing the core from Schrader valves.
- Genuine Schrader™ product.



REGK34



Flow & Pressure

REGU35**REGU40****Premier Gauge Manometer**

Premier manometers use higher density fluid than conventional water-filled gauges allowing reduced length and more compact design.

- A solid acrylic gauge in a tough metal casing.
- Easy zero adjustment and a clear accurate scale.
- Blue fluid for ease of reading in poorly lit locations.
- Trap chambers reduce the possibility of fluid loss through spillage or overpressure.
- Suitable for Natural Gas and L.P.G. readings.
- Hanging slot and strap.
- Supplied in a nylon protective bag.
- **Please note:**
use only 1.88 SG fluid (**REGU70**).
- Comes pre-filled with fluid.
- Spares available, see bottom of this page.



- **Available in two sizes:**

- **REGU35 - Premier 45 Gauge Manometer**

- Measures to 18in.w.g. or 45 mbar.
- Overall length - approx. 18" (450mm).

- **REGU40 - Premier 60 Gauge Manometer**

- Measures to 24in.w.g. or 60 mbar.
- Overall length - approx. 22" (560mm).

Spares available:

- **REGU36** - Premier Gauge Stopper
- **REGU38** - Premier 45 (**REGU35**) Screw & 'O' Ring Set
- **REGU39** - Premier 45 (**REGU35**) Nylon Bag
- **REGU41** - Premier 60 (**REGU40**) Nylon Bag
- **REGU42** - Premier 60 (**REGU40**) Screw & 'O' Ring Set



See page 106 for Leak Detection Sprays and Fluids

Premier Fluid

5ml

- Fluid has a specific gravity of 1.88 SG.
- *Exclusively for use in Regin Premier Gauges (REGU35 & REGU40 - see opposite).*
- Contents: 5ml (enough to completely refill a Premier 45 - REGU35)



REGU70



'J' Gauge

- Reduced overall length for easy use.
- Supplied complete with unique 1.99 SG fluid (REGU31), (only this fluid can be used).
- Levels are indicated by a floating ball in a liquid column.
- Trap chambers help minimise loss of manometer fluid.
- Use only 1.99SG fluid (REGU31).



- **Available in two sizes:**
- **REGU30 - 48"/120mbar 'J' Gauge**
- Overall length - approx. 32" (810mm).
- **REGU32 - 60"/150mbar 'J' Gauge**
- Overall length - approx. 38" (960mm).

REGU30



REGU32

'J' Gauge Fluid

10ml

- Fluid has a specific gravity of 1.99 SG.
- Exclusively for use in Regin 'J' Gauges (REGU30 & REGU32 - see above).



REGU31



Contract 'U' Gauge

- PVC 'U' tube.
- Sliding scale for easy zero.
- Key-hole suspending slot.
- Use 1.00SG fluid (REGU45 - see page 12).



- **Available in two sizes:**
- **REGU05 - Contract '30' - 12in.w.g/30mbar gauge**
- **REGU25 - Contract '60' - 24in.w.g/60mbar gauge**
Suitable for Natural Gas and L.P.G. readings.

REGU05



REGU25

See page 106 for Leak Detection Sprays and Fluids

Flow & Pressure

REGU10**12" 'U' Gauge**

- Measures up to 12in.w.g or 30 mbar. on dual scale.
- 'U' tube made from perspex.
- Built-in stand for hands-free use.
- Suction cup.
- Sliding scale for easy zero.
- Use 1.00SG fluid (REGU45 - see below).

**REGU15****18" 'U' Gauge**

- Measures up to 18in.w.g or 45 mbar. on dual scale.
- 'U' tube made from perspex.
- Built-in stand for hands-free use.
- Suction cup.
- Sliding scale for easy zero.
- Suitable for Nat. Gas and L.P.G. readings.
- Use 1.00SG fluid (REGU45 - see below).

**REGU20****24" 'U' Gauge**

- Measures up to 24in.w.g or 60 mbar. on dual scale.
- 'U' tube made from perspex.
- Suction cup.
- Sliding scale for easy zero.
- Suitable for Nat. Gas and L.P.G. readings.
- Use 1.00SG fluid (REGU45 - see below).

**REGU45****Manometer Fluid**

22ml

- Fluid has a specific gravity of 1.00 SG (the same as water).
- Dyed blue to improve visibility.
- For use in all Regin 'U' Gauges (except for *REGU30*, *REGU32*, *REGU35* & *REGU40*).



See page 106 for Leak Detection Sprays and Fluids

Rubber Tube - 2m pack

2m pack

- 6mm internal diameter.
- For use with all Regin 'U' gauges.
- Suitable for use with Natural Gas.
- Temperature range: approx -65°C to +70°C.

REGU50



Rubber Tube - 18m coil

18m coil

- 6mm internal diameter.
- For use with all Regin 'U' gauges.
- Suitable for use with Natural Gas.
- Temperature range: approx -65°C to +70°C.

REGU55



Neoprene Tube - 2m pack

2m pack

- 6.5mm internal diameter.
- For use with all Regin 'U' gauges.
- Suitable for use with Natural Gas and L.P.G.
- Temperature range: approx -40°C to +100°C.

REGU60



Neoprene Tube - 18m coil

18m coil

- 6.5mm internal diameter.
- For use with all Regin 'U' gauges.
- Suitable for use with Natural Gas and L.P.G.
- Temperature range: approx -40°C to +100°C.

REGU65



Silicone Tube - 2m pack

2m pack

- 4mm internal diameter.
- Temperature range: approx -70°C to +200°C.

REGU68



Silicone Tube - 18m coil

18m coil

- 4mm internal diameter.
- Temperature range: approx -70°C to +200°C.

REGU69

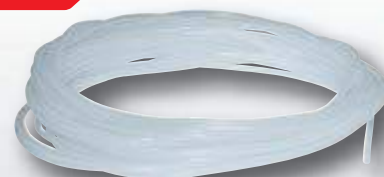

Flow & pressure

REGU77**Standard Pressure Relief Kit**

- Set the correct let-by and tightness test pressure on your manometer.
- No need to repeatedly remove hose to make pressure adjustments.

REGU78**LPG Pressure Relief Kit
inc. Valve Adaptor**

- Complete with connector for most modern LPG regulators.
- Set the correct let-by and tightness test pressure on your manometer.
- No need to repeatedly remove hose to make pressure adjustments.

REGU80**Pressure Test Kit Complete**

- Comprising a hand pump, short length of rubber tube, brass pressure test tee and a 1/4" BSP (F) x 15mm compression straight adaptor.
- This kit is required to pressurise and check the tightness of gas supply pipes in conjunction with a 'U' gauge (see pages 10-12).
- Supplied in strong nylon zip bag.

See page 106 for Leak Detection Sprays and Fluids

MRT Manometer Rigid Tube

- A rigid extension to Manometer tubing allowing the engineer to take gas pressures in a faster and more efficient manner.
- Best Boiler Engineer bespoke tool developed for many years.
- Connects immediately to tapered gas nipples on a boiler's gas valve.
- Excellent for all Boilers especially BBU's.
- Supplied with 1 metre length of rubber tubing.

Instead of fiddling around trying to find the tapered gas nipple on a boiler's gas valve, which is often set way back in the depths of the unit, you simply attach your manometer tubing to the M.R.T. Therefore providing a rigid platform which then connects to the gas valve. The product saves endless time and hassle allowing the engineer to do his job more efficiently and effectively.

- **Available in two versions:**

REGU03 - MRT Manometer Rigid Tube Standard (Straight)

REGU04 - MRT Manometer Rigid Tube 90° Degree

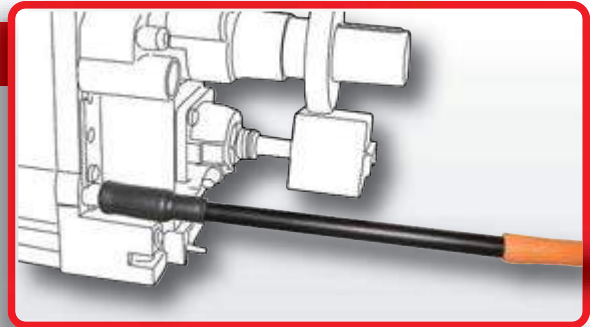

Gas Test Nipple Adaptor

- A unique adaptor that screws into a standard test nipple to eliminate the difficulties of attaching a rubber hose.
- An 'O' ring on the adaptor creates an effective seal.
- This unique product will save on working time and pay for itself very quickly.
- Supplied with a length of neoprene hose and in-line connector.

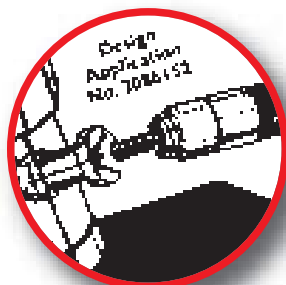

Flow & pressure

REGK10



Dry Pipe Pressure Test Kit

- Assists the testing of pipework at the carcassing stage.
- Kit comprises:
 - Cordless pump with Lithium Ion rechargeable battery (See *REGK01* - pages 6&7).
 - Spare Lithium Ion rechargeable battery.
 - Mains charger.
 - Pressure manifold.
 - Pressure gauge.
 - Pressure control valve.
 - 15mm Speedfit connector.
 - 22mm Speedfit connector.
 - Book of certificates.
 - Instruction manual.
- All supplied in a padded carry case.

REGU75



Brass Pressure Test Tee

- For use when testing tightness.

REGU83



Stopwatch

- For tightness and other timed tests.
- Normal time and alarm functions.
- 1/100-second accuracy with lap counter.

See page 106 for Leak Detection Sprays and Fluids

Radvalve Change Kit

- Used for changing radiator valves without draining down.
- The kit comprises of 2 patented rubber bungs, key pattern fixing clip and a radiator air bleed key.
- Supplied in strong nylon zip bag.
- See *REGR01* & *REGR10* (page 18) for details of associated useful products.
- For use on 15mm & 22mm pipework.

REGR05

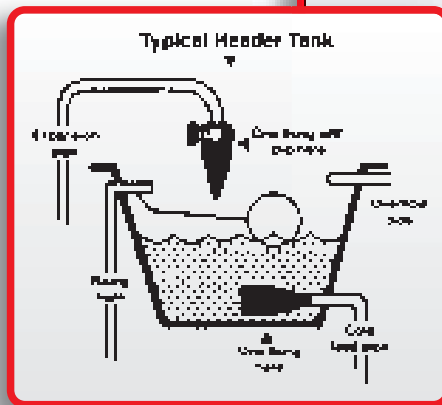

Drain-Down Hose Kit

10m length of rubber hose

- Internal diameter: 1/2", outer diameter: 3/4".
- Complete with jubilee hose clip c/w wing screw.
- Supplied with velcro 2 x 'tidy-straps' for neat coiling.

REGR09



Flow & pressure

REGR01**Draineasy Radiator Draining Kit**

- Move Radiators Fast!
- Avoid unnecessary mess.
- For professional or DIY use.
- Universal application for 8mm, 10mm, 15mm & 22mm pipework.
- Can be used in conjunction with *REGR05* (see page 17).
- Kit comprises:
 - 4 x Water Diverting Collars for 8mm, 10mm, 15mm and 22mm pipework,
 - Reusable Sealing Strips, Draining Tray and Water Resistant Barrier Gel (sufficient for 6-8 applications).

REGR50**Mains Water Pressure Test Kit**

- Easy to use.
- Kit comes complete in a zip bag with an 11 bar/160 p.s.i gauge and a flexible stainless steel braided hose, fitted with a 3/4" B.S.P. Female nut.
- For use on washing machine tap, bib tap or sink tap with adaptor (see *REGR51* below).

REGR51**Tap Adaptor**

- Tap adaptor for *REGR50*.

REGR10**Radtrap Drainage Pad**

- Quick easy method of channelling radiator contents into a suitable container, minimising spillage.
- Withstands hot water and chemical additives.
- Supplied with fixing clip.
- Can be used in conjunction with *REGR05* (see page 17).

Flow Cup

- For measuring water flow rate.
- Dual scale reading of 1 to 5 gallons and 2 to 25 litres per minute.
- Fold away handle.

REGM30



Therma-FloCup

- For measuring water flow rate.
- Measures both temperature and flow.
- Suitable for Benchmark testing.
- Splashguard to protect hands from hot water.
- Dual Scale - 1/2 to 5 gallons per minute and 2 to 23 litres per minute.
- Integrated digital thermometer. -50°C to +150°C (REGM32).
- Can be adjusted for left or right hand use.

REGM31



Waterproof Stem Thermometer

- Replacement thermometer for REGM31.
- 133mm Stainless steel probe.
- Measurement range: -50°C to +150°C.
- Switchable °F/°C.
- Auto Power Off.
- Hold function.
- Max/Min function.

REGM32



Waterproof



Dual Temperature



Auto Power Off



Quick Measurement



Accurate



Easy Operation



Stainless Sensor Probe

Flow & pressure

REGXE31



Digiman Diff Manometer

Differential Digital Manometer

Ideal for measuring gas supply pressures, burner pressures and even the differential pressures across fan interlock switches.

- Pressure range -200 to +200 mbar.
- Suitable for differential and standard readings.
- Large easy to read digital display.
- Suitable for Natural and L.P.G.
- 8 user selectable scales.
- Temperature compensated.
- One button zeroing.
- Long battery life.
- Robust case with integrally moulded protective boot.
- Integral magnets for hands free operation.
- Supplied with carry case, length of neoprene tubing, calibration report, battery and manual.

Specifications:

Scale	Range	Highest Resolution
Mbar	± 200	0.01
Pa	± 9999	1
hPa	± 200	0.01
kPa	± 20	0.001
PSI	± 3.0	0.001
mm Hg	± 150	0.01
mm Wg	± 2100	0.01
In Wg	± 80	0.01
Accuracy	±0.5 mbar ±0.5% of reading whichever is greater	
Dimensions: Weight	295 grams with battery	
Handset	160mm x 80mm x 40mm (180mm including spigots)	
Ambient Operating Range	+0°C to +45°C 10% to 90% RH non-condensing	
Power Supply	9 volt PP3 alkaline battery	
Battery Life	Greater than 250 hours continuous operation with a 9 volt PP3 alkaline battery	
Max. Overrange	1000 mbar	



200
mbar

±200 mbar
Range



Large
Display



Suitable for
Nat. Gas
& LPG



Calibration
Certificate
Included



Long
Battery
Life



Integral
Magnet



Carry Case
Included



Tubing
Supplied

See page 106 for Leak Detection Sprays and Fluids

Ultra-man Manometer

Differential Digital Manometer

- Resolution to 0.003 mbar.
- Switchable between high and low resolution.
- Switchable between mbar, Pa, hPa, kPa, mmHg, mmH₂O, inH₂O and PSI.
- Data hold and max/min recording.
- Automated Tightness Testing.
- Infra-red optional printer available (REGXA55 see page 23).
- Temperature compensated for superior accuracy.
The Regin Premier Ultra-man is temperature compensated to minimise the "drift" in readings which can occur when electronic manometers are subject to temperature changes, e.g. when taken from a cold van into a warm building.
- Manual logging and auto logging.
The Ultra-man can log up to 250 readings manually or automatically. The user can adjust the logging interval.
- Let-by, Stabilisation and Tightness Tests
The Ultra-man can perform timed Let-by, Stabilisation and Tightness Tests which are automatically logged in the memory. The user can adjust the duration of each test.
- Printouts
The Ultra-man has an infra-red output to an optional printer, (REGXA55 - see page 23). 'Live', 'held' and 'logged' readings can be printed. Printouts include date, time and a 'header' which can be set by the user.
- The Regin Premier Ultra-man has an integral protective boot which contains a powerful limpet magnet.
- Supplied with carry case, length of neoprene tubing, calibration report, battery and manual.

REGX32

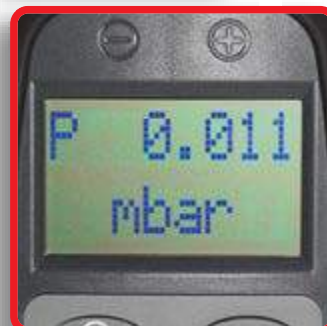

Specifications:

Nominal Pressure Range	Measure Range	Resolution	Accuracy
± 160 mbar	± 0.2 mbar	0.003 mbar	± 0.02 mbar
	± 19.999 mbar	0.003 mbar	± 0.05 mbar
	± 160 mbar	0.01 mbar	± 3% of reading
Parameter	Description		
Dimensions: Weight	295 grams with battery		
Handset	160mm x 80mm x 40mm (180mm including spigots)		
Ambient Operating Range	+0°C to +45°C 10% to 90% RH non-condensing		
Power Supply	9 volt PP3 alkaline battery		
Max. Overrange	5 times nominal range		

Gas Detection

REGXA455

Premier Ulti-mate Analyser

Boiler Analyser with direct CO₂ measurement

- Easy to use rotary dial.
- 5 year sensor life.
- Compact boiler analyser with high accuracy pressure readings.
- Four line display controlled by 9 position rotary switch.
- Measures O₂, CO₂ & CO (0 - 2,000 ppm).
- Differential pressure and differential temperature.
- Calculates CO/CO₂ ratio, excess air and efficiency for multi-fuel, gaseous fuels and light oils (28/35 sec).
- Infra-red output to optional printer (REGXA55 - see opposite). Print separate reports for combustion, pressure, let-by/tightness, temperature and room CO build up.
- "Send" button for instant printout and logging.
- Internal memory holds: 99 Combustion tests, 20 Pressure tests, 20 Tightness tests, 20 Temperature tests, 20 Room CO tests.
- Supplied in protective rubber boot with integral magnets for "hands free" use.
- Multi-fuel: Natural Gas, Propane, Butane, LPG, Light Oils (28/35 sec) and wood pellets.
- Designed to meet BS7927, BS7967 and EN50379.
- Supplied with:
 - Flue probe
 - 4 x NiMH rechargeable batteries and charger
 - 2 x pressure fittings
 - Instruction manual
 - Supplied in a bespoke soft carry case



Analyser Infra-Red Printer

- Rugged, battery powered printer fitted with protective rubber sleeve with integrated strong magnet.
- Uses thermal paper instead of messy ink or ribbon.
- Compatible with many handheld analysers with infra-red output including the Regin *REGXA455* Premier Ulti-mate analyser and also the Regin *REGX32* Ultra-man digital manometer.
- Uses 4 x AA batteries
- Battery life approx. 6000 print line of continuous printing.
- Optional mains adaptor.
- Automatic power down (when using battery power).
- Power on indicator light.
- Print contrast switch.

REGXA55



Thermal Printer Rolls

5 per pack

- For use with REGXA55 Analyser Infra-Red printer.

REGXA56

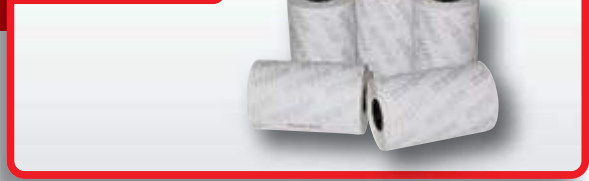

Analyser Appliance Sampling Probe Kit

- The REGXA8 Appliance Sampling Probe Kit enables the investigation of fumes/products of combustion from appliances such as cookers, grills, flueless appliances as described in BS 7967:2005.
- Each of the three probes can be fitted onto the hose/handle assembly using the compression fittings supplied.
- The kit is compatible with the Regin *REGXA1* One-Click Ratio Analyser, the Regin *REGXA455* Ulti-mate Analyser and also most other electronic combustion gas analysers.
- The kit comprises:
 - Grill probe with oval supports and 7 sampling holes over a 250mm sampling length.
 - Right-angled multihole probe with 5 sampling holes over a 125mm sampling length.
 - Straight open-ended probe, 325mm long.
 - 2 metre hose with handle and compression fitting.

REGXA8

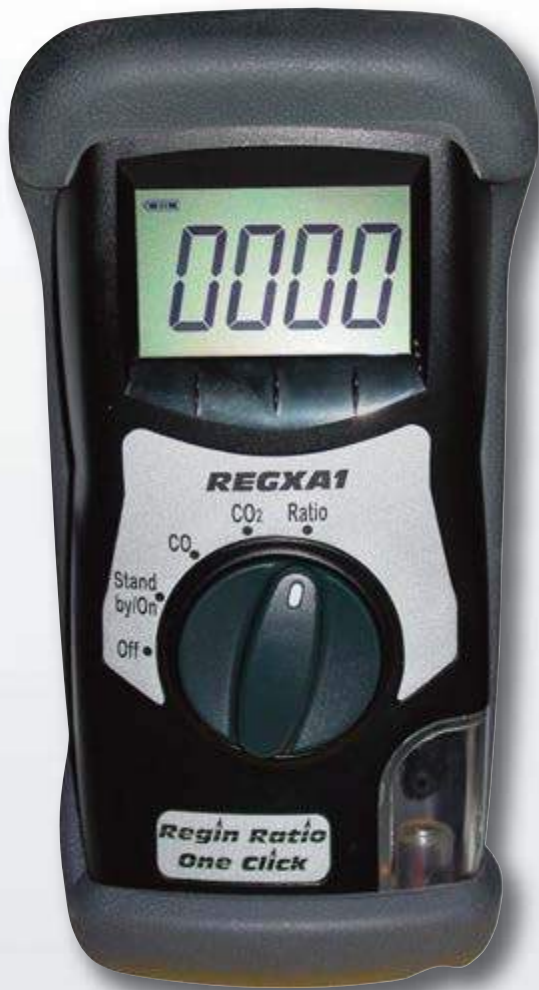

Gas Detection

REGXA1**One-Click Ratio Analyser**

- First year recalibration, service, extended 12 month warranty & calibration certificate renewal £59 +VAT.*
- Meets the requirements of BS 7967.
- 5 year sensor life.
- Direct to use - one-click function.
- Suitable for use with all common 'domestic' fuels including Natural Gas, Propane, Butane, LPG & Light Oil.**
- Integral water trap.
- Supplied with calibration certificate.
- 12 months warranty (extended for a further 12 months on annual recalibration).
- Supplied with probe, batteries and instructions.
- Storage cases available (REGXA6 & REGXA7).
- Supplied in protective rubber boot with integral magnet.
- Analyser readings record pad, sticker and annual service reminder enclosed (50 copies in duplicate per pad)(REGP80).
- Replacement filters available (REGXA5).
- Ratio shown to 4 decimal places.***

* For all REGXA1's purchased before 30-06-2016.

** When used with oil burning appliances the flue gases should only be sampled after the smoke level has been measured and has been confirmed to be a very low smoke number.

*** Ratio is shown to four decimal places but without a decimal point, so 0001 on the display is equivalent to 0.0001.



Analyser Readings Record Pad

50 copies in duplicate

- Top copy is self adhesive.
- Also acts as an Annual Service Reminder.

REGP80



Analyser Case - Large

- Large protective case for *Regin* Analysers (including probe).

REGXA6



Analyser Case - Small

- Protective case for *Regin* Analyser.

Please note; Analyser Probe will not fit inside this case.

REGXA7



Analyser Replacement Filter

- Replacement filter for *Regin* Analysers.

REGXA5



Easy Reach Analyser Probe Handle

- Extends to 3.5 metres.
- For use with *Regin* REGXA1 One-Click Ratio Analyser and *Regin* REGXA455 Ultimate Analyser & most other gas analysers.

REGXA3



Gas Detection



REGX39

Analysers Test Point Plug - Coaxial Wall

Coaxial

- Analysers test point plug.
- For dual walled flue.
- Provides permanent analyser probe access.



REGX38

Analysers Test Point Plug - Single Wall

Single Wall

- Analysers test point plug.
- For single walled flue.
- Provides permanent analyser probe access.



REGX75

Sniffa Plus

Sniffa Plus Gas Leak Detector

- Detects Methane, Natural Gas, Butane, Propane and other combustible gases.
- Gives both audible and visual signals.
- Tip light illuminates dark areas under test.
- 400mm long flexible probe.
- Supplied with protective rubber boot as standard.
- Adjustable sensitivity to pin-point leaks.
- One hand operation.
- Battery: 9V (6LR61).



Mobile CO

Carbon Monoxide Detector

The Regin Mobile CO monitors, records and alerts you to the presence of dangerous carbon monoxide in ambient air. The visual display constantly indicates precise quantities while the audible and visual alarms respond to various threshold levels.

- Extended sensor life - 5 years.
- Preset alarms:
- 3-colour warning light:
 - Green LED signals when CO is 2-9 ppm.
 - Yellow LED signals when CO is 10-29 ppm.
 - Red LED signals when CO is 30 ppm or higher.
- Audible alert at 30 ppm.
- MAX capture - continually updates highest CO reading.
- CO detection to 999 ppm.
- Auto zero activates upon turn on.
- Backlit display.
- Low battery indicator.

REGX01



Specifications:

Range:	0 - 999 ppm
Resolution:	1 ppm
Accuracy:	±3 ppm 0 to 100 ppm, ±5% reading > 101 ppm
Visual:	LCD and LED
Alarms - Visual:	Green 2 - 9 ppm Yellow 10 - 29 ppm Red 30 ppm or higher
Alarms - Audible:	Preset at 30 ppm.
Battery:	9V alkaline
Ambient Temp:	32°F to 104°F (0°C to 40°C)

Carbon Monoxide (CO) - is a lethal poison produced when certain fuels are burned. It can rapidly accumulate even in areas that might appear well ventilated. Because CO is colourless, tasteless, odourless and non-irritating, it can overcome an exposed person without warning. Recognising early warning signs of CO poisoning is sometimes difficult because early symptoms of CO exposure (headache, dizziness, nausea) are non-specific and may be mistaken for symptoms of other illnesses. A victim of CO poisoning may also become weak and confused and subsequently deprived of the ability to seek safety.

Gas Detection



Kidde 7yr Carbon Monoxide Alarm

- Kitemarked.
- EN50291-1:2010.
- Easy to fit and use.
- 7 year alarm life.
- Loud alarm, designed to alert you even as you sleep.
- Compact and easy to use.
- Battery operated (3 x AA supplied).



Kidde 10yr Carbon Monoxide Alarm

- Kitemarked.
- EN50291-1:2010.
- Easy to fit and use.
- 10 year alarm life.
- Loud alarm, designed to alert you even as you sleep.
- Compact and easy to use.
- Battery operated (sealed in Li-Ion battery).
- Sealed unit (fit and forget).



Kidde Compact Smoke Alarm

- EN14604:2005
- 3 year alarm life.
- Test button.
- Easy to fit and use.
- Flashing LED.
- Battery operated (1 x 9V 6LR61 supplied).

Smoke Alarm & CO Alarm Twin Pack

REGD12

- Home Safety Kit.
- Kidde 7yr Carbon Monoxide Alarm (See *REGD07* for spec - page 28).
- Kidde Compact Smoke Alarm (See *REGD15* for spec - page 28).
- Batteries supplied.



EI Carbon Monoxide Alarm - Battery

REGD25

- Advanced CO gas sensor is used for increased reliability and selectivity.
- Memory feature. Loud alarm.
- Easy to install and use.
- Test/silencer button.
- Tested to BSEN50291:2001.
- Power and alarm indicator lights.
- Battery powered (3 x AA supplied).



EI Carbon Monoxide Alarm - Plug In

REGD32

- Advanced CO gas sensor is used for increased reliability and selectivity.
- Memory feature. Loud alarm.
- Easy to install and use.
- Test/silencer button.
- Tested to BSEN50291:2001.
- Power and alarm indicator lights.
- Mains powered (230V).
- Fitted with 3 pin plug.



Plumbing Hand Tools



Appliance Micro Socket & Bit Set (1/4" Sq Drive) - 31 Piece

Kit contains:

- Bits:
 - Phillips: #1, #2, #3.
 - Pozi: #1, #2, #3.
 - Slotted: 4, 5, 6. Hex: 4, 5, 6.
 - TRX-Star: T10, T15, T20, T25, T27, T30.
- 1/4" Sq Drive Sockets: 4, 5, 6, 7, 8, 9, 10, 11, 12, 13mm.
- 50mm Extension Bar.
- 1/4" Sq Drive Ratchet Wrench.
- Bit Adaptor



**Appliance Micro
1/4" Sq Drive Ratchet Wrench**

Stainless Steel

- Manufactured from high quality stainless steel with a fully polished satin finish.
- 72-Tooth, ultra-smooth ratchet with slide reverse.
- Ideal for limited access applications.

9pc Colour Coded Stubby Combination Spanner Set

REGB57

6-14mm

- Drop-forged, Chrome Vanadium steel combination spanners.
- Hardened, tempered and chrome plated for corrosion resistance.
- Fully polished, colour coded finish for immediate size identification.
- Stubby size for ease of access and use in appliances.
- WallDrive® rings.
- Contents:
6, 7, 8, 9, 10, 11, 12, 13, 14mm



Premier Stumpy Adjustable Wrench

REGB51

- Reverse the jaws to convert from spanner to pipe wrench.
- One of the handiest tools in the bag.
- Features a shorter shaft than the standard wrench.
- Ideal for working in confined spaces.
- Features both metric and imperial scales for size reference.
- Features an ergonomic, larger width, soft grip handle for easier gripping and greater balance.
- Jaw capacity: 27mm.
- The ideal spanner/wrench for plumbers.



Extra Long Reach Screwdriver Set

REGB77

450mm long

- Set of two extra long reach screwdrivers: Pz2 x 450mm & 8mm (slotted) x 450mm.
- Hardened and tempered Chrome Vanadium steel shafts with a satin polished finish.
- Magnetized tips.
- Contoured handles with soft grips for comfort and control.



Plumbing Hand Tools



REGB90

Plumbers Swivel Back Pipe Saw

4 position frame

- 4-Position frame design offers large capacity cutting, plus three other positions suitable for working in areas where access is tight.
- Especially suitable for works engineers and plumbers although equally at home in the general workshop or DIY environment.
- Blade can be released and changed without the need for tools.
- Supplied with high carbon steel 300mm blade.

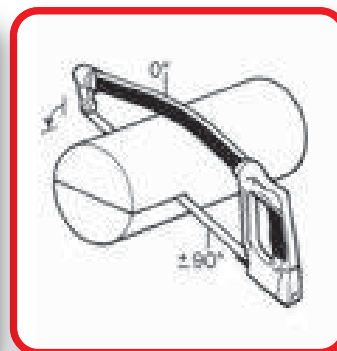
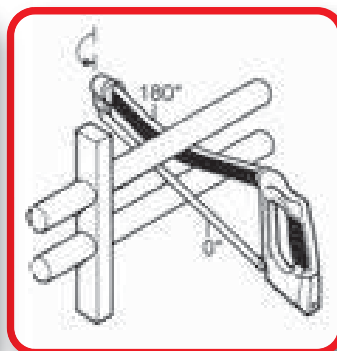
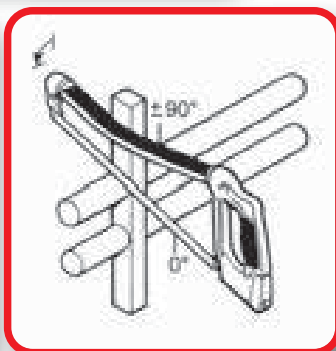
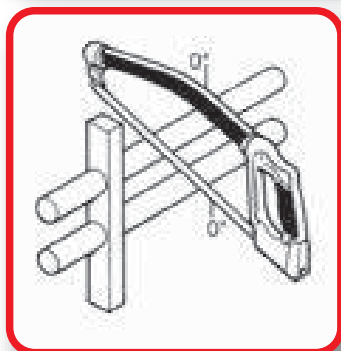

REGT50

Premier Retractable Trimming Knife

- Heavy duty construction.
- Reversible retractable steel blade.
- Very high quality.



REGM62

Mag Tip Magnetic Screw Holder

- Ideal for boiler hanging.
- Creates a strong, firm connection between screwdriver and screw.
- Can be fitted to most screwdrivers (with a shank diameter between 4.0 and 6.0mm or Phillips & Pozi sizes 1 & 2).
- Screw fastening becomes highly efficient, as the screw is firmly held, saving time and money.

15 Function Multi-Tool

- Manufactured from high quality stainless steel.
- Fully hardened and tempered for long life.
- Lightweight aluminium/composite handle construction.
- Multi-tool functions include: combination pliers, long nose pliers, wire cutter, fine edge blade, bottle opener, can opener, slotted screwdrivers, Phillips screwdriver, fish scaler, file, hook remover, ruler, wood saw and single/double file.
- Open/Closed length: 160mm/105mm.
- Ideal for camping and leisure activities.
- Supplied with belt pouch.

REGT04



Premier Water Pump Pliers

10" (25cm)

- Ratchet type.
- High quality German engineered.

REGB50



Water Pump Pliers - Groove Joint

10" (25cm)

- Chrome vanadium steel for long working life.
- Easily adjustable jaw opening.
- Double milled groove joint for extra grip and safety.
- Cushioned hand grips for comfort in use.
- Box jointed for ease of use and accuracy.
- 7 position jaw mechanism.

REGB49



Plumbing Hand Tools

REGB01

CuttaKeep™ Automatic Pipe Cutter Holder

The Regin CuttaKeep™ is a unique tool created to save you time and money. It will securely dock virtually any make of 15mm, 22mm and 28mm automatic pipe cutter and protect the cutter wheel from being damaged. It will also make routing around in the bottom of your toolbox a thing of the past - your automatic pipe cutters will be at your fingertips enabling you to find the required size in an instant.

The Cuttakeep™ also has a compartment where spare cutter blades can be stored.

- Organise your 15, 22 & 28mm automatic pipe cutters.
- Quickly & easily identify the correct size.
- Fits most brands.
- Store your replacement blades.
- Protects blade on new-style plastic pipe cutters.
- Helps protect your fingers.

Please note: Cutters are not included. See below for details on REGB02 CuttaKeep™ Kit.

REGB02

CuttaKeep™ Automatic Pipe Cutter Holder Kit

Kit includes:

- REGB01 - CuttaKeep™ Automatic Pipe Cutter Holder
- REGB39 - 15mm Autocut® Pipe Cutter
- REGB44 - 22mm Autocut® Pipe Cutter



Autocut® Automatic Pipe Cutter

- Professional quality cutter.
- Easy to use.
- Quick cutting of copper tubes.
- Self adjusting to pipes.
- Ensures a square even cut.
- Ideal for hard to reach places.
- Can be used one handed.
- Not to be used on stainless steel.
- Replacement cutter wheel available (see p150).

Sizes available:

- **REGB39** - 15mm
- **REGB44** - 22mm
- **REGB46** - 28mm

Plumbing Hand Tools

Insulation Stripper Pliers

6 1/4" (16cm)

- High quality German engineered.

REGB70



Mini Pipe Cutter

- For 3 - 22mm (1/8 - 7/8") tubes.

REGB05



Standard Tube Cutter

- For 3 - 30mm (1/8 - 1 1/8") tubes.

REGB10



Mini Tube Bender

- For 6, 8, & 10mm (1/4, 5/16 & 3/8") tubes.

REGB15



Hook & Pick Set

5 piece set

- Chrome vanadium steel.
- Ideal for replacing 'O' rings, marking your tools, removing small fuses or stuck parts etc.

REGK40



Plumbing Hand Tools



Hex Key Set

Set of 10 Hex Keys

- **Sets available:**
- **REGB33 - Metric Hex Key Set**
1.5, 2.0, 2.5, 3.0, 4.0, 5.0,
5.5, 6.0, 8.0 & 10.0mm keys.
- **REGB34 - Imperial Hex Key Set**
 $\frac{1}{16}$, $\frac{5}{64}$, $\frac{3}{32}$, $\frac{1}{8}$, $\frac{5}{32}$, $\frac{3}{16}$, $\frac{7}{32}$,
 $\frac{1}{4}$, $\frac{5}{16}$ & $\frac{3}{8}$ " keys.



T Handle Hexagon Key

Ideal for pumps

- **Sizes available:**
- **REGB32 - 4mm T Handle Hex Key**
- **REGB36 - 5mm T Handle Hex Key**



REGB21

Mini Crutch Stop Cock Key

- Access stopcock valves in awkward & difficult to reach locations.
- Adds extra leverage & reach.
- Fits stopcocks from $\frac{1}{2}$ " upwards.
- Hex shaft & removable tommy bar.
- Can connect to socket & ratchet handle.



REGB22

1000mm Combination Stop Cock Key

- Strong steel Stop Cock Key
- 1000mm long.
- For $\frac{1}{2}$ " & $\frac{3}{4}$ " stop cocks.
- Pointed handle for opening stop cock covers.



REGB19

4-Way Utilities Key

- Compatible with water, electric & gas service cabinets.
- All metal design.
- Durable Small and compact.

Radiator Key

- 1/2" with slotted end and 3/8" square end for vent plugs and bleed screws.

REGB20**Crowfoot Basin Wrench**

- To suit 1/2" and 3/4" taps.

REGB25**Immersion Spanner - Cranked**

- 2 1/4" cranked handle.

REGB30**Spring Loaded Basin Wrench**

- To suit 1/2" and 3/4" taps.
- 11" (275mm) shaft.

REGB35**Monobloc Back Nut Tap Spanner Set****6 piece set**

- Double ended box spanners for use on nuts in awkward or restricted locations.
- Set contains: 8/9mm, 10/11mm, 12/13mm, 14/15mm, 16/17mm and 18/19mm spanners.
- Tommy bar.

REGB26

Plumbing Hand Tools

REGB81



Premier Sealant Gun

- Suitable for use with all 310ml cartridges up to 220mm length including REGZ34, REGZ35, REGZ36 and REGZ37.
- Very strong construction (in order to deal with the high viscosity of our silicones and silicates).
- Includes tip cutter, just insert the nozzle of the cartridge and squeeze the handle.
- Tip piercer/cleaner for clearing sealant from dried nozzles.
- Hook end suitable for attaching to user's belt.

REGB83



Premier Stumpy Sealant Gun

- Specifically designed for REGZ31 & REGZ32 Silicate Cement (smaller for more control and access in confined spaces).
- Very strong construction (in order to deal with the high viscosity of our silicones and silicates).
- Includes tip cutter, just insert the nozzle of the cartridge and squeeze the handle.
- Tip piercer/cleaner for clearing sealant from dried nozzles.
- Hook end suitable for attaching to user's belt.
- Push rod quick release system.

REGB85



Economy Silicone Gun

- Suitable for use with 310ml cartridges.



**For all the latest products
from Regin visit our
BRAND NEW website:**

www.regin.co.uk

VDE 1000V Insulated Screwdrivers

- Suitable for live working up to 1000 volts AC.
- Chrome molybdenum shafts.
- Magnetic, corrosion resistant tips.
- Approved by TUV/GS to European standard EN 60900.
- Power Grip handles for ultimate comfort, power and control.
- Recessed fingerstops to prevent slipping.



Slotted 1000V Screwdriver

Types available:

- **REGE235** - 3.5mm x 100mm Slotted Screwdriver
- **REGE240** - 4.0mm x 100mm Slotted Screwdriver
- **REGE255** - 5.5mm x 125mm Slotted Screwdriver
- **REGE265** - 6.5mm x 150mm Slotted Screwdriver

Straight



Pozi 1000V Screwdriver

Types available:

- **REGE271** - No. 1 Pozi Screwdriver
- **REGE272** - No. 2 Pozi Screwdriver

Pozi



Phillips 1000V Screwdriver

Types available:

- **REGE273** - No. 1 Phillips Screwdriver
- **REGE274** - No. 2 Phillips Screwdriver

Phillips



Electrical Hand Tools

REGE285**12pc VDE 1000V Interchangeable Blade Screwdriver Set**

- Hardened and tempered Chrome Vanadium steel shafts.
- Magnetized tips with a phosphate finish for resistance to corrosion.
- Insulated and VDE/TUV/GS approved for use up to 1000V AC and 1500V DC.
- Impact resistant handle with a contoured, comfortable grip and switch release mechanism.
- Interchangeable blades lock securely within the handle.
- Includes mains tester.
- Supplied in carry case.

Contents:

Slotted: 3 x 100mm, 4 x 100mm,
5.5 x 100mm, 6.5 x 100mm,
Phillips: #1 x 80mm, #2 x 100mm,
Pozi; #1 x 80mm, #2 x 100mm,
TRX-Star: T10 x 100mm, T15 x 100mm,
T20 x 100mm.

Mains Tester &
Driver Handle

**REGE280****8pc VDE 1000V Screwdriver Set**

8 piece screwdriver set

- Set comprises four slotted, two Phillips & two Pozidrive screwdrivers.
- Chrome Vanadium shafts with magnetic and corrosion resistant precision tips.
- Insulated and VDE/TUV/GS approved for use up to 1000V AC and 1500V DC.
- Impact resistant handles with contoured, comfort grip for added torque transfer.

Contents:

Slotted: 3 x 75mm, 4 x 100mm,
5.5 x 125mm & 6.5 x 150mm
Phillips: #1 x 80mm & #2 x 100mm
Pozi: #1 x 80mm & #2 x 100mm



Insulated Terminal Drivers

- High quality special alloy chrome vanadium blade for longer life.
- Ultra comfort swivel top gives speed and control.
- Thin sleeve protected blade still gives excellent access.

Types available:

- **REGE251** - 3.5mm x 100mm Slotted Screwdriver
- **REGE252** - PZO x 100mm Pozi Screwdriver



Multi-Test Electrical Screwdriver

Quick, safe and simple to use

- Fully insulated - no finger contact to operate.
- Clearly identifies phase-neutral/earth.
- Simple microwave leakage test.
- Bright indication even in sunlight.
- Quality tough polycarbonate construction.



Detects microwave leakage



Tests AC voltage (contact testing & non-contact testing)



Tests bulbs and fuses



Locates 'break' point



Verify DC polarity

1000V Cable Shears

220mm

- Engineered to meet the requirements of the professional.
- Individually tested to 10,000V.
- Guaranteed cutting edge hardness suitable for hard and soft wire.
- Superb ergonomic handles.
- Cuts and strips.
- Not suitable for cutting steel wire armoured cables.



Electrical Hand Tools



1000V Combination Pliers

- For electrical work up to 1,000V AC or 1,500V DC.
- Fully conforms to Euronorm standards - IEC 900, EN 60900.
- Individually tested to 10,000V.
- Power grip composite handles for ultimate power and control.
- Finger stops to prevent slipping onto live conductors.
- High quality machined pivots for easy one handed operation.
- Helps user to comply with Electricity at Work Regulations.

Types available:

- **REGE211** - Large Combination Pliers 200mm
- **REGE210** - Small Combination Pliers 160mm



1000V Diagonal Cutting Pliers

- For electrical work up to 1,000V AC or 1,500V DC.
- Fully conforms to Euronorm standards - IEC 900, EN 60900.
- Individually tested to 10,000V.
- Power grip composite handles for ultimate power and control.
- Finger stops to prevent slipping onto live conductors.
- High quality machined pivots for easy one handed operation.
- Helps user to comply with Electricity at Work Regulations.

Types available:

- **REGE216** - Large Diagonal Cutters 200mm
- **REGE215** - Small Diagonal Cutters 160mm



1000V Long Nose Pliers

200mm

- For electrical work up to 1,000V AC or 1,500V DC.
- Fully conforms to Euronorm standards - IEC 900, EN 60900.
- Individually tested to 10,000V.
- Power grip composite handles for ultimate power and control.
- Finger stops to prevent slipping onto live conductors.
- High quality machined pivots for easy one handed operation.
- Helps user to comply with Electricity at Work Regulations.

REGE220**Automatic Wire Stripper**

200mm

- Strips flat cables (up to 2.5mm² twin and earth) and round cables up to 6mm diameter.
- Fully automatic, grips and strips in one action.
- Adjustable cable strip length guide swivels clear for longer strip.

REGE228**Ratchet Crimping Tool**

- For pre-insulated terminals: blue, red and yellow (see pgs 155-157).

REGB80

Electrical

REGXE40



Low Cost Multimeter with Temperature

- EN61010-1 CATIII 600V.
- Double moulded plastic housing.
- Auto Ranging and Data Hold.
- Type K temperature probe.



Dual Temperature



Auto Power Off

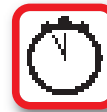

Quick Measurement



Accurate



Easy Operation



Large Display

REGXE45



3-in-1 Autoranging Multimeter

- Auto Ranging.
- Data Hold.
- Non-Contact Voltage Detection.
- Auto Power Off.
- Flashlight.
- 20 mA Fused protection.
- EN61010-1 CATIII 1000V.
- Diode Check.
- Continuity Test.
- Double Moulded housing.



Continuity Testing



Auto Power Off



Quick Measurement



Accurate



Easy Operation

Voltage/Continuity Indicator

- Continuity Test.
- Single Pole Phase Test.
- Self Test Button.
- Measurement point illumination.
- LED Voltage Range (AC/DC):
12, 24, 36, 50, 120, 230, 400, 690V.
- CAT III 1000V / CAT IV 600V.



Continuity Testing



Auto Power Off



Quick Measurement



Accurate



Easy Operation

REGXE15



AC Voltage Detector with Torch

- Non-contact detection of AC voltage from 100VAC to 600VAC.
- Glows red to indicate voltage.
- For use on 50/60Hz circuits.
- Built-in bright flashlight.
- CAT III 1000V.



Quick Measurement



Easy Operation

REGXE09



Electrical

REGT16**Volt Stick**

- The New Volt Stick non-contact voltage detector provides excellent voltage detection.
- New balanced sensitivity gives more accurate detection.
- The latest in electronic design enables bright RED LED indication.
- Low current circuits means long battery life.
- Clearly detects 90 - 600 V AC without metal contact.
- Tip glows red when voltage is detected.
- Pocket size for handy use anywhere.

REGT18**Duo Voltage Sensor**

- Quickly detects 90 - 600 volts AC without direct metal contact.
- Dual sensitivity helps pinpoint the live wire.
- Bi-colour LED indication of correct operation (green) and volts present (red).
- Audible indication of correct operation and warning of volts present.

REGT15**Volt Sensor**

- To help ensure an appliance to be worked on is not 'live' and for testing the presence of voltage on electrical lines, cables, sockets and switches without touching the object being tested.
- The Volt Sensor has both visual and audible warnings.
- Supplied complete with batteries (REGEAG13).

Magnet Tester

- Solenoid valve tester supplied complete with batteries (*REGAAAA4 x 2*).
- A lamp housed in the end of the unit lights up when a magnetic field is picked up by a sensor in the probe end.
- Supplied with a test ring magnet which also enables this useful tool to be used as a torch when placed on probe end.

REGT10



MagTester Plus

Good for checking almost any electro magnetic field i.e:

- Gas valve solenoids.
- Oil pump solenoids.
- Pump Motors.
- Diverter valve motors.
- Relays: Mains or Low Voltage.
- Most if not all electric motors.
- Car starter solenoids.
- Test magnet housed opposite tip end.

REGT08



RCD Plug In Circuit Breaker

- To help ensure safer working practices.
- Added protection against the risk of electrocution.
- Suitable for use with all makes of electrical and gardening appliances.
- No need to remove from socket to reset unit.

REG50



Electrical

REGE20**Digital Multimeter**

- 27 ranges for AC/DC voltage and current.
- Standard multimeter and temperature probes included.
- Diode test.
- Continuity and resistance test.

REGE40**Fused Multimeter Probes**

- To comply with H&SE guidance note GS38.
- Compliant with European Standard IEC 1010.

REGE45**Multimeter Crocodile Clips**

- For use with *REGE40*

REGE30**Safety Test Plug**

- A 13 amp checking device which is plugged into a 13A live socket to check the correct wiring of power sockets before use.

AAV Removal Tool

The Regin AAV Removal Tool is designed to assist in the replacement of the Caleffi Robocal 502 series Automatic Air Vents, particularly where access with a normal spanner or grips is at best very difficult due to location within the appliance.

- For easy replacement of:
Caleffi Robocal 502 Series
AAVs found on many Combi
Boilers & Pumps.
- Includes 7mm Bolt for
awkward locations.
- Available in two sizes:
- **REGT30** - Standard
AAV Removal
Tool
- **REGT31** - Extended
AAV Removal
Tool

**REGT30****REGT31**

Thermocouple Tester

- Used for testing the correct operation of thermocouples.
- The thermocouple to be tested is assembled into the unit and the tip heated whilst depressing the white button. If the thermocouple is functioning correctly the plunger will remain depressed for approx. 20/30 seconds, simulating the operation of a gas valve.

REGT20

Specialist Tools

REGT25**Multi-Size Fan Puller**

- Suitable for most Riello and four splined pump drive fan impellers.

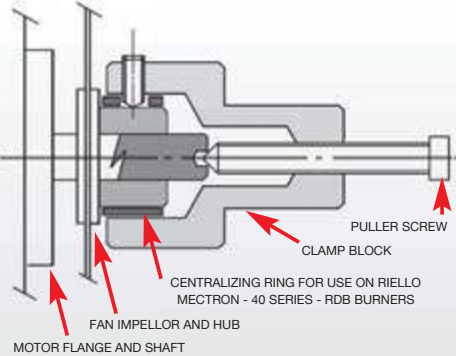
**REGT11****Illuminated 'Bits'n'Bolts' Retriever**

- Heavy-duty five section telescopic pick-up tool.
- Large Ø14mm magnet with 3.6kg capacity and recessed LED to illuminate target area.
- Textured, contoured handle for added comfort.
- Knurled twist on/off switch for ease of use.
- Extends to approx: 81cm (32") in length.
- Complete with pocket clip.

REGT35**Inspection Mirror - Small**

- 30mm diameter mirror.
- All-angle ball joint.
- Extends to approx. 60cm (24") in length.
- Complete with pocket clip.

REGT40**Inspection Mirror - Large**

- 50mm diameter mirror.
- All-angle ball joint.
- Extends to approx. 45cm (18") in length.

Regin Eye Video Borescope

The Regin Eye Video Borescope inspection system features a 2.4" LCD colour monitor for real-time viewing.

- Features a 100cm (approx.) water resistant (IP67) flexible gooseneck with a 10mm diameter camera head for inspecting hard-to-reach areas.
- Integrated adjustable bright white LEDs for illuminating darkened spaces.
- Clip-on magnet and hook tips Included. The strong magnetic tip allows you to pick-up nuts, bolts and screws from inaccessible places. The hook tip J-shaped extension can be used to tug, pull or pick up small objects or wires.
- NTSC TV video output (cable included).
- Supplied in protective carry case.

REGX90



NEW



**For all the latest products from Regin
visit our BRAND NEW website:**

www.regin.co.uk

Specialist Tools

REGK75**Free-AirGauge Kit**

Regin Free-AirGauge Kit has been developed to assist registered installers to quickly, easily and accurately determine the free area of existing ventilation.

- The kit consists of the following three main components:
A 3-piece precision aluminium tool, colour coded for convenience.
A vernier gauge to accurately measure the ventilator(s) installed.
A slide calculator to determine the free area of the ventilation provided.
- The Free-AirGauge was developed with the review of the unsafe situations in mind: It is now vital that the free area of existing ventilation is accurately determined, as this may affect the category of unsafe situation applicable.
- The Free-AirGauge will assist the registered installer to make the right decision and improve the standards of gas safety.
- Complete kit supplied with keyring and carry case.

**REGC10****10mm Continuity Bond**

Length 1.2m

- For ensuring temporary continuity of earth.

REGT19**Thermocouple Thread Gauge**

- For determining the exact size of thermocouple threads.
- Capable of sizing six threads: M8, M9, M10, 1/8" BSP, 7/16" and 11/32".

Rechargeable 360° Inspection Lamp

REGE360

Regin Cordless 360° Lithium-ion Inspection Lamp

Perfect for precise directional illumination in confined areas or equally as useful where widescale illumination of large spaces is required.

- Incorporates a patented ball joint design which allows you to rotate the Lamp through a full 360 degrees.
- The powerful 10 SMD LED main light floods your work area with light.
- Includes a 3 watt high power LED in the end allowing use as a torch.
- The lamp can be attached in two ways:
 - Using the 3 magnets (2 in the rear of the unit & 1 in the base), for use on any ferrous metal.
 - Hung using the two built in hooks.
- The rechargeable Lithium-ion battery suffers no memory effect meaning that it can be charged at any time.
- The main light can be dimmed to prolong battery life.
- The lamp is housed in a tough rubberised anti slip casing in a striking bright green colour.
- Patent pending



**LITHIUM-ION
2.2Ah**



Lamps & Torches

REGE11**27 LED Home Work Light**

- 27 LED bulbs.
- Powered by 3 x AAA batteries (not included).
- Inbuilt magnet on reverse.
- Inbuilt hanger.
- Non-slip surface.
- Product size: 9.7 x 6.3 x 3.5cm.

**24 + 3 x LED****20h
Battery Life****20m
Range****Inbuilt
Hanger****Inbuilt
Magnet****REGE12****24 LED Engineers Work Light**

- 24 LED bulbs.
- Powered by 3 x AAA batteries (not included).
- Inbuilt magnet on reverse.
- Inbuilt hanger.
- Non-slip surface.
- Product size: 21 x 6 x 3cm.

**24 + 3 x LED****20h
Battery Life****20m
Range****Inbuilt
Hanger****Inbuilt
Magnet****REGE13****LED Pen Light**

- Magnetic attachment on swivel clip.
- 7 long life LED's.
- Powered by 3 x AAA batteries.
- Swivel pocket clip.
- 250 Lux Light intensity.
- 50 lm Light output.
- IPX3 Splash resistant.
- >11h Battery runtime.
- 1m Drop test.

**50 LUMENS****11h****7 LED's****Inbuilt Magnet****Splash
Resistant**

Lamps & Torches

Premier LED Torch

- Powered by 29 super-bright LED lights.
- Water resistant & shockproof.
- Uses 3 x AAA batteries (included).
- Over 20 hours continuous use.
- 80,000 hours of LED life.
- Very low cost per hour of operation.

REGE10



Premier LED Headlight

- Powered by 19 super-bright LED lights.
- 4 functions: 1 LED, 7 LED's, 19 LED's & 19 LED's flashing.
- Hands-free convenience.
- Lamp tilts through 90 degrees.
- Long LED bulb life.
- Solid state circuitry for longer battery life.
- Uses 3 x AAA batteries (not included).

REGE15



NEW



For all the latest products from Regin
visit our BRAND NEW website:

www.regin.co.uk

Thermometers



K-Type Thermometer and Probe Kit

- Adjustable probe angle through 180 degrees.
- 4 probes for a variety of applications: Air, Surface, Penetration and Immersion.
- Measurement range: -100°C to +300°C.
- Switchable °F/°C.
- Hold function.
- Max/Min function.
- Supplied in a tough carry case.



Dual Temperature



Quick Measurement



Easy Operation



Accurate



Large Display



Stainless Sensor Probe



Multi- Thermometer with Probe

- Fast response.
- 133mm stainless steel probe extendable to 1 metre.
- Measurement range: -50°C to +150°C.
- Switchable °F/°C.
- Auto Power Off.
- Hold Function.
- Max/Min Function.



Dual Temperature



Auto Power Off



Quick Measurement



Accurate



Easy Operation



Large Display



Stainless Sensor Probe



3-in-1 Thermometer

- Infra Red Temperature Measurement: -35°C to +260°C (Optical Resolution: 1:1 Distance to Spot Size).
- Thermistor Probe Temperature Measurement: -40°C to +260°C.
- Clamp Temperature Measurement: -40°C to +200°C (clamp opening ≈ 25mm).
- Switchable °F/°C.
- Auto Power Off.
- Hold Function.
- Max/Min Function.



Dual Temperature



Auto Power Off



Quick Measurement



Accurate



Easy Operation



Stainless Sensor Probe

Pocket Infra Red Thermometer

- Non-contact temperature measurement.
- Laser targeting.
- Backlit LCD Display.
- Measurement Range: -30°C to $+260^{\circ}\text{C}$.
- Optical Resolution: 8:1 Distance to spot size.
- Switchable $^{\circ}\text{F}/^{\circ}\text{C}$.
- Auto Power Off.
- Hold Function.
- Max/Min Function.



Dual Temperature



Auto Power Off



Quick Measurement



Accurate



Easy Operation

REGXE65



Pipe Contact Thermometer

Easy to use surface pipe thermometer.

- Measuring range: $0 - 120^{\circ}\text{C}$
- Features a 80mm easy to read dial.
- The dial face has a clear, graduated scale indicating temperature in 2°C divisions.
- Supplied with a wrap-around spring kit for mounting to pipes between 1" and 2". For larger pipes it is possible to attach the thermometer using either tie-wraps or wire (not supplied).

REGV15



Stove Pipe Thermometer

- Monitor the performance of your wood or multi fuel stove.
- Easy to read.
- Attaches magnetically.
- $^{\circ}\text{C}$ and $^{\circ}\text{F}$ scales.
- Improves stove's efficiency.

REGST75



Thermometers

REGV20



Differential Thermometer

- Measurement range: -50°C to $+1300^{\circ}\text{C}$
- Max reading memory feature.
- Low battery indicator.
- Calculates temperature difference.
- Can be used as a single input thermometer.
- Dual input.
- Please note that probes are not included.

REGV25



Water/Air Immersion Probe

- Probe dimension: 4.5mm diameter x 130mm long.
- Operating temperature range: -50°C to $+250^{\circ}\text{C}$.
- This rigid, stainless steel probe is strong and versatile.
- Response time is less than 3 seconds.

REGV30



Surface Probe

- Probe dimension: 6mm diameter x 130mm long.
- Operating temperature range: -50°C to $+600^{\circ}\text{C}$.
- Probe has a spring loaded copper disc sensing tip.
- Response time is less than 2 seconds.

REGV35



Wraparound Probes

- 1 Pair
- Max. temperature 100°C .
 - Suitable for pipes up to 80mm diameter.
 - Velcro fastening.

REGV40



Flexible Wire Probe

- Length: 1 metre .
- Max. temperature 400°C .
- Suitable for use in ovens.

REGV45



Crocodile Type Clamp Probes

- 1 Pair
- Gives excellent close fit to pipes for fast and accurate readings.
 - Suitable for pipes from 6mm to 30mm in diameter.
 - Operating temperature range: -50°C to $+100^{\circ}\text{C}$.
 - Response time is less than 2 seconds.

Digitemp Thermometer Kit

- Kit comprises:
 - 1 x REGV20 Differential Thermometer.
 - 1 x REGV25 Water/Air Immersion Probe.
 - 1 x REGV30 Surface Probe.
 - 1 pair x REGV45 Crocodile Type Clamp Probes.

See page 58 for full details and specifications.

- Supplied in a hard wearing carry case.



Water & Pipe Temperature Kit

- Kit comprises:
 - 1 x REGV20 Differential Thermometer.
 - 1 x REGV25 Water/Air Immersion Probe.
 - 1 pair x REGV45 Crocodile Type Clamp Probes.

See page 58 for full details and specifications.



Waterproof Stem Thermometer

- Replacement thermometer for REGM31.
- 133mm Stainless steel probe.
- Measurement range: -50°C to +150°C.
- Switchable °F/°C.
- Auto Power Off.
- Hold function.
- Max/Min function.



Waterproof



Dual Temperature



Auto Power Off



Quick Measurement



Accurate



Easy Operation



Stainless Sensor Probe

Brushes & Abrasives

REGT81**9mm Nylon Tube Brush**

9mm diameter

- For cleaning the Venturi on wall hung boilers.

**REGT82****Ventilator Triangular Cleaning Brush**

240mm long

- For cleaning the ventilator of wall hung boilers.

**REGT83****10mm Burner Hole Cleaning Brush**

10mm diameter

- For cleaning the burner holes on wall hung boilers.

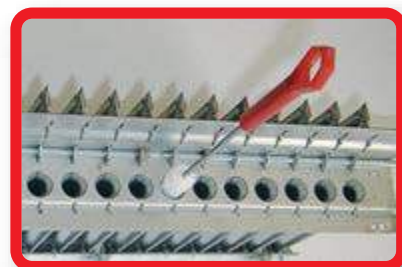
**REGT84****Heat Exchanger Cleaning Brush**

100mm x 170mm

- For cleaning the heat exchanger of wall hung boilers.



Boiler Flue Gas Path Cleaning Brush



30mm x 420mm

- For cleaning the flue gas paths of floor standing boilers.

REGT86



Large Boiler Flue Gas Path Cleaning Brush



40mm x 500mm

- For cleaning the flue gas paths of floor standing boilers.

REGT87



70mm Nylon Tube Brush



70mm x 320mm

- Nylon tube-brush for efficiently cleaning condensing boilers.

REGT88



Multi-Purpose Boiler Cleaning Brush



60mm x 440mm

- General purpose 60mm diameter polypropylene tube-brush for internal boiler cleaning.

REGT89



Brushes & Abrasives



REGT79

Long Radiator Brush

- A long round nylon brush ideal for cleaning behind radiators or in any inaccessible areas.
- Approx. length: 710mm.
- Diameter of brush: Approx. 40mm.



REGT55

Flue Brush Set

Set of 3 brushes

- Set comprises:
16mm (5/8") round x 500mm,
50mm (2") flat x 500mm &
50mm (2") round x 500mm
brushes.



REGT56

Oil Boiler Flue Brush Set

Set of 3 brushes

- Set comprises:
25mm (1") round x 500mm,
50mm (2") round x 500mm &
75mm (3") round x 900mm
brushes.



REGT51

7 piece Flue Brush Set

Set comprises:

- 12" handle.
- 5" handle.
- 12" extension rod.
- 12" thin flexible extension rod.
- 50mm round long brush head.
- 50mm round short brush head.
- 50mm flat brush head.

Brushes & Abrasives

Brass Wire Brush

270mm long

- Multi purpose brass wire brush.
- Positive grip handle.

REGT80**Soft Bristle PVC Brush**

270mm long

- Multi purpose soft bristle brush.
- Positive grip handle.

REGT85**Long Cleaning Blade**

400mm long

- For cleaning heat exchangers.
- Designed not to damage the heat exchanger.

REGT75**Short Cleaning Blade**

200mm long

- For cleaning heat exchangers.
- Designed not to damage the heat exchanger.

REGT76**Extra Thin Cleaning Blade**

400mm long

- For cleaning heat exchangers.
- Designed not to damage the heat exchanger.
- Double ended.

REGT77

Brushes & Abrasives

REGM80**Steel Wool****Medium Grade**

- For general purpose work, cleaning of copper pipe and fittings, paint removal and preparation.
- 450g.

REGM40**Silicone Carbide Abrasive Strips**

- 10 Mini-strips.
- For cleaning sanding & roughing plastic, metal, wood & other surfaces.
- Use both sides.
- More aggressive.
- Longer Lasting.
- Waterproof.
- Doesn't load up.
- Silicone Carbide 180 grit.

REGM41**Silicone Carbide Abrasive Strip**

- 5 metre roll.
- Medium grade.
- Silicone Carbide 180 grit.

REGM42**Abrasive Mini Pads**

- General purpose grade.
- 5 pads per pack.
- Suitable for cleaning, polishing, rust removal, scrubbing and blending.



Premier Part P Kit

Insulation/Continuity, Loop Impedance/PFC & RCD tests
all in one easy to use package

- Three great testers in one compact kit.
- Individual instruments - The same kit can be shared so that different tests can be carried out at different sites.
- 17th Edition testers.
- Kit comprises:
 - *REGXP1* Part P Digital Insulation and Continuity Tester
 - *REGXP2* Part P MultiFunction Digital Loop Tester
 - *REGXP3* Part P MultiFunction Digital RCD Tester
 - *REGXP8* Socket Interface Adaptor
 - *REGXP9* One-Click Test Lead Set
 - *REGXP7* Red/Black Insulation Test Lead Set
 - *REGXP101* Instrument Case
 - *Instruction manuals and batteries*

Part P Test Equipment



REGXP1



Part P Digital Insulation & Continuity Tester

Full Part P verification

- 2 way-250, and 500 Volt insulation plus full 200mA continuity test.
- Continuity measurement up to 10KΩ.
- Uses only 4 x AA alkaline batteries giving over 5000 tests at 500V.
- Fully protected against accidental live voltage contact up to 600V AC.
 - Null function to eliminate lead resistance up to 2Ω.
 - Intelligent auto shut-off to preserve battery life.
 - Supplied complete with quality test leads, carry case and manual.
 - 17th Edition tester.



REGXP2



Part P MultiFunction Digital Loop Tester

Includes Prospective Fault Current Test

- 4 in 1 digital tester - loop (including PFC), mains voltage, correct wiring, correct polarity.
- Patented no-trip loop test technology.
- Fully protected against accidental phase to phase connection.
- Instant readout of PFC (Prospective Fault Current).
 - Built-in correct wiring indication.
 - Accurate mains voltage measurement to latest BS7697.
 - Unique Polarity test gives ultimate overall system safety check.
 - Carry case, test leads and manual included.
 - 17th Edition tester.



Part P MultiFunction Digital RCD Tester

RCD Testing made simple

- Easy to use with auto sequence (not auto test) or manual override.
- Auto sequence test in line with latest NICEIC recommendations - x 1, x 5, x 1/2.
- Tests all common types of 30mA and 100mA RCDs.
- Built-in correct wiring indication.
- Accurate mains voltage measurement to latest BS7697, HD 472 S1.
- Unique Polarity test gives ultimate overall system safety check.
- Carry case, test leads and manual included.
- 17th Edition tester.



REGXP3



Component Exchange Loop Tester

Enhanced protection for you and your customers

- 4 in 1 LED tester - loop, mains voltage, correct wiring, correct polarity.
- Patented no-trip loop test technology.
- Fully protected against accidental phase to phase connection.
- Accurate mains voltage measurement to latest BS 7697, HD 472 S1.
- Built in proven REGE30 correct wiring indication.
- Unique Polarity test gives ultimate overall system safety check.
- Carrying case, test leads and manual included.



REGXP5



Part P Test Equipment

REGXP8

Socket Interface Adaptor

- Enables you to leave sockets in place.
- An essential piece of equipment in every Part P engineer's tool kit.
- Plug the leads from your digital insulation/continuity tester directly into the adaptor.
- Extremely cost effective.
- Time saving.
- No more damage to decorations.
- No broken connections.
- 17th Edition accessory.

REGXP9

One-Click Test Lead Set

Fused test leads

- High protection fused lead set compatible with all loop and RCD testers using a standard IEC mains input socket.
- Uses the new harmonised mains colours of brown and blue - the strain relief is in red and black to give a reminder of the changes.
- 10A HRC ceramic fuses fitted in each probe.
- Fuse stays in place - just switch between probe and croc clip with new one click system.
- Stackable earth croc clip means neutral can combine with the earth, meaning just one croc clip to connect.
- 17th Edition accessory.

REGXP7

Red/Black Insulation Test Lead Set

106cm non-fused test leads

- 4mm to 4mm.
- Kit includes:
 - 1 pair of leads
 - 1 pair of probes
 - 1 pair of croc clips
- 17th Edition accessory.
- For use with *REGXP1* and *REGXP8*.

PAT Adaptor

- Conducts Pat testing using your Insulation/Continuity tester (*REGXP1*).
- Test your own tools and workplace.
- Fast earth bond tests.
- Class I and Class II insulation tests.
- Works with universal 4mm test leads.
- Pass PAT stickers available separately (see below).

REGXP25

PAT Adaptor & Insulation/Continuity Tester Kit

- Kit includes:
 - REGXP25 - PAT Adaptor (See above for details).
 - REGXP1 - Digital Insulation & Continuity Tester (See page 66 for details).
 - REGXP7 - 4mm Test Lead Set. (See page 68 for details).
 - Supplied in a padded carry case.

REGXP125

PAT Testing Pass/Fail Stickers

- **REGXP26** - Pass Stickers (50 per pack).
- **REGXP27** - Fail Stickers (20 per pack).



Miscellaneous

**REGM75****Bungee Straps**

- A pair of high quality Luggage Straps.
- Ideal for securing luggage and goods.
- High tensile, vinyl coated steel hooks.
- TUV GS approved.

- Available in two sizes:

- **REGM75** - 450mm Bungee Strap (x2)

- **REGM76** - 600mm Bungee Strap (x2)

**REGM76****REGM60****Mag Dish**

- Magnetic parts dish.
- Powerful base magnet will adhere to boiler casings in vertical or horizontal positions.
- Keeps metallic Bits 'n' Bolts etc in one place whilst working on an appliance.
- Approx. diameter: 150mm.

**REGS40****Pocket Rocket**

- Produces a powerful blue flame.
- Ideal for igniting smoke pellets.
- Refillable (with Butane lighter gas).

**REGH05****Contour Turner**

- Used to give leverage for turning small difficult items eg. gas or radiator taps.
- Stainless steel rods, when pressed around an object, retract, conform around its shape and provide a purchase around it when the handle is turned.
- An excellent everyday household aid, especially useful for the elderly or infirm.

Smoke Smoke Pellets, Smoke Matches etc	72
Tapes ID Tapes, Foil Tape, Boiler Case Seal, Foam Tapes, PTFE Tapes etc	76
First Aid & Fire First Aid Kits, Fire Extinguishers etc	82
Report Pads Inspection Pads, Service Pads, Advice Notice Pads, Commercial Pads, etc	83
Stickers & Tags Warning Stickers & Tags, Advice Stickers, Service Stickers etc	90
Electrical Stickers & Tags Warning Stickers & Tags etc	94
Marker Pens Paint Marker Pens	96
Location Plates Plastic Location Plates	97
Solder Mats Heat Dissipating Flame Retardant Spray, Solder Mats	98
Kits Appliance Servicing Kits, Fuse Kits, Olive & Washer Kits etc	99
O-Ring Kits Imperial & Metric Nitrile O-Ring Kits	102
Service Aerosols & Paints Air Dusters, Cleaning Spray, Silicone Spray, Adhesive, Coal Paint etc	104
Leak Detection Leak Detector Aerosol, Leak Detector Sprays	106
Sealants etc Silicone Sealants, Silicone Grease, Heat Sink Compound etc	107
Inspection Hatches Inspection Hatches, Fire Rated Hatches	112
Glass Yarn & Fixative Glass Yarn, Glass Yarn Adhesive	113
Gloves Work Gloves, Latex Gloves, Vinyl Gloves, Nitrile Gloves, Heat Resistant Gloves etc	114
Dustsheets Dustsheets, Service Mats, Work Mats etc	117
Wipes & Work Wear Paper Towel, Hand Wipes, Dust Masks, Safety Goggles etc	120
Batteries Alkaline Batteries	122
Spares Safety Connectors, Radiator Tops, Ignition Leads, Relays etc	124

Smoke

REGS15**FUMAX Smoke Pellets - 10****Pack of 10 pellets**

- BS5440 Part 1 compliant.
- Approx. 30 second burn time.
- Produces an estimated 5 cubic metres of smoke with an ideal density for flue testing.
- Encapsulated for ease of use and disposal.

**REGS20****FUMAX Smoke Pellets - 100****Tub of 100 pellets**

- BS5440 Part 1 compliant.
- Approx. 30 second burn time.
- Produces an estimated 5 cubic metres of smoke with an ideal density for flue testing.
- Encapsulated for ease of use and disposal.
- Supplied in a tough resealable water resistant container.



FUMAX Kingsize Smoke Pellets - 10



Pack of 10 King Size pellets

- BS5440 Part 1 compliant.
- Approx. 60 second burn time.
- Produces an estimated 15 cubic metres of smoke with an ideal density for flue testing.
- Encapsulated for ease of use and disposal.



FUMAX Kingsize Smoke Pellets - 50

Box of 50 King Size pellets

- BS5440 Part 1 compliant.
- Approx. 60 second burn time.
- Produces an estimated 15 cubic metres of smoke with an ideal density for flue testing.
- Encapsulated for ease of use and disposal.
- Supplied in tough resealable water resistant containers.



Smoke

REGS21**FUMAX Red Smoke Pellets****Pack of 10 pellets**

- Produces approx. 30 seconds of dense red smoke for better visibility against white/grey skies.
- Encapsulated for ease of use and disposal.
- Please note that this product is likely to stain.

**REGS50****Steady-Stream Smoke Wands****Pack of 10 Smoke Wands**

- Provides a steady plume of smoke, particularly suitable for checking the integrity of positive pressure appliance case seals.
- This product does not contain any hazardous or corrosive substances.

**REGS10****Smoke Match Plume Kit**

- 30cm smoke match plume.
- 2 boxes of smoke matches (*REGS05*).
- Matches are supplied in a moisture resistant container.

Smoke Matches - 12



Box of 12 matches

- Approx. 15 second burn time.
- Produces a white smoke with an ideal density for spillage testing.

REGS05



Smoke Matches - 75



Tub of 75 matches

- Approx. 15 second burn time.
- Supplied in a resealable water resistant tub.
- Produces a white smoke with an ideal density for spillage testing.
- Average contents: 75 matches.

REGS06



Smoke Matches - 25



Tub of 25 matches

- Approx. 15 second burn time.
- Supplied in a resealable water resistant tub.
- Produces a white smoke with an ideal density for spillage testing.
- Average contents: 25 matches.

REGS07



Tapes

REGA05**'GAS' Tape**

33 metre roll

- 50mm wide.

REGA06**'GAS' Tape - Extra Long Roll - 66m**

66 metre roll

- 50mm wide.

REGA07**'OIL' Tape**

33 metre roll

- 50mm wide.

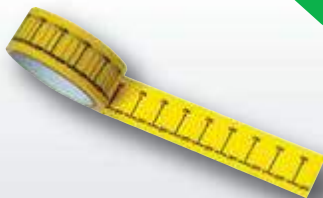
REGA10**'ON/OFF' Tape**

33 metre roll

- 38mm wide.

REGA15**'DANGER DO NOT USE' Tape**

33 metre roll

- 25mm wide.

'HEATING' Tape

- 33 metre roll
- 38mm wide.

**REGA20****'HOT WATER' Tape**

- 33 metre roll
- 38mm wide.

**REGA25****'DOMESTIC HOT WATER' Tape**

- 33 metre roll
- 38mm wide.

**REGA30****'COLD WATER' Tape**

- 33 metre roll
- 38mm wide.

**REGA35****'HOT WATER FLOW' Tape**

- 33 metre roll
- 38mm wide.

**REGA37****'HOT WATER RETURN' Tape**

- 33 metre roll
- 38mm wide.

**REGA38**

Tapes



REGA40

'DOMESTIC COLD WATER' Tape

33 metre roll

- 38mm wide.



REGA45

Black Arrow on Yellow Tape

33 metre roll

- 38mm wide.



REGA46

White Arrow on Blue Tape

33 metre roll

- 38mm wide.



REGA50

White Arrow on Green Tape

33 metre roll

- 38mm wide.



REGA55

'LPG' Tape

33 metre roll

- 38mm wide.



REGA60

'DRINKING WATER' Tape

33 metre roll

- 38mm wide.

Double Sided Foam Sealing Tape

Pack of 3 rolls

- Each roll is 3 metres long, 12mm wide, 1.5mm thick.
- Temperature range: (-40°C to +70°C).



Single Sided Foam Sealing Tape

Pack of 2 rolls

- Each roll is 4 metres long, 12mm wide, 12mm thick.
- Temperature range: (-40°C to +120°C).



Boiler Case Seal

5 metre roll (1 roll per pack)

- Expanded EPDM/Neoprene Sponge sealing strips.
- Adhesive backed.

Sizes available:



- **REGJ56:** 10mm thick x 10mm wide x 5m



- **REGJ57:** 5mm thick x 10mm wide x 5m

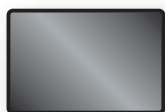

- **REGJ58:** 10mm thick x 15mm wide x 5m

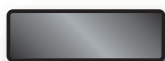

- **REGJ59:** 5mm thick x 15mm wide x 5m

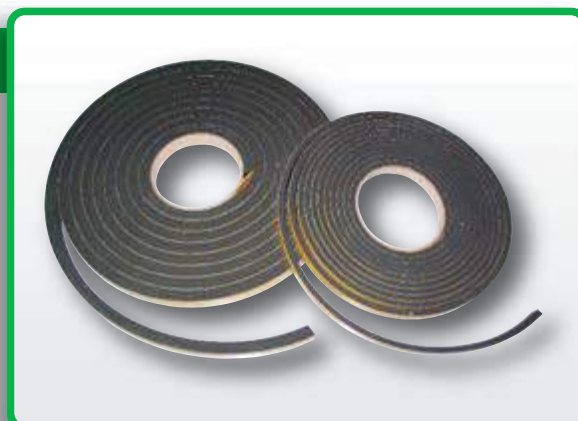

ASTM Designation	D-1056-68 D-1056-78 D-1056-85 Suffix Letters	SCE-42 RE-42 2A2 CE E MP
MIL-R-6130C		11-A
Type Grade		Soft
Condition		Medium
PHYSICAL PROPERTIES		
Colour		Black (Grey)
Compression Deflection		5-9
25% (PSI) (KN/m ²)		(35-63)
Ultimate Tensile Strength		100
(Typical Properties PSI KN/m ²)		(700)
Elongation (Typical Properties) %		175
Density (lb/cu ft)		7 + 2
(g/cc)		120 Kg/M ³
Fluid Immersion 7 Days at 73°F		
Ref. FuelB. Weight Change max %		250
Accelerated Ageing - 7 Days at 158°F		
Flexibility 180° Bend Without Cracking		Pass
Appearance Change		None
Change in compression Deflection		+ 30%
Water Absorption Max. Weight %		5
K. Factor		.30
Flame Resistance UL94HF.1		Pass
Service Temperature	Low High	-40°F 250°F/121°C
Intermittent		

Tapes

REGJ75



Duct Tape - Black

50 metre roll

- General purpose adhesive cloth duct tape.
- 48mm wide.
- Polythene coated cloth tape.
- Aggressive high tack adhesive.
- Temperature range 0°C to 70°C.
- For general purpose jointing, sealing, repairing, weatherproofing, packing and many other uses.

PVC Insulation Tape

Suitable for electrical insulation, binding, colour coding and general work.

- Conforms to BS3924.
- 19mm wide
- 20m long.
- Flame retardant.

Colours available:

- **REGQ641:** Black
- **REGQ642:** Red
- **REGQ643:** Green/Yellow Stripe
- **REGQ644:** Green
- **REGQ645:** Yellow
- **REGQ646:** Blue
- **REGQ647:** White
- **REGQ648:** Brown

REGJ64



Standard PTFE Tape

12 metre roll

- Complies to BS7786: 1995 Grade L.
- WRAS approved.

Multi-Purpose Silicone Temporary Repair Tape

WRAS Approved

- Multi-Purpose Clear Silicone Temporary Repair Tape.
- WRAS Approved.
- 3.6m roll.
- Self-fusing 'wrap & repair' silicone based tape.
- Simply stretch & wrap to repair water/plumbing leaks, insulate cables, seal & secure connectors, bind rope ends to prevent fray, exhaust & automotive repair and much more.

REGJ01



Aluminium Foil Tape

- 45 metre roll.
- Class "O" fire rated.
- BS476 Part 6 & 7.
- High temperature resistance.
- Water resistant.

Sizes available:

- **REGJ70:** 48mm wide
- **REGJ71:** 72mm wide
- **REGJ72:** 96mm wide

REGJ70



REGJ71



REGJ72

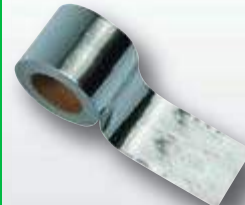

Gas Spec. PTFE Tape (One Wrap)

5 metre roll

- Complies to BS.EN. 751-3 1997.
- Can be used on threaded assemblies carrying Natural Gas, LPG, liquids etc.

REGJ65



First Aid & Fire

REGM46**First Aid Kit**

HSE 1-5 person

- Complies to current Health & Safety Executive Standards.
- Ideal for vans and cars.
- Measures approx. 22.5cm (w) x 16.5cm (d) x 4.8cm (h).

REGM47**Large First Aid Kit**

HSE 1-10 person

- Complies to current Health & Safety Executive Standards.
- Measures approx. 25cm (w) x 19cm (d) x 8.8cm (h).

REGM44**Fire Extinguisher - Powder 1kg with gauge**

- 1kg.
- ABC Powder extinguisher.
- Integral gauge.
- Non-toxic dry powder.
- 5 year guarantee.
- Mounting bracket included.

REGM45**Fire Extinguisher - Powder 600g**

600g

- Non-toxic dry powder (Sodium Bicarbonate).
- 5 year guarantee.
- Mounting bracket included.

REGM48**Fire Blanket**

- Conforms to BS EN1869
- Easy to use.
- Blanket size: 110cm x 110cm.

Landlord/Home Owner Gas Safety Record Pad

25 reports in triplicate

- Record safety checks carried out during a Landlord/Home Owner gas safety inspection.

REGP45

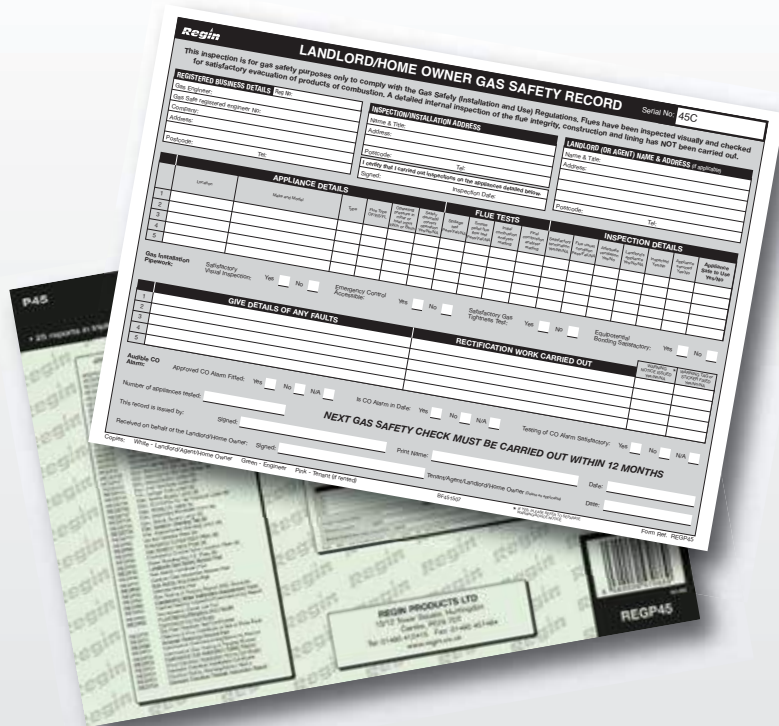

Gas Safety Certificate Pad

25 reports in triplicate

- Record details of gas work undertaken.
- Can be used as: Gas Safety Inspection Pad (REGP50) and/or Landlords Gas Safety Record Pad (REGP45).

REGP46

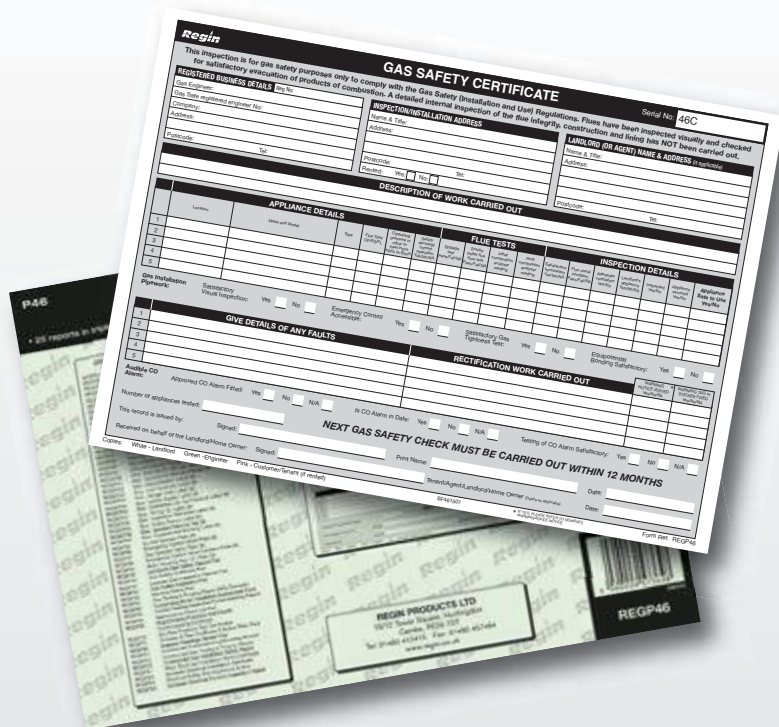

Report Pads

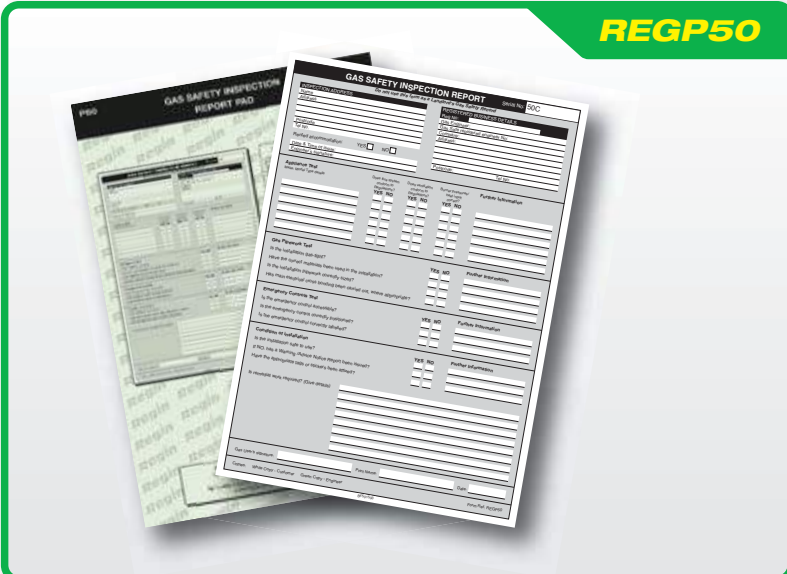

REGP50

Gas Safety Inspection Pad

50 reports in duplicate

- Record findings when carrying out general gas safety checks on a number of appliances.



REGP55

Warning/Advice Notice Pad

50 reports in duplicate

- Record Immediately Dangerous (ID), At Risk (AR) and Not To Current Standards (NCS) situations.



REGP65

Maintenance/Service Check List Pad

50 reports in duplicate

- For use when carrying out service or general maintenance work.

Caravan/Boat Gas Inspection Record Pad

REGP47

25 reports in triplicate

- Adhesive backed top copy.
- Specifically designed for gas safety checks on caravans and boats, which are rented out to the public.

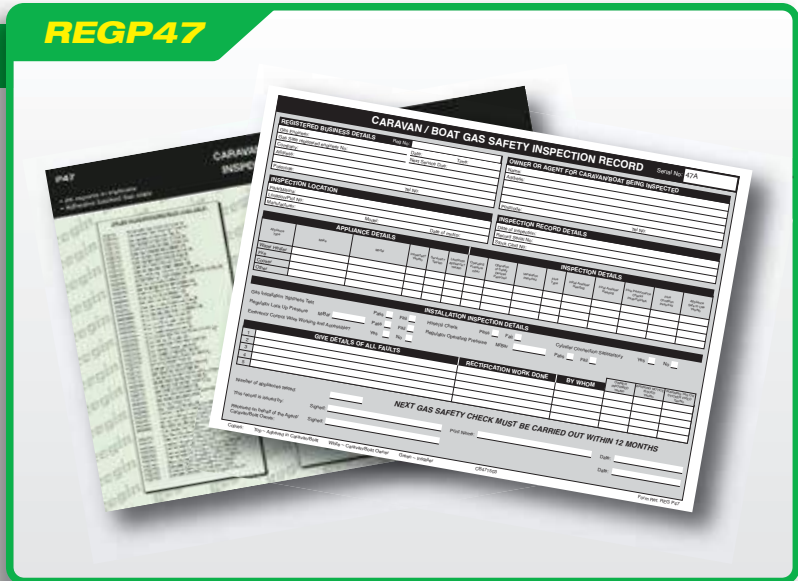

Mobile Catering Trailer/Vehicle Safety Record Pad

REGP56

25 reports in triplicate

- Record important gas safety checks carried out on mobile catering trailer/vehicles.
- Include details of the appliances, any safety checks carried out and the trailer/vehicle itself.

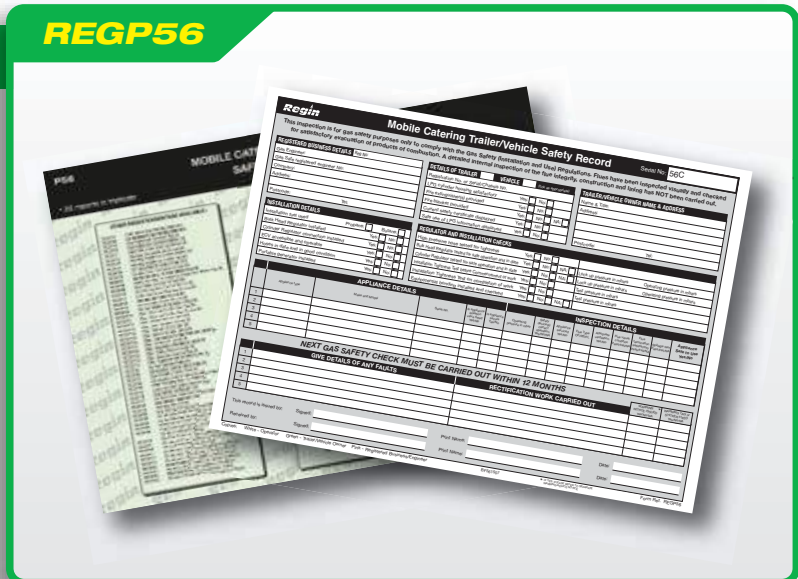

Unvented Hot Water Storage Vessel Commissioning Pad

REGP58

25 reports in triplicate

- For use in installing, inspecting or commissioning domestic unvented hot water storage vessels.

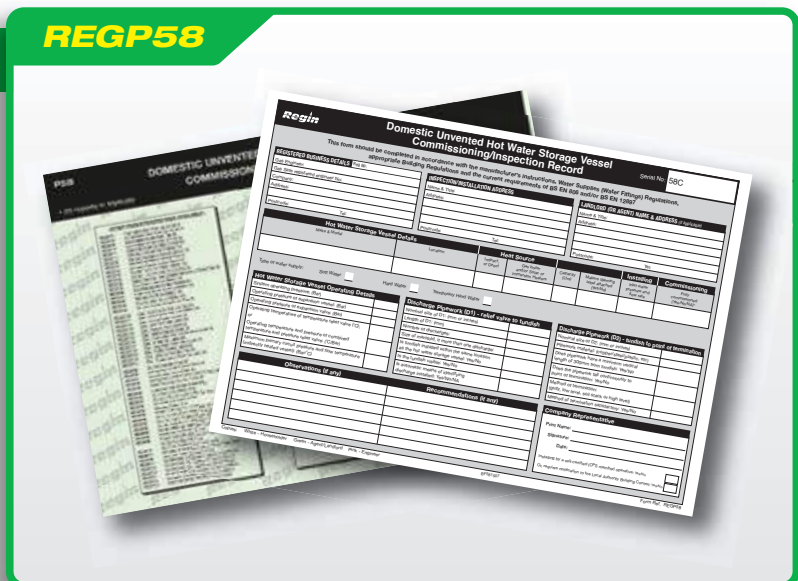

Report Pads



Gas Testing and Purging Report - Domestic

25 reports in triplicate

- Allows concise recording of each tightness test and details of purging that may be required.

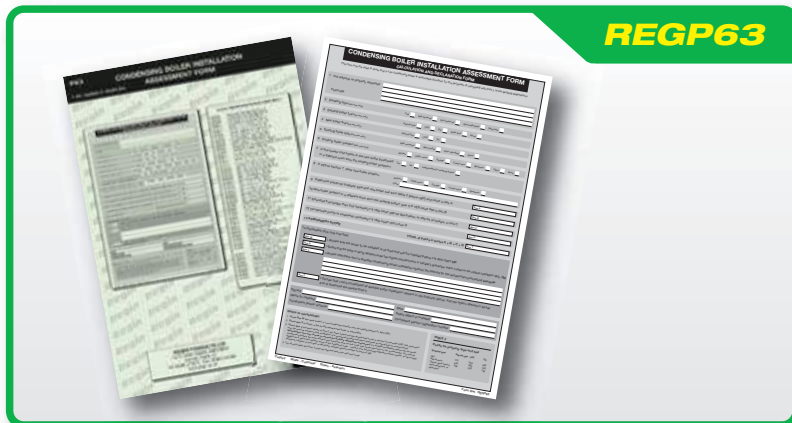

Condensing Boiler Installation Assessment Form

50 reports in duplicate

- Record, where applicable, that it would be reasonable to install a non-condensing boiler.



Central Heating Inspection/Commissioning Report

50 reports in duplicate

- Report tests and checks while commissioning a central heating boiler. Also ideal for surveying an existing central heating system.

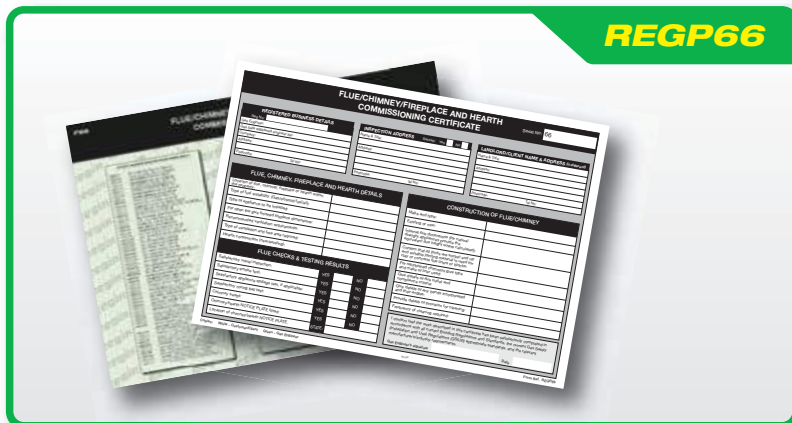

Flue/Fireplace Commissioning Certificates

20 reports in duplicate

- To enable gas operatives to meet the requirements of Approved Document 'J' of the Building Regulations.

**Commercial Servicing/
Commissioning Report**

50 reports in duplicate

- Record essential checks and tests carried out while commissioning/servicing commercial appliances.

REGPC1

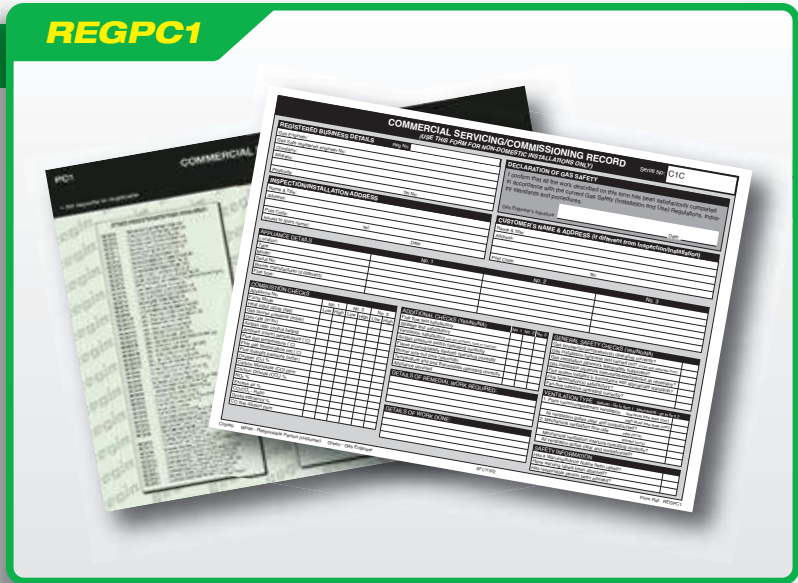

**Commercial Gas Testing
and Purging Record Pad**

50 reports in duplicate

- Accurately record details of strength testing, tightness testing and purging procedures.

REGPC2

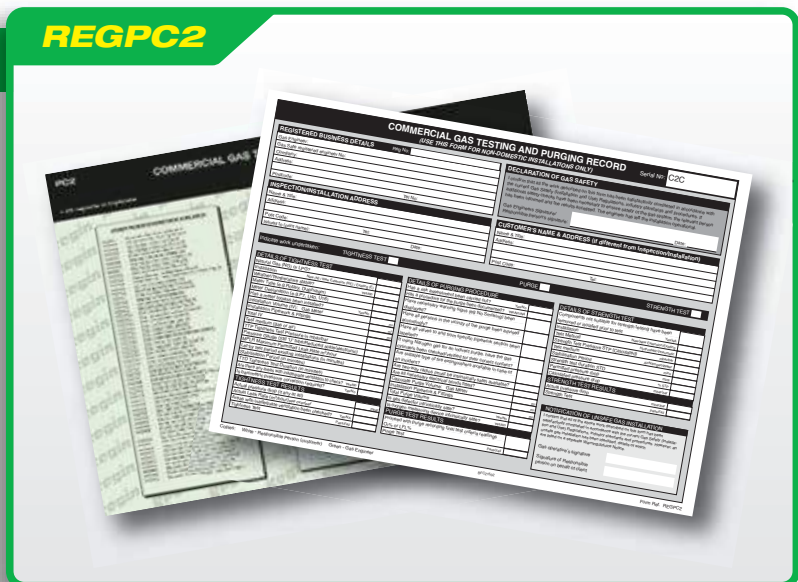

**Commercial Gas
Installation Safety Report**

50 reports in duplicate

- Record details of a commercial gas safety inspection.

REGPC3

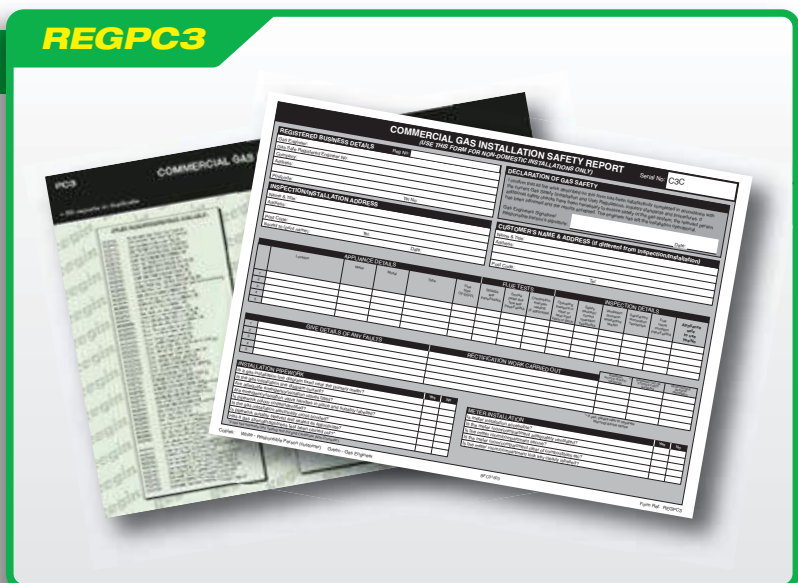

Report Pads



REGP70

Dry Pipe Pressure Test Certificates

50 reports in duplicate

- For use with *REGK10* Dry Pipe Pressure Test Kit.



REGP71

Chimney/Flue Notice Pack

- Kit comprises:
 - 1 x *REGP66* Flue/Fireplace Commissioning Certificates
 - 20 x *REGP33* Chimney/Hearth Notice Plates
 - 1 x permanent marker
 - 1 x 3m roll double sided foam tape

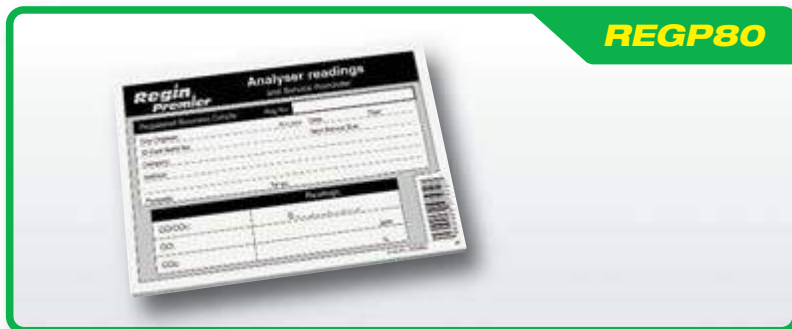

REGP80

Analyser Readings Record Pad

50 copies in duplicate

- Top copy is self adhesive.
- Also acts as an Annual Service Reminder.

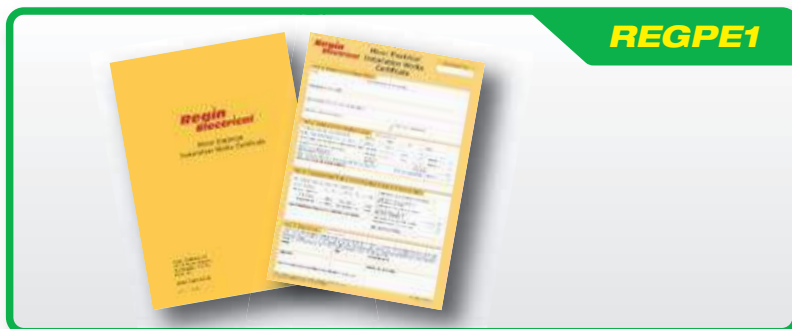

REGPE1

Minor Electrical Installation Works Certificate

36 reports in duplicate

- Report additions and alterations to an electrical installation which does not include the addition of a new circuit.



REGPE2

Electrical Installation Certificate

18 two part reports in duplicate

- Report the initial certification of a new installation in a single dwelling or the alterations and additions to an existing installation.

Oil Firing Installation Completion Report Pad

REGOCD10

50 reports in duplicate

- Record compliance with building, health, safety and efficiency regulatory requirements and manufacturers installation instructions.
- The report gives the information needed for inspecting and commissioning the installation.

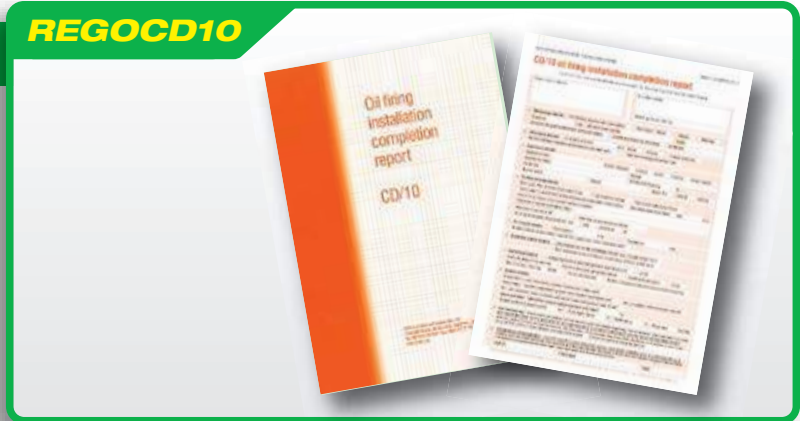

Oil Firing Service & Commissioning Report Pad

REGOCD11

50 reports in duplicate

- Provides written evidence of service/maintenance confirming the condition of the appliance and installation, any non-conformities and any remedial work required to bring the installation up to current regulations/standards.

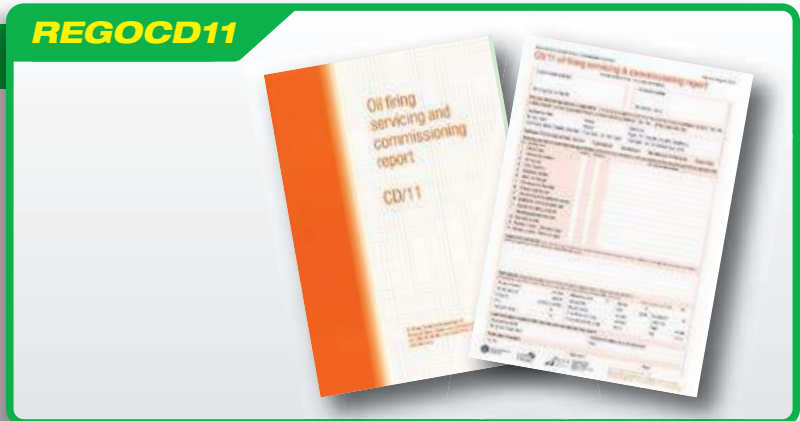

Oil Condensing Boiler Installation Report Pad

REGOCD30

50 reports in duplicate

- This form may be used to show that a Non-Condensing Boiler is reasonable provision for the purposes of complying with Part L of the Building Regulations in England, Wales, Scotland, Northern Ireland and the Republic of Ireland. Pad contains 50 sheets.

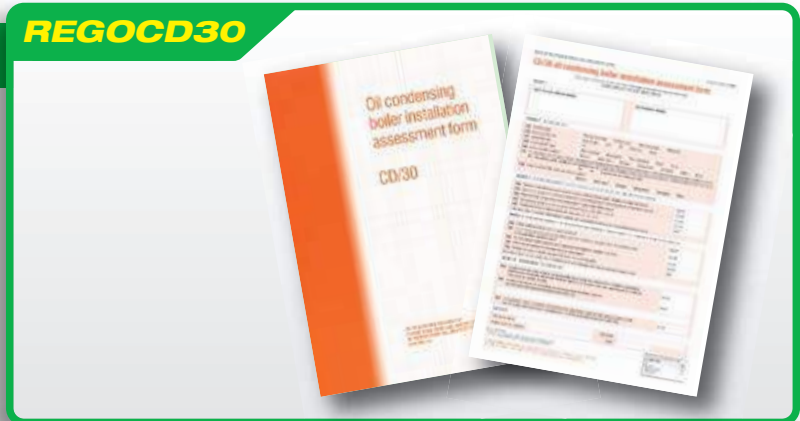

Oil Storage Risk Assessment Report Pad

REGOTI133

50 reports in duplicate

- Covers the risk of environmental damage from domestic oil storage tanks.

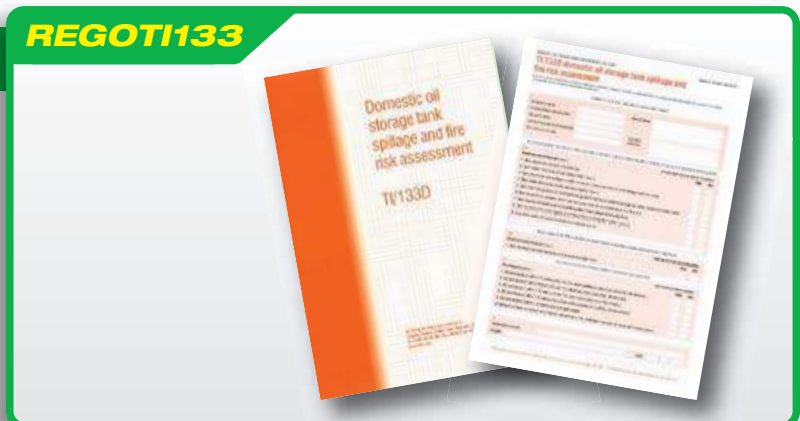

Stickers & Tags

REGP36



Danger - Do Not Use Sticker/Tag

Pack of 8 stickers/tags

- Adhesive label which sends a clear message to the gas user/responsible person that the appliance/installation is unsafe to use.
- Provides a means for engineers to fulfil the requirements placed upon them by the Gas Safety (Installation and Use) regulations 2015 (Edition 7) to notify or inform responsible persons and owners of premises/appliances of safety defects and dangers.
- Cable ties provided.
- Measures approx. 120mm x 100mm.
- **Replaces:**
 - REGP30** - Warning Appliance Unsafe Sticker
 - REGP31** - Warning Appliance Unsafe Tag
 - REGP37** - At Risk Sticker
 - REGP38** - Immediately Dangerous Sticker

NEW

For all the latest products from Regin visit our **BRAND NEW** website:
www.regin.co.uk

Important - Compartment Sticker

Pack of 8 stickers

- Warns of the dangers of blocking ventilation and storing items in compartments and airing cupboards.
- Measures approx. 100mm x 125mm.

REGP15



Gas Emergency Control Sticker

Pack of 8 stickers

- Identifies gas emergency control valves and provides clear and concise instructions to follow.
- Measures approx. 138mm x 85mm.

REGP40



Gas Isolation Valve Sticker

Pack of 8 stickers

- Measures approx. 138mm x 85mm.

REGP43



Uncommissioned Appliance Tag

Pack of 8 tags

- Identifies uncommissioned gas appliances and installations.
- Cable ties provided.
- Measures approx. 139mm x 85mm.

REGP44



Stickers & Tags

REGP39



Gas Valve Location Sticker

Pack of 8 stickers

- Sticker to clearly identify the location of the Gas Emergency Control Valve.
- Measures approx. 110mm x 70mm.

REGP05



Gas Appliance Serviced Tag

Pack of 8 tags

- Provides installation and service information.
- For situations where an adhesive label cannot be used.
- Cable ties provided.
- Measures approx. 100mm x 125mm.

REGP10



Gas Appliance Serviced Sticker

Pack of 8 stickers

- Provides installation and service information.
- Service due reminder.
- Measures approx. 100mm x 125mm.

REGP34



Caution Very Hot Water Sticker

Pack of 8 stickers

- Measures approx. 77mm x 52mm.

REGP41



5 Minute Hot Water Warning Sticker

Pack of 8 stickers

- Measures approx. 90mm x 84mm.

Electrical Bonding Stickers

Pack of 8 stickers

- Adhere, where appropriate, to an appliance in order to warn of the lack of equipotential cross bonding of the gas installation.
- Measures approx. 102mm x 69mm.

REGP11



Flammable Gas Warning Diamond

Pack of 1 sticker

- Internationally recognised symbol required on vehicles.
- Self adhesive vinyl.
- Measures approx. 100mm x 100mm.

REGP01



Compressed Gas Warning Diamond

Pack of 1 sticker

- Internationally recognised symbol required on vehicles.
- Self adhesive vinyl.
- Measures approx. 100mm x 100mm.

REGP02



Warning No Tools In Van Sticker

Pack of 1 sticker

- Measures approx. 184mm x 104mm.

REGP42



Chimney/Hearth Notice Plates

Pack of 10 Notice Plates

- 145mm x 90mm plastic with pre-drilled holes.
- To comply with the requirements of Building Regulations.
- Complete with permanent marker.
- Measures approx. 145mm x 90mm.

REGP33



Electrical Stickers & Tags



Warning Do Not Use Tag

Pack of 8 tags

- Ensure that an electrically unsafe appliance/equipment/installation is brought to the attention of the user and requires remedial work, or further investigation.



Warning Do Not Use Sticker

Pack of 8 stickers

- Ensure that an electrically unsafe appliance/equipment/installation is brought to the attention of the user and requires remedial work, or further investigation.



Warning Disconnection Sticker

Pack of 8 stickers

- Remind electrically competent persons to disconnect the electrical supply before removing electrical access covers.



Danger Live Terminals Sticker

Pack of 8 stickers

- Alerts to the fact that live terminals are present within an enclosure.



Danger 230 Volts Sticker

Pack of 8 stickers

- Warns of the presence of 230V.



Warning Isolate Supply Sticker

Pack of 8 stickers

- Remind electrically competent persons to isolate the electrical supply before removing electrical access covers.

Warning Connection Do Not Remove Sticker

Pack of 8 stickers

- Identifies the main earth safety electrical connections.

REGEP26



Caution Wiring I.D. Sticker

Pack of 8 stickers

- Draws attention to the fact that the installation contains cable colours of two different versions of BS 7671.

REGEP27



Important Inspection Reminder Sticker

Pack of 8 stickers

- Reminds the user of the importance of periodic inspections.

REGEP28



Important Safety Device Sticker

Pack of 8 stickers

- Warns of the importance of testing the protective device by affixing this highly visible label to the consumer unit.

REGEP29



Warning Isolation Tag

Pack of 8 tags

- Quick and efficient means of identifying that the electrical supply source has been isolated.

REGEP30



Equipotential Warning Tag

Pack of 8 tags

- Advise the location of a property's equipotential bond connection for the gas supply.

REGEP31



Paint Marker Pens



Regin Products Ltd are the Exclusive distributor of Ambersil paint marker pens to the heating & plumbing industry.

Paint Marker Pens

Fast drying, multi-surface, paint marker pens

Paint Marker Pens can be used exactly like regular ink permanent markers, but without the drawbacks typically associated with them. The acrylic paint is highly tenacious, able to write on almost any surface, and on any substrate colour. The very high opacity ensures outstanding colour vibrancy and visibility, and the advanced pigment technology delivers very long lasting, zero fade performance. Tenacious resin binds paint to the writing surface almost eliminating the problems associated with accidental rub-off and will not wash off with water/rain.

- Excellent opaque coverage, even on dark surfaces.
- Fast drying.
- Durable tip with valve action to prevent excess paint flow.
- Medium thickness point (∅ 3mm).
- Easy, accurate application.
- Multi-surface. Can be used on: metal, rubber, glass, textile, paper, enamel, plastic, cardboard, tiles, wood and many more.

● Colours available:

- **REGM50 Yellow:** for Gas Pipes
- **REGM51 Red:** for Hot Water Pipes
- **REGM52 Blue:** for Cold Water Pipes
- **REGM53 Black:** for Waste Pipes and general purpose



Do Not Operate Plate

Pack of 8 notice plates

- Approx. 80mm x 150mm plastic with pre-drilled hole.
- Clearly visible notice plate.
- Made from hard wearing plastic.
- Cable ties supplied.

REGP95



Emergency Control Valve Plate

Pack of 8 location plates

- Approx. 98mm x 66mm plastic with pre-drilled hole.
- Clearly visible notice plate.
- Made from hard wearing plastic.
- Cable ties supplied.

REGP96



Gas Isolation Valve Plate

Pack of 8 location plates

- Approx. 98mm x 66mm plastic with pre-drilled hole.
- Clearly visible notice plate.
- Made from hard wearing plastic.
- Cable ties supplied.

REGP97



Emergency Control Valve Location Plate

Pack of 8 location plates

- Approx. 98mm x 66mm plastic with pre-drilled hole.
- Clearly visible notice plate.
- Made from hard wearing plastic.
- Cable ties supplied.

REGP98



Meter Housing Key I.D. Plate

Pack of 8 location plates

- Approx. 98mm x 66mm plastic with pre-drilled hole.
- Clearly visible notice plate.
- Made from hard wearing plastic.
- Cable ties supplied.

REGP99



Solder Mats

REGY01



TurboJell™

TurboJell™ Heat Dissipating and Flame Retardant Spraygel

- Great Value 500ml Handy size.
- Heat-dissipating, flame-retardant gel, developed to dramatically reduce heat transfer during soldering, brazing and welding.
- Helps protect against scorching of materials, loosening of existing joints and damaging of sensitive components.
- Reduces risk of fire by protecting surfaces and dissipating heat.
- Sticks to all surfaces for maximum protection.
- Suitable for copper, steel and aluminium pipework.
- Odourless, colourless and non-corrosive.

REGY12

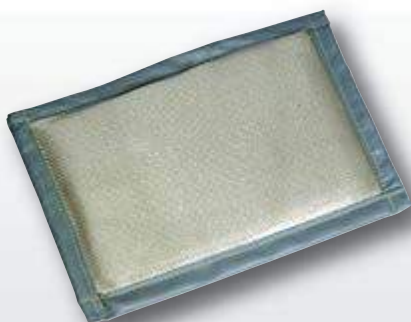

Premier Solder Mat

1300°C

- 29 cm x 19 cm.
- Withstands temperatures of up to 1300°C.
- High quality construction.
- Longer lasting.

REGY10

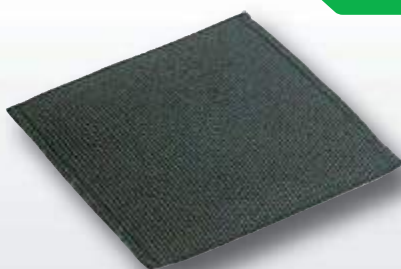

Turbo Pad

1000°C

- Approx. 23 cm x 23 cm.
- Withstands temperatures of up to 1000°C.
- Filled mat suitable for use with turbo torches.

REGY05

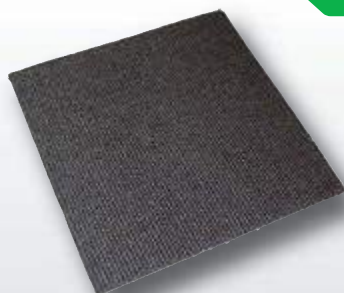

Solder Mat

600°C

- Approx. 25 cm x 25 cm.
- Withstands temperatures of up to 600°C.
- Economical DIY type mat.

Premier Professional Fuse Kit

- A comprehensive 180 piece kit containing 20 types of glass and ceramic quick blow and anti-surge fuses suitable for heating installers.
- Measures approx. 238mm x 175mm.
- Replenishment of all fuses available via our Bits'n'Bolts range (see page 146).

<p>20mm Quick Blow Glass (10) 500mA REGQ138</p>	<p>20mm Quick Blow Glass (10) 1A REGQ140</p>	<p>20mm Quick Blow Glass (10) 2A REGQ141</p>	<p>20mm Quick Blow Glass (10) 3.15A REGQ142</p>	<p>20mm Quick Blow Glass (10) 4A REGQ144</p>	<p>32mm Quick Blow Glass (10) 500mA REGQ151</p>
<p>Premier Professional Fuse Kit</p> <p>A comprehensive 180 piece kit containing 20 types of glass and ceramic quick blow and anti-surge fuses suitable for heating engineers.</p>					
<p>32mm Quick Blow Glass (10) 1A REGQ152</p>	<p>32mm Quick Blow Glass (10) 1.5A REGQ153</p>	<p>32mm Quick Blow Glass (10) 2A REGQ154</p>	<p>32mm Quick Blow Glass (10) 3A REGQ155</p>	<p>25mm Ceramic (10) 3A REGQ145</p>	<p>25mm Ceramic (10) 3A REGQ145</p>
<p>25mm Ceramic (10) 5A REGQ147</p>	<p>25mm Ceramic (10) 13A REGQ149</p>	<p>20mm Anti-Surge Glass (10) 1A REGQ156</p>	<p>20mm Anti-Surge Ceramic (5) 1A REGQ150</p>	<p>20mm Anti-Surge Glass (10) 1.25A REGQ159</p>	<p>20mm Anti-Surge Glass (10) 3.15A REGQ143</p>

Regin Products Ltd, 10/12 Tower Square, Huntingdon, Cambs, PE29 7DT Tel: 01480 412415 Fax: 01480 457484 www.regin.co.uk

REGK07



Boiler First Aid Kit

- 28 commonly used fixings for a wide range of major boiler manufacturer's appliances with a further 4 Regin products needed for everyday service work. Supplied in a high quality Regin/Raaco assorter case.
- Measures approx. 335mm x 240mm.
- Kit comprises:

<p>Steel Pan Head Screws (10) M5 x 25 REG005</p>	<p>Steel Pan Head Screws (15) M5 x 25 REG004</p>	<p>Steel Pan Head Screws (20) M5 x 16 REG006</p>	<p>C/F Steel Wing Nuts (10) M5 B2P REG007</p>	<p>C/F Steel Wing Nuts (10) M4 B2P REG008</p>	<p>Steel Pan Head Screws (20) M4 x 16 REG003</p>	<p>Steel Pan Head Screws (20) M4 x 10 REG002</p>	<p>Brass Test Nipples (2) 1/8" BSP REG010</p>
<p>Steel Pan Head Screws (10) M5 x 16 REG005</p>	<p>C/F Steel Full Nuts (30) M5 x B2P REG001</p>	<p>Boiler First Aid Kit</p> <p>28 commonly used fixings for a wide range of major boiler manufacturer's appliances with a further 4 Regin products needed for everyday service work.</p>		<p>Steel S/Tap Pan Screws (30) 1/2" x 8 B2P REG002</p>	<p>Steel S/Tap Pan Screws (30) 1/2" x 6 B2P REG001</p>	<p>Steel S/Tap Pan Screws (30) 3/4" x 8 B2P REG002</p>	<p>Steel S/Tap Pan Screws (30) 3/4" x 6 B2P REG001</p>
<p>BMS Steel Washers (30) M4 Flat B2P REG000</p>	<p>8 x 'Danger Do Not Use' Stickers/Tags REG006</p>	<p>6mm Glass Sealing Yarn - 5m REG012</p>	<p>BMS Steel Washers (30) M5 Flat B2P REG001</p>	<p>Spare Nuts (5) No. 8 Angle Nut REG001</p>	<p>Heat Sink Compound 25g REG009</p>	<p>Sealing Yarn Fixing Adhesive - 30ml REG013</p>	<p>Standard Fuse (5) 25mm 3 Amp REG015</p>
<p>Fast Blow Fuse (5) 20mm 2 Amp REG016</p>	<p>Fast Blow Fuse (5) 20mm 1 Amp REG017</p>	<p>Fibre Washer (8) 1/2" REG010</p>	<p>Fibre Washer (8) 1/2" REG011</p>	<p>Red Ignition Lead Connector (10) 2.8 x 0.5mm REG020</p>	<p>Brass Olive (6) 6mm REG017</p>	<p>Spare Nuts (5) No. 8 'U' Nut REG000</p>	<p>Standard Fuse (5) 25mm 3 Amp REG015</p>

Regin Products Ltd, 10/12 Tower Square, Huntingdon, Cambs, PE29 7DT Tel: 01480 412415 Fax: 01480 457484 www.regin.co.uk

REGK05



Kits

REGK15



Engineers Electrical Kit

- 12 commonly used fuses and electrical components needed for everyday service work.
- Measures approx. 175mm x 130mm.

REGQ140 Quick Blow 20mm 1A Fuse (3)	REGQ141 Quick Blow 20mm 2A Fuse (3)	REGQ145 Standard 25mm 3A Fuse (3)	REGQ147 Standard 25mm 5A Fuse (3)
REGQ149 Standard 25mm 13A Fuse (3)	REGQ200 Blue Insulated Ring (10)	REGQ205 Blue Butt Connector (10)	REGQ210 Red Push-On Male Connector (10)
REGQ215 Red Push-On Female Connector (10)	REGQ220 Red Ignition Lead Female Connector (10)	REGQ222 P.C.B. Support Post Type 2 (3)	REGQ223 P.C.B. Support Post Type 3 (3)

REGK17



Engineers Fuse Kit

- 12 commonly used fuses needed for everyday service work.
- Measures approx. 175mm x 130mm.

REGQ138 Quick Blow Fuse 20mm 500mA (3)	REGQ140 Quick Blow Fuse 20mm 1A (3)	REGQ141 Quick Blow Fuse 20mm 2A (3)	REGQ151 Quick Blow Fuse 32mm 500mA (3)
REGQ152 Quick Blow Fuse 32mm 1A (3)	REGQ153 Quick Blow Fuse 32mm 1.5A (3)	REGQ154 Quick Blow Fuse 32mm 2A (3)	REGQ155 Quick Blow Fuse 32mm 3A (3)
REGQ156 Anti-Surge Fuse 20mm 1A (3)	REGQ145 Ceramic Fuse 25mm 3A (3)	REGQ147 Ceramic Fuse 25mm 5A (3)	REGQ149 Ceramic Fuse 25mm 13A (3)

REGK20



Engineers Mechanical Kit

- 12 commonly used screws and fixings needed for everyday service work.
- Measures approx. 175mm x 130mm.

REGQ31 1/4" x 6 S/Tap Pozi Screw (Steel) (30)	REGQ32 1/2" x 8 S/Tap Pozi Screw (Steel) (30)	REGQ70 M4 C/F Steel Wing Nut (10)	REGQ71 M5 C/F Steel Wing Nut (10)
REGQ80 No. 8 'U' Nut (5)	REGQ81 No. 8 Angle Nut (5)	REGQ82 No. 8 Folded Nut (5)	REGQ83 No. 8 Dished Nut (5)
REGQ125 4mm Olive (Pilot Tube) (6)	REGQ127 6mm Olive (Pilot Tube) (6)	REGQ160 Brass Pressure Test Nipples (2)	REGQ316 RSM Pack (Screws/ Connectors) (1)

REGK25



Engineers Olive/Washer Kit

- 12 commonly used olives and washers needed for everyday service work.
- Measures approx. 175mm x 130mm.

REGQ125 4mm Brass Olive (6)	REGQ127 6mm Brass Olive (6)	REGQ128 8mm Brass Olive (5)	REGQ129 10mm Brass Olive (5)
REGQ132 12mm Brass Olive (4)	REGQ130 15mm Brass Olive (5)	REGQ131 22mm Brass Olive (3)	REGQ112 1" Fibre Washer (3)
REGQ111 3/4" Fibre Washer (6)	REGQ110 1/2" Fibre Washer (8)	REGQ186 1" Meter Washer (5)	REGQ185 3/4" Meter Washer (5)

Plumbers Washer Kit

REQQ121 1/2" Fibre Washer Y.I.F (30)	REQQ122 1/2" Draw Off Tap Washer (20)	REQQ124 1/2" Ballvalve Seating Washer (20)	REQQ123 Rubber Bottle Trap Washer (5)
REQQ122 1/2" Cap & Lining Washer (30)	REQQ123 3/4" Cap & Lining Washer (20)	REQQ124 1/2" Shower Hose Washer (20)	REQQ125 3/4" Washing Machine Hose Washer (10)
REQQ120 1/2" Flex Tap Conn. Washer (20)	REQQ121 3/4" Flex Tap Conn. Washer (15)	REQQ120 Circulation Pump Washer (4)	REQQ111 3/4" Fibre Washer (6)

- A selection of 200 rubber and fibre washers for a wide variety of applications.
- Measures approx. 175mm x 130mm.

REGK26



Installers Service Kit

- Kit comprises:
 - Toolbox
 - 12" 'U' Gauge
 - 2m Rubber tube
 - 'U' Gauge fluid
 - 10mm Continuity bond
 - 120ml Leak detection fluid
 - 250ml Leak detection spray
 - Pressure test kit
 - 'GAS' tape
 - 'ON/OFF' tape
 - FUMAX smoke pellets (10)
 - FUMAX KS smoke pellets (10)
 - Smoke matches (75)
 - Aluminium tape 48mm x 45m
 - Danger Do Not Use stickers (8)

REGM70



Raaco Organiser Case

- Excellent organiser case for the busy tradesman.
- 25 removeable inserts.
- Measures approx. 335mm x 240mm.

REGT24



12 Compartment Organiser Case

- Excellent organiser case for the busy tradesman.
- Measures approx. 175mm x 130mm.

REGT12



O-Ring Kits

REGK21



O-Ring Kit - Imperial

A selection of 382 high quality Nitrile (NBR 70) O-Rings in 30 different imperial sizes (BS1806)

- Temperature range: -30°C to 120°C.
- Kit comprises:

REGQ701	1/8" x 1/16" (2.90mm x 1.78mm) (20)
REGQ702	5/32" x 1/16" (3.68mm x 1.78mm) (20)
REGQ703	3/16" x 1/16" (4.48mm x 1.78mm) (20)
REGQ704	7/32" x 1/16" (5.28mm x 1.78mm) (20)
REGQ705	1/4" x 1/16" (6.07mm x 1.78mm) (20)
REGQ706	5/16" x 1/16" (7.66mm x 1.78mm) (20)
REGQ707	3/8" x 1/16" (9.25mm x 1.78mm) (20)
REGQ708	3/8" x 3/32" (9.19mm x 2.62mm) (13)
REGQ709	7/16" x 3/32" (10.78mm x 2.62mm) (13)
REGQ710	1/2" x 3/32" (12.37mm x 2.62mm) (13)
REGQ711	9/16" x 3/32" (13.95mm x 2.62mm) (13)
REGQ712	5/8" x 3/32" (15.54mm x 2.62mm) (13)
REGQ713	11/16" x 3/32" (17.13mm x 2.62mm) (13)
REGQ714	3/4" x 3/32" (18.72mm x 2.62mm) (13)
REGQ715	3/4" x 1/8" (18.64mm x 3.53mm) (10)
REGQ716	13/16" x 1/8" (20.22mm x 3.53mm) (10)
REGQ717	7/8" x 1/8" (21.82mm x 3.53mm) (10)
REGQ718	15/16" x 1/8" (23.40mm x 3.53mm) (10)
REGQ719	1" x 1/8" (24.99mm x 3.53mm) (10)
REGQ720	1 1/16" x 1/8" (26.58mm x 3.53mm) (10)
REGQ721	1 1/8" x 1/8" (28.17mm x 3.53mm) (10)
REGQ722	1 3/16" x 1/8" (29.75mm x 3.53mm) (10)
REGQ723	1 1/4" x 1/8" (31.34mm x 3.53mm) (10)
REGQ724	1 5/16" x 1/8" (32.92mm x 3.53mm) (10)
REGQ725	1 3/8" x 1/8" (34.52mm x 3.53mm) (10)
REGQ726	1 7/16" x 1/8" (36.10mm x 3.53mm) (10)
REGQ727	1 1/2" x 1/8" (37.69mm x 3.53mm) (10)
REGQ728	1 1/2" x 3/16" (37.47mm x 5.33mm) (7)
REGQ729	1 5/8" x 3/16" (40.65mm x 5.33mm) (7)
REGQ730	1 3/4" x 3/16" (43.82mm x 5.33mm) (7)

O-Ring size refers to inside diameter x cross section (mm).
Quantities of each size in brackets.

O-Rings are available separately.
See pages 138 & 139 for details.



O-Ring Kit - Metric

A selection of 404 high quality Nitrile (NBR 70) O-Rings in 30 different metric sizes

- Temperature range: -30°C to 120°C.
- Kit comprises:

REGQ751	3mm x 2.0mm (18)
REGQ752	4mm x 2.0mm (18)
REGQ753	5mm x 2.0mm (18)
REGQ754	6mm x 2.0mm (18)
REGQ755	7mm x 2.0mm (17)
REGQ756	8mm x 2.0mm (17)
REGQ757	10mm x 2.0mm (17)
REGQ758	10mm x 2.5mm (14)
REGQ759	11mm x 2.5mm (14)
REGQ760	12mm x 2.5mm (14)
REGQ761	14mm x 2.5mm (14)
REGQ762	16mm x 2.5mm (14)
REGQ763	17mm x 2.5mm (14)
REGQ764	19mm x 2.5mm (14)
REGQ765	19mm x 3.0mm (12)
REGQ766	20mm x 3.0mm (12)
REGQ767	22mm x 3.0mm (12)
REGQ768	24mm x 3.0mm (12)
REGQ769	25mm x 3.0mm (12)
REGQ770	27mm x 3.0mm (12)
REGQ771	28mm x 3.0mm (12)
REGQ772	30mm x 3.0mm (12)
REGQ773	32mm x 3.0mm (12)
REGQ774	33mm x 3.0mm (12)
REGQ775	35mm x 3.0mm (12)
REGQ776	36mm x 3.0mm (12)
REGQ777	38mm x 3.0mm (12)
REGQ778	38mm x 4.0mm (9)
REGQ779	42mm x 4.0mm (9)
REGQ780	45mm x 4.0mm (9)

O-Ring size refers to inside diameter x cross section (mm).
Quantities of each size in brackets.

O-Rings are available separately.
See pages 138 & 139 for details.

REGK22



Service Aerosols & Paints

REGZ01



Premier Giant Air Duster

500ml

Regin Premier Air Duster is the perfect answer for quick and easy removal of dust and debris from inaccessible places.

- Quick & easy non-contact removal of dust & debris from:
Burner jets,
boilers,
radio & TV chassis,
variable condensers,
micro components,
keyboards,
camera lenses & shutters,
PCB's etc
- Non flammable.

REGZ07



Premier Giant Boiler Case Cleaner

500ml

Regin Premier Boiler Case Cleaner is a unique anti-static foaming cleaner based on a blend of surfactants, solvents, inhibitors and water. It has been formulated without hydrocarbon propellants and is therefore non-flammable. Ideal for cleaning stubborn or ingrained dirt from all hard surfaces. Invaluable where water is not readily available.

- Quickly & easily removes all types of dirt, grease and stains from hard surfaces and fabrics.
- Non-flammable formula anti-static foaming cleaner.
- Unrivalled in performance.

REGZ09



Premier Giant Silicone Spray

500ml. WRAS Approved

Regin Premier Silicone Spray is a general purpose, medium duty silicone lubricant, which exhibits excellent anti-stick and slip properties. Perfect for use anywhere that sticking or fusing causes problems. It is particularly useful for lubricating plastic piping.

- General purpose silicone lubricant.
- Exhibits excellent anti-stick and slip properties.
- Ideal for use where a clean, colourless lubricant is required.
- Safe to use on wood, glass, fabrics, metals, most plastics, rubbers and hard surfaces.

Air Duster

150ml

- For quick and easy removal of dust and debris from inaccessible areas.
- Can be used to clean burner jets, PCB's, keyboards etc.
- Non flammable.

REGZ05



Spray-On Adhesive

500ml

- Gives exceptionally strong adhesion for a wide range of demanding uses.
- Ideal for use on a variety of materials such as paper, rubber, wood, cork, carpet, metal, etc.

REGZ10



Back to Black Coal Paint

Revolutionary product - The original black pigment, as used by much of the fireplace industry.

- Quick, safe and easy to use.
- OEM pigment for use in gas fires up to 1100°C.
- Typically restores up to four complete fires*.
(*200ml aerosol)
- **Available in two versions:**
 - **REGZ65** - 200ml aerosol
 - **REGZ66** - 30ml brush-on

REGZ65



REGZ66



Leak Detection

REGLO1**Premier Gas Leak Detection Aerosol**

300ml

- Meets the requirements of EN14291:2004.
- Safe detection of positive leaks.
- Suitable for use with most gases.
- Compatible with most metals and plastics.
- Specially equipped with a 360° valve to enable use at all angles.
- Fast and easy application.

REGLO5**Leak Detection Fluid**

120ml

- Complete with brush for application.
- Suitable for use with most gases.
- Compatible with most metals and plastics.

REGL10**Leak Detection Atomiser**

250ml

- Pump action applicator.
- Suitable for use with most gases.
- Compatible with most metals and plastics.

Silicone Grease (WRAS Approved)

25g tube or 250g tub

- Water-repellent, non-melting, tasteless and odourless grease used for electrical insulation purposes and specific lubrication of boiler parts when in contact with potable water.
 - Temperature range: -40°C to +200°C.
 - WRAS (Water Regulations Advisory Scheme) Approved.
- Available in two sizes:
- **REGZ40** - 50g tube
 - **REGZ41** - 250g tub

REGZ40



REGZ41



Heat Sink Compound

25g

- High thermal stability silicone compound. Used to maintain a positive heat sink seal.
- Evenly dissipates heat at the probe for clamp-on and dry pocket boiler overheat thermostats.
- Temperature range: -50°C to 200°C.

REGZ20



Gas Cock Grease

50g

- Resistant to Natural Gas and LPG.
- Temperature range: 0°C to +160°C.

REGZ15



Epoxy Putty

- Bonds to and repairs most surfaces.
- Sets hard in 20 minutes and can be sanded, drilled, filed or machined.

REGZ25



Sealants etc

**REGZ31****REGZ32****Flue'n'Fire Seal 1500°C Silicate Cement**

150ml

Regin Flue'n'Fire Seal High Temperature Resistant Silicate Cement Sealant is specifically designed for permanently repairing and sealing joints, cracks and fissures in fireplaces, ovens, chimneys and other surfaces where heat resistance is required. It can also be used for the repairing and assembling of vehicle exhaust systems.

- Heat resistant to 1500°C.
- Good adhesion to metal, brick and concrete.
- Can be overpainted.
- Primers not required.
- Easy to use.
- Supplied with nozzle.
- Multi purpose.

- **Colours available:**

- **REGZ31** - Natural (medium brown)
- **REGZ32** - Black

REGZ35**REGZ36****REGZ37****High Temperature Silicone Sealant**

310ml

- A general purpose silicone with a high temperature tolerance.
- 3 colours available.
- Withstands temperatures of up to 300°C (REGZ36 - 225°C).
- Provides excellent adhesion to a wide range of surfaces, including metal, glass and glazed ceramics.
- Cures at room temperature.
- Remains flexible from -60°C to +300°C (REGZ36 - 225°C).

- **Colours available:**

- **REGZ35** - White
- **REGZ36** - Clear
- **REGZ37** - Black

Firestop Intumescent White Sealant

310ml

- Water based acrylic.
- 4 hour fire rated.
- Can be overpainted.
- High density acoustic sealing formula.
- BS476 pt 20. ISO 11600.
- White in colour.
- Minimum 100% expansion.
- Can be used for: Pipe, cable and channel entries through walls and floors, and internal perimeter joints around fire doors.
- Can be used in contact with most building and decorating materials.
- Can be used in joints up to 25mm wide.

REGZ34



Premier Sealant Gun

- Suitable for use with all 310ml cartridges up to 220mm length including REGZ34, REGZ35, REGZ36 and REGZ37.
- Very strong construction (in order to deal with the high viscosity of our silicones and silicates).
- Includes tip cutter, just insert the nozzle of the cartridge and squeeze the handle.
- Tip piercer/cleaner for clearing sealant from dried nozzles.
- Hook end suitable for attaching to user's belt.

REGB81



Premier Stumpy Sealant Gun

- Specifically designed for REGZ31 & REGZ32 Silicate Cement (smaller for more control and access in confined spaces).
- Very strong construction (in order to deal with the high viscosity of our silicones and silicates).
- Includes tip cutter, just insert the nozzle of the cartridge and squeeze the handle.
- Tip piercer/cleaner for clearing sealant from dried nozzles.
- Hook end suitable for attaching to user's belt.
- Push rod quick release system.

REGB83



Economy Silicone Gun

- Suitable for use with 310ml cartridges.

REGB85



Sealants etc

REGM20



Gas & Water Jointing Compound

250g

- Soft setting non-petroleum based thread sealant for use with potable water and mains gas.
- WRAS Approved for use on cold potable water systems.
- Suitable for use on gas installation pipe-work as a class A, Arp and class B thread sealant as defined by BS751-2:1997.
- Non-toxic.
- 250g.

REGM08



Heldite Universal Sealant

250ml with brush applicator

HELDITE is a high performance sealant for preventing leakage of Oils, Hydraulic Fluids, Water, Steam, Gases, Coolants and Fuels (excluding ethanol) in all branches of Automotive, Auto Mechanical, Electrical and General Engineering, Plumbing, Heating and Pipeline Services.

- Flexible and adhesive.
- Completely waterproof.
- Non-abrasive, anti-corrosive and inert.
- Temperature range: -40°C to +350°C.

Not compatible with Ethanol and potable water.

REGZ22



Zoom Spout® Oiler

The original Zoom Spout Oiler

- Each Zoom Spout Oiler is filled with 4 fl oz (us) (118ml) of Unocal 76 Turbine Oil - a superior general purpose lubricating oil.
- ISO 32 grade (viscosity) oil.
- Features a flexible, telescoping, non-conductive plastic spout that extends from approx. 7½" (190mm) to 13½" (340mm).
- Flash point 210°C.
- Zoom Spout Oilers are used the world over by heating & ventilation engineers, maintenance personnel, mechanics and many more.
- Ideal for use on: Fans, Bushings, Electric motors (fractional to 5hp), Gear sets, Compressors, Linkages, Vacuum pumps, Bearings, Blowers and many more.

Central Heating Cleaner

- Disperses sludge, limescale and other deposits.
- Treats up to 10 radiators - 1 bottle for a typical heating system.
- 500ml treats up to 100 litres.
- For use in accordance with BS7593:2006
- Suitable for Mixed Metal Systems.
- Filling Kit available (REGL45).



REGL30



System Guard® Central Heating Inhibitor

- Prevents corrosion and limescale.
- Buildcert Approved.
- Treats up to 10 radiators - 1 bottle for a typical heating system.
- 500ml treats up to 100 litres.
- For use in accordance with BS7593:2006
- Suitable for Mixed Metal Systems.
- Filling Kit available (REGL45).



REGL40



Treatment Filling Kit

- For use with Regin & other suitable central heating treatments.
- Connects 500ml bottles, with 38mm standard caps, to central heating system.

REGL45



Inspection Hatches



Inspection Hatches

Inspection Hatches

Regin's range of hinged plastic inspection hatches provide a simple, low cost, high quality solution for access to building services in walls and ceilings. The plastic access panels are produced from refined high impact plastic, injection moulded into a slim profile frame, with smooth rounded corners. This provides a lightweight solution, enabling easy and rapid installation into all types of wall or ceiling construction.

- Provides the perfect solution for access to services.
- Produced from UV stable ABS, the white finish will not discolour. Surface will accommodate a paint or wallpaper finish if required.

Sizes available:

- **REGH150** - 100mm x 150mm
- **REGH150L** - 150mm x 150mm
- **REGH230** - 150mm x 230mm
- **REGH200** - 200mm x 200mm
- **REGH300** - 300mm x 300mm
- **REGH350** - 350mm x 350mm
- **REGH450** - 450mm x 450mm

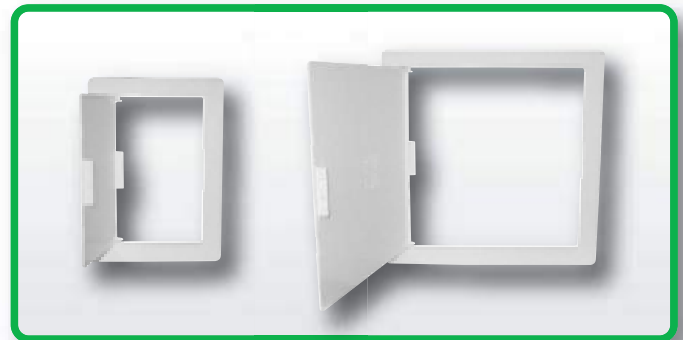

REGH300FR



Fire Rated Inspection Hatch

- Regin high quality 1-hour fire rated access panel is tested to B.S.476: Part 22:1987. It provides access into all types of wall and ceiling construction voids.
- The 1.2mm powder coated zintec steel panels have a slim profile, producing a lightweight, robust panel where access to building services is required.
- The metal frame holds a flush metal door through sliding pin hinges and is held closed with a lock (budget type).
- It is available in 300mm x 300mm size.
- As standard all doors are powder coated in white RAL 9010 with 20% gloss.
- The 25mm frame fits over the plasterboard and is visible.

Twisted Glass Yarn

- 5m
- Maximum working temperature of 550°C.
 - Asbestos free.
 - Twisted.
 - Suitable for ovens, boilers etc.
- **REGY15** - 6mm diameter.
 - **REGY20** - 10mm diameter.



Braided Glass Yarn

- 5m
- Maximum working temperature of 550°C.
 - Asbestos free.
 - Braided construction.
 - Suitable for ovens, boilers etc.
- **REGY16** - 6mm diameter.
 - **REGY21** - 10mm diameter.
 - **REGY23** - 12mm diameter.



Glass Yarn Fixative

- Heat resistant to 850°C.
 - For adhering glass yarn to metal and glass.
- **REGY25** - 30ml.
 - Complete with brush on applicator.
 - **REGY30** - 120ml.
 - Complete with nozzle applicator.
 - Large size ensures value for money.



Gloves

REGW40



Work Gloves - 'Puggy' Type

- A lightweight seamless polyester liner with a tough polyurethane coating on the palm.
- Excellent dexterity and grip with improved mechanical protection.
- EN388:2003
 Abrasion Level: 4
 Cut Level: 1
 Tear Level: 3
 Puncture Level: 1
 EN420:2003+A1:2009



REGW45



Work Gloves - Cut Level 3

- High performance HPPE fibre offering cut level 3 protection.
- An extremely light polyurethane coating to the palm and fingertips offering good mechanical protection in dry handling situations.
- Built in Sanitized® hygiene function for increased freshness.
- EN388:2003
 Abrasion Level: 4 Tear Level: 4
 Cut Level: 3 Puncture Level: 3
 EN420:2003+A1:2009



REGW46



Work Gloves - Cut Level 5

- A specialised, advanced blend of yarns provide maximum cut protection (level 5) whilst incorporating a lightweight comfortable liner.
- Nitrile foam coating improves grip and handling.
- Built in Sanitized® hygiene function for increased freshness.
- EN388:2003
 Abrasion Level: 4 Tear Level: 4
 Cut Level: 5 Puncture Level: 2
 EN420:2003+A1:2009



Work Gloves - Latex Textured Grip

- A tough general purpose glove suitable for an extensive variety of applications.
- A premium black crinkle latex coating for excellent grip and durability.
- Lightweight, soft and extremely comfortable over prolonged periods of use.
- EN388:2003
Abrasion Level: 3 Tear Level: 3
Cut Level: 1 Puncture Level: 1
EN420:2003+A1:2009

REGW41



Work Gloves - Nitrile Coating

- A lightweight nylon liner with a tough nitrile coating for excellent dexterity and abrasion resistance.
- Close fitting, knit wrist style with built in Sanitized® hygiene function for increased freshness.
- Supple nitrile palm coating gives excellent grip and provides great resistance to oils, fats and grease.
- EN388:2003
Abrasion Level: 4 Tear Level: 2
Cut Level: 1 Puncture Level: 1
EN420

REGW42



Work Gloves - PU Coating

- Medium weight nylon seamless construction.
- Tough durable polyurethane coating.
- Excellent dexterity and grip combined with improved mechanical protection.
- EN388:2003
Abrasion Level: 4 Tear Level: 2
Cut Level: 1 Puncture Level: 1
EN420

REGW43



Work Gloves - PU Fingerless

- Medium weight nylon seamless construction.
- Superb dexterity for delicate handling due to the thin PU coating.
- Thumb and first two fingers exposed for extra dexterity.
- Built in Sanitized® hygiene function for increased freshness.
- EN388:2003
Abrasion Level: 4 Tear Level: 3
Cut Level: 1 Puncture Level: 1
EN420

REGW44



Gloves

REGW26



Clean-Hands Latex Gloves

20 gloves per box

- Non-sterile pre-powdered latex gloves.
- One size fits all.
- Waterproof and impervious to dirt, dust and grease.

REGW20



Vinyl Gloves - Medium

100 gloves per box

- Non-sterile pre-powdered vinyl gloves.
- Oil resistant.

REGW21



Vinyl Gloves - Large

100 gloves per box

- Non-sterile pre-powdered vinyl gloves.
- Oil resistant.

REGW23



Nitrile Gloves

100 gloves per box

- Non-sterile pre-powdered nitrile gloves.
- Oil resistant.
- Safe, strong disposable gloves.
- 3 times the puncture resistance of latex disposable gloves.

REGST65



Coolskin Heat Resistant Gloves

1 pair

- Protects hands against temps up to 350° dry contact heat.
- Contact heat level 3.
- Cut level 5.
- 100% KEVLAR® outer layer.
- Machine washable. Soft and flexible.
- Non allergenic.
- Strong and lightweight.

Plumbers Work Mat

Available in two sizes

- The Regin Plumbers Work Mat is a durable waterproof absorbent everyday work mat giving professional consideration to customers' floors and surfaces safeguarding against possible insurance claims.
 - Featuring pipe slots on all four sides, complete with velcro anchor straps.
 - Double eyelets for hanging and securing.
 - Dirt resistant waterproof backing.
 - Water absorbent lining.
- **Two sizes available:**
 - **REGM25** - Standard:
1550mm x 680mm.
 - **REGM26** - Large:
2400mm x 1400mm.

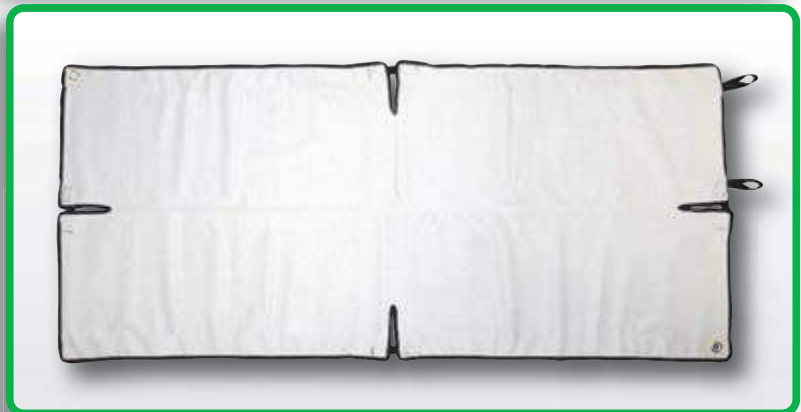

Dust Sheets & Work Mats

REGM38**Engineers Service Mat**

100cm x 73cm

- Helps protect hearths and work surfaces when removing appliances.
- Resists temperatures up to 100°C.
- Velcro pads to avoid slipping.
- Water resistant.

REGM35**4' x 4' Calico Cotton Dust Sheet**

4' x 4' (122cm x 122cm)

- Professional quality.
- 100% Natural Cotton.
- Fine weave.
- Protects furniture & floors.
- Reusable.
- Machine washable.

**Machine Washable****REGM36****12' x 9' Calico Cotton Dust Sheet**

12' x 9' (366cm x 274cm)

- Professional quality.
- 100% Natural Cotton.
- Fine weave.
- Protects furniture & floors.
- Reusable.
- Machine washable.

**Machine Washable**

12' x 9' Cotton Twill Heavyweight Dust Sheet

12' x 9' (366cm x 274cm)

- 100% Natural Cotton.
- Heavyweight Cotton Twill weave.
- For covering furniture & floors.
- For general purpose protection.
- Reusable.
- Machine washable.



Machine Washable

REGM34



6' x 3' Laminated Dust Sheet

6' x 3' (183cm x 91cm)

- Professional quality.
- Cotton with Polythene Laminate.
- Double protection.
- Helps prevent paints & liquids passing through.
- Water resistant.
- Reusable.



Laminated

REGM29



12' x 9' Laminated Dust Sheet

12' x 9' (366cm x 274cm)

- Double protection.
- Cotton with Polythene Laminate.
- Helps prevent paints & liquids passing through.
- Strong hard wearing cotton resists wear.
- Water resistant.
- Reusable.



Laminated

REGM39



Wipes & Work Wear

REGW80**Blue Paper Towel Roll**

- Approx. 100 sheets per roll.
- 3 ply.
- Highly absorbent.
- Heavy Duty.
- Each sheet measures approx. 25cm x 37cm.

REGW90**Regin PlumbPad****2 per pack**

- Each pad absorbs up to 2 litres of water.
- Absorbs excess water instantly.
- For all plumbing needs.
- Soaks up with no drips.
- Domestic leaks and spills.
- Plastic backing for no mess.
- Can be used until saturated.
- Easy to dispose of.
- Size Approx: 19cm x 44cm.

**REGW50****Heavy Duty Textured Hand Wipes****70 wipes**

- Highly absorbent dual sided textured wipes.
- Helps remove paint, grease, oil, sealants, putty, filler and adhesives.
- Each sheet measures approx. 20cm x 26cm.

Anti-Slip Clean-Soles Overshoes

- Create the right impression with your customer.
- Avoid Messy Footprints.
- 5 Pairs.
- Re-usable.
- Hard wearing.
- Non-slip sole.

REGW28



ID Card Holder

- ID card holder complete with lanyard.
- Quick release swivel clip for convenience.
- Safety release clip to prevent injury from snagging.

REGM66



Disposable Dust Masks

5 per pack

- Disposable nuisance dust mask.
- This mask should only be used to reduce discomfort caused by exposure to coarse, non-toxic particles, where the concentration does not exceed the national permissible exposure limit.

REGW10

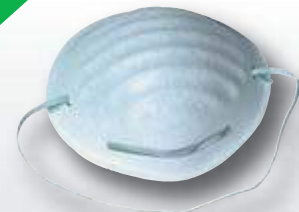

Economy Box Goggles

- Economical, comfortable soft frame, direct ventilation with a polycarbonate lens.
- Offers a high level of impact protection.
- Approved to EN166-1-49BT.

REGW70



Engineers Kneeling Mat

450 x 215 x 28mm

- Quality 28mm EVA kneeling mat ideal for the busy engineer.
- Suitable for use on hard floors.
- Lightweight.

REGW31



Batteries

**Panasonic Pro Power Alkaline Battery**

AAA (LR03) size, 1.5V

- Pack of 4 batteries.
- Reliable and dependable power.
- Ideal for high and medium drain appliances.

**Panasonic Pro Power Alkaline Battery**

AA (LR6) size, 1.5V

- Pack of 4 batteries.
- Reliable and dependable power.
- Ideal for high and medium drain appliances.

**Panasonic Pro Power Alkaline Battery**

C (LR14) size, 1.5V

- Pack of 2 batteries.
- Reliable and dependable power.
- Ideal for high and medium drain appliances.

**Panasonic Pro Power Alkaline Battery**

D (LR20) size, 1.5V

- Pack of 2 batteries.
- Reliable and dependable power.
- Ideal for high and medium drain appliances.

**Panasonic Pro Power Alkaline Battery**

9V (PP3, 6LR61) size

- 1 battery per pack.
- Reliable and dependable power.
- Ideal for high and medium drain appliances.

**Alkaline Button Battery**

AG3 (SR41) size

- Pack of 3 batteries.

Duracell Plus Power Alkaline Battery

AAA (LR03) size, 1.5V

- Pack of 4 batteries.
- Duracell, the UK's #1 Battery Brand.
- Reliable high-energy output, longer shelf life and great value for your money.

REGEDLAAA4**DURACELL****Duracell Plus Power Alkaline Battery**

AA (LR6) size, 1.5V

- Pack of 4 batteries.
- Duracell, the UK's #1 Battery Brand.
- Reliable high-energy output, longer shelf life and great value for your money.

REGEDLAA4**DURACELL****Duracell Plus Power Alkaline Battery**

C (LR14) size, 1.5V

- Pack of 2 batteries.
- Duracell, the UK's #1 Battery Brand.
- Reliable high-energy output, longer shelf life and great value for your money.

REGEDLC2**DURACELL****Duracell Plus Power Alkaline Battery**

D (LR20) size, 1.5V

- Pack of 2 batteries.
- Duracell, the UK's #1 Battery Brand.
- Reliable high-energy output, longer shelf life and great value for your money.

REGEDLD2**DURACELL****Duracell Plus Power Alkaline Battery**

9V (PP3, 6LR61) size

- 1 battery per pack.
- Duracell, the UK's #1 Battery Brand.
- Reliable high-energy output, longer shelf life and great value for your money.

REGEDLNV1**DURACELL****Alkaline Button Battery**

AG13 (SR44) size

- Pack of 2 batteries.
- Used in REGT15 Volt Sensor, REGX10 Pressure Vessel Checker & REGT11 'Bits'n'Bolts Retriever.

REGEAG13

Spares etc



REGE105

Electrical Connector with Strain Relief

3 & 5 way connectors

- For flexible, stranded and solid wires with cross-section of 0.75-4.0mm².
- Strain relief for cables with outer diameter of 5.5-12.0mm.
- Rated voltage: 250V.
- Rated current: 20A
- Complete with locking latch for added security.



REGE103

Versions available:

- **REGE105** - 5 Way Connector.
- **REGE103** - 3 Way Connector.



REGC70

Compact Condensate Pump

The Compact Condensate Pump is designed to collect condensation and discharge up to 15m. The compact design allows for ease of installation. Using internal float switches the pump automatically removes the collected condensate. The pump can be installed freestanding or wall mounted with the bracket supplied.

- Safety cut-out.
- Extremely quiet.
- Compact and discreet.
- Discharge hose included.
- 15m max. discharge head.

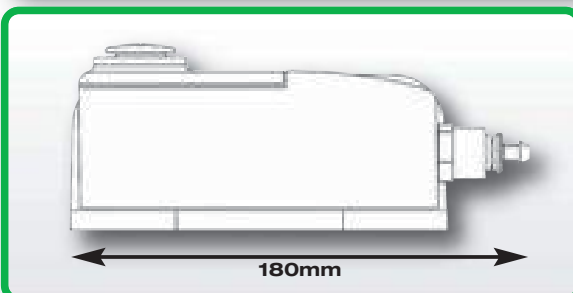

Suitable for:
 Oil & gas fired condensing boilers.
 High efficiency gas furnace.

Divertor Valve Diaphragm Kit

Genuine Giannoni replacement part

- Can be used to replace and repair faulty diaphragms in diverter valves in many makes of combination boilers.

REGC50



Ignition Lead Multi-Kit

1500mm lead & accessories

- Cut to required length.
- 2.8mm female connectors.

REGC30



Ignition Lead

- 2.8mm female connectors.

Sizes available:

- **REGC19** - 370mm long.
- **REGC20** - 450mm long.
- **REGC21** - 530mm long.
- **REGC22** - 750mm long.
- **REGC24** - 950mm long.
- **REGC25** - 1000mm long.



Spares etc

REGR11**'Tamper Proof' Radvalve Tops****Domestic**

- Fast, easy to fit and Tamper-Proof.
- No experience or special tools are required to install them.
- Fits valves up to 15mm.

REGR12**'Tamper Proof' Radvalve Tops****Commercial**

- Fast, easy to fit and Tamper-Proof.
- No experience or special tools are required to install them.
- Fits valves 1/2" to 1".

REGR18**Radiator Bleeder Set****1/2" Radiator air vent & blanking plug set**

- Vent can be opened using radiator bleed key (supplied) or a screwdriver.
- Can be rotated to change direction that air/water discharges.

REGR19**Radiator Vent Key - Brass Bar Type**

- Specially designed for bleeding trapped air from radiators.
- Fits most radiators.

Cooker Stability Chain & Hook

- Complete with chain, hook & screws.
- Approx. 400mm long.
- Comes with fittings and bracket.

REGC40



Universal Meter Adaptor Plate

Universal Fitting

- Unique patented design.
- Fits all gas meter brackets.
- Firmly secures the meter to the meter bracket.

REGR30



Analyser Replacement Filter

1 per pack

- Replacement filter for *Regin* Analysers.

REGXA5



Replacement Pipe Cutter Wheel

1 per pack

- Regin Autocut® Automatic Pipe Cutter replacement cutter wheel.

REGQ671

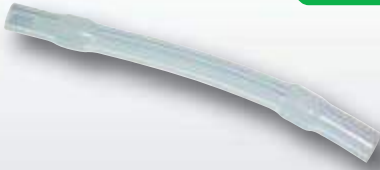

Spares etc

REGU36**Premier Gauge Replacement Stopper**

- Replacement stopper for the Regin Premier Gauge.

REGU38**Premier Gauge Replacement Screw & 'O' Ring Set**

- Replacement screw & 'O' Ring set for the Regin Premier Gauge.

- **Available in two sizes:**

- **REGU38** - Premier 45 Screw & 'O' Ring Set
- **REGU42** - Premier 60 Screw & 'O' Ring Set

REGU42**REGU39****Premier Gauge Replacement Nylon Bag**

- Replacement nylon carry case for the Regin Premier Gauge.

- **Available in two sizes:**

- **REGU39** - Premier 45 Nylon Bag
- **REGU41** - Premier 60 Nylon Bag

REGU41**REGXP102****Replacement Instrument Case**

- Replacement padded carry case.
- Suitable for a single unit or device.

Stove Range

Stove Range A comprehensive range of products specifically designed for use on wood or multi-fuel stoves, grates, flues etc	129
Stove Fan	130
Digital Wood Moisture Meter	131
Stove Pipe Thermometer	131
Heat Resistant Gloves	131
Stove Paint	132
Stove Glass Cleaner	132
Chimney & Flue Cleaner	132
Stove & Grate Polish	133
Flue & Fire Seal 1500°C	133
Back to Black Paint	133
Glass Yarn & Fixative	134
Smoke Pellets	135
Smoke Matches	135
Chimney/Hearth Notice Plates	135

Stove Range

REGST85



Heat Powered Stove Fan

The Regin Stove Range Heat Powered Stove Fan is designed to circulate the warm air that is created by a stove operating with normal surface temperature between 65°C and 345°C. The warm air is pushed out into the living area rather than just rising to the ceiling above the stove. Improved warm air circulation results in greater heat dispersion and less fuel consumption. The stove fan does not use batteries or mains power.

The specifically designed blade delivers a very broad cross section of gentle air movement.

The stove fan starts automatically and adjusts its speed with the stove's temperature. It runs faster to move more air into the room as the stove heats up, and automatically slows down and stops as the stove burns down & cools.

- Needs no electricity
- Circulates warm air throughout the room
- Burn less wood
- Silent operation.

● **Available in three colours:**

- **REGST85:** Nickel Blade
- **REGST86:** Gold Blade
- **REGST87:** Black Blade

REGST86



REGST87



Heat dispersion with Stove Fan

Simulation

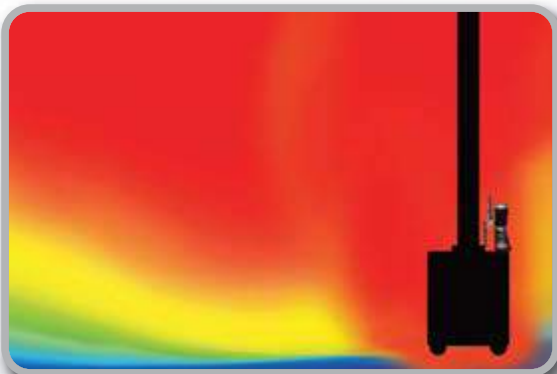

Without Stove Fan

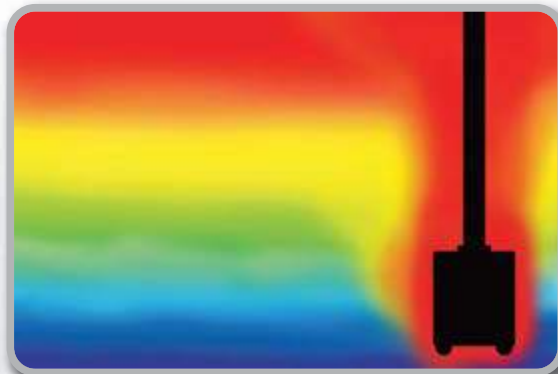

Digital Wood Moisture Meter

- Measures moisture range from: 3.0% to 40.0%.
- Large, easy-to-read display including speedometer style scale.
- Supplied in Nylon pouch.
- Low battery indication.
- Data-hold function.
- ON/OFF push-button power switch.
- Auto power-off after 15 minutes of inactivity.
- Supplied with battery.

REGST80



Stove Pipe Thermometer

- Monitor the performance of your wood or multi fuel stove.
- Easy to read.
- Attaches magnetically.
- °C and °F scales.
- Improves stove's efficiency.

REGST75



Stove Heat Resistant Gloves

1 pair

- Protects hands against temps up to 350° dry contact heat.
- Contact heat level 3.
- Cut level 5.
- 100% KEVLAR® outer layer.
- Machine washable. Soft and flexible.
- Non allergenic.
- Strong and lightweight.

REGST65



Stove Range



REGST10



REGST15

Stove Paint - Black

Regin Premier Stove Range Stove Paint is a very high temperature corrosion resistant non-clogging paint for use on wood or multi-fuel stoves, grates, flues, etc.

- Matt finish.
- Heat resistant to 650°C.
- **Available in two sizes:**
- **REGST10:** 250ml
- **REGST15:** 450ml



REGST20

Stove Glass Cleaner

320ml

Regin Premier Stove Range Glass Cleaner clings to surfaces to remove creosote and tar deposits.

- For use on wood, coal or oil burning equipment, glass firescreens etc.
- Use regularly to avoid stubborn accumulations of tar/creosote deposits on glass doors.
- Can be used on glass oven doors as a de-greaser.



REGST50

Chimney & Flue Cleaner

750g tub

- Regin Stove Range Chimney & Flue Cleaner attacks and reduces creosote and tar deposits that have built up on flue linings.
- Improves your flue's health & efficiency.
- With regular use these hard deposits become crystallised and either fall off or are removed during chimney sweeping.

Stove & Grate Polish

170g tub

Regin Premier Stove Range Stove & Grate Polish is a water based polish formulated to cover minor scratches and rust, leaving an even finish which, when dry, does not rub off.

REGST01



Flue'n'Fire Seal 1500°C

Regin Flue'n'Fire Seal High Temperature Resistant Silicate Cement Sealant is specifically designed for permanently repairing and sealing joints, cracks and fissures in fireplaces, ovens, chimneys and other surfaces where heat resistance is required. It can also be used for the repairing and assembling of vehicle exhaust systems.

- Heat resistant to 1500°C.
 - Good adhesion to metal, brick and concrete.
 - Can be overpainted.
 - Primers not required.
 - Easy to use.
 - Supplied with nozzle.
 - Multi purpose.
- **Available in two colours:**
 - **REGZ31: Natural**
 - **REGZ32: Black**

REGZ31



REGZ32

Back to Black Coal Paint

Revolutionary product - The original black pigment, as used by much of the fireplace industry.

- Quick, safe and easy to use.
 - OEM pigment for use in gas fires up to 1100°C.
 - Typically restores up to four complete fires*.
*(200ml aerosol)
- **Available in two versions:**
 - **REGZ65: 200ml aerosol**
 - **REGZ66: 30ml brush-on**

REGZ65



REGZ66

Stove Range



Stove Rope - Braided

High temperature sealing yarn for ovens, boilers, flues and general heating applications.

- 1.5 Metre Pack.
- Max Temp 550°C.
- Asbestos free braided yarn.
- **Available in three diameters:**
 - **REGST32:** 6mm
 - **REGST34:** 9mm
 - **REGST36:** 12mm



Stove Rope & Fixative Kit

Convenient kit containing 1.5m of Braided Stove Rope and a bottle of Stove Rope Fixative.

- **Available in three diameters:**
 - **REGST40:** 6mm
 - **REGST42:** 9mm
 - **REGST44:** 12mm

All come complete with a 30ml bottle of **Stove Rope Fixative REGST25**



REGST25



REGST30

Stove Rope Fixative

- Heat resistant to 850°C.
- For adhering glass yarn to metal and glass.
- **REGST25 - 30ml.**
 - Complete with brush on applicator.
- **REGST30 - 120ml.**
 - Complete with nozzle applicator.
 - Large size ensures value for money.

Stove Range Smoke Pellets

Pack of 10 pellets

- BS5440 Part 1 compliant.
- Approx. 30 second burn time.
- Produces an estimated 5 cubic metres of smoke with an ideal density for flue testing.
- Encapsulated for ease of use and disposal.

REGST02



Stove Range Smoke Matches

Tub of 25 matches

- Approx. 15 second burn time.
- Supplied in a resealable water resistant tub.
- Produces a white smoke with an ideal density for spillage testing.
- Average contents: 25 matches.

REGST03



Chimney/Hearth Notice Plate

- Pack of 10 notice plates.
- Approx. 145mm x 90mm plastic with pre-drilled holes.
- To comply with the requirements of Building Regulations.
- Made from hard wearing plastic.
- Complete with permanent marker.

REGP33



Regin



Bits 'n' Bolts

O-Rings Imperial & Metric Nitrile O-Rings	138
Washers Fibre Washers, Pump Washers, Steel Washers etc	140
Spire Nuts Spire Nuts, Control Knob Clips etc	144
Nuts Brass Nuts, Wing Nuts, Thermocouple Split Nuts etc	145
Fuses Quick Blow Fuses, Anti-Surge Fuses etc	146
Miscellaneous Pressure Test Nipples, Knife Blades, Radiator Keys, Cable Ties, Superglue, etc	147
PCB Support Posts Printed Circuit Board Support Posts	152
Screws Pan Screws, Self Tapping Screws	153
Electrical Connectors Push-In Connectors, Pre-Insulated Terminals, Connector Strips etc	154
Tapes & Labels PVC Insulation Tapes, Pipe Labels	158
Olives Brass Olives	159

O-Rings



O-Rings - Imperial

High quality Nitrile (NBR 70) O-Rings in Imperial sizes (BS1806)

- Temperature range: -30°C to 120°C.
- **REGQ701** - 1/8" x 1/16" (2.90mm x 1.78mm) (20)
- **REGQ702** - 5/32" x 1/16" (3.68mm x 1.78mm) (20)
- **REGQ703** - 3/16" x 1/16" (4.48mm x 1.78mm) (20)
- **REGQ704** - 7/32" x 1/16" (5.28mm x 1.78mm) (20)
- **REGQ705** - 1/4" x 1/16" (6.07mm x 1.78mm) (20)
- **REGQ706** - 5/16" x 1/16" (7.66mm x 1.78mm) (20)
- **REGQ707** - 3/8" x 1/16" (9.25mm x 1.78mm) (20)
- **REGQ708** - 3/8" x 3/32" (9.19mm x 2.62mm) (13)
- **REGQ709** - 7/16" x 3/32" (10.78mm x 2.62mm) (13)
- **REGQ710** - 1/2" x 3/32" (12.37mm x 2.62mm) (13)
- **REGQ711** - 9/16" x 3/32" (13.95mm x 2.62mm) (13)
- **REGQ712** - 5/8" x 3/32" (15.54mm x 2.62mm) (13)
- **REGQ713** - 11/16" x 3/32" (17.13mm x 2.62mm) (13)
- **REGQ714** - 3/4" x 3/32" (18.72mm x 2.62mm) (13)
- **REGQ715** - 3/4" x 1/8" (18.64mm x 3.53mm) (10)
- **REGQ716** - 13/16" x 1/8" (20.22mm x 3.53mm) (10)
- **REGQ717** - 7/8" x 1/8" (21.82mm x 3.53mm) (10)
- **REGQ718** - 15/16" x 1/8" (23.40mm x 3.53mm) (10)
- **REGQ719** - 1" x 1/8" (24.99mm x 3.53mm) (10)
- **REGQ720** - 1 1/16" x 1/8" (26.58mm x 3.53mm) (10)
- **REGQ721** - 1 1/8" x 1/8" (28.17mm x 3.53mm) (10)
- **REGQ722** - 1 3/16" x 1/8" (29.75mm x 3.53mm) (10)
- **REGQ723** - 1 1/4" x 1/8" (31.34mm x 3.53mm) (10)
- **REGQ724** - 1 5/16" x 1/8" (32.92mm x 3.53mm) (10)
- **REGQ725** - 1 3/8" x 1/8" (34.52mm x 3.53mm) (10)
- **REGQ726** - 1 7/16" x 1/8" (36.10mm x 3.53mm) (10)
- **REGQ727** - 1 1/2" x 1/8" (37.69mm x 3.53mm) (10)
- **REGQ728** - 1 1/2" x 3/16" (37.47mm x 5.33mm) (7)
- **REGQ729** - 1 5/8" x 3/16" (40.65mm x 5.33mm) (7)
- **REGQ730** - 1 3/4" x 3/16" (43.82mm x 5.33mm) (7)

O-Rings - Metric

High quality Nitrile (NBR 70) O-Rings in metric sizes

- Temperature range: -30°C to 120°C.

- **REGQ751** - 3mm x 2.0mm (18)
- **REGQ752** - 4mm x 2.0mm (18)
- **REGQ753** - 5mm x 2.0mm (18)
- **REGQ754** - 6mm x 2.0mm (18)
- **REGQ755** - 7mm x 2.0mm (17)
- **REGQ756** - 8mm x 2.0mm (17)
- **REGQ757** - 10mm x 2.0mm (17)
- **REGQ758** - 10mm x 2.5mm (14)
- **REGQ759** - 11mm x 2.5mm (14)
- **REGQ760** - 12mm x 2.5mm (14)
- **REGQ761** - 14mm x 2.5mm (14)
- **REGQ762** - 16mm x 2.5mm (14)
- **REGQ763** - 17mm x 2.5mm (14)
- **REGQ764** - 19mm x 2.5mm (14)
- **REGQ765** - 19mm x 3.0mm (12)
- **REGQ766** - 20mm x 3.0mm (12)
- **REGQ767** - 22mm x 3.0mm (12)
- **REGQ768** - 24mm x 3.0mm (12)
- **REGQ769** - 25mm x 3.0mm (12)
- **REGQ770** - 27mm x 3.0mm (12)
- **REGQ771** - 28mm x 3.0mm (12)
- **REGQ772** - 30mm x 3.0mm (12)
- **REGQ773** - 32mm x 3.0mm (12)
- **REGQ774** - 33mm x 3.0mm (12)
- **REGQ775** - 35mm x 3.0mm (12)
- **REGQ776** - 36mm x 3.0mm (12)
- **REGQ777** - 38mm x 3.0mm (12)
- **REGQ778** - 38mm x 4.0mm (9)
- **REGQ779** - 42mm x 4.0mm (9)
- **REGQ780** - 45mm x 4.0mm (9)



O-Rings also available in Kits - see page 102 & 103

Washers



REGQ115

Fibre Washer Pack

- Replacement Diverter Valve Washers.
- Pack comprises:
3 x 1/2" Fibre Washers, 3 x 3/4" Fibre Washers & 1 x 1" Fibre Washer.
- General purpose commercial non asbestos fibre material suitable for oils, fuels, low pressure steam, water and excellent resistance to gas leakage.
- Recommended max. temperature: 300°C (max. steam temp. 180°C).
- BS7531 Grade Y.
- WRAS Approved.



REGQ110

1/2" Fibre Washer

8 per pack

- See above for spec.



REGQ111

3/4" Fibre Washer

6 per pack

- See above for spec.



REGQ112

1" Fibre Washer

3 per pack

- See above for spec.



REGQ190

Circulation Pump Washer

4 per pack

- (44.95/43.95mm x 32.1/31.4mm x 2.2/1.8mm).
(outside diameter x inside diameter x thickness)

BS746 Meter Union Washer

Conforms to BS EN 549

- **REGQ185** - **3/4"** - **10 per pack.**
(25.8mm x 20.2mm x 2.4mm).
- **REGQ186** - **1"** - **10 per pack.**
(32.3mm x 25.8mm x 2.4mm).
- **REGQ187** - **1 1/4"** - **6 per pack.**
(42.5mm x 35.3mm x 2.4mm).
- **REGQ188** - **1 1/2"** - **3 per pack.**
(53.6mm x 44.3mm x 2.4mm).
- **REGQ189** - **2"** - **2 per pack.**
(71.4mm x 57.5mm x 2.4mm).

For Meter Sealing Discs - See p147

(outside diameter \pm 0.4mm x inside diameter \pm 0.4mm x thickness \pm 0.2mm)

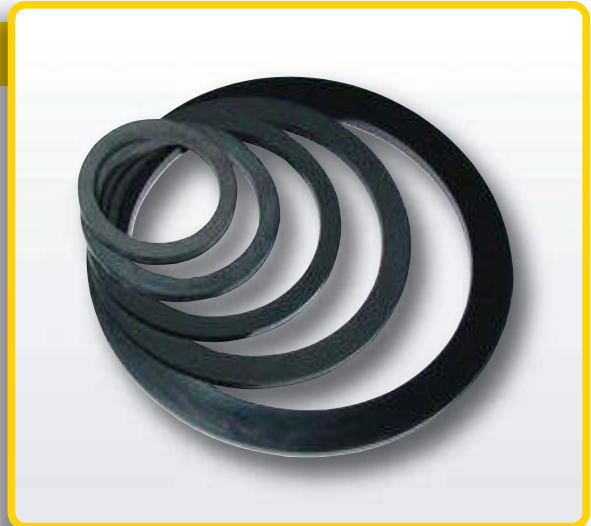
**BS746 Meter Adaptor Washer**

Conforms to BS EN 549

- **REGQ175** - **3/4"** - **6 per pack.**
(29.0mm x 21.4mm x 3.2mm).
- **REGQ176** - **1"** - **6 per pack.**
(36.5mm x 27.0mm x 3.2mm).
- **REGQ177** - **1 1/4"** - **4 per pack.**
(45.5mm x 36.5mm x 3.2mm).
- **REGQ178** - **1 1/2"** - **3 per pack.**
(56.5mm x 45.5mm x 3.2mm).
- **REGQ179** - **2"** - **2 per pack.**
(76.0mm x 58.8mm x 3.2mm).

(outside diameter \pm 0.4mm x inside diameter \pm 0.4mm x thickness \pm 0.2mm)

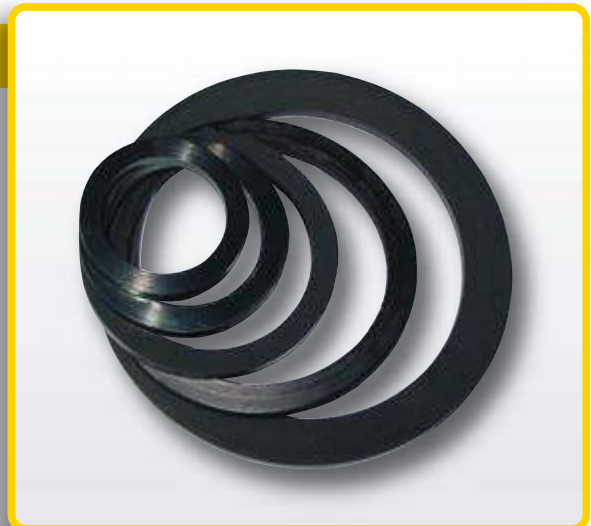
**Steel Star Washer**

30 per pack

- **REGQ100** - **M4.**
- **REGQ101** - **M5.**

**Steel Flat Washer**

30 per pack

- **REGQ90** - **M4.**
- **REGQ91** - **M5.**



Washers



REGQ120

1/2" Flex Tap Conn. Washer

20 per pack

- Non asbestos Nov30.



REGQ121

1/2" Fibre Washer Y.I.F.

30 per pack

- Hard red fibre.



REGQ122

1/2" Cap & Lining Washer

30 per pack

- Hard red fibre.



REGQ123

3/4" Cap & Lining Washer

20 per pack

- Hard red fibre.



REGQ124

1/2" Ballvalve Seating Washer

20 per pack

- Hard red fibre.

3/4" Flex Tap Conn. Washer

15 per pack

- Non asbestos Nov30.

REGQ191**1/2" Draw Off Tap Washer**

20 per pack

- Commercial rubber.

REGQ192**Rubber Bottle Trap Washer**

5 per pack

- Rubber.

REGQ193**1/2" Shower Hose Washer**

20 per pack

- Smooth rubber.

REGQ194**3/4" Washing Machine Hose Washer**

10 per pack

- Smooth rubber.

REGQ195

Spire Nuts

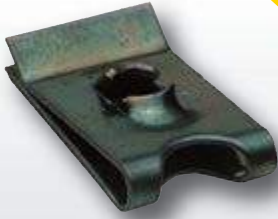

REGQ80

Spire Nut No. 8 'U' Nut

5 per pack



REGQ81

Spire Nut No. 8 Angle Nut

5 per pack

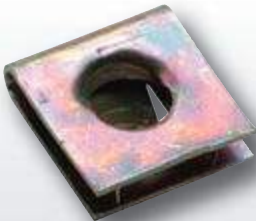

REGQ82

Spire Nut No. 8 Folded Nut

5 per pack



REGQ83

Spire Nut No. 8 Dished Nut

5 per pack

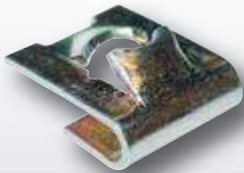

REGQ84

Spire Nut No. 6 'J' Nut

5 per pack



REGQ86

Control Knob 'D' Clip

4 per pack

M8 Hexagon Brass Nut

4 per pack

REGQ314



Steel Full Nut

30 per pack

- **REGQ50** - M4
- **REGQ51** - M5



Steel Wing Nut

- **REGQ70** - M4 - 10 per pack
- **REGQ71** - M5 - 10 per pack
- **REGQ75** - 1/4" BSW - 5 per pack



T/couple Wide Slot Split Nut

2 per pack

- **REGQ300** - M8
- **REGQ302** - M9
- **REGQ304** - M10
- **REGQ306** - 11/32"



M8 x M10 T/couple Wide Slot Split Nut

1 per pack

REGQ308



M8 x M10 T/couple Adaptor Nut

2 per pack

REGQ310



M10 T/couple Olive Nut

2 per pack

REGQ312



Fuses



Standard Fuses

Ceramic Fuses:

- **REGQ146** - 25mm 2A (2)
- **REGQ145** - 25mm 3A (3)
- **REGQ147** - 25mm 5A (3)
- **REGQ149** - 25mm 13A (3)



Quick Blow Fuses

Glass Fuses:

- **REGQ138** - 20mm 500mA (3)
- **REGQ140** - 20mm 1A (3)
- **REGQ141** - 20mm 2A (3)
- **REGQ142** - 20mm 3.15A (3)
- **REGQ151** - 32mm 500mA (3)
- **REGQ152** - 32mm 1A (3)
- **REGQ153** - 32mm 1.5A (3)
- **REGQ154** - 32mm 2A (3)
- **REGQ155** - 32mm 3A (3)

Ceramic Fuses:

- **REGQ144** - 20mm 4A (3)
- **REGQ157** - 32mm 500mA (1)
- **REGQ148** - 32mm 5A (2)



Anti-Surge Fuses

Glass Fuses:

- **REGQ136** - 20mm 630mA (3)
- **REGQ143** - 20mm 3.15A (3)
- **REGQ156** - 20mm 1A (3)
- **REGQ159** - 20mm 1.25A (3)

Ceramic Fuses:

- **REGQ150** - 20mm 1A (2)
- **REGQ158** - 32mm 1.6A (2)

Equal Compression Fitting

- 1 per pack
- 4mm fitting.

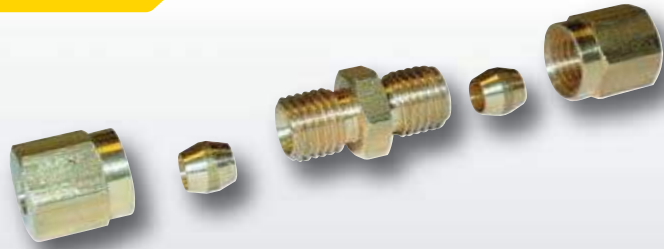
REGQ139**Brass Pressure Test Nipple**

- 2 per pack
- Test point nipples with 1/8" BSP thread.

REGQ160**Analyser Test Hole Cover**

- 10 per pack
- Self adhesive - covers unsightly holes.

REGQ170**Meter Sealing Disc**

- **REGQ180** - 3/4" diameter. 4 per pack.
- **REGQ181** - 1" diameter. 3 per pack.

For Meter Union Washers - See p141

**Jubilee Hose Clip c/w Wing Screw**

- 1 per pack
- **REGQ820** - 13-20mm diameter.
- **REGQ825** - 17-25mm diameter.
- **REGQ835** - 25-35mm diameter.



Miscellaneous

REGT11**Illuminated 'Bits'n'Bolts' Retriever**

- Heavy-duty five section telescopic pick-up tool.
- Large Ø14mm magnet with 3.6kg capacity and recessed LED to illuminate target area.
- Textured, contoured handle for added comfort.
- Knurled twist on/off switch for ease of use.
- Extends to approx: 81cm (32") in length.

REGQ600**Neon Mains Test Screwdriver****1 per pack**

- Contains a neon indicator in the clear plastic handle which lights up when the point of the screwdriver is touched on voltages between 220–250V and your thumb is forming an earth contact with the metal stud set into the top of the handle.
- The mains tester has a plastic insulating sleeve on the screwdriver blade.

REGQ601**'Z' Driver - Angled Screwdriver****No.2/6mm**

- Phillips and slotted head driver.
- Overall length approx. 145mm.

REGQ621**Heavy Duty Knife Blades****pack of 10 blades**

- Supplied in a safety dispenser.

Radiator Bleed Key

2 per pack

- Solid brass radiator bleed key suitable for most radiator bleed nipples.

REGQ615**Meter Box Key**

2 per pack

- Pack of 2 plastic meter box keys.

REGQ616**Flux Brush**

1 per pack

- Overall length approx. 175mm.

REGQ619**Steel Wire Mini Brush**

1 per pack

- Overall length approx. 175mm.

REGQ620**Cable Ties**

- **REGQ610** - 140mm long. 50 per pack.
- **REGQ611** - 250mm long. 30 per pack.



Miscellaneous

**REGQ237****Radiator Clamp Kit**

1 per pack

- Specifically designed to allow a convenient and easy method of complying with the current IEE wiring regulations.
- Easily used in earthing applications with wet filled radiators, steel kitchen sinks, ducting, suspended ceilings or any other metalwork that offers a 'fin' contact area.

**Steel Earthing Clamps**

1 per pack

- For 12-32mm diameter pipes.
- **REGQ235** - **Red Steel Earthing Clamp.**
For dry conditions.
- **REGQ236** - **Blue Steel Earthing Clamp.**
For areas prone to moisture.

**REGQ605****Cable Fasteners**

5 per pack

- Self adhesive cable fasteners.
- For cables up to 8mm diameter.

**REGQ660****Cotter Pin**

20 per pack

- M2 size.

**REGQ671****Replacement Pipe Cutter Wheel**

1 per pack

- Regin Autocut® Automatic Pipe Cutter replacement cutter wheel.

Disposable Anti-Static Wrist Strap

- For removing potentially damaging static charges when installing or removing sensitive electronics such as P.C.B's during routine maintenance and repairing of appliances.

REGQ238



Flat Cable Clips

20 per pack

Types available:

- **REGQ608** - Cable Clips - 2.5mm
- **REGQ609** - Cable Clips - 6mm



Junior Hacksaw Blade

10 per pack

- Overall length approx. 150mm.

REGQ625



Superglue

1 per pack

- 20g bottle.

REGQ680



Sealant Nozzles

- A simple solution for blocked nozzles.
- For use with most 310ml and 150ml sealant type tubes.
- 4 nozzles per pack.

REGQ602



PCB Support Posts



PCB Support Post Type 1

3 per pack



PCB Support Post Type 2

3 per pack



PCB Support Post Type 3

3 per pack



PCB Support Post Type 4

3 per pack

NEW



**For all the latest products
from Regin visit our
BRAND NEW website:**

www.regin.co.uk

Steel Pozi Pan Screw

- **REGQ01** - M3 x 6 - 30 per pack
- **REGQ02** - M4 x 10 - 20 per pack
- **REGQ03** - M4 x 16 - 20 per pack
- **REGQ09** - M5 x 8 - 20 per pack
- **REGQ04** - M5 x 16 - 20 per pack
- **REGQ05** - M5 x 25 - 15 per pack
- **REGQ06** - M6 x 16 - 10 per pack
- **REGQ07** - M6 x 25 - 10 per pack
- **REGQ08** - M6 x 45 - 5 per pack

Slotted Screw

- **REGQ25** - M5 x 10MT - 20 per pack



S/Tap Pozi Steel Screw

- **REGQ15** - 6 x 3/8" - 30 per pack
- **REGQ17** - 8 x 3/8" - 30 per pack
- **REGQ31** - 6 x 1/4" - 30 per pack
- **REGQ32** - 8 x 1/2" - 30 per pack
- **REGQ33** - 8 x 3/4" - 30 per pack
- **REGQ34** - 8 x 12.5mm - 20 per pack



M8 x 35 Bolt Black Hex HT

5 Bolts per pack

REGQ28



Electrical Connectors









Push-In Electrical Connectors

Fast, easy and reliable

- A sophisticated push-in wire connector used for fast, easy and reliable connection and distribution of cable and conductors in electrical housing applications.
- They may be used within a typical range of housing voltage up to 450 volts.
- The double spring allows easy processing and will support installers especially in tricky situations, such as overhead work. This ensures proper fixing that can be checked visually through the transparent housings.
- Cross-sections from 0.5 up to 2.5 mm² can conveniently be housed.
- Colour coding provides a quick and easy identification of the different connectors.

Types available:

- **REGQ262:**  **2 Pole (4 per pack)**
- **REGQ263:**  **3 Pole (4 per pack)**
- **REGQ264:**  **4 Pole (3 per pack)**
- **REGQ265:**  **5 Pole (2 per pack)**
- **REGQ266:**  **6 Pole (2 per pack)**
- **REGQ268:**  **8 Pole (2 per pack)**

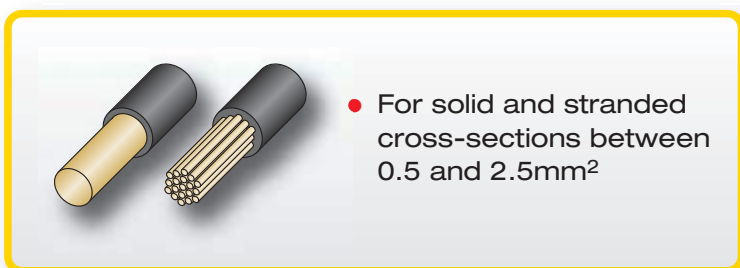

Blue Insulated Ring Connector

20 per pack

- For wires 1.5 - 2.5mm.
- High quality, pre-insulated crimp terminals.
- Flared entry for easy location of cable.
- Use with Ratchet Crimping Tool *REGB80* (p43).

REGQ200



Red Insulated Ring Connector

10 per pack

- For wires 0.5 - 1.5mm.
- High quality, pre-insulated crimp terminals.
- Flared entry for easy location of cable.
- Use with Ratchet Crimping Tool *REGB80* (p43).

REGQ201



Yellow Insulated Ring Connector

10 per pack

- For wires 4.0 - 6.0mm.
- High quality, pre-insulated crimp terminals.
- Flared entry for easy location of cable.
- Use with Ratchet Crimping Tool *REGB80* (p43).

REGQ202



Red Butt Connector

15 per pack

- For wires 0.5 - 1.5mm.
- High quality, pre-insulated crimp terminals.
- Flared entry for easy location of cable.
- Use with Ratchet Crimping Tool *REGB80* (p43).

REGQ204



Blue Butt Connector

15 per pack

- For wires 1.5 - 2.5mm.
- High quality, pre-insulated crimp terminals.
- Flared entry for easy location of cable.
- Use with Ratchet Crimping Tool *REGB80* (p43).

REGQ205



Red Ignition Lead Connector - Female

10 per pack

- For wires 0.5 - 1.5mm.
- High quality, pre-insulated crimp terminals.
- Flared entry for easy location of cable.
- Use with Ratchet Crimping Tool *REGB80* (p43).

REGQ220



Electrical Connectors



REGQ210

Red Push-On Connector - Male

15 per pack

- For wires 0.5 - 1.5mm.
- High quality, pre-insulated crimp terminals.
- Flared entry for easy location of cable.
- Use with Ratchet Crimping Tool *REGB80* (p43).



REGQ215

Red Push-On Connector - Female

10 per pack

- For wires 0.5 - 1.5mm.
- High quality, pre-insulated crimp terminals.
- Flared entry for easy location of cable.
- Use with Ratchet Crimping Tool *REGB80* (p43).



REGQ216

Red Bullet Connector - Male

10 per pack

- For wires 0.5 - 1.5mm.
- High quality, pre-insulated crimp terminals.
- Flared entry for easy location of cable.
- Use with Ratchet Crimping Tool *REGB80* (p43).



REGQ217

Red Bullet Connector - Female

10 per pack

- For wires 0.5 - 1.5mm.
- High quality, pre-insulated crimp terminals.
- Flared entry for easy location of cable.
- Use with Ratchet Crimping Tool *REGB80* (p43).



REGQ218

Blue Bullet Connector - Male

10 per pack

- For wires 1.5 - 2.5mm.
- High quality, pre-insulated crimp terminals.
- Flared entry for easy location of cable.
- Use with Ratchet Crimping Tool *REGB80* (p43).



REGQ219

Blue Bullet Connector - Female

10 per pack

- For wires 1.5 - 2.5mm.
- High quality, pre-insulated crimp terminals.
- Flared entry for easy location of cable.
- Use with Ratchet Crimping Tool *REGB80* (p43).

Blue Piggy Back Connector

10 per pack

- For wires 1.5 - 2.5mm.
- High quality, pre-insulated crimp terminals.
- Flared entry for easy location of cable.
- Use with Ratchet Crimping Tool *REGB80* (p43).

REGQ240



Red Piggy Back Connector

10 per pack

- For wires 0.5 - 1.5mm.
- High quality, pre-insulated crimp terminals.
- Flared entry for easy location of cable.
- Use with Ratchet Crimping Tool *REGB80* (p43).

REGQ241



Blue Quick-Fit Connector

6 per pack

- Simple to use.
- Excellent electrical connection without cutting the wires.

REGQ245



Connector Strip 5A PVC 12 Way

2 strips per pack

- Flexible polyethylene material with 12-way terminal strip and brass inserts and screws.
- 80°C working temperature.
- See p41 for Insulated Terminal Driver *REGE251*.

REGQ230



Connector Strip 15A PVC 12 Way

1 strip per pack

- Flexible polyethylene material with 12-way terminal strip and brass inserts and screws.
- 80°C working temperature.
- See p41 for Insulated Terminal Driver *REGE251*.

REGQ231



RSM Pack Screws/Connectors

Pack quantity as pictured

REGQ316



Tapes & Labels

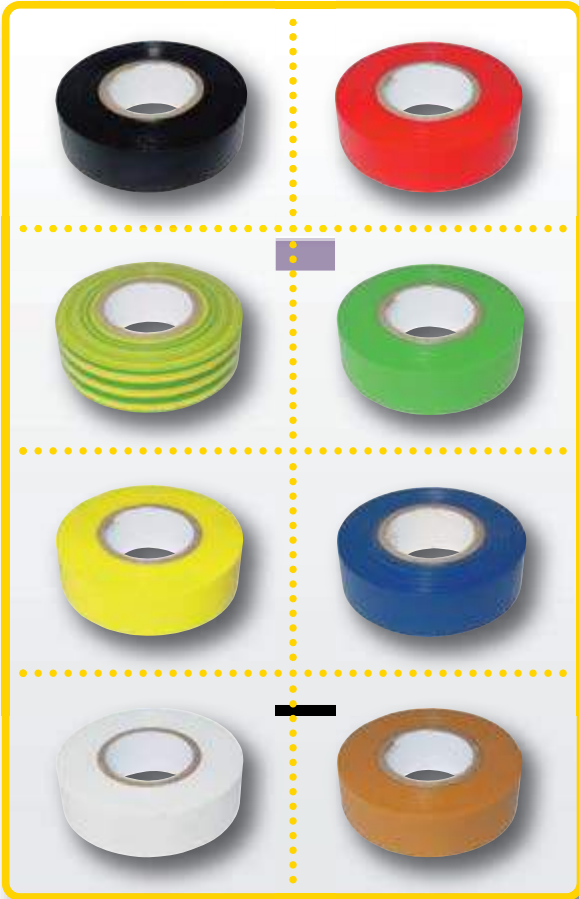

PVC Insulation Tape

Suitable for electrical insulation, binding, colour coding and general work.

- Conforms to BS3924.
- 19mm wide.
- 20m long.
- Flame retardant.

Colours available:

- **REGQ641:** Black
- **REGQ642:** Red
- **REGQ643:** Green/Yellow Stripe
- **REGQ644:** Green
- **REGQ645:** Yellow
- **REGQ646:** Blue
- **REGQ647:** White
- **REGQ648:** Brown



'GAS' Pipe Label

8 per pack

- Self adhesive.
- Easy-Peel-Off backing.



'HOT WATER' Pipe Label

8 per pack

- Self adhesive.
- Easy-Peel-Off backing.



'COLD WATER' Pipe Label

8 per pack

- Self adhesive.
- Easy-Peel-Off backing.

4mm Brass Olive

6 per pack

REGQ125



6mm Brass Olive

6 per pack

REGQ127

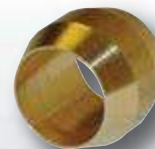

8mm Brass Olive

5 per pack

REGQ128



10mm Brass Olive

5 per pack

REGQ129



12mm Brass Olive

4 per pack

REGQ132



15mm Brass Olive

6 per pack

REGQ130



22mm Brass Olive

3 per pack

REGQ131



NEW

Regin

www.regin.co.uk



BRAND NEW website:
www.regin.co.uk

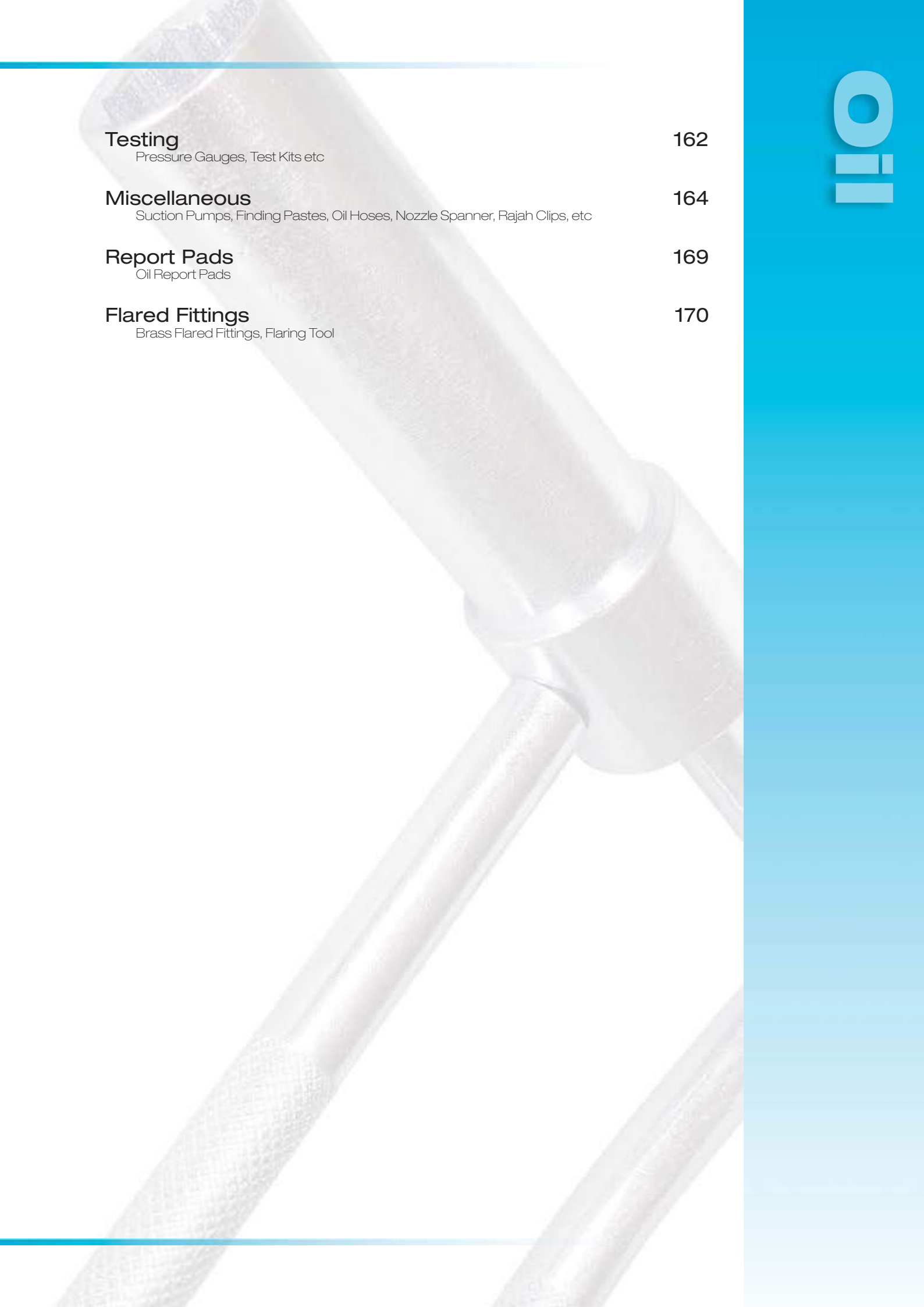

Testing

Pressure Gauges, Test Kits etc

162

Miscellaneous

Suction Pumps, Finding Pastes, Oil Hoses, Nozzle Spanner, Rajah Clips, etc

164

Report Pads

Oil Report Pads

169

Flared Fittings

Brass Flared Fittings, Flaring Tool

170

Testing

**REG060****Pressure Gauge
0-300psi**

0 - 300psi

- 1/8" bsp male - Bottom entry.

**REG065****Pressure Gauge
0-600psi**

0 - 600psi

- 1/8" bsp male - Bottom entry.

**REG066****Glycerol Filled Pressure Gauge
0-300psi**

0 - 300psi

- 1/8" bsp male - Bottom entry.
- Glycerol filled.

**REG067****Glycerol Filled Pressure Gauge
0-400psi**

0 - 400psi

- 1/8" bsp male - Bottom entry.
- Glycerol filled.

**REG068****Glycerol Filled Pressure Gauge
0-600psi**

0 - 600psi

- 1/8" bsp male - Bottom entry.
- Glycerol filled.

**REG069****Vacuum Gauge**

0 to -1000mbar

- 1/8" bsp male - Bottom entry.

Oil Pressure Test Kit

- Kit comprises:

Oil Pressure Test manifold (*REGO40*).

1/8" bsp female x 1/8" bsp female Flexible Hose (*REGO41*).

Pressure Gauge 0-300psi (*REGO60*).

- Supplied in a nylon zip bag.

REGO80



Oil Vacuum Test Kit

- Kit comprises:

Oil Pressure Test manifold (*REGO40*).

1/8" bsp female x 1/8" bsp female Flexible Hose (*REGO41*).

Vacuum Gauge 0 to -1000mbar (*REGO69*).

- Supplied in a nylon zip bag.

REGO81



Smoke Test Kit

- Kit comprises:

Smoke Test Pump with 200mm sampling probe.
Smoke comparison chart, maintenance oil & filter papers.

- Supplied in a protective nylon carry case.

REGX80



Oil Pressure Test Manifold

- Used in conjunction with a variety of pressure gauges.

REGO40



Flexible Hose

- 1/8" bsp female x 1/8" bsp female Flexible Hose.

REGO41



Miscellaneous

REG085



Oil Suction Pump

GOK Oil Suction Pump.

- For use on new or old heating systems which are not self priming.
- Especially useful during modifications or commissioning of oil supply system.
- Pumps on the 'push' & the 'pull' stroke to prime the system with oil easily & quickly.
- Unit has a suction hose for connecting to de-aerators.
- Braided hose 1/4" F BSPP x 1/4" F BSPP.
- Unit has a discharge flexible hose for draining excess oil into basin.
- Maximum suction -0.8 bar. Stroke volume 400ml.
- Steel construction barrel painted for corrosion resistance.

REG002



Kolor Kut Fuel Finding Paste

Fuel finding Paste

- 62g jar.
- Easily test for diesel, petrol, kerosene, crude oil & jet fuels.
- Pink paste turns bright red after contact with fuel, indicating the level in the tank.
- Paste is made entirely of non-hazardous materials and cleans off easily after use.

REG003



Kolor Kut Water Finding Paste

Water finding Paste

- Net wt. 3ozs (85g).
- For testing for the presence of water at the bottom of fuel storage tanks.
- Applied to a rod or length of string with bottom weight, the brown paste changes colour to brilliant red where it comes into contact with water giving you a visual indication as to the depth of the water present.

Vaporising Kit

- To enable Service & Commissioning Technicians to easily and conveniently level vaporising burner bases bi-directionally (reducing time and expense), and the accurate calibration of low and high fire cold flow rates. Also measures cold oil depths for most vaporising appliance burner types.
- Kit comprises:
Steel Levelling Plate, Bulls-eye Level, Steel Rule, Measuring Cylinders x 2 & Stopwatch and sturdy carry case.

REG090



Oil Burner Nozzle Case

- Suitable for oil burner nozzles.
- Storage for up to 40 nozzles with foam padding.
- Complete with carry handle.

REG095



Oil Burner Nozzle Spanner

- High Quality Oil Burner Nozzle Wrench for removing the nozzle from the Nozzle Adapter.
- Proven design for one handed ease of removal and installation.
- Chrome plated and rugged.
- Standard 5/8" x 3/4" double independent socket.

REG096



Miscellaneous

**REGO70****Aluminium Oil Filter**

1/4" bsp

- Complete with paper element.

**REGO71****Paper Element - 15 Micron**

- Replacement paper element for *REGO70* Aluminium Oil Filter.
- 15 Micron.

**REGO72****Stainless Steel Element - 60 Micron**

- Replacement stainless steel element for *REGO70* Aluminium Oil Filter.
- 60 Micron.

**REGO73****Stainless Steel Element - 100 Micron**

- Replacement stainless steel element for *REGO70* Aluminium Oil Filter.
- 100 Micron.

**Flexible Oil Hose**

1/4" bsp Male to 1/4" bsp Female

- **Sizes available:**

- **REGO45** - 500mm braided hose.
- **REGO50** - 700mm braided hose.
- **REGO55** - 1000mm braided hose.

Sootbreaker

- Enables oil and solid fuel fired boilers (and warm air heaters) to be cleaned whilst they are actually operating.
- Removes soot and other deposits from the combustion chamber and flue gas passages.
- Combats corrosion of heat transfer surfaces.
- One tube for boilers up to 100,000 Btu.
- If used on a regular basis Sootbreaker will ensure a clean, efficient boiler.

REGM05



Flue Rake

- The flue rake reaches the stubborn parts that brushes won't reach. It has a chisel at one end and a flat scraper at the other.

REGT57



Appliance Scrape Away Set

- Can be used on flat surfaces for carbon deposit removal such as steel or cast iron boiler chamber walls.

REGT59



Oil Boiler Flue Brush Set

Set of 3 brushes

- Set comprises:
25mm (1") x 500mm, 50mm (2") x 500mm
& 75mm (3") x 900mm round brushes.

REGT56



Miscellaneous

REGM08**Heldite Universal Sealant**

250ml with brush applicator

HELDITE is a high performance sealant for preventing leakage of Oils, Hydraulic Fluids, Water, Steam, Gases, Coolants and Fuels (excluding ethanol) in all branches of Automotive, Auto Mechanical, Electrical and General Engineering, Plumbing, Heating and Pipeline Services.

- Flexible and adhesive.
- Completely waterproof.
- Non-abrasive, anti-corrosive and inert.
- Temperature range: -40°C to +350°C.

Not compatible with Ethanol and potable water.

REG005**Rajah Clip**

- Unshrouded push on straight.

REG015**Rajah Clip**

- Semi-shrouded push on straight.

REG025**Rajah Clip**

- Fully shrouded straight.

REG030**Rajah Clip**

- Fully shrouded suppressed straight.

Oil Firing Installation Completion Report Pad

REGOCD10

50 reports in duplicate

- Record compliance with building, health, safety and efficiency regulatory requirements and manufacturers installation instructions.
- The report gives the information needed for inspecting and commissioning the installation.

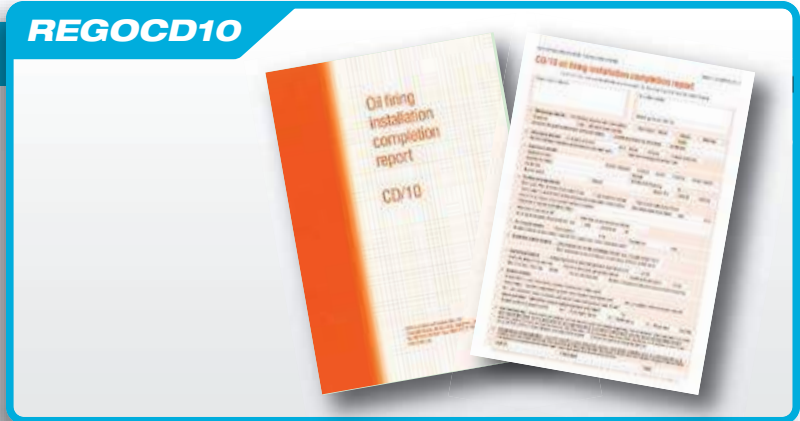

Oil Firing Service & Commissioning Report Pad

REGOCD11

50 reports in duplicate

- Provides written evidence of service/maintenance confirming the condition of the appliance and installation, any non-conformities and any remedial work required to bring the installation up to current regulations/standards.

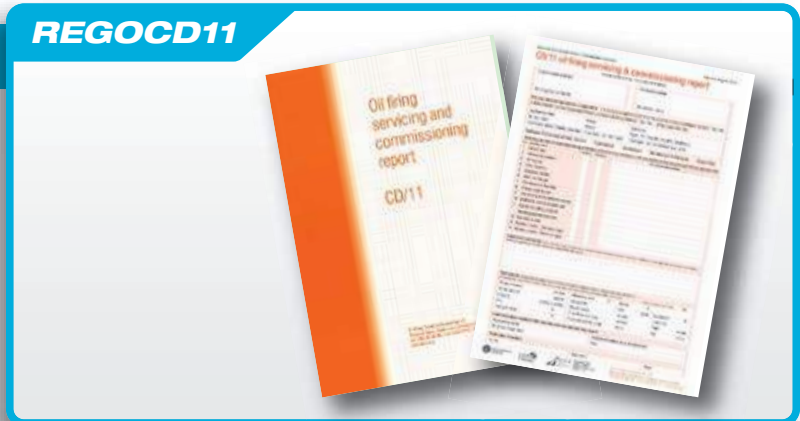

Oil Condensing Boiler Installation Report Pad

REGOCD30

50 reports in duplicate

- This form may be used to show that a Non-Condensing Boiler is reasonable provision for the purposes of complying with Part L of the Building Regulations in England, Wales, Scotland, Northern Ireland and the Republic of Ireland.

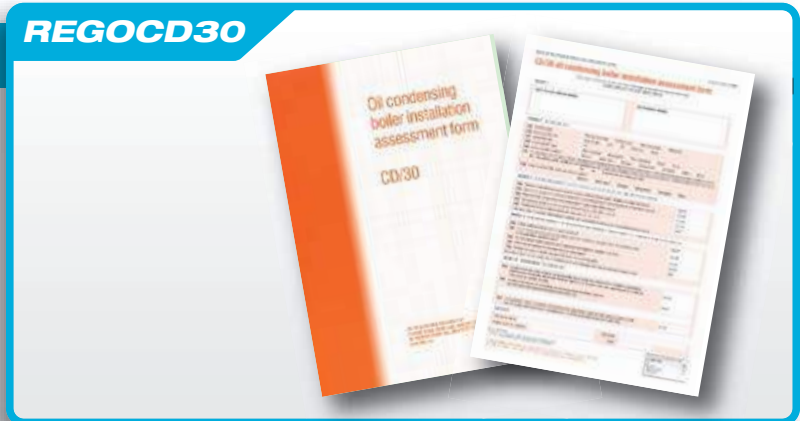

Oil Storage Risk Assessment Report Pad

REGOTI133

50 reports in duplicate

- Covers the risk of environmental damage from domestic oil storage tanks.

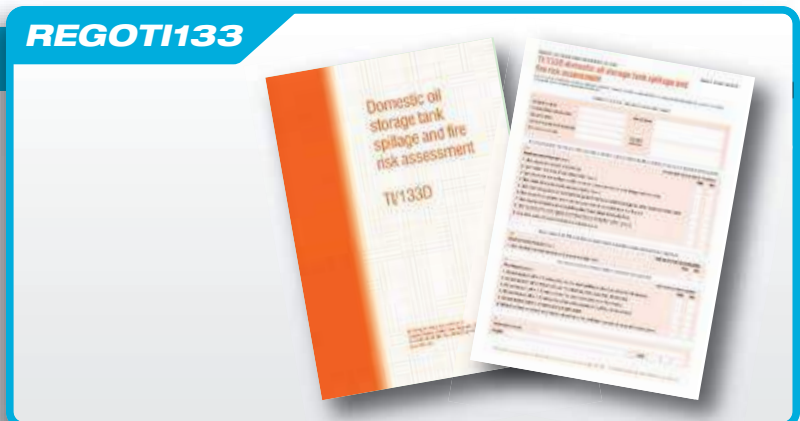

Flared Fittings

REGO100



Metric 45° Flaring Tool

For 4mm - 16mm diameter pipes.

- BS EN 1254-2:1998 defines two types of compression fittings for use with copper tubes to BS EN 1057: 1996. Type A consists of a nut and olive, Type B includes flared fittings. Type A are designed for use on hard copper (R290) or half hard (R250) copper where the union can be tightened onto the olive to form a seal onto the rigid pipe. If used on soft copper, Type A fittings can distort the pipe, causing weeping, sweating or leaks, which is unacceptable given environmental considerations. BS EN 1254-2: 1998 highlights concern over using type A fittings with R220 (annealed) soft copper pipe, stating that internal support of the tube can be required to allow compression of the ring onto the copper tube. BS EN 1254-2: 1998 states that Type B fittings should be used with R220 (annealed) soft copper tube.



One advantage of flared fittings is that metric pipe can easily be joined to imperial. A new appliance or pipework can be connected to an existing 3/8" supply by using a 10mm flared fitting with an optional 3/8" nut. Type A compression fittings would not necessarily give a sound installation, and in particular for oil suction lines, it is crucial not just to get an oil tight seal, but also an airtight one as well. It is vitally important for all installers to ensure they have created a fully compliant and sound installation - and that means the pipes and fittings as well.

- Supplied in protective carry case.

Regin
Premier

REGO104



Plastic/Copper Transition Fitting Kit

10mm Flare to Type A Fitting

- For use in the transition of underground plastic to copper pipe.
- Fitting has a flare on one end and a type A compression on the other.
- Kit includes: Transition fitting, 10mm Compression nut, 10mm Copper olive, Copper insert and 10mm Flare nut.

REGO125



Flared Fitting - Tee

- 15mm x 10mm x 10mm Tee (with nuts).

Flared Fitting - Elbow

- 10mm Elbow - Equal (two nuts).

REGO110



Flared Fitting - Elbow

- 10mm Elbow x 1/4" bspt (one nut).

REGO113

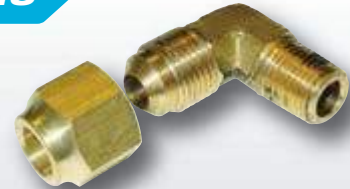

Flared Fitting - Union

- 10mm Union x 3/8" bspt (one nut).

REGO116



Flared Fitting - Union

- 10mm Union x 1/4" bspt (one nut).

REGO119

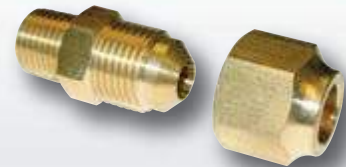

Flared Fitting - Union

- 10mm Equal Union (two nuts).

REGO122



Flared Fitting - Short Nut

- 3/8" bspt Short Nut (pack of 4).

REGO128



VT400**Val-U-Trade Leak Spray - 400ml**

400ml

- Safe detection of positive leaks.
- Suitable for use with most gases.
- Compatible with most metals and plastics.
- Fast and easy application.
- *Merchants Please Note: only available in box quantities: 12 cans per box.*

VT500**Val-U-Trade Air Duster - 500ml**

500ml

The perfect answer for quick and easy removal of dust and debris from inaccessible places.

- Quick & easy non-contact removal of dust & debris from:
Burner jets, boilers, radio & TV chassis, variable condensers, micro components, keyboards, camera lenses & shutters, PCB's etc.
- *Merchants Please Note: only available in box quantities: 12 cans per box.*

VT02**Val-U-Trade Blue Paper Towel - 2-Ply**

- Approx. 100 sheets per roll.
- 2 ply.
- Each sheet measures approx. 25cm x 40cm.
- *Merchants Please Note: only available in box quantities: 18 rolls per box.*

Val-U-Trade Landlords Pad

50 reports in triplicate

- Record safety checks carried out during a Landlord/Home Owner gas safety inspection.
- **Merchants Please Note:** only available in box quantities: 20 pads per box.

VT50

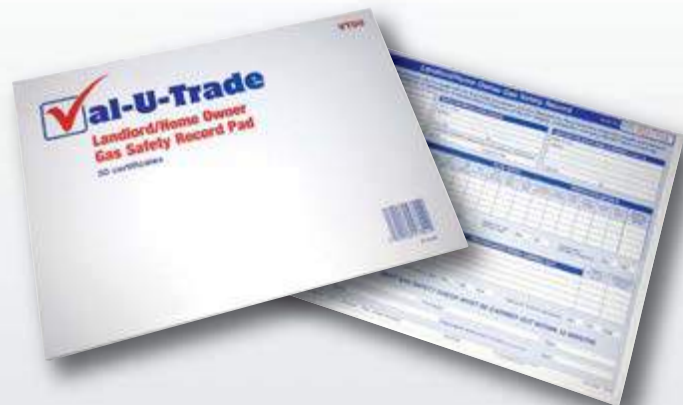

Val-U-Trade Cotton Twill Stair Runner

24' x 3' (732cm x 91cm)

- 100% Natural Cotton.
- For covering stairs or hallways.
- For general purpose protection.
- Reusable.
- **Merchants Please Note:** only available in bale quantities: 15 stair runners per bale.

VT33



Val-U-Trade Cotton Twill Dustsheet

12' x 9' (366cm x 274cm)

- 100% Natural Cotton.
- For covering all furniture & floors.
- For general purpose protection.
- Reusable.
- **Merchants Please Note:** only available in bale quantities: 10 dustsheets per bale.

VT36



DISPLAYSTAND_B&B



Bits'n'Bolts Counter Top Display Stand

Free of charge to Merchants

- Featuring 16 prongs to display products from our Bits 'n' Bolts range.
- Each prong can hang up to 40+ packs.
- Hi-quality powder coated construction.
- Hi-impact - ideal for impulse purchases.
- Dimensions of stand: approx. 410mm (w) x 230mm (d).
- Height approx. 770mm.

Please note: Products are not included.

NEW



For all the latest products from Regin visit our BRAND NEW website:

www.regin.co.uk



Wall Mounted Display Board

Free of charge to Merchants

- Create a striking arrangement and display your Regin products and boost your sales.
- Our extremely versatile, robust metal display board enables our stockists to create a display quickly, easily and effectively.
- Products can be arranged in a way to best suit any size and shape of products in order to maximise space.
- Supplied complete with medium duty round ended Euro hooks, which can be arranged in any configuration.
- Dimensions of board: approx. 610 x 915mm.

DISPLAYBOARD



Regin Brochure

Our 180+ page Brochure featuring our complete range of tools, consumables and much more.

- Please contact us if you require more copies for you sales counter.

CAT10



Regin Products Ltd reserves the right to alter design, material and product specifications of any product in the interests of progress and development without prior notice.

Details and descriptions are correct at time of print. Errors and omissions excepted.

Please Note: All measurements and quantities in this publication are approximate.

REGA05	76	REGB90	32	REGE272	39
REGA06	76			REGE273	39
REGA07	76			REGE274	39
REGA10	76	REGC10	52	REGE280	40
REGA15	76	REGC19	125	REGE285	40
REGA20	77	REGC20	125	REGE360	53
REGA25	77	REGC21	125	REGAAA4	122
REGA30	77	REGC22	125	REGAAA4	122
REGA35	77	REGC24	125	REGAAG3	122
REGA37	77	REGC25	125	REGAAG13	123
REGA38	77	REGC30	125	REGEC2	122
REGA40	78	REGC40	127	REGED2	122
REGA45	78	REGC50	125	REGEDLAA4	123
REGA46	78	REGC70	124	REGEDLAAA4	123
REGA50	78			REGEDLC2	123
REGA55	78			REGEDLD2	123
REGA60	78	REGD07	28	REGEDLNV1	123
		REGD10	28	REGENV1	122
		REGD12	29		
REGB01	34	REGD15	28		
REGB02	34	REGD25	29	REGEP20	94
REGB05	35	REGD32	29	REGEP21	94
REGB10	35			REGEP22	94
REGB15	35			REGEP23	94
REGB19	36	REGE10	55	REGEP24	94
REGB20	37	REGE11	54	REGEP25	94
REGB21	36	REGE12	54	REGEP26	95
REGB22	36	REGE13	54	REGEP27	95
REGB25	37	REGE15	55	REGEP28	95
REGB26	37	REGE20	48	REGEP29	95
REGB27	30	REGE30	48	REGEP30	95
REGB30	37	REGE40	48	REGEP31	95
REGB32	36	REGE45	48		
REGB33	36	REGE50	47		
REGB34	36	REGE103	124	REGH05	70
REGB35	37	REGE105	124	REGH150	112
REGB36	36	REGE210	42	REGH150L	112
REGB39	34	REGE211	42	REGH200	112
REGB44	34	REGE215	42	REGH230	112
REGB46	34	REGE216	42	REGH300	112
REGB49	33	REGE220	43	REGH300FR	112
REGB50	33	REGE225	41	REGH350	112
REGB51	31	REGE228	43	REGH450	112
REGB57	31	REGE235	39		
REGB70	35	REGE240	39		
REGB77	31	REGE251	41	REGJ01	81
REGB80	43	REGE252	41	REGJ55	79
REGB81	38,109	REGE255	39	REGJ56	79
REGB83	38,109	REGE265	39	REGJ57	79
REGB85	38,109	REGE271	39	REGJ58	79

REGJ59 - REGP65

REGJ59	79	REGM31	19	REGO81	163
REGJ60	79	REGM32	19,59	REGO85	164
REGJ64	80	REGM34	119	REGO90	165
REGJ65	81	REGM35	118	REGO95	165
REGJ70	81	REGM36	118	REGO96	165
REGJ71	81	REGM38	118	REGO100	170
REGJ72	81	REGM39	119	REGO104	170
REGJ75	80	REGM40	64	REGO110	171
		REGM41	64	REGO113	171
		REGM42	64	REGO116	171
REGK01	6,7	REGM44	82	REGO119	171
REGK02	6	REGM45	82	REGO122	171
REGK03	6	REGM46	82	REGO125	170
REGK05	99	REGM47	82	REGO128	171
REGK07	99	REGM48	82		
REGK10	16	REGM50	96	REGOCD10 ..	89,169
REGK15	100	REGM51	96	REGOCD11 ..	89,169
REGK17	100	REGM52	96	REGOCD30 ..	89,169
REGK20	100	REGM53	96	REGOTI133 ..	89,169
REGK21	102	REGM60	70		
REGK22	103	REGM62	32		
REGK25	100	REGM66	121	REGP01	93
REGK26	101	REGM70	101	REGP02	93
REGK28	9	REGM75	70	REGP05	92
REGK29	9	REGM76	70	REGP10	92
REGK30	8	REGM80	64	REGP11	93
REGK33	9			REGP15	91
REGK34	9	REGO02	164	REGP33	93,135
REGK35	8	REGO03	164	REGP34	92
REGK36	9	REGO05	168	REGP36	90
REGK40	35	REGO15	168	REGP39	92
REGK75	52	REGO25	168	REGP40	91
REGK90	30	REGO30	168	REGP41	92
		REGO40	163	REGP42	93
REGL01	106	REGO41	163	REGP43	91
REGL05	106	REGO45	166	REGP44	91
REGL10	106	REGO50	166		
REGL30	111	REGO55	166	REGP45	83
REGL40	111	REGO60	162	REGP46	83
REGL45	111	REGO65	162	REGP47	85
		REGO66	162	REGP50	84
		REGO67	162	REGP55	84
REGM05	167	REGO68	162	REGP56	85
REGM08	110,168	REGO69	162	REGP58	85
REGM20	110	REGO70	166	REGP62	86
REGM25	117	REGO71	166	REGP63	86
REGM26	117	REGO72	166	REGP64	86
REGM29	119	REGO73	166	REGP65	84
REGM30	19	REGO80	163		

REGP66	86	REGQ100	141	REGQ185	141
REGP70	88	REGQ101	141	REGQ186	141
REGP71	88	REGQ110	140	REGQ187	141
REGP80	25,88	REGQ111	140	REGQ188	141
REGP95	97	REGQ112	140	REGQ189	141
REGP96	97	REGQ115	140	REGQ190	140
REGP97	97	REGQ120	142	REGQ191	143
REGP98	97	REGQ121	142	REGQ192	143
REGP99	97	REGQ122	142	REGQ193	143
		REGQ123	142	REGQ194	143
		REGQ124	142	REGQ195	143
REGPC1	87	REGQ125	159	REGQ200	155
REGPC2	87	REGQ127	159	REGQ201	155
REGPC3	87	REGQ128	159	REGQ202	155
		REGQ129	159	REGQ204	155
		REGQ130	159	REGQ205	155
REGPE1	88	REGQ131	159	REGQ210	156
REGPE2	88	REGQ132	159	REGQ215	156
		REGQ136	146	REGQ216	156
		REGQ138	146	REGQ217	156
REGQ01	153	REGQ139	147	REGQ218	156
REGQ02	153	REGQ140	146	REGQ219	156
REGQ03	153	REGQ141	146	REGQ220	155
REGQ04	153	REGQ142	146	REGQ221	152
REGQ05	153	REGQ143	146	REGQ222	152
REGQ06	153	REGQ144	146	REGQ223	152
REGQ07	153	REGQ145	146	REGQ224	152
REGQ08	153	REGQ146	146	REGQ230	157
REGQ09	153	REGQ147	146	REGQ231	157
REGQ15	153	REGQ148	146	REGQ235	150
REGQ17	153	REGQ149	146	REGQ236	150
REGQ25	153	REGQ150	146	REGQ237	150
REGQ28	153	REGQ151	146	REGQ238	151
REGQ31	153	REGQ152	146	REGQ240	157
REGQ32	153	REGQ153	146	REGQ241	157
REGQ33	153	REGQ154	146	REGQ245	157
REGQ34	153	REGQ155	146	REGQ262	154
REGQ50	145	REGQ156	146	REGQ263	154
REGQ51	145	REGQ157	146	REGQ264	154
REGQ70	145	REGQ158	146	REGQ265	154
REGQ71	145	REGQ159	146	REGQ266	154
REGQ75	145	REGQ160	147	REGQ268	154
REGQ80	144	REGQ170	147	REGQ300	145
REGQ81	144	REGQ175	141	REGQ302	145
REGQ82	144	REGQ176	141	REGQ304	145
REGQ83	144	REGQ177	141	REGQ306	145
REGQ84	144	REGQ178	141	REGQ308	145
REGQ86	144	REGQ179	141	REGQ310	145
REGQ90	141	REGQ180	147	REGQ312	145
REGQ91	141	REGQ181	147	REGQ314	145

REGQ316 - REGT16

REGQ316	157	REGQ722	138	REGR18	126
REGQ600	148	REGQ723	138	REGR19	126
REGQ601	148	REGQ724	138	REGR30	127
REGQ602	151	REGQ725	138	REGR50	18
REGQ605	150	REGQ726	138	REGR51	18
REGQ608	151	REGQ727	138		
REGQ609	151	REGQ728	138	REGS05	75
REGQ610	149	REGQ729	138	REGS06	75
REGQ611	149	REGQ730	138	REGS07	75
REGQ615	149	REGQ751	139	REGS10	74
REGQ616	149	REGQ752	139	REGS15	72
REGQ619	149	REGQ753	139	REGS20	72
REGQ620	149	REGQ754	139	REGS21	74
REGQ621	148	REGQ755	139	REGS25	73
REGQ625	151	REGQ756	139	REGS30	73
REGQ630	158	REGQ757	139	REGS40	70
REGQ632	158	REGQ758	139	REGS50	74
REGQ634	158	REGQ759	139		
REGQ641	80,158	REGQ760	139	REGST01	133
REGQ642	80,158	REGQ761	139	REGST02	135
REGQ643	80,158	REGQ762	139	REGST03	135
REGQ644	80,158	REGQ763	139	REGST10	132
REGQ645	80,158	REGQ764	139	REGST15	132
REGQ646	80,158	REGQ765	139	REGST20	132
REGQ647	80,158	REGQ766	139	REGST25	134
REGQ648	80,158	REGQ767	139	REGST30	134
REGQ660	150	REGQ768	139	REGST32	134
REGQ671	127,150	REGQ769	139	REGST34	134
REGQ680	151	REGQ770	139	REGST36	134
REGQ701	138	REGQ771	139	REGST40	134
REGQ702	138	REGQ772	139	REGST42	134
REGQ703	138	REGQ773	139	REGST44	134
REGQ704	138	REGQ774	139	REGST50	132
REGQ705	138	REGQ775	139	REGST65	114,131
REGQ706	138	REGQ776	139	REGST75	57,131
REGQ707	138	REGQ777	139	REGST80	131
REGQ708	138	REGQ778	139	REGST85	130
REGQ709	138	REGQ779	139	REGST86	130
REGQ710	138	REGQ780	139	REGST87	130
REGQ711	138	REGQ820	147		
REGQ712	138	REGQ825	147	REGT04	33
REGQ713	138	REGQ835	147	REGT08	47
REGQ714	138			REGT10	47
REGQ715	138	REGR01	18	REGT11	50,148
REGQ716	138	REGR05	17	REGT12	101
REGQ717	138	REGR09	17	REGT15	46
REGQ718	138	REGR10	18	REGT16	46
REGQ719	138	REGR11	126		
REGQ720	138	REGR12	126		
REGQ721	138				

REGT17	41	REGU42	10,128	REGX38	26
REGT18	46	REGU45	12	REGX39	26
REGT19	52	REGU50	13	REGX75	26
REGT20	49	REGU55	13	REGX80	163
REGT21	51	REGU60	13	REGX90	51
REGT24	101	REGU65	13		
REGT25	50	REGU68	13		
REGT30	49	REGU69	13	REGXA1	24
REGT31	49	REGU70	11	REGXA3	25
REGT35	50	REGU75	16	REGXA5	25,127
REGT40	50	REGU77	14	REGXA6	25
REGT50	32	REGU78	14	REGXA7	25
REGT51	62	REGU80	14	REGXA8	23
REGT55	62	REGU83	16	REGXA55	23
REGT56	62,167			REGXA56	23
REGT57	167			REGXA455	22
REGT59	167	REGV10	59		
REGT75	63	REGV11	59	REGXE09	45
REGT76	63	REGV15	57	REGXE15	45
REGT77	63	REGV20	58	REGXE31	20
REGT79	62	REGV25	58	REGXE40	44
REGT80	63	REGV30	58	REGXE45	44
REGT81	60	REGV35	58	REGXE65	57
REGT82	60	REGV40	58	REGXE68	56
REGT83	60	REGV45	58	REGXE70	56
REGT84	60			REGXE77	56
REGT85	63				
REGT86	61	REGW10	121		
REGT87	61	REGW20	116	REGXP1	66
REGT88	61	REGW21	116	REGXP2	66
REGT89	61	REGW23	116	REGXP3	67
		REGW26	116	REGXP5	67
		REGW28	121	REGXP7	68
REGU01	15	REGW31	121	REGXP8	68
REGU03	15	REGW40	114	REGXP9	68
REGU04	15	REGW41	115	REGXP25	69
REGU05	11	REGW42	115	REGXP26	69
REGU10	12	REGW43	115	REGXP27	69
REGU15	12	REGW44	115	REGXP100	65
REGU20	12	REGW45	114	REGXP102	128
REGU25	11	REGW46	114	REGXP125	69
REGU30	11	REGW50	120		
REGU31	11	REGW70	121		
REGU32	11	REGW80	120		
REGU35	10	REGW90	120	REGY01	98
REGU36	10,128			REGY05	98
REGU38	10,128			REGY10	98
REGU39	10,128	REGX01	27	REGY12	98
REGU40	10	REGX10	8	REGY15	113
REGU41	10,128	REGX32	21	REGY16	113

REGY20 - VT500

REGY20	113
REGY21	113
REGY23	113
REGY25	113
REGY30	113

REGZ01	104
REGZ05	105
REGZ07	104
REGZ09	104
REGZ10	105
REGZ15	107
REGZ20	107
REGZ22	110
REGZ25	107
REGZ31	108,133
REGZ32	108,133
REGZ34	109
REGZ35	108
REGZ36	108
REGZ37	108
REGZ40	107
REGZ41	107
REGZ65	105,133
REGZ66	105,133

VT02	172
VT33	173
VT36	173
VT50	173
VT400	172
VT500	172

3 & 5 WAY CONNECTOR	124	BASIN WRENCH - SPRING LOADED	37
3 IN 1 THERMOMETER	56	BATTERIES	122-123
4 WAY UTILITIES KEY	36	BENDER - MINI TUBE	35
7 PIECE FLUE BRUSH SET	62	BIMETAL CONTACT THERMOMETER	57
7YR CO ALARM	28-29	'BITS'N'BOLTS'	137-159
10YR CO ALARM	28	'BITS'N'BOLTS' RETRIEVER	50,148
31 PIECE SOCKET SET	30	BLACK STOVE PAINT	132
360 INSPECTION LAMP	53	BLEEDER SET - RADIATOR	126
1000MM STOP COCK KEY	36	BLUE PAPER TOWEL	120
1000V CABLE SHEARS	41	BOILER CASE CLEANER	104
1000V COMBINATION PLIERS	42	BOILER CASE SEAL	79
1000V DIAGONAL CUTTING PLIERS	42	BOILER FIRST-AID KIT	99
1000V LONG NOSE PLIERS	43	BOROSCOPE - REGIN EYE	51
1000V VDE SCREWDRIVER	39	BRAIDED YARN	113
1000V VDE SCREWDRIVER 8 PIECE SET	40	BRASS OLIVES	159
1500°C FLUE & FIRE SEAL	108,133	BRASS TEST NIPPLES	147
		BRASS PRESSURE TEST TEE	16
AAV REMOVAL TOOL	49	BRUSH - FLUE SET	62
ABRASIVE MINI PADS	64	BRUSH - HEAT EXCHANGER	60
ABRASIVE SILICONE CARBIDE STRIPS	64	BRUSH - NYLON	60-61
AC VOLTAGE DETECTOR	45	BRUSH - SOFT BRISTLE	63
ADAPTOR - GAS TEST NIPPLE	15	BRUSH - STEEL WIRE MINI	149
ADAPTOR PLATE - METER	127	BRUSH - WIRE	63
ADAPTOR - SOCKET INTERFACE	68	BULLET CONNECTOR	156
ADHESIVE - GLASS YARN	113	BUNGEE STRAPS	70
ADHESIVE - MULTI-PURPOSE SPRAY ON	105	BUTT CONNECTOR	155
ADJUSTABLE WRENCH	31	BUTTON BATTERIES	122-123
AIR DUSTER AEROSOL	104-105		
ALARM - CO	28-29	CABLE CLIPS	151
ALARM - SMOKE	28-29	CABLE FASTENERS	150
ALUMINIUM FOIL TAPE	81	CABLE SHEARS - 1000V	41
ANALYSER - ONE-CLICK	24	CABLE TIES	149
ANALYSER - PREMIER ULTI-MATE	22	CALICO COTTON DUST SHEET	118
ANALYSER APPLIANCE SAMPLING PROBE KIT	23	CARAVAN/BOAT GAS INSPECTION RECORD PAD	85
ANALYSER PRINTER	23	CARBON MONOXIDE DETECTOR - MOBILE CO	27
ANALYSER PROBE HOLE COVERS	147	CARBON MONOXIDE ALARM	28-29
ANALYSER READINGS RECORD PAD	25	CASE CLEANER - BOILER	104
ANALYSER REPLACEMENT FILTER	25,127	CASE - OIL BURNER NOZZLE	165
ANALYSER TEST POINT PLUG	26	CASE SEAL - BOILER	79
ANGLED ADAPTOR	9	CATERING PAD	85
ANGLED SCREWDRIVER	148	CENTRAL HEATING CLEANER	111
ANTI-SLIP CLEAN SOLES OVERSHOES	121	CENTRAL HEATING INHIBITOR	111
ANTI-STATIC WRIST STRAP	151	CENTRAL HEATING INSP/COMMISSIONING REPORT	86
ANTI-SURGE FUSES	146	CERAMIC FUSES	146
APPLIANCE SAMPLING PROBE KIT	23	CHAIN - COOKER	127
APPLIANCE SCRAPE AWAY SET	167	CHIMNEY & FLUE CLEANER	132
AUTOCUT® PIPE CUTTER	34	CHIMNEY/FLUE NOTICE PACK	88
AUTOMATIC PIPE CUTTER	34	CHIMNEY/HEARTH NOTICE PLATE	93,135
AUTOMATIC PIPE CUTTER HOLDER	34	CIRCUIT BREAKER	47
AUTOMATIC WIRE STRIPPER	43	CIRCULATION PUMP WASHERS	140
AUTO-RANGING MULTIMETER	44	CLAMP PROBES - CROCODILE TYPE	58
		'CLEAN-HANDS' DISPOSABLE GLOVES	116
'BACK TO BLACK' COAL PAINT	105,133	CLEANER - CENTRAL HEATING	111
BASIN WRENCH - CROWFOOT	37	CLEANER - STOVE GLASS	132
		CLEANING BLADES - HEAT EXCHANGER	63
		CLEANING STRIPS - CARBIDE	64
		CLEAN-SOLES OVERSHOES	121

CO ALARM	28-29
COAL PAINT	105,133
COLOURED STUMPY SPANNER SET	31
COMBINATION PLIERS - 1000V	42
COMBINATION STOP COCK KEY	36
COMBUSTIBLE GAS LEAK DETECTOR	26
COMBUSTION DEPOSIT REMOVER	167
COMMERCIAL REPORT PADS	87
COMPACT CONDENSATE PUMP	124
COMPONENT EXCHANGE LOOP TESTER	67
COMPOUND - HEAT SINK	107
COMPOUND - JOINTING	110
COMPRESSION FITTING	147
CONDENSATE PUMP	124
CONDENSING BOILER INST.ASSESSMENT FORM	86
CONNECTORS - ELECTRICAL	124,154
CONNECTOR STRIPS - ELECTRICAL	157
CONSUMABLES	71-128
CONTACT THERMOMETER	57
CONTINUITY BOND	52
CONTINUITY & INSULATION TESTER	66
CONTINUITY/VOLTAGE INDICATOR	45
CONTOUR TURNER	70
CONTRACT 30 12" 'U' GAUGE	11
CONTRACT 60 24" 'U' GAUGE	11
COOKER CHAIN	127
COOLSKIN HEAT RESISTANT GLOVES	116
COTTER PIN	150
COTTON TWILL DUST SHEET	119
CREOSOTE & TAR CLEANER	132
CRIMPING TOOL - RATCHET TYPE	43
CROCODILE TYPE CLAMP PROBES	58
CROWFOOT BASIN WRENCH	37
CUTTAKEEP AUTOMATIC PIPE CUTTER HOLDER	34
CUTTAKEEP KIT	34
CUTTING PLIERS - DIAGONAL - 1000V	42
DANGER - DO NOT USE STICKER	90
DIAGONAL CUTTING PLIERS - 1000V	42
DIAPHRAGM KIT	125
DIFFERENTIAL THERMOMETER	58
DIGIMAN DIFF ELECTRONIC MANOMETER	20
DIGITAL LOOP TESTER	66
DIGITAL RCD TESTER	67
DIGITAL MANOMETER	20-21
DIGITAL MULTIMETER	44,48
DIGITAL THERMOMETERS	56-59
DIGITAL PRESSURE VESSEL CHECKER	8
DIGITAL WOOD MOISTURE METER	131
'DIGITEMP' THERMOMETER KIT	59
DISPLAYBOARD/STAND	174-175
DISPOSABLE GLOVES	116
DIVERTOR VALVE DIAPHRAGM KIT	125
DO NOT OPERATE PLATES	97
DO NOT USE STICKER	90
DOUBLE SIDED FOAM TAPE	79
DRAIN-DOWN HOSE KIT	17
DRAINAGE PAD - RADTRAP	18
DRAINEASY RADIATOR DRAINING KIT	18
DRAINING KIT - DRAINEASY	18
'DROP-OUT' TESTER	49
DRY PIPE PRESSURE TEST CERTIFICATE	88
DRY PIPE PRESSURE TEST KIT	16
DUCT TAPE	80
DUO VOLTAGE SENSOR	46
DURACELL BATTERIES	123
DUST MASK	121
DUST SHEETS	118-119
EARTHING CLAMP	150
EASY REACH PROBE HANDLE	25
ECONOMY U GAUGE	11
ELECTRICAL CONNECTOR STRIPS	157
ELECTRICAL CONNECTORS	124
ELECTRICAL CONNECTORS - PUSH-IN	154
ELECTRICAL INSTALLATION CERTIFICATE	88
ELECTRICAL KIT	100
ELECTRICAL REPORT PADS	88
ELECTRICAL SCREWDRIVER - MULTI-TEST	41
ELECTRICAL STICKERS & TAGS	94-95
ELECTRONIC MANOMETER	20
ENGINEER KITS	100-101
EPOXY PUTTY	107
EXTRA LONG SCREWDRIVER SET	31
FAN ASSEMBLY OILER	110
FAN - HEAT POWERED	130
FAN PULLER - MULTI-SIZE	50
FIBRE WASHERS	140
FILLING KIT	111
FILTER - ANALYSER	25
FILTER - OIL	166
FIRE BLANKET	82
FIRE EXTINGUISHER - POWDER	82
FIRE RATED INSPECTION HATCH	112
FIRESTOP INTUMESCENT SEALANT	109
FIRST-AID KIT	82
FIRST-AID KIT - BOILER	99
FIXINGS - BOILER	99
FLARED FITTINGS	170-171
FLARING TOOL	170
FLEXIBLE OIL HOSE	166
FLEXIBLE WIRE PROBE	58
FLOW CUP	19
FLUE BRUSH - 7 PIECE	62
FLUE BRUSH SET	62
FLUE BRUSH SET - OIL	62,167
FLUE & CHIMNEY CLEANER	132
FLUE/FIREPLACE COMMISSIONING CERTIFICATE	86
FLUE HOLE COVERS	147
FLUE'N'FIRE 1500°C SILICATE CEMENT	108,133

- FLUE RAKE 167
 FLUX BRUSH 149
 FOAM TAPE 79
 FOIL TAPE - ALUMINIUM 81
 FREE-AIRGAUGE KIT 52
 FUEL FINDING PASTE 164
 FUMAX SMOKE PELLETS 72-74
 FUSE KIT 99-100
 FUSED MULTIMETER PROBES 48
 FUSES 146
- GAS COCK GREASE 107
 GAS INSTALLATION SAFETY REPORT - COMMERCIAL 87
 GAS LEAK DETECTION AEROSOL 106
 GAS LEAK DETECTOR - SNIFFA PLUS 26
 GAS SAFETY INSPECTION PAD 84
 GAS SPEC. PTFE TAPE 81
 'GAS' TAPE 76
 GAS TEST NIPPLE ADAPTOR 15
 GAS TESTING & PURGING REPORT - COMMERCIAL . 87
 GAS TESTING & PURGING REPORT - DOMESTIC . . . 86
 GAS & WATER JOINTING COMPOUND 110
 GAUGES - PRESSURE 162
 GIANT AEROSOL CANS 104
 GLASS CLEANER - STOVE 132
 GLASS FUSES 146
 GLASS YARN 113
 GLASS YARN ADHESIVE 113
 GLOVES - DISPOSABLE 116
 GLOVES - HEAT RESISTANT 116
 GLOVES - WORK GLOVES 114-115
 GLYCOL FILLED GAUGE 162
 GOGGLES 121
 GRATE & STOVE POLISH 133
 GREASE - SILICONE 107
- HAND PUMP 8
 HAND WIPES 120
 HANDLE PROBE 25
 HATCHES - INSPECTION 112
 HEADLIGHT - LED 55
 HEAT EXCHANGER CLEANING BLADES 63
 HEAT POWERED STOVE FAN 130
 HEAT RESISTANT GLOVES 116,131
 HEAT SINK COMPOUND 107
 HEAVY DUTY KNIFE BLADES 148
 HELDITE UNIVERSAL SEALANT 110,168
 HEX KEY - T HANDLE 36
 HEX KEY SET - IMPERIAL 36
 HEX KEY SET - METRIC 36
 HIGH TEMPERATURE SILICONE SEALANT 108
 HOOK AND PICK SET 35
- ID CARD HOLDER 121
 IDENTIFICATION TAPES 76-78
 IGNITION LEADS 125
 ILLUMINATED 'BITS'N'BOLTS' RETRIEVER 50,148
 IMMERSION SPANNERS 37
 IMPERIAL HEX KEY SET 36
 IMPERIAL O-RING KIT 102
 INFLATOR - VESSEL JET 6-7
 INFRA-RED THERMOMETER 57
 INHIBITOR - CENTRAL HEATING 111
 INSPECTION HATCHES 112
 INSPECTION LAMP - 360 53
 INSPECTION MIRRORS 50
 INSTALLERS SERVICE KIT 101
 INSULATED TERMINAL DRIVER 41
 INSULATION & CONTINUITY TESTER 66
 INSULATION STRIPPER PLIERS 35
 INSULATION TAPE 80,158
 INSULATION TEST LEAD SET - RED/BLACK 68
 INTERCHANGEABLE SCREWDRIVER SET 40
 INTERFACE ADAPTOR - SOCKET 68
 INTUMESCENT SEALANT - FIRESTORM 109
- 'J' GAUGE MANOMETER 11
 'J' GAUGE FLUID 11
 JOINTING COMPOUND 110
 JUBILEE HOSE CLIP 147
 JUNIOR HACKSAW BLADES 151
- K-TYPE THERMOMETER KIT 56
 KING SIZE SMOKE PELLETS 73
 KNEELING MAT 121
 KNIFE - RETRACTABLE 32
 KNIFE BLADES 148
 KOLOR KUT FUEL FINDING PASTE 164
 KOLOR KUT WATER FINDING PASTE 164
- LABELS - PIPE 158
 LAMINATED DUST SHEET 119
 LAMP - INSPECTION 53
 LANDLORD'S SAFETY RECORD PADS 83
 LANYARD 121
 LATEX GLOVES 116
 LEADS - IGNITION 125
 LEAK DETECTION - AEROSOLS 106
 LEAK DETECTION - ATOMISER 106
 LEAK DETECTION - BRUSH ON FLUID 106
 LEAK DETECTOR - ELECTRONIC 26
 LED HEADLIGHT 55

L - P

LED PENLIGHT	54	MULTI-PURPOSE ADHESIVE	105
LED TORCH	55	MULTI-PURPOSE SILICONE TEMP. REPAIR TAPE. . .	81
LED WORK LIGHT	54	MULTI-SIZE FAN PULLER	50
LOCATION PLATE.	97	MULTI TAP ADAPTOR.	18
LONG NOSE PLIERS - 1000V	43	MULTI-TEST ELECTRICAL SCREWDRIVER.	41
LONG RADIATOR BRUSH	62	MULTI-THERMOMETER	56
LONG SCREWDRIVER SET	31	MULTI-TOOL	33
LOOP TESTER - PART P.	66-67		
LPG PRESSURE RELIEF KIT	14		
MAG TIP MAGNETIC SCREW HOLDER	32	NEON MAINS TEST SCREWDRIVER	148
MAGNET TESTER	47	NEOPRENE TUBE	13
MAGNETIC 'BITS'N'BOLTS' RETRIEVER	50,148	NIPPLE - PRESSURE TEST.	147
MAGNETIC PARTS DISH 'MAG DISH'	70	NIPPLE ADAPTOR	15
MAGNETIC SCREW HOLDER	32	NITRILE GLOVES	116
MAGTESTER PLUS	47	NOTICE PLATES	97
MAINS WATER PRESSURE TEST KIT.	18	NOZZLE CASE	165
MAINTENANCE/SERVICE CHECK LIST PAD	84	NOZZLE SPANNER	165
MANIFOLD - OIL.	163	NOZZLES - SEALANT	151
MANOMETER - ELECTRONIC	20-21	NUTS - BRASS	145
MANOMETER FLUID	11-12	NUTS - SPIRE	144
MANOMETER - PREMIER	10	NUTS - SPLIT	145
MANOMETER RIGID TUBE	15	NUTS - STEEL	145
MANOMETERS	10-12,20-21		
MANOMETER TUBE.	13		
MARKER PENS	96	O-RING KITS	102-103
MAT - PLUMBERS WORK.	117	O-RINGS	138-139
MAT - SERVICE.	118	OIL BURNER NOZZLE CASE.	165
MATCHES - SMOKE.	75	OIL BURNER NOZZLE SPANNER	165
MATS - SOLDER.	98	OIL FILTER	166
MECHANICAL KIT.	100	OIL FIRING INSTALLATION COMPLETION REPORT. .	89
METER ADAPTOR PLATE - UNIVERSAL	127	OIL FLUE BRUSH SET	167
METER ADAPTOR WASHERS	141	OIL HOSE - FLEXIBLE	163
METER BOX KEY	149	OIL PRESSURE TEST KIT	163
METER SEALING DISC	147	OIL PRESSURE TEST MANIFOLD	163
METER UNION WASHERS	141	OIL REPORT PADS	89,169
METRIC HEX KEY SET	36	OIL STORAGE RISK ASSESSMENT REPORT. . .	89,169
METRIC O-RING KIT	103	OIL SUCTION PUMP	164
MICRO RATCHET WRENCH	30	OIL VACUUM TEST KIT	163
MINI PIPE CUTTER	35	OILER - ZOOM SPOUT.	110
MINI TUBE BENDER	35	OLIVE & WASHER KIT	100
MINI TUBE CUTTER.	35	OLIVES - BRASS	159
MINI WIRE BRUSH	149	ONE-CLICK RATIO ANALYSER	24
MINOR ELECTRICAL INST. WORKS CERTIFICATE. .	88	ONE-CLICK TEST LEAD SET	68
MIRRORS - INSPECTION	50	ONE WRAP GAS SPEC PTFE TAPE	81
MOBILE CATERING PAD	85	ORGANISER CASE.	101
MOBILE CO CARBON MONOXIDE DETECTOR.	27	OVERSHOES - CLEANSOLES.	121
MOISTURE METER - WOOD	131		
MOLYCOTE GAS COCK GREASE	107		
MONOBLOC SPANNER SET	37		
MRT - MANOMETER RIGID TUBE.	15		
MULTIFUNCTION DIGITAL LOOP TESTER	66	PADS - RECORD	83-87
MULTIFUNCTION DIGITAL RCD TESTER	67	PAINT MARKER PENS	96
MULTIMETER	44,48	PAINT - STOVE	132
MULTIMETER - AUTORANGING	44	PANASONIC BATTERIES	122
MULTIMETER PROBES & CLIPS.	48	PAPER ELEMENT - OIL FILTER.	166
MULTIMETER WITH TEMPERATURE	44	PAPER TOWEL	120

PART P DIGITAL INSULATION & CONTINUITY TESTER . . .	66	PUMP - COMPACT CONDENSATE	124
PART P KIT	65	PUMP PLIERS - WATER PUMP	33
PART P MULTIFUNCTION DIGITAL LOOP TESTER . . .	66	PUMP - PRESSURE VESSEL	8
PART P MULTIFUNCTION DIGITAL RCD TESTER . . .	67	PUMP - SUCTION	164
PAT ADAPTOR	69	PUMP WASHERS	140
PAT TESTING STICKERS	69	PUSH-IN ELECTRICAL CONNECTORS	154
PCB SUPPORT POSTS	152	PUTTY - EPOXY	107
PELLETS - SMOKE	72-74	PVC INSULATION TAPE	158
PENLIGHT - LED	54		
PEN TYPE PRESSURE GAUGE	9	QUICK BLOW FUSES	146
PICK AND HOOK SET	35		
PIGGY BACK CONNECTORS	157	RADIATOR BLEED KEY	126,149
PIPE CUTTER HOLDER	34	RADIATOR BLEEDER SET	126
PIPE CUTTERS	35	RADIATOR BRUSH	62
PIPE LABELS	158	RADIATOR CLAMP KIT	150
PIPE THERMOMETER	57	RADIATOR DRAINING KIT	18
PIPE THERMOMETER - STOVE	131	RADIATOR KEY	37
PLIERS - COMBINATION	42	RADTRAP - FLUID DRAINAGE PAD	18
PLIERS - DIAGONAL CUTTING	42	RADVALVE CHANGE KIT	17
PLIERS - LONG NOSE	43	RADVALVE TOPS TAMPER PROOF	126
PLIERS - PUMP	33	RAJAH CLIPS	168
PLUMBERS ELECTRICAL KIT	100	RAKE - FLUE	167
PLUMBERS MECHANICAL KIT	100	RATCHET CRIMPING TOOL	43
PLUMBERS WASHER KIT	100	RATCHET WRENCH	30
PLUMBERS WORKMAT	117	RATIO ANALYSER	24
PLUME KIT - SMOKE MATCH	74	RCD CIRCUIT BREAKER	47
PLUMBPAD	120	RCD TESTER - PART P	67
POCKET INFRA-RED THERMOMETER	57	RED/BLACK INSULATION TEST LEAD SET	68
POCKET ROCKET	70	RED SMOKE PELLETS	74
POINT OF SALE	174-175	REGIN EYE VIDEO BORESCOPE	51
POLISH - STOVE & GRATE	133	REMOVAL TOOL - AAV	49
PREMIER SOLDER MAT	98	REPAIR TAPE - SILICONE	81
PREMIER STUMPY ADJUSTABLE WRENCH	31	REPORT PADS	83-87
PREMIER 'U' GAUGE	10	RETRACTABLE TRIMMING KNIFE	32
PREMIER 'U' GAUGE BAG	10,128	RING CONNECTOR	155
PREMIER 'U' GAUGE FLUID	11	RSM PACK	157
PREMIER 'U' GAUGE SCREW & 'O' RING	10,128	RUBBER TUBE	13
PREMIER 'U' GAUGE STOPPER	10,128		
PREMIER ULTI-MATE ANALYSER	22	SAFETY TEST PLUG	48
PRESSURE GAUGE - PEN TYPE	9	SAFETY WARNING STICKER/TAG	90
PRESSURE GAUGES	162	SAMPLING PROBE KIT - ANALYSER	23
PRESSURE RELIEF KIT	14	SAW - SWIVEL	32
PRESSURE TEST KIT	14	SCHRADER VALVE CORE SCREWDRIVER	9
PRESSURE TEST KIT - DRY PIPE	16	SCHRADER VALVE CORES	9
PRESSURE TEST KIT - MAINS WATER	18	SCRAPE AWAY SET	167
PRESSURE TEST NIPPLE	147	SCREWS - STEEL	153
PRESSURE TEST NIPPLE ADAPTOR	15	SCREWDRIVER - 1000V	39
PRESSURE TEST TEE	16	SCREWDRIVER 8 PIECE SET - 1000V	40
PRESSURE VESSEL CHECKER	8	SCREWDRIVER - EXTRA LONG	31
PRESSURE VESSEL INFLATOR	6-7	SCREWDRIVER - MULTI-TEST ELECTRICAL	41
PRESSURE VESSEL PUMP	8	SCREWDRIVER - NEON MAINS TESTER	41,148
PRESSURISATION PUMP ANGLED ADAPTOR	9		
PRESSURISATION PUMP STRAIGHT ADAPTOR	9		
PRINTER - INFRA-RED	23		
PROBE HANDLE	25		
PROBES - THERMOMETER	58		
PROFESSIONAL FUSE KIT	99		
PTFE TAPE	80-81		
PUGGY TYPE GLOVES	114		
PUMP ADAPTOR	9		

S - T

SCREWDRIVER SET - INTERCHANGEABLE	40	STOVE ROPE KIT	134
SEALANT	108	STOVE SMOKE MATCHES	135
SEALANT - UNIVERSAL - HELDITE	110	STOVE SMOKE PELLETS	135
SEALANT GUN	38,109	STRAP - BUNGEE	70
SEALANT NOZZLES	151	STUMPY ADJUSTABLE WRENCH	31
SEALING DISCS	147	STUMPY SPANNER SET	31
SEALING TAPE	79	SUCTION PUMP	164
SEALING YARN FIXATIVE	113	SUPERGLUE	151
SERVICE KIT COMPLETE	101	SUPPORT POSTS - PCB	152
SERVICE MAT	118	SURFACE PROBE	58
SERVICING/COMMISSIONING REPORT - COMMERCIAL	87	SWIVEL SAW	32
SILICATE CEMENT 1500°C	108	SYSTEM GUARD - CENTRAL HEATING INHIBITOR	111
SILICONE CARBIDE ABRASIVE STRIPS	64		
SILICONE GREASE	107		
SILICONE GUN	38,109		
SILICONE SEALANT - HIGH TEMPERATURE	108	T-HANDLE HEX KEY	36
SILICONE SPRAY	104	TAGS	91-92
SILICONE TEMPORARY REPAIR TAPE	81	TAMPER PROOF RADVALVE TOPS	126
SILICONE TUBE	13	TAP ADAPTOR	18
SINGLE SIDED FOAM TAPE	79	TAPE - ALUMINIUM FOIL	81
SMOKE ALARM	28-29	TAPE - DOUBLE SIDED FOAM TAPE	79
SMOKE MATCH PLUME KIT	74	TAPE - IDENTIFICATION	76-78
SMOKE MATCHES	74-75	TAPE - INSULATION	80
SMOKE PELLET IGNITER	70	TAPE - PTFE	80-81
SMOKE PELLETS	72-74	TAPE - SEALING	79
SMOKE TEST KIT	163	TAPE - SINGLE SIDED FOAM TAPE	79
SMOKE WANDS	74	TELESCOPIC MIRROR	50
SNIFFA PLUS GAS LEAK DETECTOR	26	TEMPORARY REPAIR TAPE	81
SOCKET INTERFACE ADAPTOR	68	TERMINAL DRIVER - POZI - INSULATED	41
SOCKET SET - 31 PIECE	30	TERMINAL DRIVER - SLOTTED - INSULATED	41
SOFT BRISTLE BRUSH	63	TEST KIT - PRESSURE	14
SOLDER MATS	98	TEST KIT - SMOKE	163
SOLENOID TESTER	47	TEST LEAD SET - INSULATION	68
SOOTBREAKER	167	TEST LEAD SET - ONE-CLICK	68
SPANNER - IMMERSION	37	TEST NIPPLE ADAPTOR	15
SPANNER SET - COLOURED	31	TEST NIPPLE	147
SPANNER SET - MONOBLOC	37	TEST PLUG - SAFETY	48
SPOUT OILER	110	TEST POINT PLUG - ANALYSER	26
SPRAY-ON ADHESIVE	105	TEXTURED HAND WIPES	120
SPRING LOADED BASIN WRENCH	37	THERMA-FLOCUP	19
SPIRE NUTS	144	THERMA-FLOCUP THERMOMETER	19
STAINLESS STEEL ELEMENT	166	THERMOCOUPLE SPARES & FITTINGS	145
STAR WASHER	141	THERMOCOUPLE TESTER	49
STEADY-STREAM SMOKE WANDS	74	THERMOCOUPLE THREAD GAUGE	52
STEEL WIRE MINI BRUSH	149	THERMOMETER & PROBE KIT	56
STEEL WOOL	64	THERMOMETER - DIGITAL	56-59
STEM THERMOMETER	59	THERMOMETER - INFRA RED	57
STICKERS	90-95	THERMOMETER KITS	56,59
STOP COCK KEY	36	THERMOMETER PROBES	58
STOPWATCH	16	THERMOMETER - STEM, WATERPROOF	59
STORAGE VESSEL PAD - UNVENTED	85	THERMOMETER - STOVE PIPE	57,131
STOVE FAN - HEAT POWERED	130	TOOLS	5-70
STOVE GLASS CLEANER	132	TORCH - LED	55
STOVE & GRATE POLISH	133	TOWEL - PAPER	120
STOVE HEAT RESISTANT GLOVES	131	TREATMENT FILLING KIT	111
STOVE PAINT - BLACK	132	TRIMMING KNIFE - RETRACTABLE	32
STOVE PIPE THERMOMETER	131	TUBE BENDER	35
STOVE RANGE	129-136	TUBE CUTTER	34-35
STOVE ROPE	134	TUBE - RUBBER, NEOPRENE & SILICONE	13
STOVE ROPE FIXATIVE	134		

TURBO SOLDER MAT	98	WEIR GAUGE	19
TURBOJELL SPRAYGEL	98	WING NUTS - STEEL	145
TWISTED YARN	113	WIRE BRUSH	63
		WIRE BRUSH - MINI	149
		WIRE PROBE - FLEXIBLE	58
'U' GAUGES	10-12	WIRE STRIPPER - AUTOMATIC	43
'U' GAUGE FLUID	11-12	WOOD MOISTURE METER	131
'U' GAUGE TUBING	13	WOOL - STEEL	64
ULTI-MATE PREMIER ANALYSER	22	WORK GLOVES	114-115
ULTRA-MAN DIGITAL MANOMETER	21	WORK LIGHT	54
UNIVERSAL METER ADAPTOR PLATE	127	WORK MAT	117
UNIVERSAL SEALANT - HELDITE	110	WRAPAROUND PROBES	58
UNVENTED STORAGE VESSEL PAD	85	WRAS APPROVED SILICONE GREASE	107
UTILITIES KEY	36	WRENCH - ADJUSTABLE	31
		WRENCH - BASIN	37
		WRENCH - MICRO RATCHET	30
		WRIST STRAP - ANTI-STATIC	151
VACUUM GAUGE	162	YARN ADHESIVE	113
VACUUM TEST KIT	163	YARN - GLASS	113
VAL-U-TRADE	172-173		
VALVE CORE SCREWDRIVER	9		
VALVE CORES	9		
VAPORISING KIT	165		
VDE SCREWDRIVER - 1000V	39	Z DRIVER ANGLED SCREWDRIVER	148
VDE SCREWDRIVER 8 PIECE SET - 1000V	40	ZOOM SPOUT OILER	110
VELCRO CLEANING BLADES	63		
VESSEL CHECKER	8		
VESSEL JET PRESSURE VESSEL INFLATOR	6-7		
VIDEO BORESCOPE	51		
VINYL GLOVES	116		
VOLT SENSOR - VOLTAGE TESTER	46		
VOLT STICK	46		
VOLTAGE/CONTINUITY INDICATOR	45		
VOLTAGE DETECTOR	45		
VOLTAGE SENSOR - DUO	46		
WARNING PADS	84		
WARNING STICKERS	90-93		
WASHER KIT	101		
WASHER & OLIVE KIT	100		
WASHERS	140-143		
WASHERS - CIRCULATION PUMP	140		
WASHERS - FIBRE	140		
WASHERS - METER UNION	141		
WASHERS - STEEL	141		
WATER/AIR IMMERSION PROBE	58		
WATER & PIPE TEMPERATURE KIT	59		
WATER FINDING PASTE	164		
WATER GAUGES	19		
WATER JOINTING COMPOUND	110		
WATER PRESSURE TEST KIT	18		
WATER PUMP PLIERS	33		
WATERPROOF STEM THERMOMETER	19		
WATERPROOF WORK MAT	117		

Regin Products Ltd
8-12 Tower Square
Huntingdon
Cams
PE29 7DT
www.regin.co.uk



O-Rings



Manometer Friendly



Service Aerosols



Extra Long Reach



Pressure Vessel Pumps



Multimeters



Smoke



Voltage Detection



3 in 1 Thermometer



Cutter Tidy



Fault Finding



Innovative



Gas Detection



High Temp Sealants

Available from:

Regin Products Ltd,
8-12 Tower Square, Huntingdon, Cambridgeshire, PE29 7DT
Tel: 01480 412415 www.regin.co.uk

