



AQUALLA®

Technical Data Sheet | Mirrors

Linea Charge (800 x 700mm) 23LC87

Specification

Finish	N/A
Dimensions	800 x 700mm
IP Rating	IP44
Lumens	1160
Kelvin Rating	2700-6500K
Sensor Type	Touch
Power Rating	47.9 Watts

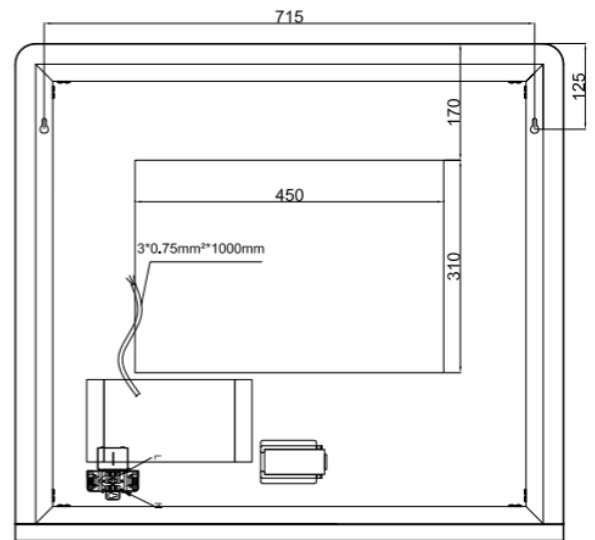
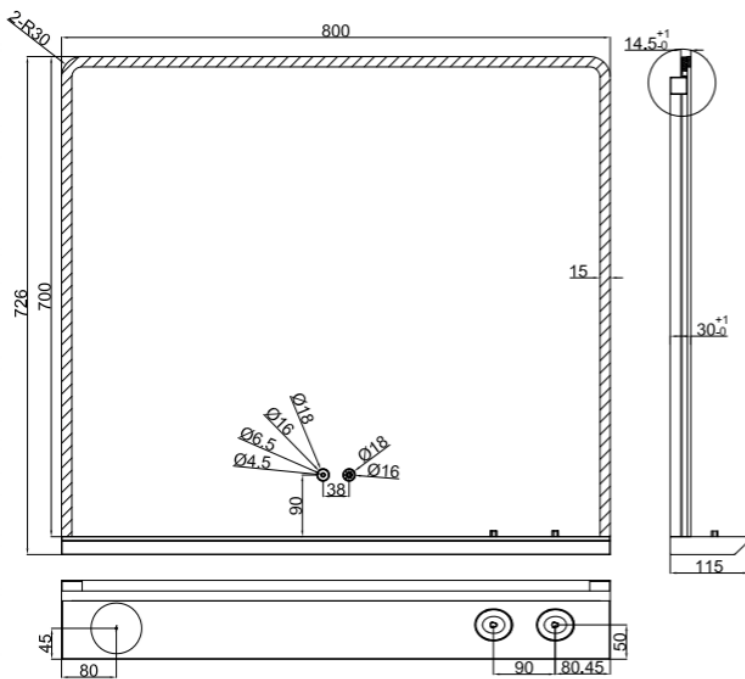

Notes

Key Features + Benefits



Years Warranty



Cool to Warm Tone



Adjustable Brightness

Aqualla Brassware

Unit 3 & 4 16 Crawfordsburn Road Newtownards County Down BT23 4EA. Technical Support – Tel: +44 (0) 28 9182 8000 Email: support@aquallabrassware.com

All information on the data sheet is correct at the time of publication. All measurements are approximate and subject to standard tolerances.

Issue No. **v1 01 2024**