

HEATRAESADIA

SMARTER | CLEANER | WARMER

Supreme 220SS & 250SS Fitting Instructions and User Guide

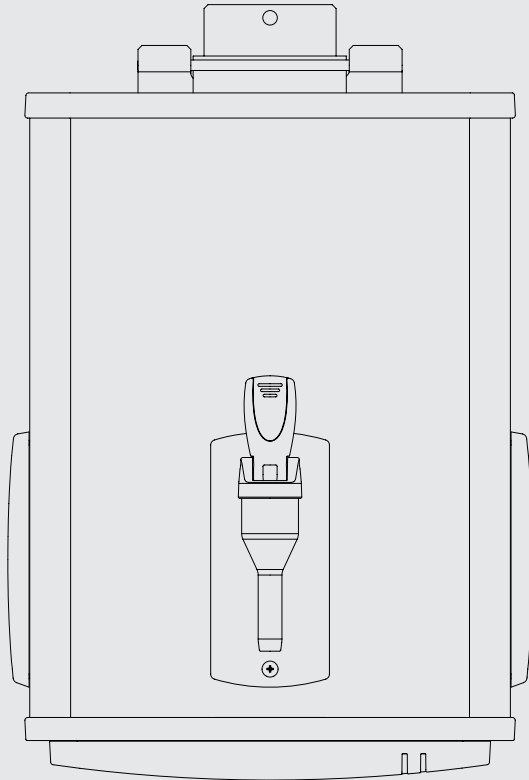

Important

Please read & understand all these instructions before commencing installation.

Please leave this manual with the customer for future reference

Please read and understand these instructions prior to installing your Supreme water heater. Instructions only detail key operations. They do not supersede national, mandatory or legal requirements which may apply to the product, installation, environment or personnel associated with servicing the Supreme. **WARNING:** electronics control by switching 'N' (neutral), in some instances neutral terminations will be at 230 volts with respect to earth.

This appliance can be used by children aged from 8 years and above and persons with reduced physical, sensory or mental capabilities or lack of experience and knowledge if they have been given supervision or instruction concerning use of the appliance in a safe way and understand the hazards involved. Children shall not play with the appliance. Cleaning and user maintenance shall not be made by children without supervision.

Particular attention should be paid to the section headed **IMPORTANT INSTALLATION POINTS**. Following installation and commissioning, the operation of the heater should be explained to the customer and these instructions left with them for future reference.

TECHNICAL SPECIFICATIONS

Electrical rating	2.8 - 3.0 kW	230 - 240V~
Nominal capacities	Model 220SS	10.0 litres
	Model 250SS	15.0 litres

Weight (full)	Model 220SS	36 kg
	Model 250SS	42 kg

Rated pressure	0MPa (0 bar)
Minimum supply pressure	0.05MPa (0.5 bar)
Maximum supply pressure	1.0MPa (10 bar)
Enclosure rated	IPX2
A-weighted sound pressure level is below 70 dB	
Nominal commissioning times (minutes) to temperature ready	
Supreme 220SS	50
Supreme 250SS	60

COMPONENT CHECKLIST

Before commencing installation check that all the following components have been supplied with your Supreme heater.

- Wall mounting bracket (hinged, 2 parts)
- M10 x 20mm set screws (2 off)
- No.12 x 1 1/2" screws (3 off)
- No.8 x 1/2" screw (2 off)
- No.12 x 2" wall plug (3 off)
- Template - to aid in positioning the heater
- 15mm x 15mm straight push-fit connector
- 15mm x 15mm 90° elbow push fit connector
- Case bracket, slotted (2 off)
- Case anchor strap
- Stabilisers (2 off)
- Tap

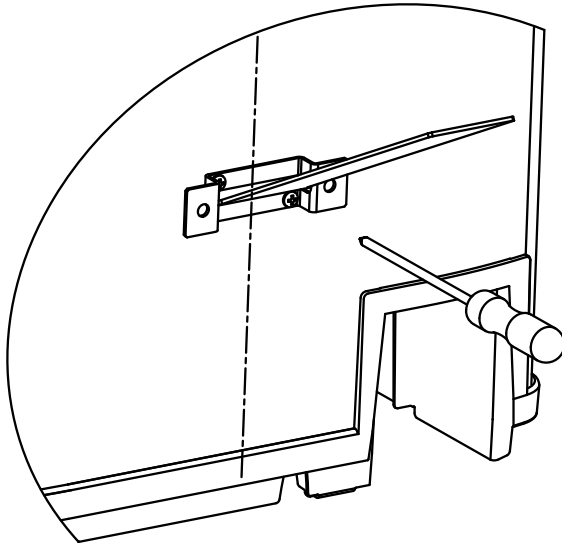

Fig.1

1.0 IMPORTANT INSTALLATION POINTS

- 1.1 The Supreme stores and dispenses water at or close to boiling point at all times it is switched on. Due caution must be taken when choosing a location for the product to minimise misuse. Locate the unit over a draining board NOT over the sink or basin.
- 1.2 Push fit connectors DO NOT grip chromed or stainless pipe.
- 1.3 The Supreme is a vented water heater. The vent pipe must never be blocked or obstructed, it must be a minimum of 15mm outside diameter pipe. Where the vent pipe length exceeds 3m the pipe diameter should be increased. The vent pipe must be laid to a continuous fall and discharge in a safe, visible position; it must discharge via a tundish or finish a minimum of 20 mm above a draining board. The vent pipe material must be capable of conveying boiling water. The vent pipe must never be connected directly to a soil pipe.
- 1.4 Wherever possible the Supreme should be supplied directly from a rising main. If fed from a cold water feed cistern, the cistern must comply with the Water Regulations Guide (clause R27.2). It should be noted that water quality may be reduced when supplied from a cistern and additional forms of water pretreatment may be necessary.
- 1.5 In hard water areas, heated water will produce limescale which will be deposited within the heater. If this is not regularly removed it will impair the operation of the heater. Where rapid and excessive scale build up is likely to occur the use of a proprietary scale reducing device may be beneficial.
- 1.6 The installation must comply with the relevant sections of the Water Regulations, Building Regulations and BS 7671 (IEE Wiring Regulations) in force at the time.
- 1.7 The Supreme will adjust for ambient (room) temperatures of between 1°C and 40°C.
- 1.8 When not in use care must be taken to prevent it freezing; if thought to be frozen it must not be switched on. It must be left to thaw and must then be thoroughly inspected to ensure it is totally thawed and undamaged.
- 1.9 The unit is not suitable for installation in an area where a water jet could be used.

2.0 INSTALLATION - MOUNTING

- 2.1 The Supreme must be vertically wall mounted using the brackets supplied.
- 2.2 Fig.2 details the outside dimensions of the Supreme unit. A template is supplied to aid positioning the heater, select hole locations according to model size. It is recommended that the unit is positioned above a draining board. If this is not possible, consideration should be given to any spillages that may occur under the heater. A drip tray is available as an accessory (Heatrae Sadia Code No. 95 970 123). The heater should be positioned at a height to suit the items being filled (flasks, pans, cups etc.). This is likely to position the base of the unit approximately 250mm above the work surface.
- 2.3 Sufficient room should be left around the heater for access for maintenance and servicing. The top should not be covered as this will reduce the efficiency of the Supreme. A novel (hinged) mounting arrangement is incorporated which can improve access. Method detailed inside bottom access panel. Leave a minimum of 250mm above the work surface or unit.
- 2.4 Ensure that the wall can support the full weight of the unit (see TECHNICAL SPECIFICATIONS) and that there are no hidden services (electricity, gas or water) below the surface of the wall.
- 2.5 Using the template mark the fixing positions and water, vent and electricity supply entry points for your model of heater. If rear entry services are to be used, the necessary holes for these should be prepared prior to hanging the unit onto its bracket.
- 2.6 The top WALL bracket takes 10mm diameter fixings. Provide fixings suitable for the application (use all 3 locations for stability). The small, slotted, WALL bracket is secured in position with the screws supplied (confirm suitability of 1 ½" x No. 12 screws and 2" plugs for use with the wall, if unsuitable due to wall type provide alternative fixings).

- 2.7 The bracket bolted to the CASE BACK of the Supreme uses the M10 x 20 set screws (2 off) supplied. The small, slotted, CASE BACK bracket is secured in position with No. 8 x ½” screws (supplied). Note orientation and slot in the case anchor strap before fitting screws (Fig. 1).
- 2.8 Fit the 2 metal and black plastic stabilisers to the M6 threaded inserts (on the back of the unit 130mm above the base) and screw fully in.
- 2.9 Remove the bottom cover by unscrewing the 3 fixing screws, lowering the front edge and lifting away the stainless plate. Lift and hang the Supreme onto the wall mounting bracket. Screw the stabilisers out to just touch the wall and then secure the case anchor strap to the wall (confirm suitability of 1 ½” x No. 12 screw and 2” plug for use with the wall. If unsuitable due to wall type provide alternative fixings).

3.0 INSTALLATION - TAPS

- 3.1 Remove the tap bezel by unscrewing the 2 screws. Check that tap boss thread and bore are clean. Remove lock nut from tap shaft, pass tap shaft through bezel and refit lock nut, take care to locate lock nut as far up the shaft as possible. Lubricate ‘O’ ring seal with clean water and gently screw tap shaft fully into boss. The tap will bottom out on the thread and can then be rotated, anti-clockwise, into a vertical position. Hold the tap and secure in position by tightening the lock nut fully; use a spanner. Secure the bezel with the 2 screws.
- 3.2 Side taps fit in the same way, after removal of the blanking plug. They are available as an accessory Part No 95 970 402 and are supplied with suitable bezels. If the front tap is being moved to the side a plain bezel will be required. **For safety, taps must only be fitted when the unit is cold.**

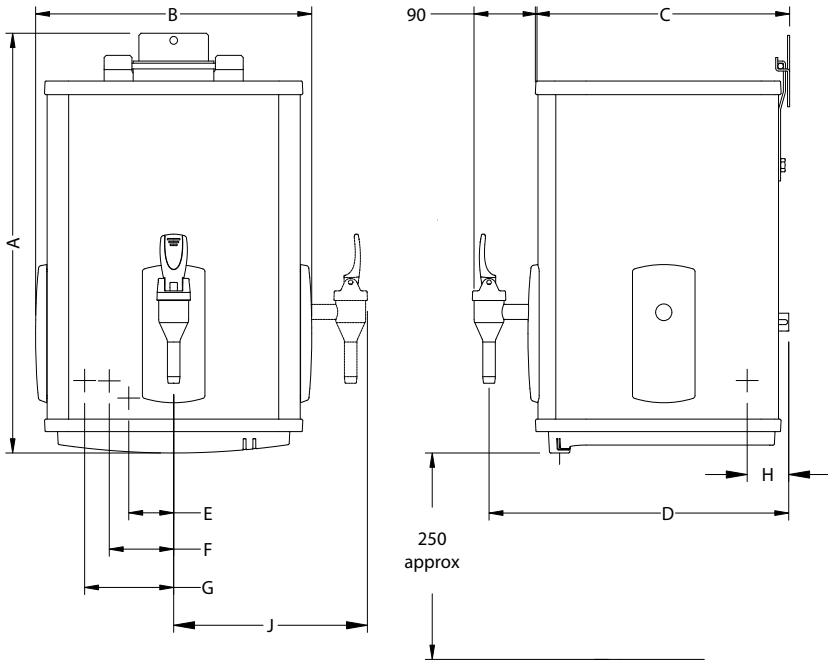

Fig.2

MODEL	DIMENSIONS (mm)								
	A	B	C	D	E	F	G	H	J
					CABLE ENTRY	VENT	INLET	INLET & VENT	
220SS	585	397	366	432	36	104	136	57	244
250SS	655	397	366	432	36	104	136	57	244

4.0 INSTALLATION - WATER SUPPLY

- 4.1 Select appropriate push fit connector for chosen entry position:
Bottom entry water - 15mm x 15mm 90° elbow.
Rear entry water - 15mm x 15mm straight.
Note: stainless or chromed pipes do NOT provide secure connections with push fit fittings (use copper pipe at all joints).
- 4.2 Push the connector fully home (28mm engagement) onto the solenoid valve inlet spigot. To remove a push fit connector the collar(collet) should be pushed towards the body of the fitting whilst pulling the connector off the pipe.
- 4.3 Connect the inlet pipe to the push fit connector ensuring it is fully pushed home (28mm engagement). After connection DO NOT make soldered joints in the pipework close to the heater, as the heat may damage the connector or the water heater itself.
- 4.4 To facilitate servicing a WRAS listed isolating valve must be fitted; the use of braided hose between the isolating valve and heater inlet is also suggested to improve serviceability.
- 4.6 Push fit connectors are supplied to allow either bottom or rear entry of services. If a combination of entry points are required an additional connector will be required as follows:
Bottom inlet, rear vent 15mm x 15mm elbow
(Heatrae Sadia part no. 95 607 510)
Rear inlet, bottom vent 15mm x 15mm straight
(Heatrae Sadia part no. 95 607 509)

5.0 INSTALLATION - VENT PIPE

- 5.1 Select appropriate push fit connector for chosen entry position:
Bottom entry vent -15mm x 15mm straight
Rear entry vent - 15mm x 15mm 90° elbow
- 5.2 Push the connector fully home (28mm engagement) onto the vent pipe connection.
- 5.3 Connect the vent pipe to the push fit connector ensuring it is pushed fully home (28mm engagement). Refer to the vent pipe requirements detailed in 1.0 IMPORTANT INSTALLATION POINTS. If a bottom entry vent pipe is used, the pipe must terminate below the unit in a safe visible position. After connection, DO NOT make soldered joints in the pipework close to the heater, as the heat may damage the connector or the water heater itself.

6.0 INSTALLATION - ELECTRICAL REQUIREMENTS

WARNING: This appliance must be earthed. It is suitable for a.c. supply only. Disconnect the electrical supply before removing the cover. Installation must be in accordance with the current local Wiring Regulations.

- 6.1 Supremes must only be connected via fixed wiring (a plug and socket must not be used).
- 6.2 A double pole isolating switch, with a contact separation of at least 3mm in both poles, should be incorporated in the electrical supply. The supply should be fused 13 Amp (for 3kw units) or 30 Amp for 6kW units).
- 6.3 The nominal cross sectional area of the supply cable must be a minimum of 1.5mm² (3kW) or 4.0mm² (6kW).
- 6.4 The outer sheath of the cable must be secured using the cable clamp provided, unless using conduit. To fit 20 mm conduit remove the cable clamp (undo 2 screws securing the clamp to the bracket and pull off clamp), fit flexible conduit tail to the metal bracket and secure with a back nut.
- 6.5 Connect the cable to the terminal block as follows:
BROWN or RED wire to terminal marked L.
BLUE or BLACK wire to terminal marked N.
GREEN/YELLOW or GREEN wire to terminal marked 
If using "Twin and Earth" cable the bare earth wire must be sleeved.
- 6.6 If Supremes are to be unused for significant periods of time, running costs can be reduced by switching the units off. It is recommended that this is done automatically by incorporating a suitable timeswitch in the supply to the unit. The use of Heatrae Sadia accessory no. 95 970 124 is recommended **for units rated up to 3kW**. The timeswitch can then be set to switch the unit on for a suitable period to allow it to heat up before it is next to be used. NOTE: A timeswitch must be capable of switching the required resistive load.

7.0 COMMISSIONING

- 7.1 The electronic control system of the Supreme has a self commissioning and calibration function. Once the heater is installed and all services have been connected, the unit should require no further adjustment before use.
- 7.2 Check that all electrical, water and vent pipe connections have been made and are secure.
- 7.3 Replace the bottom cover and secure with the fixing screws. Turn on water and electrical supply.
- 7.4 The READY indicator will flash to indicate the unit is in its “self-commissioning” mode. The water in the unit will not be hot enough to use at this stage.
- 7.5 The READY indicator will continue to flash until the unit has reached boiling and has “self-calibrated”. At this point the READY indicator will remain illuminated. If for any reason the calibration procedure is interrupted it will restart after a short delay but may result in the calibrated temperature being too low. If this occurs switch the electrical supply OFF for several seconds and then switch ON. The calibration sequence will reset. Wait for the READY indicator to remain illuminated.
- 7.6 The unit is now ready to use, however, it is recommended that the first few fills be drawn off and discarded to ensure the freshness of the water.
- 7.7 The tap sealing washer pressure has been already set. If the tap drips after commissioning adjust the spring tension so that the handle is just loose. With the handle in the vertical (off position) remove locking screw, spring washer and security tab; line up the hole in the plastic tap cap with the hole beneath it (by gently turning the handle). Insert a short, blunt, M4 screw. Increase sealing pressure (and loosen handle fit) by turning the handle clockwise. Remove the ‘short, blunt, M4 screw’; position the handle with the smoothly curved side facing you (pull on with spring return) and replace tab, washer and screw. **Note: excessive adjustment will dismantle the tap, if heated this would result in the uncontrollable release of boiling water.**
- 7.8 Check for leaks.

8.0 MAINTENANCE

NOTE: Maintenance must be carried out by competent persons. Competent - i.e. trained, experienced, qualified.

Disconnect the electrical supply before removing the covers.

WARNING: electronics control by switching 'N' (neutral), in some instances neutral terminations will be at 230 volts with respect to earth.

- 8.1 The electronic control system of the Supreme has a self-diagnostic feature which determines if the unit is operating satisfactorily. It will automatically calibrate for water quality and temperature.
- 8.2 If steam or boiling water discharges from the vent pipe the Supreme will switch off. A critical fault would render the unit unsafe to use and so will deactivate both the element and solenoid valve.
- 8.3 The Supreme incorporates an electronic scale conditioning function which will reduce the rate of scale deposition in hard water areas. However, some deposits may still occur in the storage tank; these should be periodically removed.

9.0 FAULT FINDING

SAFETY NOTE: DISCONNECT THE ELECTRICAL SUPPLY BEFORE REMOVING THE COVERS AND CARRYING OUT ANY OF THE FOLLOWING ACTIONS. DO NOT BYPASS ANY SAFETY CONTROLS.

SYMPTOM	POSSIBLE CAUSE	ACTION
No indicator lights	<ol style="list-style-type: none"> 1. If no water or heat – no power to unit 2. If hot water available – no power to indicator diodes 	<ol style="list-style-type: none"> 1. Check power supply is correctly connected and switched on and that primary cutout has not operated 2. Check connections to indicators at 4 way plug
Unit does not fill on commissioning	<ol style="list-style-type: none"> 1. If "ON" indicator not illuminated – no power to unit 2. If "READY" light flashing – water supply not turned on 3. Solenoid fault 4. Low water pressure 	<ol style="list-style-type: none"> 1. Check power supply is correctly connected and switched on and that primary cutout has not operated 2. Check water supply 3. Check operation of solenoid valve, replace if necessary 4. Check supply
Unit does not heat on commissioning	<ol style="list-style-type: none"> 1. If "ON" indicator not illuminated – no power to unit 2. If "READY" light flashing – water supply not turned on 3. Solenoid fault 4. Low water pressure 5. Element fault 	<ol style="list-style-type: none"> 1. Check power supply is correctly connected and switched on and that primary cutout has not operated 2. Check water supply 3. Check operation of solenoid valve, replace if necessary 4. Check supply 5. Check element continuity. If faulty replace
Unit does not fill after commissioning	<ol style="list-style-type: none"> 1. Level sensor fault 2. Solenoid valve fault 3. Electronic control fault 4. Low water pressure 	<ol style="list-style-type: none"> 1. Check level system earth connections 2. Check operation of solenoid valve, replace if necessary 3. Check connections to electronic control. Replace if necessary 4. Check supply
Unit does not heat after commissioning	<ol style="list-style-type: none"> 1. Element fault 2. Electronic control fault 3. Control thermistor fault – short circuit 	<ol style="list-style-type: none"> 1. Check element continuity. If faulty replace 2. Check connections to electronic control. Replace if necessary 3. Check continuity (5Kohms at 100°C , 100Kohms at 25°C)

SYMPTOM	POSSIBLE CAUSE	ACTION
Water flows from vent and primary cutout activates	<ol style="list-style-type: none"> 1. Solenoid valve fault 2. Level sensor fault 3. Electronic control fault 	<ol style="list-style-type: none"> 1. Check operation of solenoid valve, replace if necessary 2. Check level system earth connections 3. Check connections to electronic control. Replace if necessary
Steam from vent pipe and primary cutout operates	<ol style="list-style-type: none"> 1. Control thermistor fault – open circuit 2. Electronic control fault 3. Scale build up 	<ol style="list-style-type: none"> 1. Check continuity (5Kohms at 100°C , 100Kohms at 25°C) 2. Check connections to electronic control. Replace if necessary 3. Descale unit
Drips from outlet	<ol style="list-style-type: none"> 1. Incorrect spring tension 2. Scale : debris under tap seal 3. Damaged tap seal 4. Scale on tap outlet spout 	<ol style="list-style-type: none"> 1. Ensure tap headwork nut correctly adjusted 2. Remove and clean as necessary 3. Replace tap seal 4. Clean tap outlet
Water "runs on" when tap released	<ol style="list-style-type: none"> 1. Scale on tap outlet spout 2. Scale : debris under tap seal 3. Damaged tap seal 	<ol style="list-style-type: none"> 1. Clean tap outlet 2. Remove and clean as necessary 3. Replace tap seal
Stale taste to water	Unit left unused for several days	Empty and allow to refill before use
Tap sticks open	<ol style="list-style-type: none"> 1. Handle in pan filling - option 2 2. Dirt around handle pivot 	<ol style="list-style-type: none"> 1. Reset to general use - option 1 2. Clean with a stiff paint brush
Water consistently cooler than when new	<ol style="list-style-type: none"> 1. Control thermistor pocket has a covering of scale 2. Control thermistor out of calibration 3. Steam thermistor out of calibration 	<ol style="list-style-type: none"> 1. Descale the pocket surface & unit 2. Check values (5Kohms at 100°C, 100Kohms at 25°C) 3. Check values (5Kohms at 100°C, 100Kohms at 25°C)

Any faults that cannot be identified using the Fault Finding chart, or in case of doubt, contact the Heatrae Sadia Service Department (contact details on the back page.)

10.0 SPARE PARTS

The following comprehensive list of spare parts is available for your Supreme water heater. Please refer to the rating label of your heater before ordering to ensure the correct spare parts are obtained.

DO NOT REPLACE WITH PARTS NOT RECOMMENDED BY HEATRAE SADIA - THIS WILL INVALIDATE YOUR GUARANTEE AND MAY RENDER THE INSTALLATION DANGEROUS.

1.	Element plate (3kW)	95 606 001
2.		
3.	Element sealing gasket	95 611 734
4.	Start dry cutout (element)	95 612 503
5.	Primary cutout (condenser)	95 612 001
6.	Solenoid valve assembly	95 605 004
7.	Level sensor assembly (220 model)	95 612 002
8.	Level sensor assembly (250 model)	95 612 003
9.		
10.		
11.	Circuit board (220,250 models)	95 615 001
12.		
13.		
14.	Wiring harness (4way inc. diodes)	95 612 006
15.	Wiring harness (220 & 250 complete)	95 612 007
17.	Thermistors	95 612 009
18.	Outlet tap headwork (inc. handle)	95 605 006
19.	Outlet tap stem	95 605 832
20.	Outlet tap cup seal	95 611 731
21.	Outlet tap body	95 605 007
22.	Side tap bezel (plain)	95 605 008
23.	Side tap bezel (with tap hole)	95 605 018
24.	Front tap bezel (plain)	95 605 016
25.	Front tap bezel (with tap hole)	95 605 017
26.	Top cover & screws	95 614 001
27.	Bottom cover & screws	95 614 002
28.	Steam condenser assembly	95 607 001
29.	'O' ring kit	95 611 001

- | | | |
|-----|-----------------------------------|------------|
| 30. | Hose kit (low pressure) | 95 607 014 |
| 31. | Hose kit (high pressure) | 95 607 013 |
| 32. | Push fit connector 15x15 straight | 95 607 509 |
| 33. | Push fit connector 15x15 elbow | 95 607 510 |
| 34. | Fitting kit | 95 607 023 |
| 35. | Blanking plug | 95 605 100 |
| 36. | 8mm compression tee | 95 605 080 |

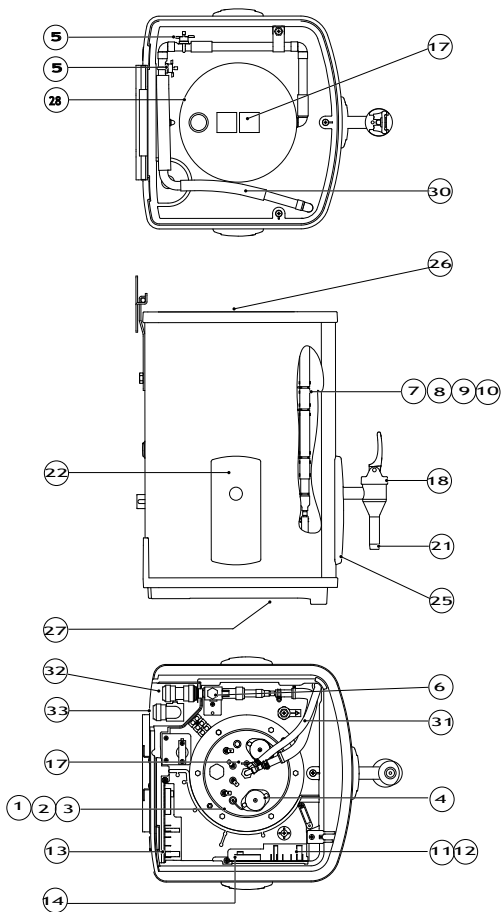

Fig. 3

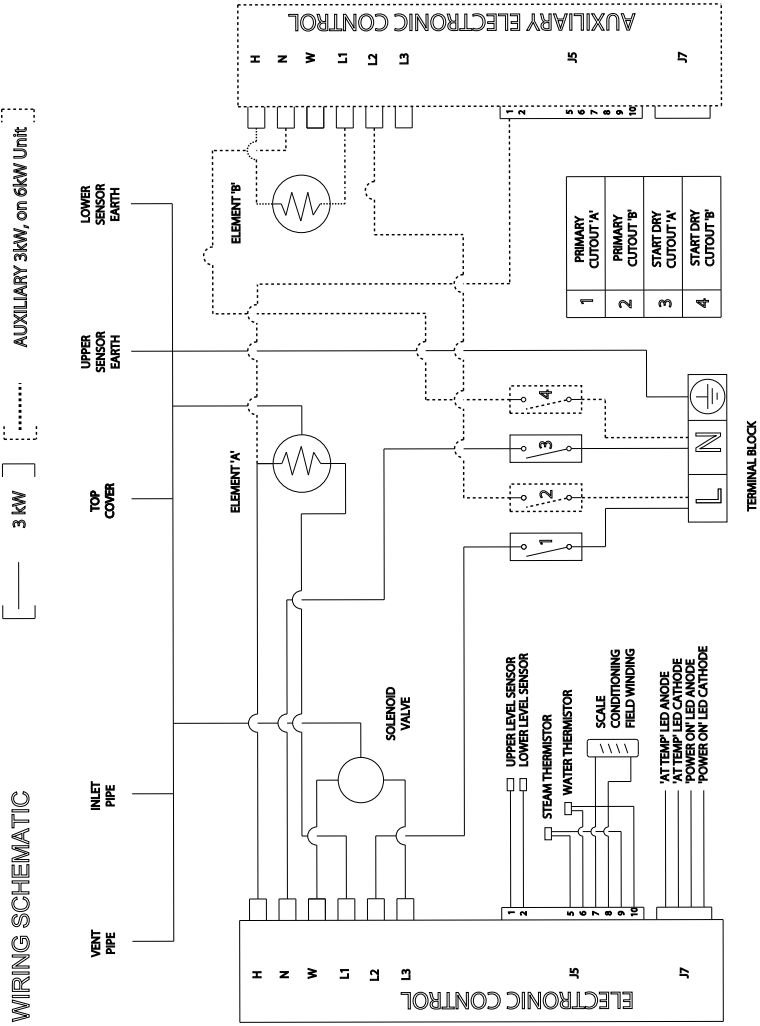

Fig. 4

11.0 USER INSTRUCTIONS

Warning - dispensed water is scalding hot - tap body reaches water temperature

- 11.1 Once installed, the filling and heating cycles of the Supreme are completely automatic.
- 11.2 To dispense the water, the tap handle should be pulled down and towards the user, a suitable container having been placed under the outlet spout. The water dispensed will at all times be boiling or close to boiling point so due caution must be taken when using the product, especially if it is likely to be used by children, aged or infirm persons.
- 11.3 The tap handle has 2 methods of operation. The design is not intended to be continually changed between options.
Option 1 for general use - Pull on with spring return. With the smoothly curved side of the handle facing you; to dispense water, pull the tap handle down and towards you, a suitable container having been placed under the outlet spout. Gently release and the spring loaded handle will move back to the "off" position (no flow).
Option 2 for filling very large pans - Pull on and push off. With the reverse face (inside) of the handle facing you; to dispense water, pull the tap handle down and towards you, a suitable container having been placed under the outlet spout. At the bottom of the stroke the handle will push over a gentle feature and remain open when released. To move back to the "off" position (no flow) gently lift the handle.
To select option 1 or 2; with the handle in the vertical (off position) remove locking screw, spring washer and security tab; twist the handle so that the required face is forwards; replace tab, washer and screw.
- 11.4 The Supreme is fitted with two indicators to give a visual indication of the unit's status.
ON Will be illuminated as long as the electrical supply to the Supreme is switched on.
READY When fully illuminated indicates that the stored water is hot enough to use.
- 11.5 The main part of the outer case is made in finger print resistant stainless steel. DO NOT use harsh cleaners. A gentle rub with a well rung out, clean, cloth and mild detergent; then a dry duster should be enough.

- 11.6 If the store of hot water is completely withdrawn, the flow rate from the outlet tap will reduce to the filling rate of the heater. This slow flow rate allows the incoming water to be instantly reheated, it does not indicate a fault with the water heater.
- 11.7 If the Supreme is not used for a few days the water may become “stale”. In these instances it is advisable to draw off the contents and discard the water at least twice to remove the “stale” water. This will ensure that “freshly” boiled water is used to make your drinks etc.
- 11.8 Similarly, if left unused it is possible that some scale residue will collect in the outlet tap. This will cause the outlet water to appear “milky” for a short while. If this condition occurs it is recommended that the first few cups are drawn off and discarded.

GUARANTEE

This Supreme water heater is guaranteed for a period of two years from the date of purchase provided:

1. The unit has been installed in accordance with these instructions and all necessary inlet, vent and electrical connections have been fitted correctly.
2. Any valves or controls are of Heatrae Sadia recommended type.
3. The unit has not been tampered with and has been regularly maintained as detailed in the maintenance instructions.
4. The unit has been used only for heating potable water.

The unit is not guaranteed against damage by frost or due to the build up of scale. Please note that if Heatrae Sadia personnel or agents are requested to descale a unit, this work will be chargeable.

This guarantee does not affect the statutory rights of the consumer.

ENVIRONMENTAL INFORMATION

This product is manufactured from many recyclable materials. At the end of its useful life it should be disposed of at a Local Authority Recycling Centre.

WEEE Declaration

Disposal of Waste Equipment by Users in Private Households in the European Union.



■

This symbol on the product indicates that this product must not be disposed of with your other household waste. Instead, it is your responsibility to dispose of your waste equipment by handing it over to a designated collection point for the recycling of waste electrical equipment. The separate collection and recycling of your waste equipment at the time of disposal will help to conserve natural resources and ensure that it is recycled in a manner that protects human health and the environment. For more information about where you can drop off your waste equipment for recycling, please contact your local city office, your household waste disposal service or the company where this product was purchased.

HEATRAESADIA

SMARTER | CLEANER | WARMER

Electric Water Heating Co.

2 Horsecroft Place
Pinnacles
Harlow
Essex CM19 5BT
Tel: 0845 0553811
E-Mail: sales@ewh.co.uk

SPD

Special Product Division
Units 9 & 10
Hexagon Business Centre
Springfield Road
Hayes
Middlesex UB4 0TY
Tel: 020 8606 3567

Parts Center

Tel: 0344 292 7057
www.partscenter.co.uk

Newey & Eyre

Unit 3-5 Wassage Way
Hampton Lovett Ind. Estate
Droitwich, Worcestershire
WR9 0NX
Tel: 01905 791500
Fax: 01905 791501

UK Spares Ltd

Unit 1155
Aztec West
Almondsbury
Bristol BS32 4TF
Tel: 01454 620500

Alternatively contact your
local supplying merchant
or wholesale branch or use
our online stockist finder at
www.interpartspares.co.uk

SPECIFICATION ADVICE HOTLINE

t | 01603 420220 e | specifier@heatraesadia.com

AFTER SALES SERVICE

t | 0344 871 1535 e | customer.support@heatraesadia.com

w | heatraesadia.com



OUR NATIONWIDE NETWORK OF CUSTOMER SUPPORT ENGINEERS

Heatrae Sadia has its very own dedicated nationwide network of highly trained customer support engineers so you can have peace of mind that we're always here to help.

PRODUCT RANGE

Full specification details on all our products are available to download from our website.

To support our corporate responsibility and sustainability charters and reduce our printed material we encourage you to download product brochures from our website.

In designing these files we have taken into account the need to access data on screen.

If you would like to receive a printed copy of our full product catalogue please call our literature hotline on 01603 420127.

Heatrae Sadia Heating may introduce modifications to their products from time to time. Consequently, the details given in this brochure are subject to alteration without notice.

Please follow us online:



PN 36005913 Issue 08

© Heatrae Sadia 2022