

STAINLESS STEEL INSET SINKS 420/400

Installation Instructions & Aftercare Information

1328-01

Due to our policy of continual improvement, we reserve the right to change specifications without prior notice.

Installer

Please leave this leaflet with the user, as it contains valuable after care advice.

Notes

- ⚠ Please take care of sharp metal edges before and during installation.
- ⚠ During installation, take care to protect the sink from scuffs and scratches.
- ⚠ Avoid straining and overtightening of all plumbing fixtures connected to the sink.
- ⚠ Carefully check that the moulding and edges of the sink are dead level so that water will flow off the drainer.
- ⚠ We recommend that the worktop opening is sealed using waterproof sealant, paint or a similar material.
- ⚠ The clamping brackets are suitable for worktops of between 27 – 43 mm thickness. If your worktop is a different size then it may require packing under the clips or rebating.

Installation

1. Position the cut-out template on the worktop (**Fig. 1.1**). Make sure the cabinet framework will clear all parts of the sink. Using a soft, sharp pencil draw around the template as accurately as possible. Remove the template and retain for later.
2. Drill as large a hole as possible inside the cutting line. Using a padsaw, jigsaw or similar, cut out the opening up to the cutting line.
3. The sinktop should then be placed in position to check for final fitting.
4. On the worktop, cut out the overflow area using either of the following methods (**Fig. 1.2**). On the worktop, mark out the position of the overflow pocket.

Method 1	Method 2
<p>a. Route the pocket to within 7mm of the front face of the worktop.</p> <p>b. If router is not available then follow Method 2</p>	<p>a. Drill; mark the drilldepth to within 7mm of the front face of the worktop (care should be taken not to drill right through the worktop).</p> <p>b. Chain drill the pocket and then chisel out.</p>

6. Turn the bowl upside down and fill the outer perimeter with a suitable sealing compound, (silicon sealant etc) (**Fig. 1.3**).
7. All cut edges of worktops must be sealed with a waterproof varnish or seal.
8. Lower the sink into the worktop, pressing it firmly in position, preferably using weights evenly distributed around the perimeter. **It is recommended to tighten in the order of sequence shown in (Fig. 1.1).**
9. Secure bowl using nuts and washers supplied **DO NOT** over tighten (**Fig. 1.4**).
10. Remove excess sealant.

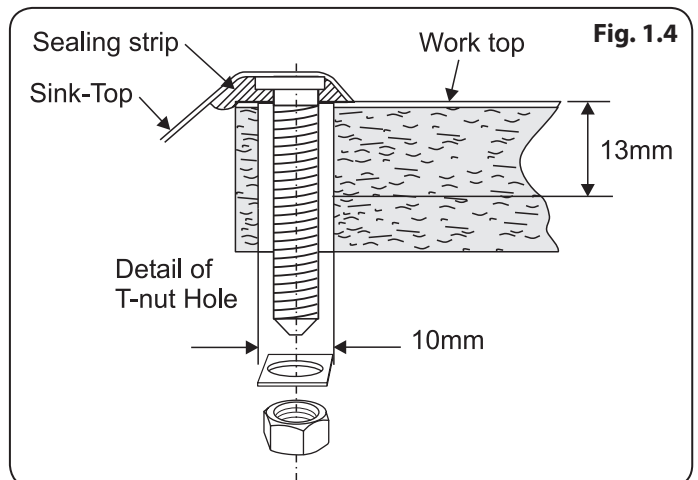
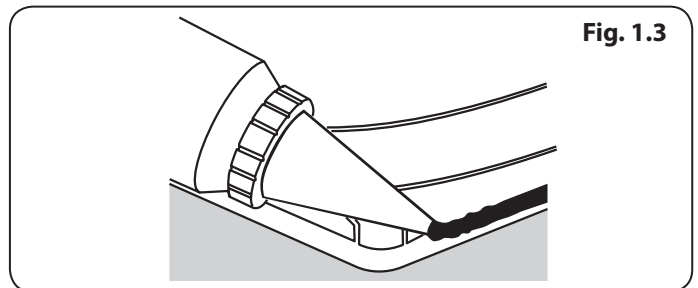
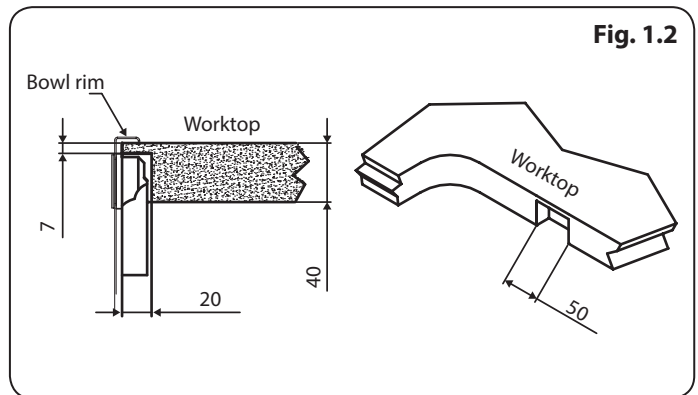
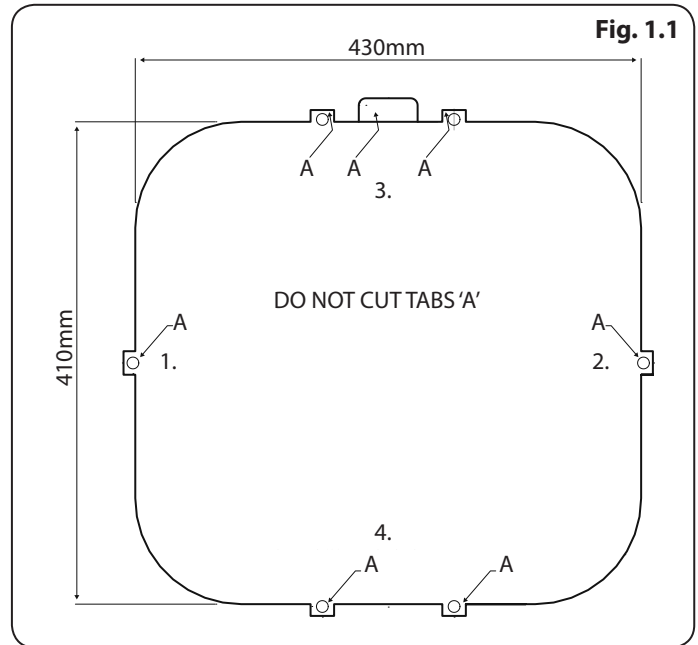

After Care

Day-to-day care

Routine cleaning of your stainless steel sink is easy if the following simple procedure is followed:

After use wipe the bowl and drainer with a soft damp soapy cloth and rinse with clean water. In hard water areas, an application of proprietary cream cleaner or stainless steel sink cleaner will avoid any build-up of a dull film of waterborne deposits.

Although stainless steel is an extremely durable material and will withstand a great deal of hard use, it can be scratched by hard or sharp objects. If the surfaces are to be kept in a blemish free condition reasonable care should be taken when handling such items.

Cleaning

Always use a soft cloth. The use of coarse grit scouring powders or soap-filled wire wool cleaning pads is not recommended, since both will mark the surface of the sink. Wire wool pads can leave tiny fragments of wire embedded in the surface and these can rust and leave small brown rust stains. Vigorous rubbing with a soft cloth with a proprietary cream cleaner or stainless steel sink cleaner will remove these stains.

Always remove wet cleaning aids (cloths, containers, etc.) from the sink surface after use to avoid the formation of water marks and rust stains.

Discolouration and heavy staining

In most cases, staining of stainless steel is due to something being deposited on the steel rather than an attack on the material itself. The most common cause of staining is the build-up of a thin film of waterborne deposits on the sink surface, often first seen as a rainbow effect. The build-up of such a film can be avoided by drying the surface of the sink after use.

Should such a film appear, apply proprietary cream cleaner or stainless steel sink cleaner neat and rub vigorously with a damp cloth along the length of the sink surface. After cleaning, rinse thoroughly with clean water and dry.

Wire wool products and ferrous water supply pipes can leave minute ferrous particles adhered to the sink surface. Since stainless steel under normal conditions does not rust, these particles can cause the appearance of small brown rust stains. These stains can be removed using the procedure described above.

10 YEAR GUARANTEE

We guarantee to replace any stainless steel sink that breaks due to material or manufacturing defects within 10 years from the date of purchase.

The guarantee does not cover normal wear and tear occurring through use of the product.

For the guarantee to apply the owner must follow the use, care and cleaning instructions provided.

Accessories and waste fittings are **NOT** included in this guarantee.

Caution!

Certain household products contain substances that will attack the stainless steel surface. They are:

1. Bleaches

Most common domestic bleaches contain Chlorine in the form of a hypochlorite. Chlorine attacks the microscopic Chromium Oxide film on the surface and can cause pitting of the surface.

Bleaches should always be used in the prescribed strength specified by the manufacturers. Undiluted bleaches can cause pitting and staining of the surface and should be immediately rinsed off with plenty of clean water.

All cleaning agents containing hypochlorites are unsuitable for use with stainless steel and, even highly diluted, can cause pitting under certain circumstances. For this reason we strongly recommend that the sink is not used for soaking clothes or cleaning clothes in hypochlorite solutions for long periods.

2. Silver dip cleaners

These are particularly harmful since they contain strong acids that can cause discolouration and pitting. The first sign of this is an iridescent rainbow stain that turns an etched dull grey colour.

Should any silver dip cleaner come into contact with the surface of the sink it should be immediately rinsed off with plenty of clean water.

3. Corrosive foodstuffs

Fruit juices, damp salt, vinegar, ready made mustards, pickle and mayonnaise can cause pitting and corrosion if left in contact with the stainless steel surface for long periods.

4. Acids

Sulphuric, Hydrochloric and other strong acids will cause pitting corrosion, as will photographic developing liquids. If contact occurs immediately wash off with plenty of clean water.



LEISURE
sinks

Meadow Lane, Long Eaton,

Nottingham, NG10 2GD, England

Tel: +44 (0) 115 946 4000 Fax: +44 (0) 115 973 6602

E-mail: consumers@rangemaster.co.uk

www.leisuresinks.co.uk



13

EN 13310 : 2015

Kitchen sink made of: Stainless Steel

Cleanability: Pass

Load resistance: NPD / N/A

Durability: Pass