

# **BAR MIXER BRACKET**

**(built-in, push-fit connector)**

**For Bar Mixers & Bath Shower Mixers**

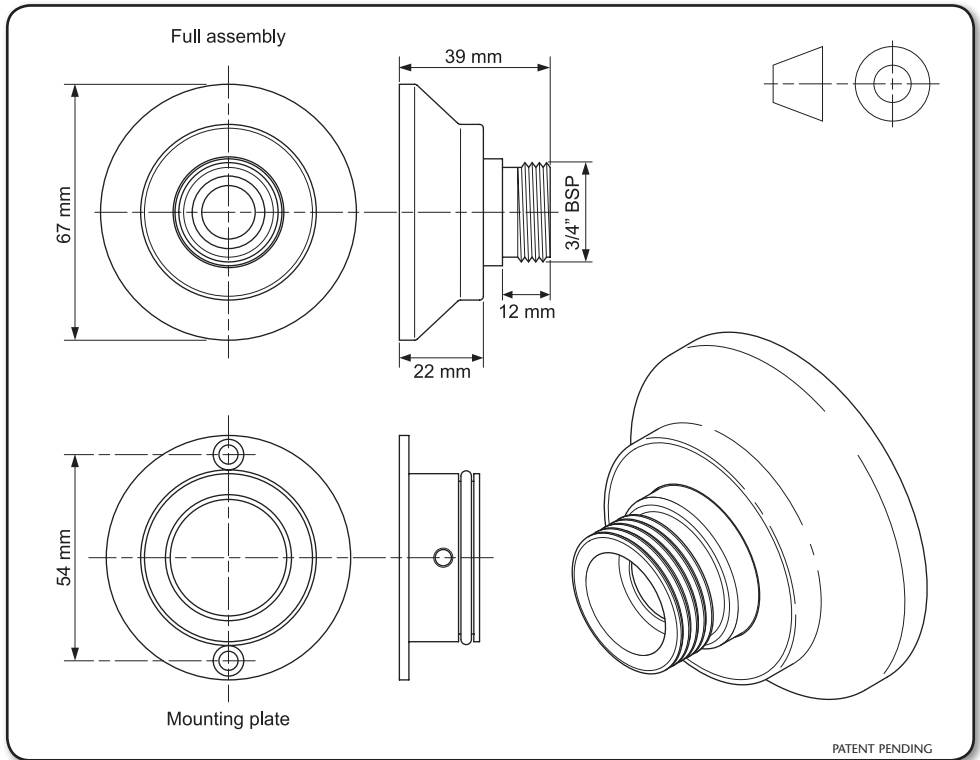

## **Installation Instructions**

INSTALLERS PLEASE NOTE THESE INSTRUCTIONS ARE TO BE LEFT WITH THE USER

2180558L - July 2018

Fig. 1

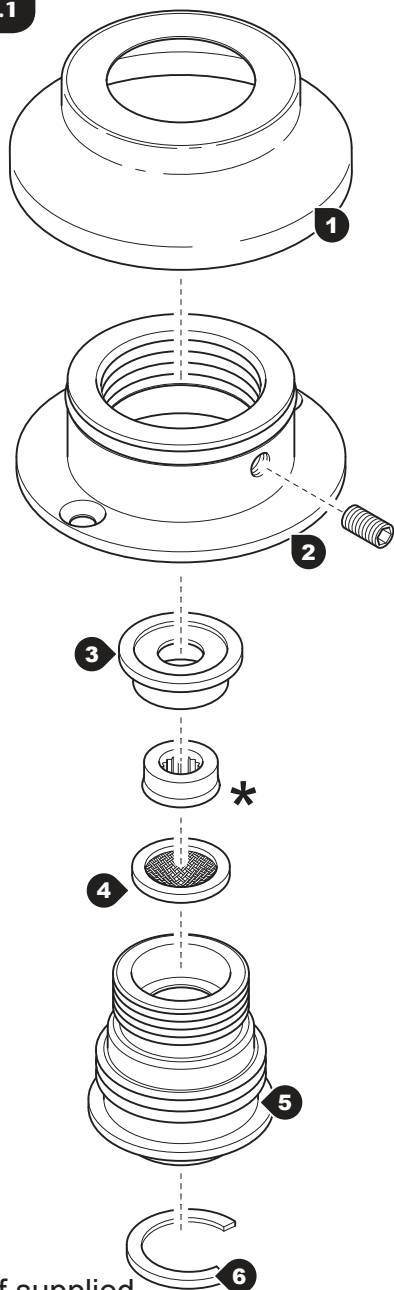

\*If supplied

## INTRODUCTION

This guide contains all the necessary fitting instructions for your (built-in pipework, push-fit connector) bar mixer bracket. The bracket has been designed to be surface mounted, using 15mm pipework and can be used with bar mixers or bath shower mixers with  $\frac{3}{4}$ " BSP fixings.

Please read the instructions carefully. Read through the whole of this guide before beginning installation.

The bracket installation must be carried out by a suitably competent person and in the sequence of the instruction book.

Care taken during the installation will provide trouble free operation from the bracket.

## SAFETY WARNINGS

- a. Layout and sizing of pipework must be such that when other services are used, pressures at the mixer control inlets do not fall below the recommended minimum.
- b. **DO NOT choose a position where the mixer shower could become frozen.**
- c. **DO NOT connect to any form of tap or fitting not recommended by the manufacturer.**
- d. Conveniently situated service valves in each inlet supply must be fitted as an independent method of isolating the bracket should maintenance or servicing be necessary.

Refer to the mixer installation guide for further information.

Replacement parts can be ordered from Customer Service.

### ⚠ WARNING ⚠

The threads of number 6 (push-fit connector) are sharp. The use of gloves or a suitable rag is recommended when handling the item, to avoid being cut by the threads.

## COMPONENTS

The bracket is supplied as shown in **fig.1** and comprises of the following:

1. Cover trim - x2
2. Mounting plate and grub screw - x2
3. Plastic seal - x2
4. Filter - x2
5. Push-fit connector - x2
6. Locking clip - x2

## PRIMARY CONSIDERATIONS

Please consider the following points before beginning the installation:

- The brackets must be mounted onto a surface that is both solid and strong enough to support the final assembly of brackets and bar mixer.
- The push-fit connectors can be used with either 15mm copper or plastic pipework.  
**DO NOT use chrome plated pipework.**
- When installed, the pipework should not be fixed within one metre of the bracket.
- When installed, the pipework must be backed by a solid structure. When fitting the push-fit connectors, the pipework will need to resist the applied force.
- Clearance should be provided behind the finished wall, at the point at which the pipework exits the wall, to allow the pipe to be moved in and out of the wall by a minimum distance of 4mm. **This distance should be a measure of total travel of the pipe between a solid structure and the rear of the finished wall.** This clearance will allow the pipework to move when the mounting plate is assembled onto the push-fit connector, ensuring that the seal to the pipework remains undisturbed (**fig.2**).
- The pipes that enter the brackets should be cut using a suitable pipe cutter and deburred.  
**DO NOT use a hacksaw or other cutting tool that may damage the outer surface of the pipework as this may prevent a good seal to the push-fit connector.**

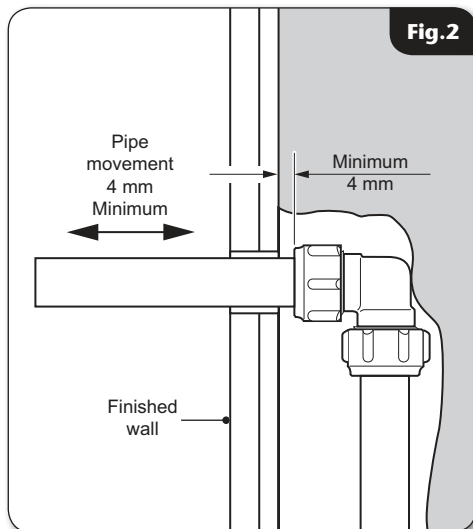

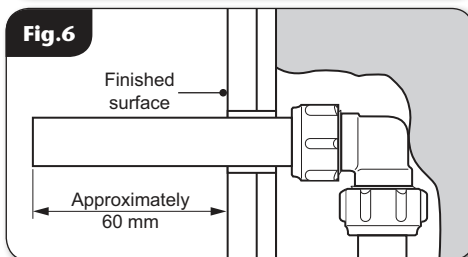
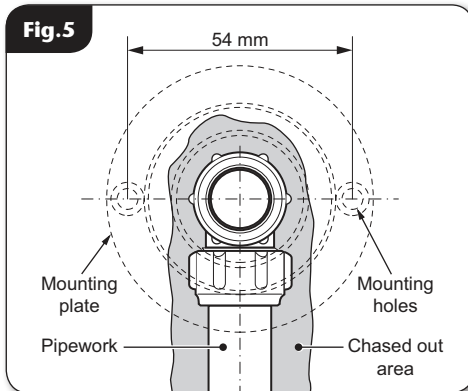
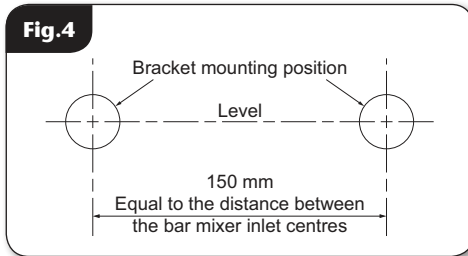
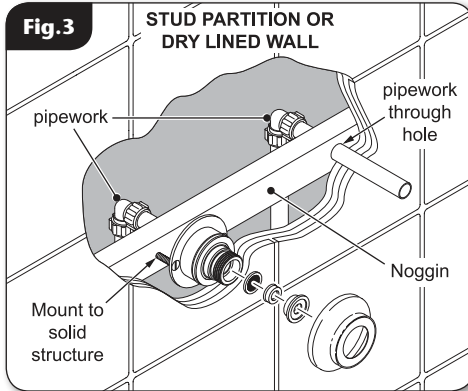

## INSTALLATION

**IMPORTANT:** These bar mixer brackets are designed to be mounted onto a solid structure. If installing to a stud partition wall, dry lined wall or similar, it is recommended that the brackets are secured to the studs or noggins. In this case, the pipework to the brackets should pass through the support studs or noggins via a suitably sized hole (**fig.3**).

Decide upon the mounting position of the brackets on the wall and mark the centres. Check the mounting marks are level and that the distance between them is equal to the distance between the bar mixer inlet centres (**fig.4**).

Mark the route of the pipework to the brackets.

Remove the plaster and brickwork (or plasterboard) to the depth required and chase out additional areas of the wall to allow for the incoming pipework. Make sure that enough solid structure of wall remains around the chasing to accommodate the mounting plate wall plugs and screws (**fig.5**).

Complete the pipework to the bracket mounting points. Leave an excess of pipe protruding out of the wall of approximately 60mm as measured from the face of the finished wall or tiles (**fig.6**).

Flush the pipework through to remove any debris. Check for leaks and remedy as necessary.

Make good the wall and tiles. Make sure that the pipes exiting the wall are free and can move in and out of the wall by a minimum distance of 4mm (**fig.2**).

## Bar mixer bracket (built-in, push fit connector)

Push each pipe into the wall until it stops against the depth of chasing. Measure 29mm from the face of the finished wall or tiles and mark the pipe.

Using a pipe cutter, cut the pipe at the 29mm mark and deburr.

**IMPORTANT:** When the pipework is at rest against the depth of chasing the length of pipe protruding from the wall should be between 30mm MAXIMUM and 28mm MINIMUM from the face of the finished wall or tiles. (fig.7).

Make sure the outer surface of the pipes are clean and free of any debris or damage. Clean the surface if necessary.

**IMPORTANT:** Press a push-fit connector onto each pipe until the pipe is pushed past the O'ring and reaches the stop within the connector. This can be visually checked by viewing the pipework through the push-fit connector outlet (fig.8). Insert locking clips onto hot and cold water push fit connections.

### Fitting the mounting plate

Guarantee that the locking clips are in place before starting this procedure.

Screw the mounting plate onto the push-fit connector until it reaches the stop and begins to turn the connector itself (fig.9).

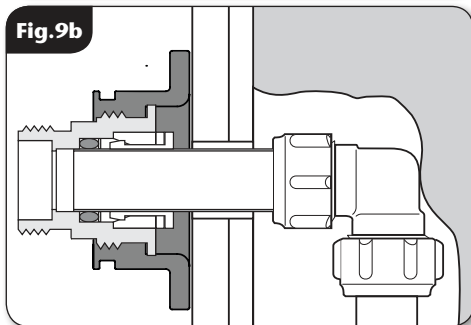
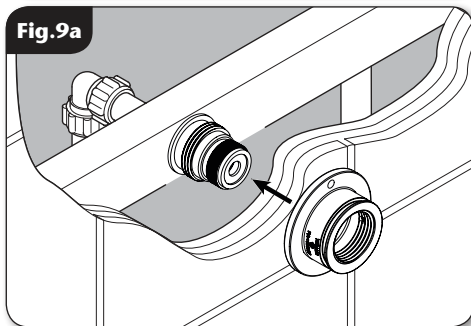
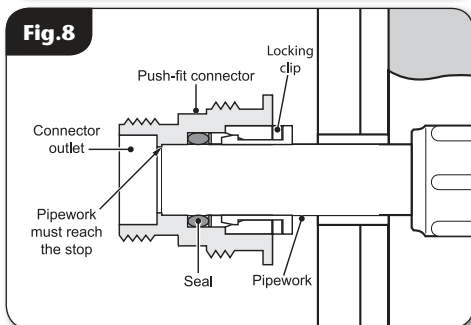
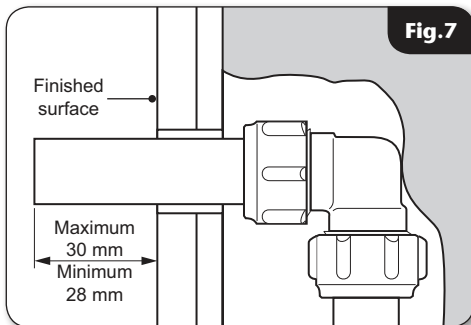

## Bar mixer bracket (built-in, push fit connector)

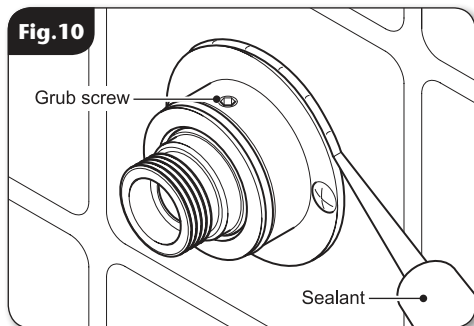

Align the mounting plate fixing holes to the intended position and mark the holes.

Remove the mounting plate. If necessary, hold the push-fit connector stationary when unscrewing the mounting plate.

Drill and plug the wall. An appropriate drill bit should be used. If the wall is brick, plasterboard or a soft building block, appropriate wall plugs and screws should be fitted.

Re-assemble the mounting plate onto the push-fit connector and secure the mounting plate to the wall.

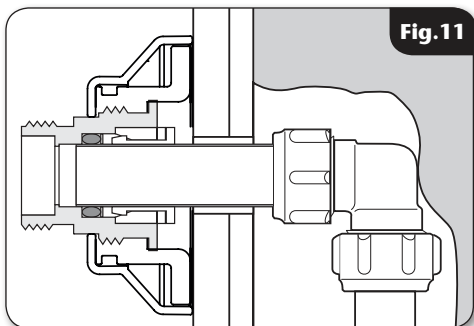

Insert the grub screw into the mounting plate and tighten to secure the connector (**fig. 10**).

Using a suitable sealant, seal the joint between the mounting plate and the wall or tiles to prevent water entering the wall. (**fig. 10**). Wipe away any excess sealant which may obstruct the fitting of the cover trim.

Push-fit the cover trims onto the mounting plates. A smear of liquid soap on the seal will ease this procedure (**fig. 11**).

Fit the seals into the push-fit connector outlets (**fig. 12**).

Fit and secure the bar mixer to the connectors.

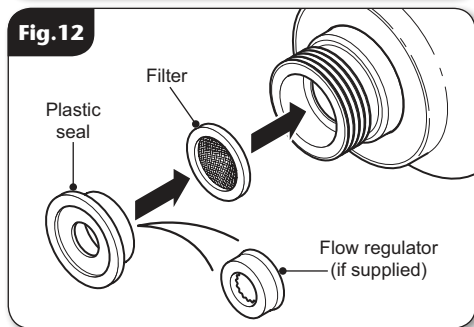

## Bar mixer bracket (built-in, push fit connector)

### Spare parts

Ref. Description	Part No.
1. Cover trim .....	7054424
2. Mounting plate.....	7054425
3. Grub screw .....	20800960
4. Plastic seal.....	7053573
5. Flow regulators are available from Triton at the following ratings: (3 Ltr/min).....	22010310
(4 Ltr/min).....	22011740
(5 Ltr/min).....	22011750
(6 Ltr/min).....	22011760
(7 Ltr/min).....	22011610
(8 Ltr/min).....	22011280
(12 Ltr/min).....	22013060
6. Filter .....	7123574
7. Push-fit connector.....	86100057
8. Locking clip: .....	7054972

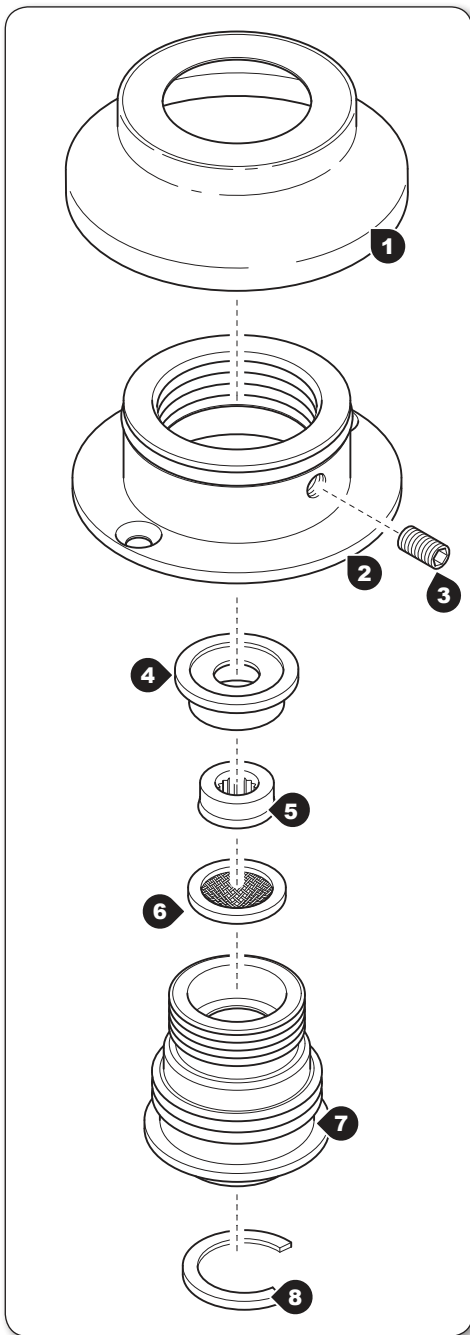

## TRITON STANDARD GUARANTEE

With the exception of accessories, Triton guarantee the product against all manufacturing defects for a period of **1 year** (for domestic use only) from the date of purchase, provided that it has been installed by a competent person in full accordance with the fitting instructions.

All accessories such as shower heads, hoses and riser rails carry a **1 year** parts only guarantee against manufacturing defects.

Any part found to be defective during this guarantee period we undertake to repair or replace at our option without charge, so long as it has been properly maintained and operated in accordance with the operating instructions and has not been subject to misuse or damage. This product must not be taken apart, modified or repaired except by a person authorised by Triton. This guarantee applies only to products installed within the United Kingdom and does not apply to products used commercially. This guarantee does not affect your statutory rights.

**For the latest Terms & Conditions please see: [www.tritonshowers.co.uk/terms](http://www.tritonshowers.co.uk/terms)**

Triton Showers  
Triton Road  
Nuneaton  
Warwickshire CV11 4NR

Triton is a division of Norcross Group (Holdings) Limited

**Customer Service: 024 7637 2222**

**Trade Installer Hotline: 024 7637 8344**

**[www.tritonshowers.co.uk](http://www.tritonshowers.co.uk)**

**E-mail: [serviceenquiries@tritonshowers.co.uk](mailto:serviceenquiries@tritonshowers.co.uk)**