

Luca - Tall Basin Mixer

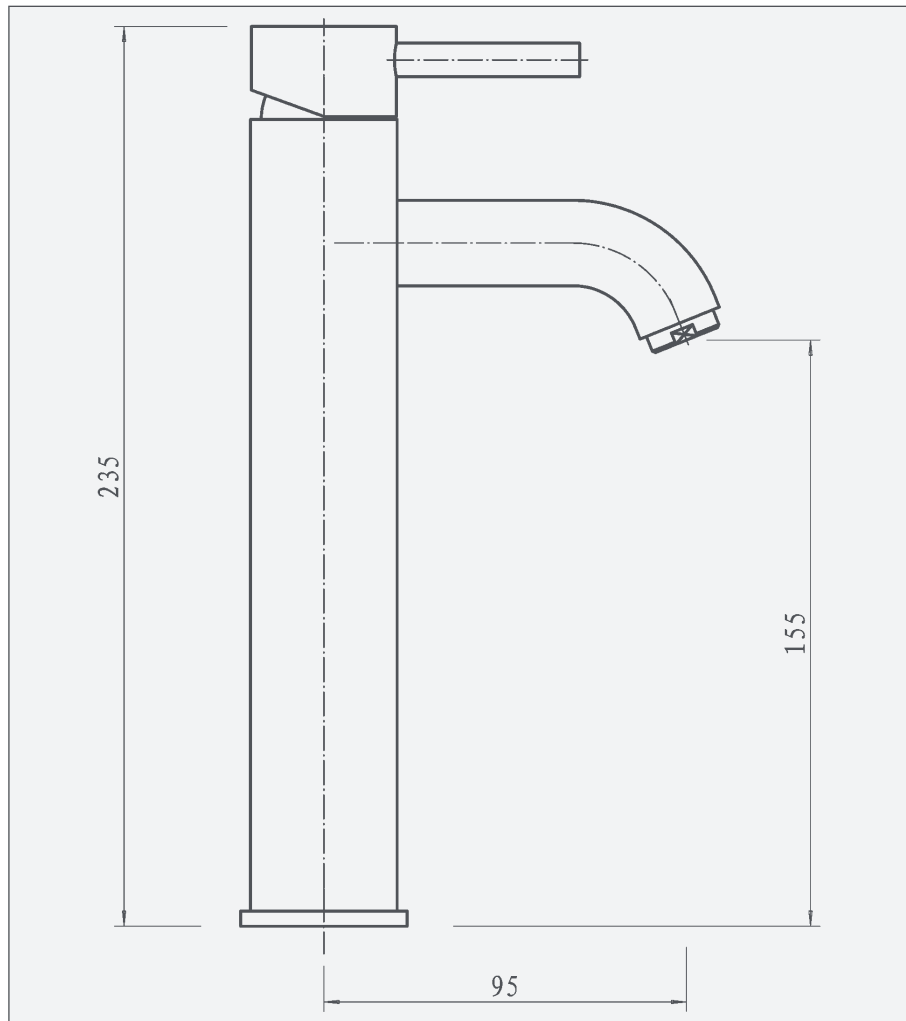

Luca Tall Basin Mixer

Code: LU-TB

Features

- Supplied with domed clicker waste and flexible tail water inlets
- Includes Neoperl flow straightener to ensure smooth flow
- 10 year warranty (2 year on cartridge)
- Discreet etching for hot and cold
- Hot and cold indicator stud supplied as standard option

Technical Details

- 1 tap hole basin mixer -chrome
- 1/2" BSP inlets



Operating Pressure	0.2 bar	0.5 bar	1 bar	2 bar
Flow Rate (L/min)	2.5	5.0	7.5	11.2

Unit 5, Kiltonga Industrial Estate,
Newtownards, Co Down,
Northern Ireland. BT23 4TJ

Sales Enquiries
Email: info@aquallabrassware.com

Tel: +44 (0) 28 9182 8000
Fax: +44 (0) 28 9181 2888

Technical and Aftersales
Email: support@aquallabrassware.com



www.aquallabrassware.com