

TOILET SEATS

► Hinge fitting instructions for Emerald and Sapphire

CARE AND CLEANING INSTRUCTIONS

- Wipe around the pan, cistern, seat and cover with a soft damp cloth.
- **DO NOT** use scouring powder, scouring pads or abrasive cloths as this may scratch the surface of the seat.
- The seat should be cleaned using warm soapy water.
- The hinges should be cleaned using soap, or a mild detergent. After cleaning the hinges should be rinsed with clean water and dried.
- Never use bleach, concentrated cleaners or acids on the hinges as this will cause discolouring and pitting.
- Take care not to splash the hinges when using bleach in the toilet bowl.
- Due to continuing product development, we reserve the right to update and amend technical details without prior notice.
- **DO NOT STAND ON THE SEAT COVER AFTER FITTING.**

Sapphire

- Identify which slot in the base plate the bolt should be put in, to ensure the best fit of the seat to the pan.
- Slide hinge base plate with assembled parts into rear of hinge cover until the two pronged clips click into position either side of the hinge cover.
- Place seat with assembled hinges onto WC pan so that the plastic bolts protrude through the fixing holes at the rear of the pan.
- Secure using plastic wing-nuts from underside of WC pan, until almost finger tight.
- Adjust seat to required position on WC pan and firmly tighten plastic wing-nuts.

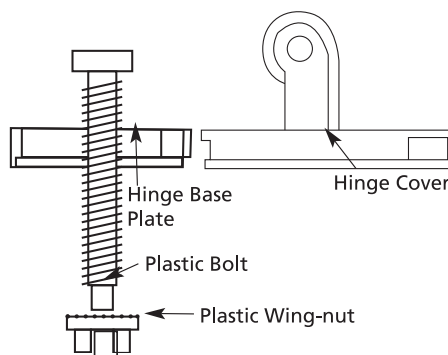

Code:	PM01EMSP
Issue:	02
Date:	15/02/19

WIRQUIN Ltd.

Warmworth Halt Industrial Estate, Warmworth, Doncaster DN4 9LS
Technical/Aftersales Tel: 0044 (0) 333 222 4488
Email: aftersales@wirquin.co.uk
www.celmac-wirquin.co.uk

wirquin
Celmac Macdee

Emerald Plastic Bottom Fix Hinge

- First identify which slot in the base plate the bolt should be put in to ensure the best fit of the seat to the pan.
- Close hinge cover and ensure both corner catches are fully engaged.
- Place seat with assembled hinges onto WC pan so that the plastic bolts protrude through the fixing holes at rear of pan.
- Secure with plastic wing nuts from underside of WC pan, until almost finger tight.
- Adjust seat to required position on WC pan and firmly tighten plastic wing-nuts.

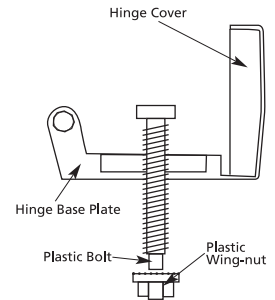

Emerald Metal Top Fix Hinge

- Attach rubber gasket to the bottom of each hinge (figure 1).
- Place the rubber sleeves into the holes in the toilet pan (figure 2).
- Identify which slot in the base plate the bolt should be put in, to ensure the best fit of the seat to the pan.
- Using a suitable screwdriver, tighten the bolt down onto the hinge. Take care to ensure the seat stays in the correct position (figure 3).
- After final tightening, place the chrome cover over the hinge base. Make sure it snaps securely into place (figure 4).

