



# Grant Renewable Technologies

Multiple package solutions.  
All from Grant.







Grant Engineering has been designing and manufacturing reliable, efficient and innovative heating products since 1978. Specialising in condensing oil-fired boilers and an expanding range of renewable appliances including air source heat pumps, solar thermal systems and hybrid technologies, the Grant brand has established a reputation for quality that is second to none.

Here at Grant, we combine precision engineering, innovation, performance and value for money to produce sustainable heating solutions that are trusted by installers and homeowners alike. While the technology is sophisticated, Grant products are easy to install, straightforward to maintain and backed-up by excellent after-sales support. When customers choose Grant, they also get the added peace of mind that comes with the excellent reliability and superb efficiencies of our products.

At the heart of everything we do is continuous product development. Every Grant product incorporates the latest technologies and materials which enable them to exceed performance and environmental standards ensuring that they make the best use of our natural resources. Consequently, Grant products meet the heating needs of tomorrow, today.

**Think Heating. Think Grant.**

## Contents

---

<b>Package Solutions by Grant</b>	<b>4</b>
<b>Aerona<sup>3</sup> Air Source Heat Pumps</b>	<b>8</b>
Aerona <sup>3</sup> R32 range introduction	10
Performance & noise levels	12
Aerona <sup>3</sup> packs	13
VortexAir Hybrid	14
Accessories	16
ErP & hot water packages	17
Aerona <sup>3</sup> technical specifications	18
VortexAir Hybrid technical specifications	19
<b>QR Cylinders</b>	<b>20</b>
QR range introduction	22
QR cylinder range overview	23
QR cylinders technical specification	24
<b>Uflex Underfloor Heating</b>	<b>28</b>
Underfloor heating introduction	30
Uflex range	32
Uflex MINI range	33
Controls	34
Controls accessories	38
<b>Afinia Aluminium Radiators</b>	<b>40</b>
Afinia range introduction	42
Afinia technical specifications	43
<b>Grant Solar Thermal</b>	<b>44</b>
Solar thermal introduction	46
Sahara solar range	48
System design	49
Components	50
CombiSOL & WinterSOL	51
Guarantees	52
<b>Product list</b>	<b>54</b>

## Package Solutions by Grant

Renewable technologies are becoming increasingly popular amongst homeowners who want their property to be heated by a sustainable system. Consumer demand and industry legislation are driving manufacturers to develop products which have less impact on the environment, helping householders to reduce their carbon footprint and to lead greener lifestyles. Consequently, products which offer viable alternatives to traditional fossil fuel heating systems are playing a more prominent role in today's market with householders opting to install cleaner, renewable heating products within their home.

To meet this growing demand for greener heating solutions, Grant has carried out extensive research and development to design, manufacture and supply a comprehensive range of renewable heating technologies. Grant's renewable product portfolio consists of the heat sources and complementary products including a growing range of heat emitters. Not only can installers turn to Grant for a complete range of products but their customers benefit from the peace of mind that comes from sourcing their heating system from one manufacturer.

Grant's renewable technologies all achieve impressive individual efficiencies however, when multiple technologies are combined, the overall efficiency of the complete heating system can be further improved. For example, installing an air source heat pump alongside a high performance cylinder and effective heat emitters can take a home's heating system into a new class of efficiency. All of Grant's products have been developed to complement one another, allowing each product to work at its best when installed alongside the other components within the system helping it to achieve maximum overall efficiency.

Alongside its comprehensive product offering, Grant also provides customer support in the form of design assistance and quotations. The dedicated Grant Renewables Support Team is on hand to assist with the design and sizing requirements for renewable and underfloor heating installations. From answering design queries and assisting with heat loss calculations through to providing full system drawings and complete product specifications, the Renewables Support Team can provide expert advice to help installers and their customers make informed decisions when choosing the right heating solutions for their requirements.

Through its design and quotation services and product supply, Grant delivers complete home heating packages and with so many different products available within its portfolio, there is a package solution to meet almost any home's heating requirements. The diverse range of products available from Grant delivers choice and flexibility for customers, allowing them to select the technologies which best meet their heating needs. From new builds through to retrofits and renovations, Grant's heating products are suitable for installation within a wide range of properties.

**For multiple package solutions, choose Grant.**



## Introducing the Products



### Aerona<sup>3</sup> R32 Air Source Heat Pumps

The Aerona<sup>3</sup> inverter driven air source heat pumps utilise the more environmentally friendly R32 refrigerant and have exceptional SCOPs (Seasonal Coefficients of Performance), delivering high performance while also having minimal impact on their surrounds both aesthetically and acoustically.



### VortexAir Hybrid

Cleverly combining an air source heat pump with a low NOx oil-fired boiler, the VortexAir hybrid allows homeowners to enjoy the best of both worlds, introducing the benefits of renewable energy with the back-up heating provided via the traditional fuel source.



### QR Cylinders

The Quick Recovery cylinder range consists of single, twin coil and pre-plumbed variants which are all manufactured to the highest specification to help deliver maximum heat transfer and recovery for effective hot water heating.



### Uflex Underfloor Heating

Grant's wet underfloor heating range, which includes systems suitable for both new build and retrofit situations, effectively and evenly distributes heat into a room while also helping the heat source, such as an air source heat pump, to work at its optimal efficiency.



### Afinia Aluminium Radiators

The Afinia aluminium vertical and horizontal radiators have excellent thermal conductivity which makes them highly responsive and incredibly effective for both low and high temperature systems.



### Sahara Solar Thermal

Available in on-roof, in-roof and flat roof mounting options, Grant's Sahara solar thermal systems offer a clean, sustainable and cost effective low carbon alternative to providing homes with hot water.





# Case Study

## Project Overview

This four-bedroom semi-detached property in Wiltshire underwent a complete heating system upgrade as part of a wider renovation project. In addition to building a large extension off the side of the property, this home's heating system was also updated, swapping from a gas boiler to a renewable system with the installation of a Grant AERONA<sup>3</sup> air source heat pump.



## Why renewables

Having lived in the property for five years, the owners wanted the renovation project to not only deliver their forever home but to enable them as a family to live as sustainably as they could. To achieve this, they needed to improve the efficiency of their heating and change the heat source to a greener alternative. This was the reason why a Grant whole house renewable heating system was selected and installed.



## Products Installed

- AERONA<sup>3</sup> 13kW R32 Air Source Heat Pump
- High Performance 300L Cylinder
- Uflex Underfloor Heating System (throughout the downstairs of the new extension)
- Uflex MINI Underfloor Heating System (throughout the downstairs of the original property)
- Afinia Aluminium Radiators (throughout upstairs of the entire property)

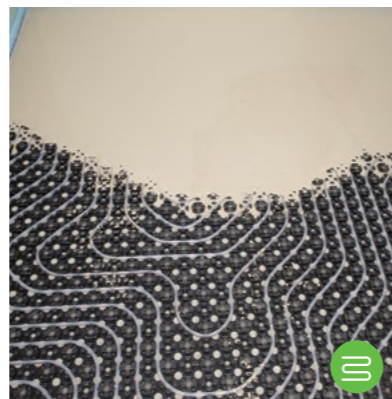
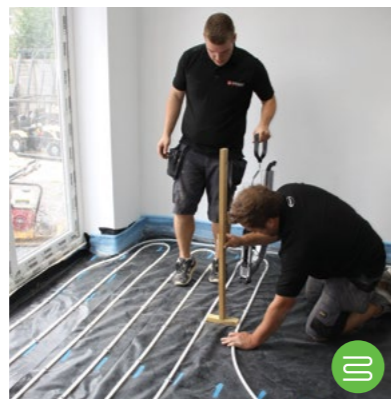
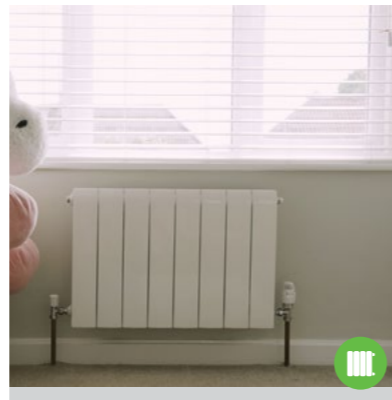

“The renovation project gave us the opportunity to completely transform our heating system, moving away from a fossil fuel and going green with a new heat pump. Our heating and hot water demand is now being efficiently fulfilled by an air source heat pump which is working effectively alongside the complementary technologies also supplied from Grant UK. Today, we have complete peace of mind that our renewable heating system is reliable and environmentally friendly and will be for many years to come.

The Homeowner

YouTube

## Green Benefits

The installation of an AERONA<sup>3</sup> R32 air source heat pump has significantly reduced the carbon footprint of the property as well as helping to lower the household energy bills. Furthermore, the installation is eligible for the Government's Domestic Renewable Heat Incentive. Through the RHI, this Grant heat pump will earn the homeowners regular payments over seven years, delivering financial rewards for sustainable, low carbon heating.





# Aerona<sup>3</sup> R32 Air Source Heat Pumps

The Aerona<sup>3</sup> R32 inverter driven air source heat pumps are Grant's greenest and most efficient heat pumps yet. Incorporating R32 refrigerant which has a significantly lower Global Warming Potential compared to traditional refrigerants, the Aerona<sup>3</sup> R32 range models are cleaner and more eco-friendly while also being incredibly effective. With excellent SCOPs, all of the Aerona<sup>3</sup> heat pumps achieve high performances allowing homeowners to lower their dependency on fossil fuels.



HEAT PUMP PRODUCT  
OF THE YEAR



## Standing out from the crowd

### Designed with the installer in mind

Grant's Aeronas<sup>3</sup> air source heat pumps incorporate a number of features, as standard, which are all designed to make the installation quicker and easier for engineers. From its integrated HE pump through to the simplified electrics, the Aeronas<sup>3</sup> has been designed to save installers time when onsite fitting the heat pump, reducing the installation time for engineers and efficiently restoring a property's heating for homeowners.

### Straightforward to install

The Aeronas<sup>3</sup> can be used with a common S-plan system which minimises the number of alterations the installing engineer needs to make to the existing pipework. The simplified electrics, consisting of a 3-core cable for the wiring centre and a 2-core flex for the controller, also make for an uncomplicated installation. Furthermore, the Aeronas<sup>3</sup> incorporates a built-in HE pump which saves time and space. By not having to add an external pump, the engineer saves time on the pipework and the electrician saves time because there is no need to wire in an external pump.

### User-friendly for homeowners

The Aeronas<sup>3</sup> heat pumps are compatible with a property's existing control system for the majority of installations. This means that homeowners can continue to use their familiar controller if they prefer, thus reducing the time spent installing and handing over a new control system. This can offer greater peace of mind for the end-user who is able to manage their new Aeronas<sup>3</sup> heat pump with their original controller.

### Simple to service and maintain

The Aeronas<sup>3</sup> has front access with all of its major components conveniently located at the front of the heat pump unit which makes the maintenance of the product simple and easy. As with all of Grant's products, the Aeronas<sup>3</sup> heat pump has been developed to make life easier for both the installer and the service engineer. With its components made accessible, all of the Aeronas<sup>3</sup> models are straightforward to clean and maintain.

### Anti corrosive coating

Sea air can be damaging to air source heat pumps fitted in coastal areas. For this reason, Grant offer Blygold corrosion protection on the Aeronas<sup>3</sup> range to help preserve and maintain heat pumps installed in the vicinity of the sea.

### Connect & Notify

Both the Aeronas<sup>3</sup> 6kW (HPID6R32) and 10kW (HPID10R32) heat pumps are Connect and Notify approved which means they can be installed and connected to the Grid without prior approval from the DNO which makes their installation even more straightforward.







## Aeronas<sup>3</sup> R32 Range

Consisting of four single phase models – 6kW, 10kW, 13kW and 17kW – the Aeronas<sup>3</sup> R32 heat pumps provide heating and hot water for properties. Each unit operates at high efficiencies even when the external temperatures are low, making for a cost-effective renewable alternative to traditional off-gas heating methods. Furthermore, the Aeronas<sup>3</sup> heat pumps have minimal impact on their surroundings being compact in size and quiet in operation with both the 13kW and 17kW models being awarded the Quiet Mark. The range is also Keymark approved.

### Models

HPID6R32	Aeronas <sup>3</sup> 6kW R32 Air Source Heat Pump
HPID10R32	Aeronas <sup>3</sup> 10kW R32 Air Source Heat Pump
HPID13R32	Aeronas <sup>3</sup> 13kW R32 Air Source Heat Pump
HPID17R32	Aeronas <sup>3</sup> 17kW R32 Air Source Heat Pump

### Features

-  Single phase with outputs from 6kW up to 17kW
-  Global Warming Potential of 675 (70% less than R410A refrigerant)
-  DC inverter driven
-  In-built weather compensation
-  In-built frost protection
-  Suitable for use with S & W-Plan heating control systems

### Included as standard

- Factory fitted HE circulating pump
- Flexi hoses
- Isolation valves
- Condensate drain elbow
- Remote controller and 8m cable
- Interface relay box

These components are all included within the price of the heat pump, delivering cost benefits for both the installer and their customers.



\*When installed by a G1 Installer. Subject to full T&C's.



## Performance & Noise Levels

### Seasonal Coefficient of Performance (SCOP)

The SCOP is the overall performance of the heat pump when used in a designated heating season (warm, average or cold), calculated as the reference annual heating demand divided by the annual energy consumed. For the UK, it is predominantly split into two heating seasons: warm for the south (diagonal line from north Wales to the Kent coast) and average for the rest of the UK mainland, including the Scottish islands of Orkney and Shetland.

It is important to note that as the outside air gets colder, the output and therefore the SCOP of an air source heat pump falls slightly, due to the reduced amount of heat energy available from the air. Conversely, when outside air temperature gets warmer, the output and COP will increase. By using SCOP as opposed to COP, these peaks and troughs are evened out into a realistic annual coefficient.

For example, the Grant Aeronas<sup>3</sup> HPID6R32 model produces 6kW at a SCOP of over 4 when tested at low temperature and average climate conditions. This means, for every kilowatt (kW) of energy used to run the Aeronas<sup>3</sup>, over 4kW of energy is being given to the heating system in return.

The overriding factor of the Aeronas<sup>3</sup> heat pump is that the output will modulate down or up depending on the climate conditions and the demand on the heating system, giving you peace of mind that you are as energy efficient as you can possibly be on every day of the year.

### Noise Levels

It is a common belief that air source heat pumps can be noisy when running. While the fans in a heat pump do make a sound as they rotate, Grant's air source heat pumps have been specifically designed to be quiet in operation to ensure there is little impact to the household and neighbouring properties.

The diagram on the right shows the sound levels of Grant's Aeronas<sup>3</sup> heat pumps compared with other common household appliances and noises.

The low operating sound levels enable Aeronas<sup>3</sup> models to easily integrate into outdoor environments, including those where noise restrictions may be in place. Their quiet operation has been acknowledged by Quiet Mark, an international award programme that validates and

awards low-noise, high performance technologies. Both the 13kW and 17kW Aeronas<sup>3</sup> heat pumps have been awarded the Quiet Mark, recognising these products for their excellent performances and identifying them as being amongst the quietest models within their given category.

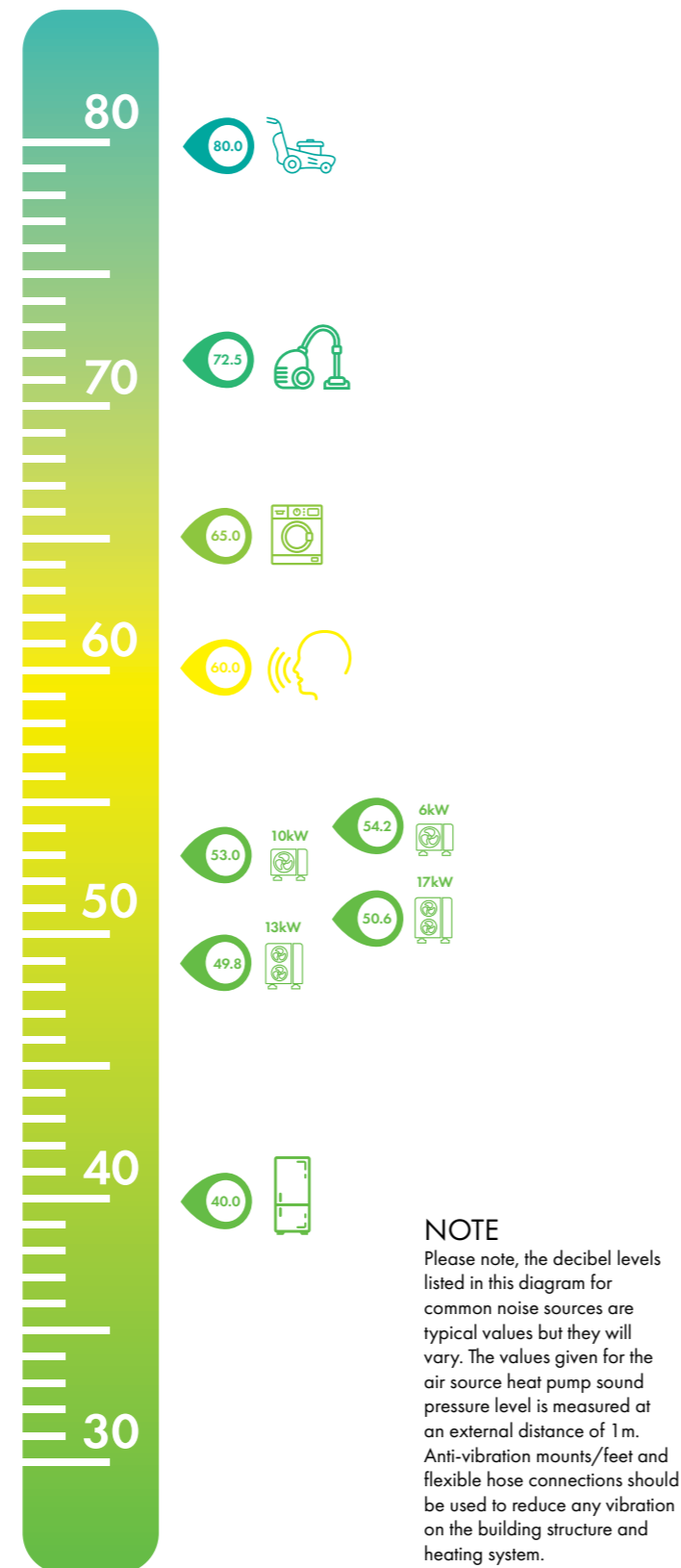

#### NOTE

Please note, the decibel levels listed in this diagram for common noise sources are typical values but they will vary. The values given for the air source heat pump sound pressure level is measured at an external distance of 1m. Anti-vibration mounts/feet and flexible hose connections should be used to reduce any vibration on the building structure and heating system.

## Noise levels

### How quiet is a heat pump?

Our new short video features audio footage from an Aeronas<sup>3</sup> 13kW air source heat pump and compares this with other common household appliances. Scan the QR code below to watch the video or head to our YouTube channel [youtube.com/myGrantUK](https://www.youtube.com/myGrantUK).

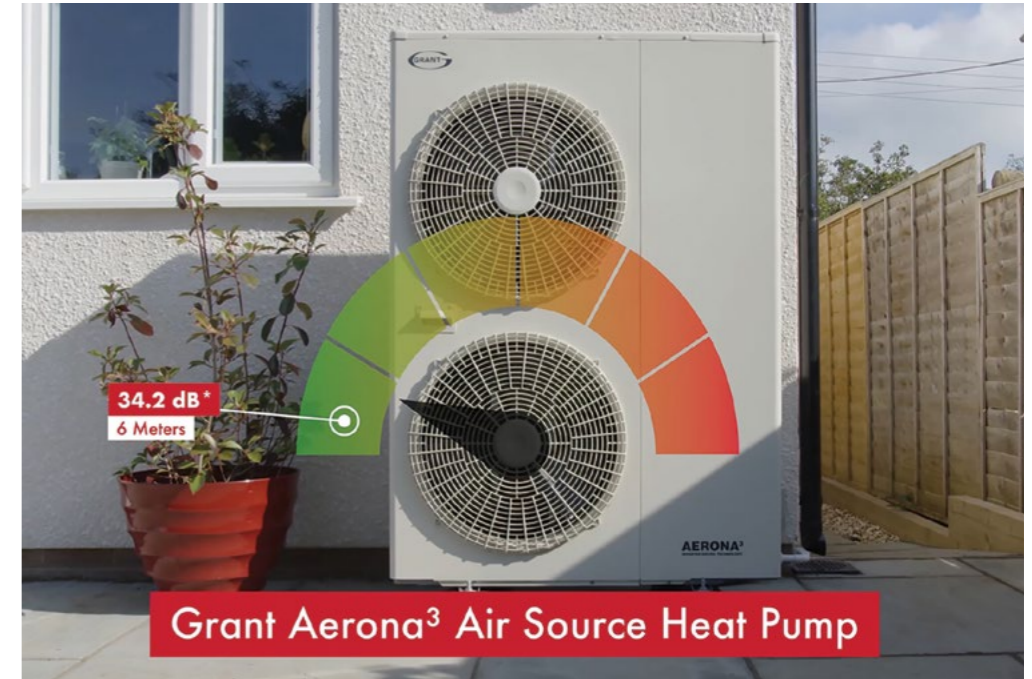

### Aeronas<sup>3</sup> Installation Packs

To make life a little easier for the installer, Grant offer installation packs which consist of all the essential components required to install an Aeronas<sup>3</sup> air source heat pump. Each pack is designed to simplify ordering while also delivering cost savings as well.

HPIDR32PACKA	HPIDR32PACKB	HPIDR32PACK3
<b>S-Plan for non pre-plumbed cylinders</b>	<b>S-Plan for Grant pre-plumbed cylinders</b>	<b>Direct for non pre-plumbed cylinders</b>
Combined volumiser/ low loss header	Combined volumiser/ low loss header	Combined volumiser/ low loss header
DHW programmer	DHW programmer	DHW programmer
Flexi foot kit	Flexi foot kit	Flexi foot kit
Mag One filter	Mag One filter	Mag One filter
18 litre sealed system kit	18 litre sealed system kit	18 litre sealed system kit
32A AC isolator	32A AC isolator	32A AC isolator
7 day immersion programmer (legionella)		7 day immersion programmer (legionella)
Wiring centre c/w DHW priority (EP001)		Heat pump wiring interface (EP002)
		Hot water priority relay
		28mm 3-port diverter valve
		Cylinder sensor



For more information on these packs please scan the QR code or go to [www.grantuk.com/products](https://www.grantuk.com/products)



# VortexAir Hybrid

The Grant VortexAir Hybrid couples together a Grant Vortex condensing low NOx oil-fired boiler with an Aeron3 air source heat pump. The VortexAir Hybrid cleverly combines a traditional fossil fuel source with the green advantage of a heat pump, providing a renewable solution to boiler replacements.

Using just a single flow and return connection into the house, the VortexAir Hybrid incorporates a 17kW Aeron3 R32 air source heat pump with a 15/26kW low NOx Vortex oil boiler. This unique arrangement allows the oil boiler to be installed first as a stand-alone unit, either internally or externally, replacing an older oil-fired appliance and providing immediate heat and hot water for the householder.

The heat pump is then installed externally and coupled via a simple plumbing and electrical arrangement to the oil boiler. The heat pump can be installed at the same time as the boiler or it can be fitted as part of a two-stage installation which is hugely beneficial in distress purchase situations. When a quick replacement heating solution is required, the VortexAir enables householders to rapidly restore their home heating with the boiler and then later incorporate an alternative fuel source with the heat pump element.

The Grant Vortex oil boiler utilised within the hybrid is renowned for its high efficiency, reliability and ultra low NOx emissions. This cleaner oil-fired boiler technology combined with the green credentials of the Aeron3 heat pump results in an innovative hybrid solution which delivers the best of both worlds. Homeowners can introduce renewable technology into their home while also having the peace of mind that comes with the back-up heating provided via the boiler.

## Models

HPIDAIR1526 VortexAir15-26kW Oil Boiler & 17kW R32 Heat Pump Hybrid

## Features

- Easy to install and maintain
- Boiler works as a stand-alone unit and can be installed internally or externally
- Heat pump is always fitted externally
- Boiler can be used to provide heat before the ASHP is fitted
- Meter ready, fully pre-plumbed and wired
- Option to manually switch between hybrid and oil
- Low level balanced flue supplied as standard
- Optional plume diverter kit available (purchase separately)



\*When installed by a G1 Installer. Subject to full T&C's.

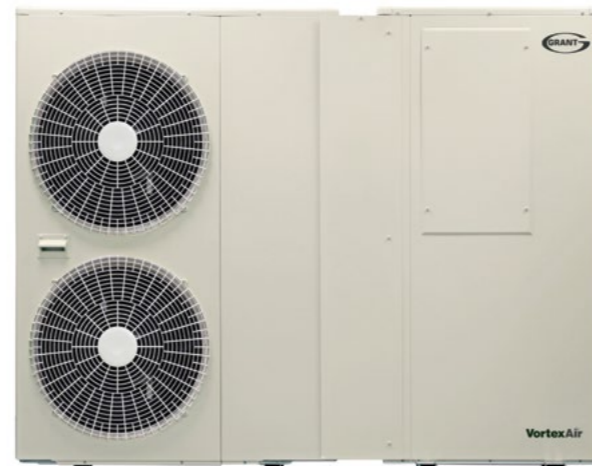

# Maximise System Efficiency

The Grant VortexAir Hybrid has been designed to maximise overall system efficiency with the use of an advanced control system. Automatically monitoring the ambient air temperature, the unit will seamlessly switch to the most effective heating mode, whether that be heat pump, oil, or a combination of both.

There are four unique operating modes incorporated into the Grant VortexAir's controller (detailed right). Working in this way, the heat pump is able to contribute to the heat requirement of the house for longer, thereby reducing running costs.

The graph below shows an example of how the operating modes seamlessly change depending upon the ambient air temperature and assumed heat loss for the property.

**MODE 1**  
Heat Pump only at lower flow temperatures between 35°C - 55°C for space heating (DHW fixed at 55°C)

**MODE 2**  
Heat Pump and Oil Boiler combined at lower flow temperatures between 40°C - 50°C

**MODE 3**  
Heat Pump and Oil Boiler combined at higher flow temperatures up to 70°C

**MODE 4**  
Oil Boiler with higher flow temperatures up to 70°C and little heat pump contribution

## Example of operating modes for a property with a 18kW assumed heat loss

Ambient Design Temp -5°C  
Flow Temp 45°C  
Radiator Design Temp 70°C

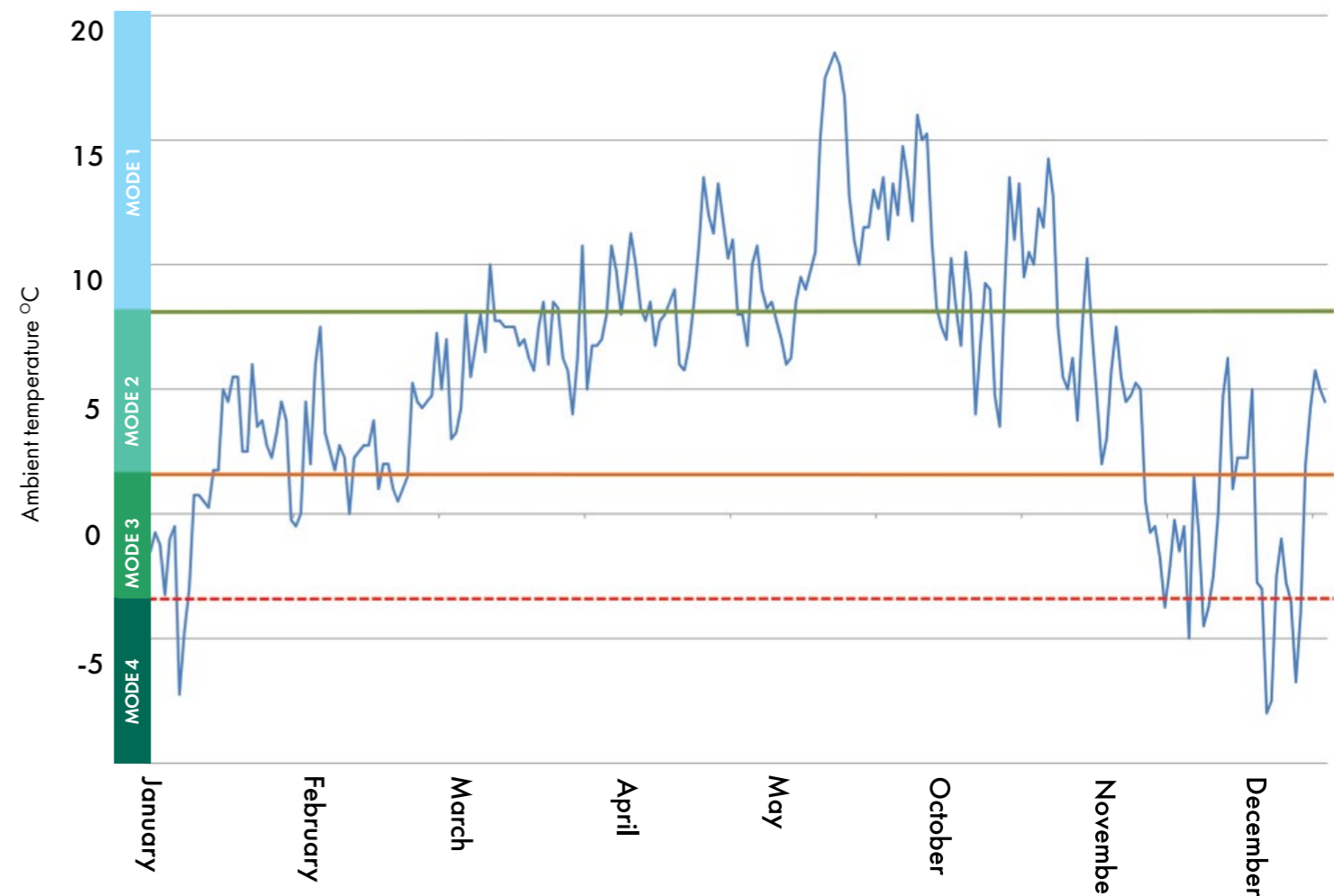



## Accessories

To accompany both the Aerona<sup>3</sup> and VortexAir Hybrid, Grant supply a range of heat pump accessories compatible with all of the models. These accessories are available to purchase individually and some are available as part of a heat pump pack.

### Sealed system kits

Sealed system kits are available to suit all Aerona<sup>3</sup> heat pump models and they are available in three sizes: 12ltr, 18ltr and 50ltr.

Part codes: HPAWSSK12 / HPAWSSK18 / HPAWSSK50

### Flexi-foot kit with fixings

Supplied in a pack comprised of two 600mm feet for mounting the Aerona<sup>3</sup>, the flexi-foot kit serves as anti-vibration as well raising the heat pump off the ground. When using these with a VortexAir Hybrid when both the boiler and heat pump are sited together externally, two kits will be required totalling four feet.

Part code: HPIDFOOT/KIT2

### Through wall insulation kit

This kit is a heavy duty 22-28mm flexi hose specifically designed for the Aerona<sup>3</sup>.

Part code: HPIDINSU/KIT

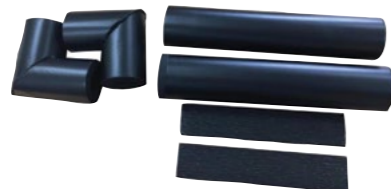

### Hot Water Priority Relay

This relay gives hot water priority within the central heating system. When the hot water boost is turned on as a result of needing hot water served within the home, the Grant Water Priority Relay will close the valve to the heating system. This allows the cylinder to fill with hot water without taking hot water from the heating system, satisfying the demands for both hot water and heating simultaneously.

Part code: HPWPR1

When a system has two central heating zones, Grant's Aerona<sup>3</sup> two zone Hot Water Priority Relay should be installed.

Part code: HPWR2

### Combined Low Loss Header/Volumiser

The Grant low loss header/Volumiser combines the benefits of creating hydraulic separation therefore maintaining the correct flow rate through the heat pump while providing a suitable volume of system water that allows the heat pump to fully modulate. The header comes complete with a 3kW supplementary heating element and relay.

Part code: HPIDSYSLHKIT



### External Volumiser

Designed for use where there is simply no room to fit the low loss header/volumiser inside the house, the external volumiser sits behind the heat pump. Connected to the flow from the heat pump into the flow of the system, the volumiser comes complete with a 3kW supplementary heater and relay. While this does not have the capability of providing any hydraulic separation, it does provide a minimum volume of water that allows the heat pump to control its modulation.

Part Code: HPIDVOL30EXT



See page 54 for a full list of Aerona<sup>3</sup> accessories.

## ERP & Hot Water Packages

Under the ErP Directive, when additional heating technologies are installed alongside an air source heat pump, a 'package label' is required which details the overall system efficiency rating.

By combining additional technologies, such as solar thermal and controls, the overall package efficiency can be improved. Each product effectively adds an efficiency percentage to the heat pump's seasonal space ErP rating, increasing the efficiency of the complete heating system with each product complementing one another in working operation.

For example, installing an Aerona<sup>3</sup> R32 air source heat pump with a Grant QR 200 litre cylinder and Sahara two collector Solar Thermal system would achieve a combined package efficiency of A+++.

Read more about Grant's cylinders on page 20.

Read more about Grant's Solar Thermal Systems on page 28.

Please note, if a heat pump is installed with a hot water cylinder only, a 'package label' is not required because the Directive does not classify this combination of products as a 'package'.

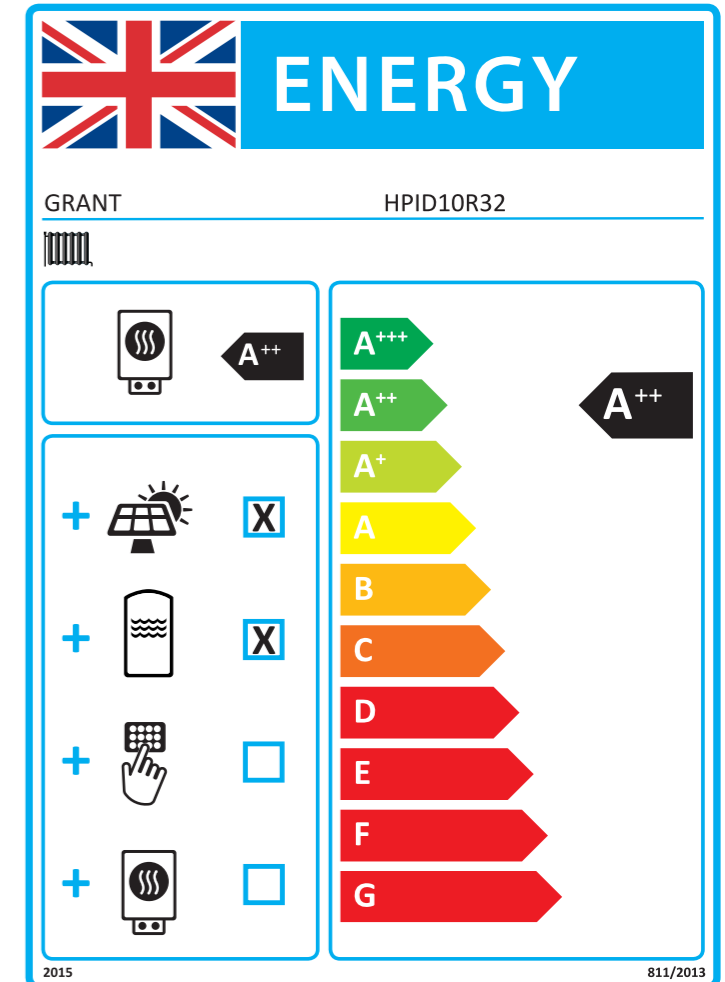

Example ErP package label





# Aerona<sup>3</sup> R32 Range Technical Specifications

		HPID6R32	HPID10R32	HPID13R32	HPID17R32
ErP Rating*	Heating	A+++	A+++	A+++	A+++
Height (mm)		675	882	1418	1418
Width (mm)		898	874	1024	1024
Depth (mm)		379.4	405	403	403
Weight (kg)	Empty	51	70	99	118
	Full	52.8	71.8	101	120
Heating capacity (kW) (BS EN 14511 - air 7°C/ Water 35°C)		6.92	11.1	13.6	18.0
Power input (kW) (BS EN 14511 - air 7°C/ Water 35°C)		1.41	2.10	2.59	3.76
COP (BS EN 14511 - air 7°C/ Water 35°C)		4.91	5.28	5.25	4.79
SCOP average climate conditions (BS EN 14511 - air 7°C/ Water 35°)		4.61	5.20	5.40	4.54
Refrigerant (R32) (kg)		0.80	1.55	2.20	2.80
Power supply		~230V 1ph 50Hz			
Water connections (BSPF)		¾"	1"	1 ¼"	1 ¼"
Min/ Max operating temperatures Air (°C)		-20/43	-20/43	-20/43	-20/43
Sound power level dB(A) (BS EN ISO 3743-1:2010)		65.2	64	60.8	61.6
Sound pressure level at 1 m - external (dB(A)) (Q=1)		54.2	53	49.8	50.6
<b>Electrical Installation Requirements</b>					
Max running current (A)		11.2	17.5	23.0	25.3
MCB	Rating (A)	16	20	32	32
	Type	C	C	C	C

\* Low temperature: 35°C flow (heating). From September 2019. EN14825: SSHEE W45.

HPID6R32

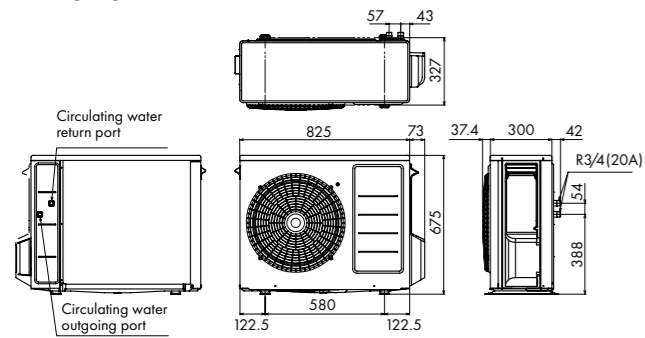

HPID10R32

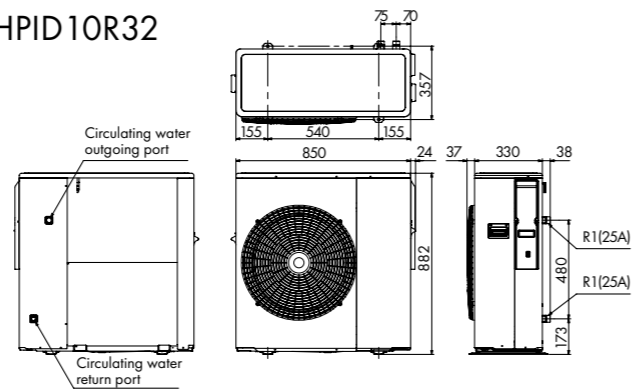

HPID13R32 & HPID17R32

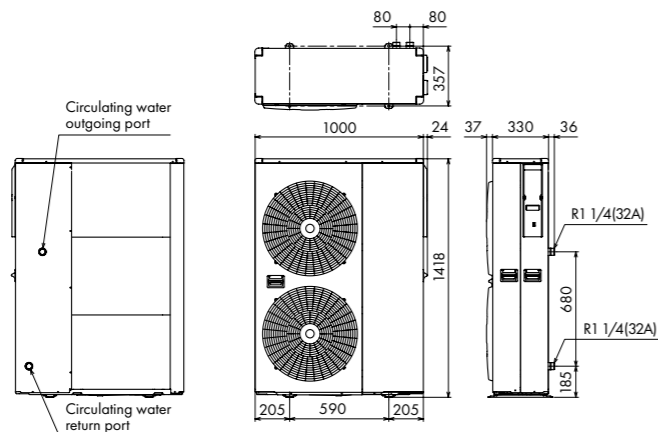

# VortexAir Hybrid Technical Specifications

		HPIDAIR1526
ErP Rating*	Heat Pump	A+++
	Boiler	A
Height (mm)		1420
Width (mm)		2047
Depth (mm)		525
Weight (kg)	Heat Pump	118
	Boiler	151
	Combined	269
Boiler output (kW)		21-26
Heat pump capacity (kW) (BS EN 14511 - air 7°C/ Water 35°C)		18.0
Heat pump power input (kW) (BS EN 14511 - air 7°C/ Water 35°C)		3.76
Heat pump COP (BS EN 14511 - air 7°C/ Water 35°C)		4.79
Heat pump SCOP average climate conditions (BS EN 14511 - air 7°C/ Water 35°)		4.54
Heat pump Refrigerant (R32) (kg)		2.80
Heat pump power supply		~230V 1ph 50Hz
Heat pump water connections (BSPF)		1 ¼"
Heat pump min/ max operating temperatures Air (°C)		-20/43
Heat pump sound power level dB(A) (BS EN ISO 3743-1:2010)		61.6
Heat pump sound pressure level at 1 m - external (dB(A)) (Q=1)		50.6
<b>Electrical Installation Requirements</b>		
Heat pump max running current (A)		25.3
MCB	Rating (A)	32
	Type	C

\* Low temperature: 35°C flow (heating). From September 2019. EN14825: SSHEE W45.

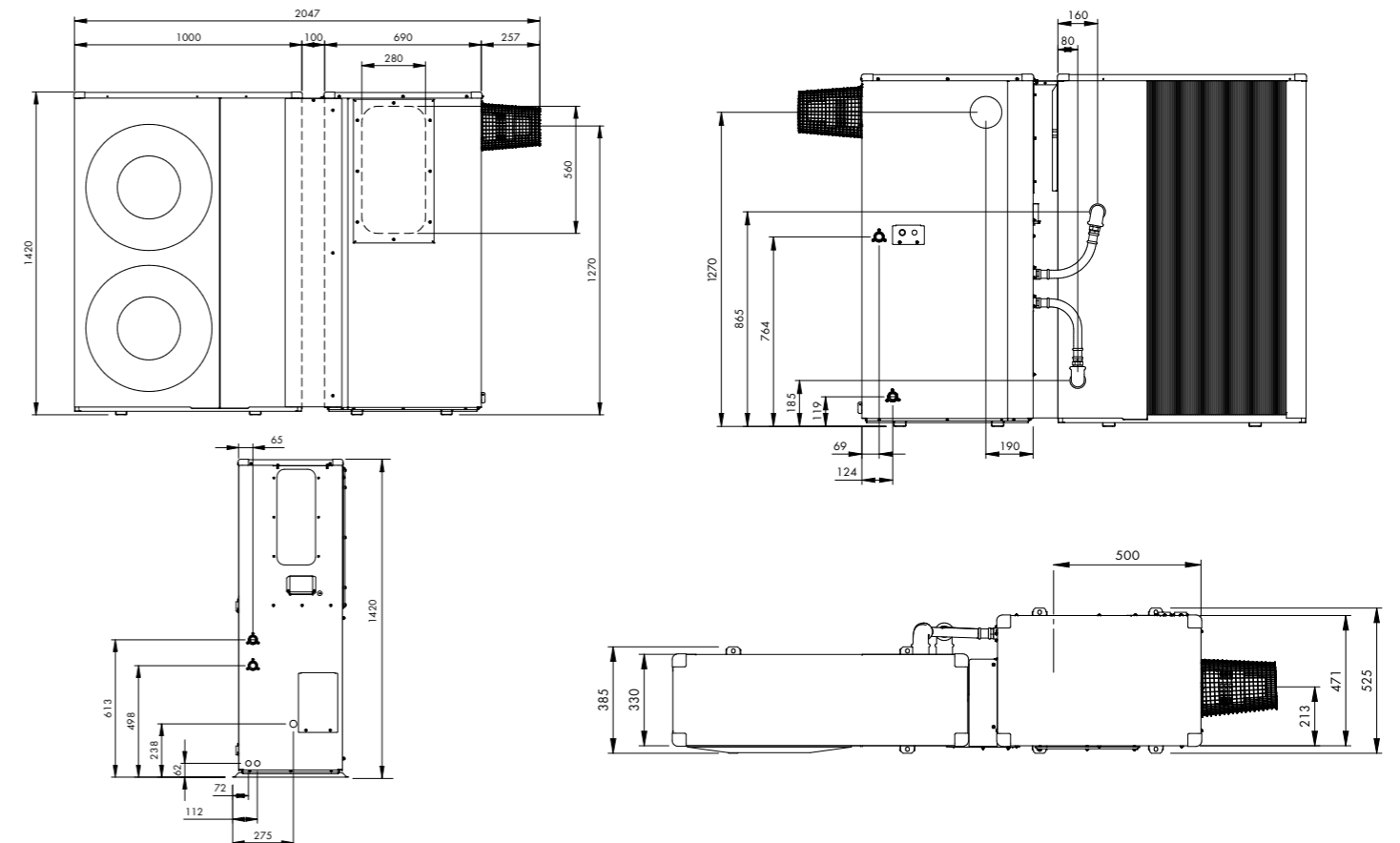





## Quick Recovery Hot Water Storage Cylinders

The Quick Recovery (QR) cylinder range comprises of high efficiency indirect hot water solutions which can partner with all of Grant's heat source appliances. Each model can complement traditional and renewable technologies, providing an eco-friendly, reliable and energy efficient solution for a home's hot water requirements. All of the QR cylinder models are suitable for use as unvented or open vented cylinders, and are designed to suit multiple installation scenarios, making them Grant's most versatile range of hot water cylinders.





# Introduction to the QR Range

## Universal Compatibility

All of the QR cylinders are suitable for installation alongside boilers, air source heat pumps and solar thermal systems. This means they can be fitted as part of a package with either a Vortex and VortexBlue oil boiler, an Aerona<sup>3</sup> air source heat pump or a Grant Solar Thermal System. When an installation involves more than one heat source, such as a heat pump and solar thermal system, both systems can be combined using one of the twin coil QR cylinder models. The streamlined QR cylinder range is, therefore, incredibly adaptable with each model being suitable for multiple applications which can make specification very straightforward.

## Excellent Performance

The QR cylinder range is Grant's most efficient generation of cylinder models, boasting our fastest heat-up times and improved standing heat losses.

## Clever Design

Each QR cylinder incorporates a number of design features which make for an easier installation. The connections are all compression fittings and the pre-plumbed models include a fully integrated wiring centre. A plinth is also available as an optional accessory within the range – this plinth (which is suitable for installation with all the QR cylinders, excluding the Integrated model) allows the pipework to be plumbed in the floor and then the cylinder can be mounted on top with just elbows required to pipe the unit up, making for a tidy installation finish. With these features and the cylinders' streamlined design, the QR range successfully combines function and aesthetics.

## Quality build

The QR cylinder range is produced to the highest standards so that each model delivers maximum heat transfer and recovery. They are manufactured using a high quality duplex stainless steel inner shell and the large internal coils are made from 22mm stainless steel tubing. Each cylinder is also insulated with 50mm of CFC/HCFC free, fire retardant, polyurethane foam which is injected between the stainless steel cylinder and the galvanised outer casing. This high level of insulation ensures low standing heat losses and outstanding efficiency. All of the cylinders within the QR range have a 25 year guarantee on their shell, reflecting their exceptional build quality and providing ultimate peace of mind.

## Features

- 25 year material guarantee on cylinder shell (subject to full Terms and Conditions)
- 22mm stainless steel compression bosses supplied with polypropylene caps for protection during transit (Pre-plumbed and Integrated Cylinders have 28mm compression fittings supplied in the kit)
- No anode required
- Factory-fitted 3kW immersion heater
- Fast recovery stainless steel coils
- Labelled tappings and connections
- Factory fitted temperature and pressure relief valve
- Supplied with unvented kit as standard including expansion vessel, inlet manifold, tundish, 2-port motorised valve and dual thermostat
- Quality external finish with organic Estectic Tex paint
- Global Warming Potential (GWP) of 3.1
- Ozone Depletion Potential (ODP) of 0



\*subject to full T&C's

# QR Models

The Quick Recovery unvented, indirect mains pressure cylinders are available in single coil and twin coil variants. Available in sizes from 150 litres up to 300 litres, the QR cylinders are high performing units which provide homes with an efficient, reliable hot water storage solution. The range includes pre-plumbed models which make for a quicker and easier installation as well as slimline units which are ideally suited for properties where space is at a premium. Internal and external volumisers are also available to complement the QR cylinder range.

## Models - Nominal Volumes

### Single Coil

QRSC150	150 litres
QRSC180	180 litres
QRSC210	210 litres
QRSC250	250 litres
QRSC300	300 litres

### Single Coil | Slimline

QRSC150SL	150 litres
QRSC180SL	180 litres
QRSC210SL	210 litres

### Single Coil | Pre-Plumbed

QRSC210PP	210 litres
QRSC250PP	250 litres
QRSC300PP	300 litres

### Single Coil | Integrated

QRINTSC210	210 litres
------------	------------

### Twin Coil

QRTC210	210 litres
QRTC250	250 litres
QRTC300	300 litres

## Pre-Plumbed Models

The QR Pre-Plumbed cylinder models are supplied with the following:

Factory-fitted pre-wired controls including EP001 wiring centre, digital dual thermostat and immersion heat timer

Factory-fitted cold water inlet pipework

Potable water expansion vessel for the cylinder

Factory-fitted primary system pipework including a built-in filling loop, system pressure gauge, automatic system bypass, a 2-port zone valve for the hot water and two 2-port zone valves for two heating zones

Optional galvanised plinth

## Quick Recovery Integrated Cabinet Cylinder

The QR Integrated Cylinder is Grant UK's first cabinet cylinder model. This product encloses a QR Pre-Plumbed 210 litre single coil cylinder within a white casing which is suitable for kitchen and utility room installations. This innovative product, which has a similar footprint to that of a washing machine or fridge, has been designed with both the installer and homeowner in mind. The self-contained cabinet cylinder includes multiple factory-fitted features so installation is simple and straightforward. Meanwhile, the design of the unit allows for a cylinder to be easily integrated into a home, ideal when a separate airing cupboard or room is not available.

## Supplied as standard:

Both the heating system and hot water expansion vessels

Pressure gauge and filling loop

Digital dual thermostat and programmable immersion heater timer

Pre-wired electrics and factory-fitted pipework including a built-in filling loop, system pressure gauge, automatic system bypass, a 2-port zone valve for the hot water and two 2-port zone valves for two heating zones

Easy to access pipe connections and electrical cable outlets positioned at top of the unit towards the rear

Spacer channels provided to create a 100mm deep void between the rear of the cabinet and the wall to accommodate and conceal the pipework and electrical wiring, if required

Upper front panel is hinged and supported in the open position on two gas springs to allow access to control panel

Restraining chain fitted to the front panel to ease opening



# Quick Recovery Cylinder Range Technical Specifications

## Single Coil

Model	Actual Capacity (ltrs)	ErP Rating	Expansion vessel (ltrs)	Coil rating primary (kW)	Standing heat loss (kW/24hrs)	Overall Height (mm)	Overall Diameter (mm)	Weight empty (kg)	Weight full (kg)
QRSC150	136	C	19	32.0	1.41	1117	550	45	181
QRSC180	167	C	19	32.0	1.61	1305	550	50	217
QRSC210	197	C	19	32.0	1.79	1491	550	54	251
QRSC250	237	C	19	32.0	2.02	1744	550	62	299
QRSC300	289	C	24	34.0	2.24	2054	550	68	357

## Single Coil | Slimline

Model	Actual Capacity (ltrs)	ErP Rating	Expansion vessel (ltrs)	Coil rating primary (kW)	Standing heat loss (kW/24hrs)	Overall Height (mm)	Overall Diameter (mm)	Weight empty (kg)	Weight full (kg)
QRSC150SL	141	C	19	30.0	1.58	1458	478	39	180
QRSC180SL	171	C	19	30.0	1.72	1708	478	43	214
QRSC210SL	201	C	19	30.0	2.08	2021	478	50	251

## Single Coil | Pre Plumbed

Model	Actual Capacity (ltrs)	ErP Rating	Expansion vessel (ltrs)	Coil rating primary (kW)	Standing heat loss (kW/24hrs)	Overall Height (mm)	Overall Diameter (mm)	Weight empty (kg)	Weight full (kg)
QRSC210PP	197	C	19	32.0	1.79	1493	550	59	256
QRSC250PP	237	C	19	32.0	2.02	1744	550	67	304
QRSC300PP	289	C	24	34.0	2.24	2057	550	73	362

## Single Coil | Integrated

Model	Actual Capacity (ltrs)	ErP Rating	Expansion vessel (ltrs)	Coil rating primary (kW)	Standing heat loss (kW/24hrs)	Overall Height (mm)	Overall Width (mm)	Overall Depth (mm)	Weight empty (kg)	Weight full (kg)
QRINTSC210	197	C	19	32.0	1.79	1855	594	727*	139	375

## Twin Coil

Model	Actual Capacity (ltrs)	ErP Rating	Expansion vessel (ltrs)	Coil rating primary (kW)	Solar Coil (kW)	Standing heat loss (kW/24hrs)	Overall Height (mm)	Overall Diameter (mm)	Weight empty (kg)	Weight full (kg)
QRTC210	192	C	19	32.0	19.7	1.79	1490	550	59	251
QRTC250	233	C	19	32.0	20.7	2.02	1741	550	65	298
QRTC300	284	C	24	34.0	22.1	2.24	2054	550	77	361

\*includes 100mm spacer channel (627mm without spacer)

# Quick Recovery Cylinder Range Technical Specifications

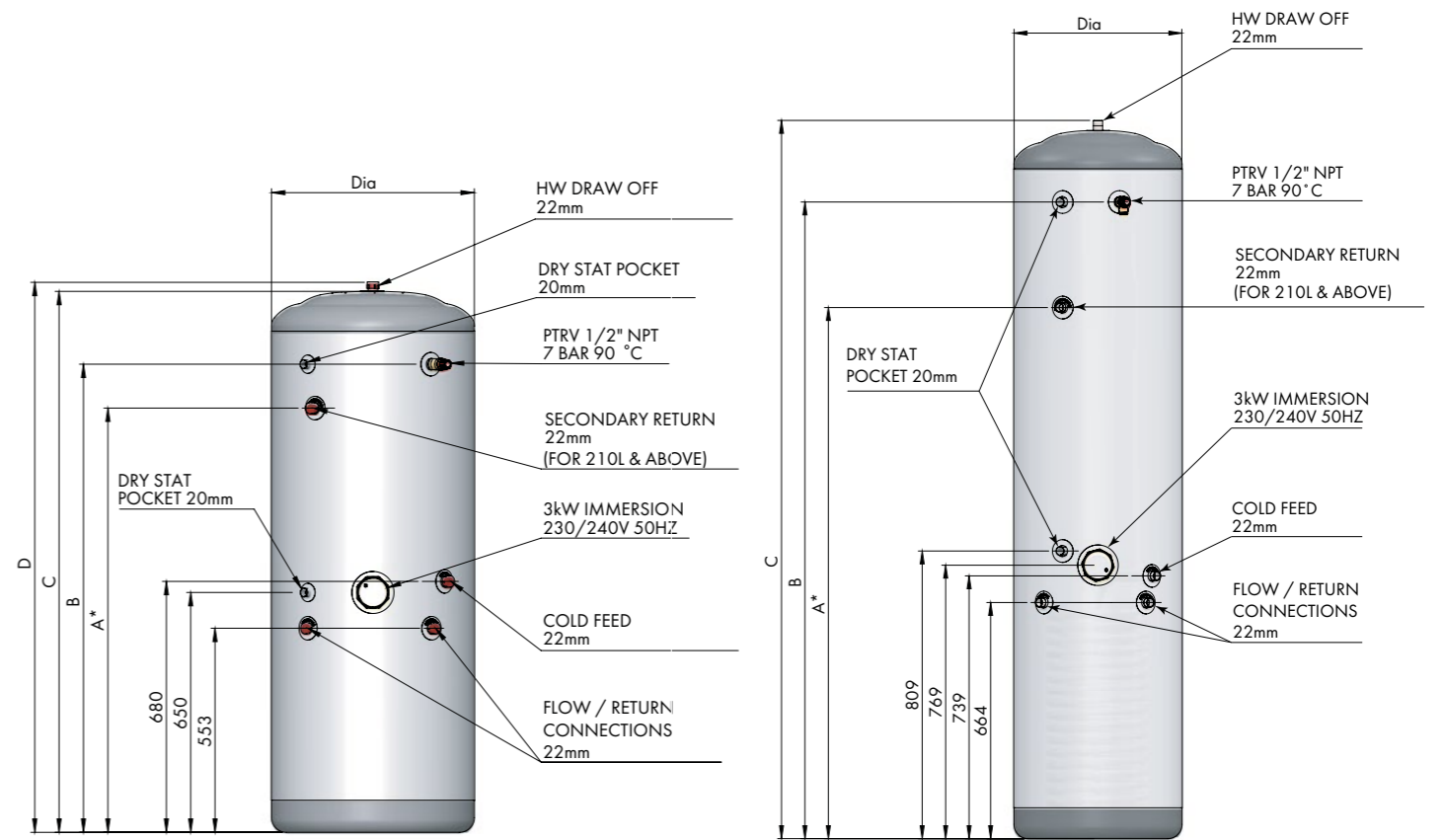

## Single Coil

Dimensions (mm)	150L	180L	210L	250L	300L
A*	-	-	1150	1400	1600
B	893	1081	1269	1519	1832
C	1091	1279	1467	1717	2030
D	1117	1305	1491	1744	2054
Diameter	550	550	550	550	550

\*Secondary return on 210, 250 & 300 litre models only

## Single Coil | Slimline

Dimensions (mm)	150L	180L	210L
A*	-	-	1494
B	1228	1478	1791
C	1458	1708	2021
Diameter	478	478	478

\*Secondary return on 210 litre model only



# Quick Recovery Cylinder Range Technical Specifications

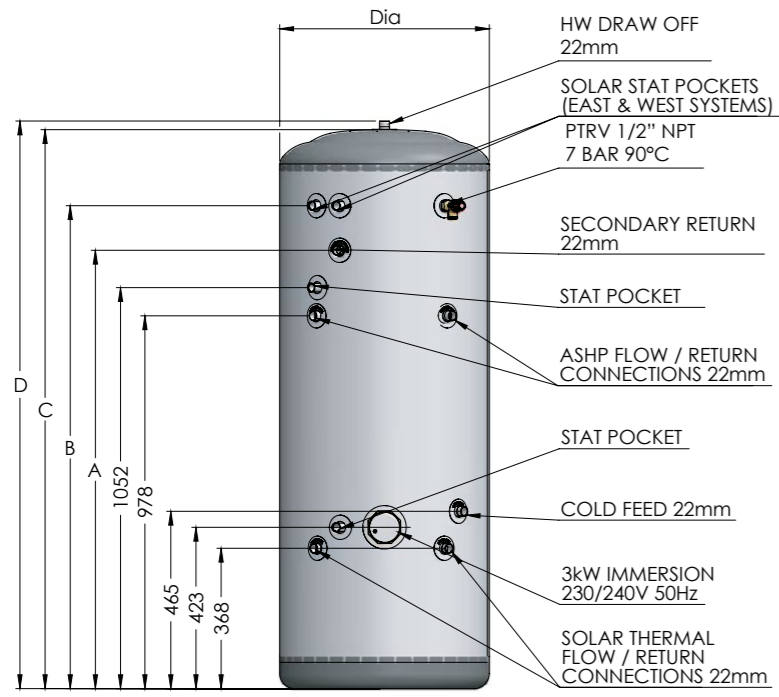

## Twin Coil

Dimensions (mm)	210L	250L	300L
A	1150	1401	1601
B	1267	1518	1831
C	1467	1717	2030
D	1490	1741	2054
Diameter	550	550	550

# Quick Recovery Cylinder Range Technical Specifications

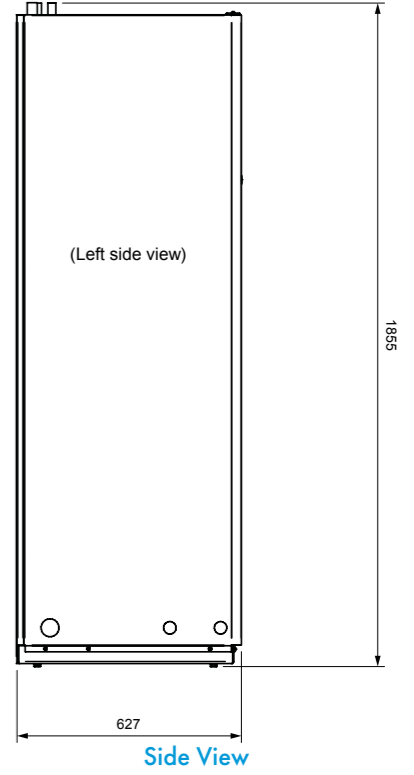
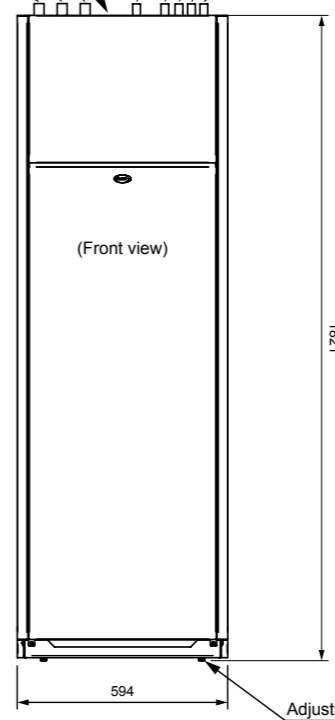
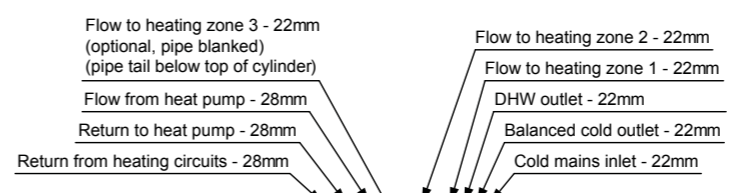

Front View

Side View

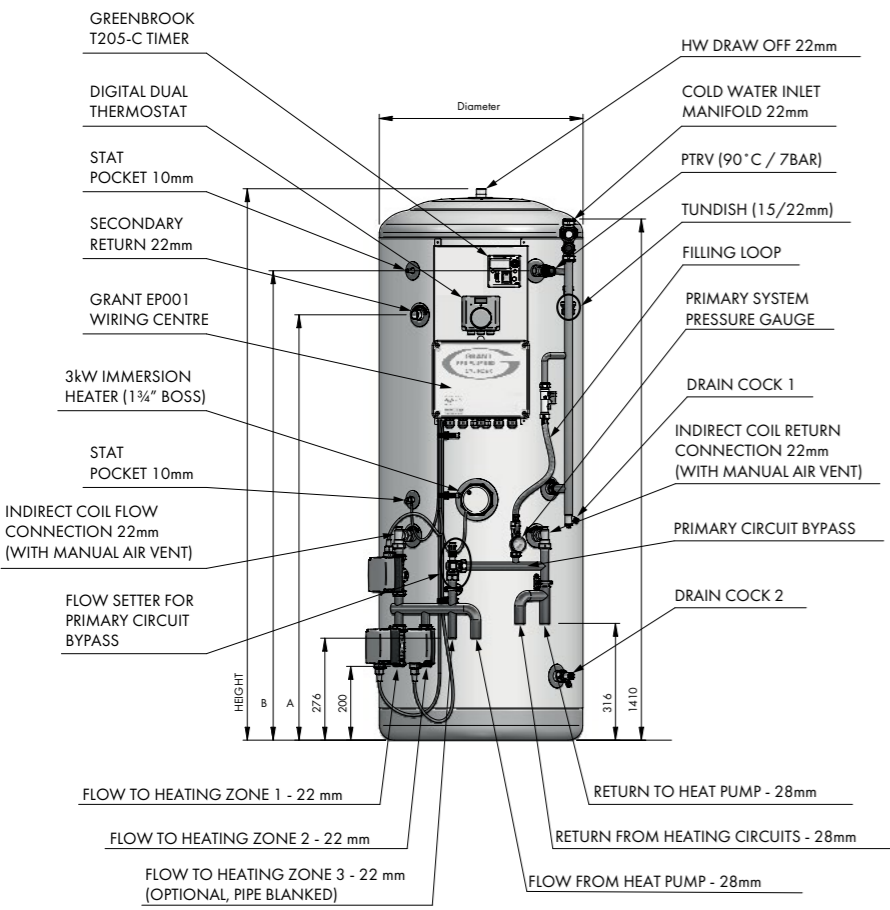

## Single Coil | Pre-Plumbed

Dimensions (mm)	210L	250L	300L
A	1150	1400	1600
B	1269	1519	1832
Height	1493	1744	2057
Diameter	550	550	550

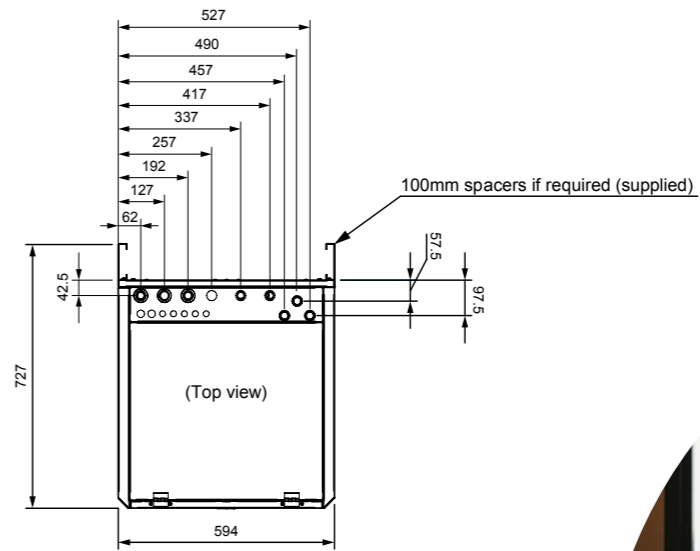

Top View

## Single Coil | Integrated





## Uflex Underfloor Heating Range

Grant's underfloor heating range consists of two systems – Uflex and Uflex MINI – both of which can be successfully used with a variety of heat sources, from traditional boilers through to renewable heating products such as air source heat pumps. When correctly designed and installed, underfloor heating will allow the heat source to work at its optimal efficiency. Homeowners can therefore not only benefit from the flexibility that this unobtrusive heat emitter offers, but they can also enjoy lower energy bills as a result of improving the overall efficiency of their heating system.





# Underfloor Heating by Grant

## Highly efficient

The warm water used in underfloor heating systems has a much lower flow temperature, compared to conventional radiator systems, as it feeds into a much larger surface area. This enables it to heat a room very effectively and efficiently.

Grant's underfloor systems operate at their most efficient when they are not frequently switched off and on. The floor screed takes time to heat up, but once up to temperature it only requires a small amount of energy to maintain this. Switching the system off and on, as is commonly the case with a radiator system, results in the floor losing temperature, requiring more heat input to reach that temperature when switched back on again, and so on.

Operating systems with a 'setback' (unoccupied) control, maintains the floor at a minimum temperature during these times and avoids the wasteful use of energy to reheat the floor from cold. With this type of control the normal room temperature can be achieved during periods of occupancy, but during other periods the 'setback' control automatically drops the room temperature to a lower level. This keeps the floor warm and reduces the heat-up time when the control switches back to provide normal room temperature again.

Over time, 'setback' control will reduce the overall demand on the heat source, increasing system efficiency and lowering running costs.

## Optimal control and comfort

When designing an underfloor heating system, the pipework layout can be easily divided into zones. With both Uflex and Uflex MINI, rooms can either be

split into more than one zone or multiple rooms can be incorporated into one zone. This allows homeowners to precisely control the temperature in a particular room or a space within a room. The temperature delivered is also evenly distributed from one side of the room to the other. The pipework is positioned so that the entire room will receive heat with no 'hotspots' or cool draughts. Underfloor systems radiate heat uniformly upwards, achieving a constant temperature throughout the space to deliver ultimate comfort.

## Quick & easy installation

Grant underfloor heating is supplied as packs specifically suited to meet the requirements detailed in the system designs. From the pipework and connections through to the edging strip and controls, Grant can supply all the components required. Straightforward to install and with the Uflex MINI system suitable to be fitted by a single engineer, Grant's underfloor range is user-friendly to work with and simple to maintain. Furthermore, Grant can be on hand with a full design service, providing installers with assistance from start to finish.

## Dedicated design team

Grant has a Renewables Team who are on hand to provide product and design assistance. This Team has extensive experience in a range of products including air source heat pumps, complementary technologies, and heat emitters such as underfloor. From product specification through to producing full designs, Grant can help installers develop bespoke package solutions to suit the heating needs of their customers.

## Quick quote turnaround

Specifying the required parts to complete an underfloor heating installation can be time-consuming so Grant are able to provide installers with comprehensive quotations, quickly and efficiently. Each quotation will detail the components required to complete the specific job being quoted for. These components can then be supplied as a pack once the order is finalised.

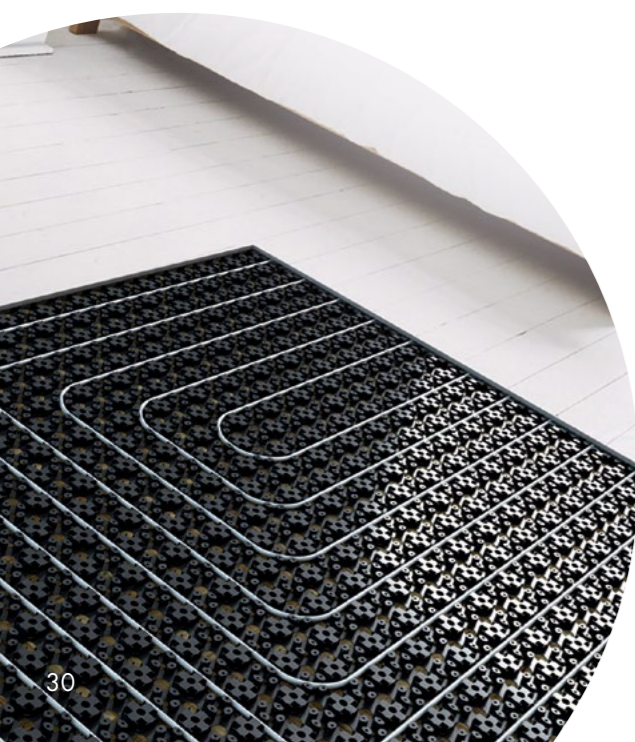

# Suitable Floor Coverings

When using underfloor heating it's important to consider the correct type of floor covering as not all types of finishes are suitable for use with this heat emitter. The objective of underfloor heating is to transfer heat from the system into the room and some floor coverings can restrict this movement of heat. Flooring materials such as tiles and some types of vinyl flooring are low resistance and are therefore ideal for underfloor. Meanwhile, thicker finishes such as certain types of wood and thin carpets have medium resistance which means that some of the heat is retained. Any carpets and underlay which have a combined tog of over 1.5 are not suitable for an underfloor heating system.

Tile, stone & polished screed	Vinyl flooring	Engineered timber & laminate flooring	Solid hard & soft wood	Carpet
✓ excellent heat transfer	✓ good heat transfer	✓ average heat transfer	✓ average heat transfer	x low heat transfer
✓ ideal for use with underfloor	✓ robust & hard wearing	✓ performs well with changes in temperature	x changes in temperature can cause warping	x carpet tog & underlay must not exceed 1.5
✓ can be heated to up to 29°C	✓ can be heated to up to 27°C	✓ can be heated to up to 27°C	x care should be taken when specifying board width & thickness	
	x not recommended for high heat loss areas such as conservatories			
Low resistance 0.01 - 0.05m <sup>2</sup> K/W		Medium resistance 0.05 - 0.1m <sup>2</sup> K/W		High resistance 0.1 - 0.15m <sup>2</sup> K/W

**IMPORTANT:** Always check with the flooring manufacturer to confirm compatibility. Check moisture content of any wood flooring and ensure real wood floor boards are climatized in the laying area for a minimum of one day prior to fitting.



# Uflex



Grant's Uflex underfloor heating system is embedded into the floor construction. It is ideally suited for new builds whereby the pipework is installed during the initial stages of the property's development. The Uflex pipework is then positioned and clipped into place once the flooring's insulation and membrane has been fitted, after which a sand/cement or flow screed is laid over the top and allowed to fully dry before heat is introduced.

With a drying time of up to thirty days, the Uflex underfloor system can be fitted as part of the floor construction process, therefore causing no delays in construction. Grant's Uflex system makes underfloor heating a viable option for a wide range of projects, from one-off new build projects and room extensions through to larger multi-property developments.

## Types of Pipe

Two types of pipe are available for installation as part of a Uflex underfloor heating system – PE-RT and PEX-AL-PEX. Both the PE-RT and PEX-AL-PEX pipe are 16mm in diameter and they are compatible with all of the Uflex system components. The two types of pipe are both flexible and easy to work with but the PEX-AL-PEX pipe, which retains its curved shape when bent into position, offers the additional benefit of being suitable for other general plumbing uses. Installers can therefore use the amount of PEX-AL-PEX pipe they need for the Uflex installation and then use the pipe elsewhere in the property's plumbing system, reducing wastage.

## Features

-  Screeded system
-  Unique edge insulation
-  Simple installation

## PEX-AL-PEX Pipe

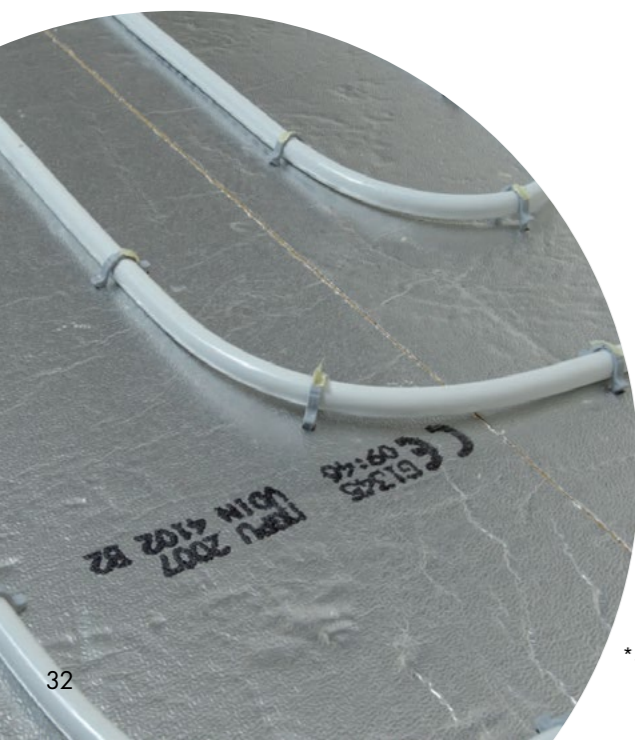
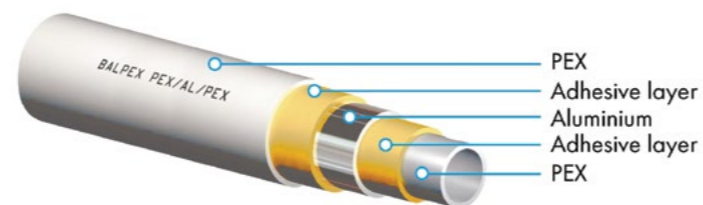

\*Subject to full T&C's

# Uflex MINI

The Uflex MINI system differs to Uflex in that it can be installed over any existing sound and level floor surface and is compatible with most types of floor covering. While it is suitable for new builds, Uflex MINI is specifically designed to suit retrofits and renovations, when an underfloor heating system is to be fitted in a property with a floor construction already in place. At just 15mm finished floor height, this underfloor system can be installed incredibly quickly and with minimal disruption to a property's existing floor and door arrangements.

Grant's Uflex MINI underfloor heating system consists of self-adhesive panels which are simply placed on top of the sealed floor. The pipework is then clipped into place without the need for staples before a self-levelling screed is laid over the top. The flexible, self-levelling screed used with the Uflex MINI system can be walked on the following day and dries within just three days enabling the heat source to be connected shortly after, restoring heat to a property within a minimal amount of time. With so many installation-friendly features, the Uflex MINI underfloor system can deliver ultimate comfort with minimal hassle.

## Features

-  Only 15mm finished floor height
-  Fully dry in just 3 days
-  Quick reaction time
-  Simple installation
-  No overboarding required
-  Suitable for ground floor and first floor installations



\*Subject to full T&C's

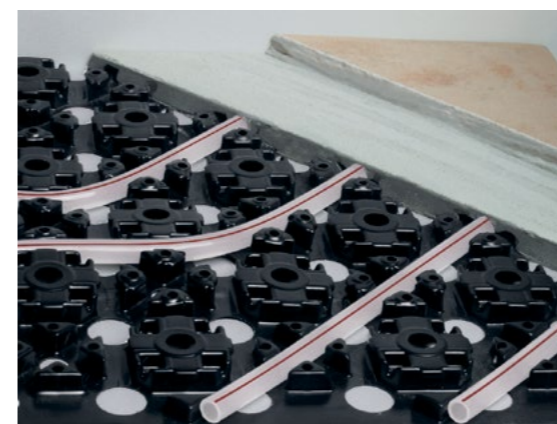

## COMING SOON Uflex Overlay System

AVAILABLE FROM SEPTEMBER 2022  
visit [www.grantuk.com](http://www.grantuk.com) for more details





## Intelligent Controls

Alongside the pipework and components, Grant also supply the control systems and wiring centres to operate both Uflex and Uflex MINI underfloor heating system installations.

Grant's underfloor heating controls range includes the Uflex Neostat V2 and Uflex Edge hard wired programmable room thermostats for use with the Uflex UH8 Wiring Centre, as well as the wireless NeoAir V2-M programmable room thermostat which pairs with the UH8-RF Wiring Centre. Straightforward to install, these controls combine intelligent operation with user-friendly navigation to give homeowners accurate control of their room temperatures and comfort levels.





## Controls

### Uflex Neostat V2

The Grant Uflex Neostat V2 is a hard-wired programmable room thermostat, operating as both a programmer and a room thermostat. The control allows homeowners to set when their heating will come on and off as well as sensing the air temperature so that when this falls below the thermostat setting, it will switch the heating on and, once the set temperature has been reached, it will switch the heating off again. Suitable for single and multi-zone installations, the Uflex Neostat V2 makes programming simple and straightforward.

### Uflex Edge

Similar to the Uflex Neostat V2, the Uflex Edge is also a hard-wired programmable room thermostat but it incorporates its own RF connection functionality to enable wireless connectivity with air temperature sensors. The Uflex Edge is designed to be paired with wireless air sensors located in different rooms or spaces within the home to provide greater temperature accuracy. When using multiple sensors, the thermostat can calculate the average temperature to effortlessly maintain desired room temperatures throughout the home and is ideally suited to larger open plan properties.

The Uflex Edge can also be paired to wireless window/door switches so that when a window or door is open, the heating is automatically switched to Standby Mode and when the window or door is closed, the unit will return the system to normal mode.

### Uflex NeoAir V2-M

The NeoAir V2-M is a wireless programmable room thermostat which is also compatible with both the Uflex and Uflex MINI underfloor heating systems. Battery powered, the NeoAir V2-M has wireless RF connectivity and it can either be used as a thermostat, a time clock or as both a thermostat and hot water timer. One remote sensor can be connected to the NeoAir V2-M which can either be used to monitor the floor temperature or to provide remote air temperature sensing. When paired to the NeoHub and neoApp, the NeoAir V2-M is compatible for use with single or multiple wireless air sensors making this wireless control ideally suited to large, open plan spaces when an average air temperature needs to be calculated.

### User friendly

The Uflex Neostat V2, Uflex Edge and NeoAir V2-M

each have a visual display that provides homeowners with the essential information they need to know about their system. Both the Uflex Neostat V2 and NeoAir V2-M are easy to navigate with all of the programming options available across the bottom of the back lit display and the Uflex Edge has an LCD display screen with the navigating buttons located to the side of the screen. Each of these programmable thermostats allow end-users to adjust their settings, view their room-by-room temperatures and to access troubleshooting assistance when required.

The neoApp is a supporting app that homeowners can use alongside the Uflex Neostat V2 and NeoAir V2-M programmable thermostats. When the Uflex Neostat V2 and NeoAir V2-M are paired to the neoHub via a WiFi connection, this will enable remote control of the device from anywhere via the neoHub app. Meanwhile, the Uflex Edge offers Modbus Connectivity which allows third party integrators the option to integrate the thermostat with home automation and building management systems.

All of the thermostats are slim and stylish with a glacier white finish, compact design, and their displays use a white back light which turns off automatically when not in use. Flexible programming is available with the Uflex Neostat V2, Uflex Edge and NeoAir V2-M each offering 5/2 Day programming, 7 Day programming and 24 Hours programming as well as holiday function. Each device also has a key locking function, which can help reduce tampering of the heating system.

### Self Learning Preheat functionality

Each thermostat can cleverly calculate the amount of time it takes for a home to warm up to the desired temperature. Using this Self Learning Preheat calculation, the Uflex Neostat V2, Uflex Edge and NeoAir V2-M can ensure a property is warm when the homeowners wake up and return home, automatically optimising this throughout the year and detecting any changes in the home that may cause the preheat time to change, helping maintain maximum system efficiency and reducing energy bills.

### Simple installation

Installing these underfloor controls is straightforward. With minimal wiring and an easy set-up process, the controls can be installed quickly and with ease with the wireless NeoAir V2-M providing even greater flexibility for installation. Suitable for new installations and compatible with existing installations, the minimal commissioning saves additional time on site.

## Controls

All Uflex controls are compatible with the Uflex and Uflex MINI systems and are suitable for installation compatible with air source heat pumps, solar thermal systems and most boiler technologies.



Uflex Neostat V2 with Uflex UH8 Wiring Centre	Uflex Edge with Uflex UH8 Wiring Centre	Uflex NeoAir V2 with Uflex UH8-RF Wiring Centre
Mains powered digital programmable room thermostat with 8 zone mains powered wiring centre	Mains powered digital programmable room thermostat with 8 zone mains powered wiring centre	Battery powered, wireless programmable room thermostat with 8 zone mains powered wiring centre
Up to 4 actuators can be wired to each zone, allowing for up to 32 actuators to be connected to the wiring centre	Up to 4 actuators can be wired to each zone, allowing for up to 32 actuators to be connected to the wiring centre	Up to 4 actuators can be wired to each zone, allowing for up to 32 actuators to be connected to the wiring centre
Touch sensitive buttons with clear display interface controls up to 4 heating levels & backlight proximity sensor	Mechanical buttons with clear display interface controls up to 6 heating levels	Touch sensitive buttons with clear display interface controls up to 6 heating levels
Ideally suited for installations where a secure WiFi connection is established	Ideally suited for installations which do not want to be dependent on WiFi connectivity	Ideally suited for installations where a secure WiFi connection is established
Can be controlled via mobile devices with the neoHub app when paired to the neoHub (using the home's internet router)	Not compatible with neoHub or neoHub app but incorporates own RF connection for connection with wireless sensors	Can be controlled via mobile devices with the neoHub app when paired to the neoHub (using the home's internet router)
When connected to the neoHub, third party integration can be enabled (for example with GoogleHome and Alexa)	Integrates with Modbus Connectivity for connection to building management systems	When connected to the neoHub, third party integration can be enabled (for example with GoogleHome and Alexa)
Programmable room thermostat with built in air sensor	Programmable room thermostat with built in air sensor and can be used as a time clock	Programmable room thermostat with additional function of a hot water timer
Remote air sensing mode is available with wireless air and door/window sensors when the Uflex Neostat V2 is connected to and controlled via neoHub app	Remote air sensing mode is available with up to 16 wireless air and door/window sensors when paired via Uflex Edge's in-built RF connection	Remote air sensing mode is available with wireless air and door/window sensors when the Uflex NeoAir V2 is connected to and controlled via neoHub app
Remote air/floor temperature monitoring via wired sensors or multiple air sensors*	Compatible with Wireless Air sensors*. Remote air temperature monitoring via wired air sensor also available	Can be used with either 1x remote sensor or multiple Wireless Air sensors*
Remote floor temperature monitoring is available via wired floor sensor	Remote floor temperature monitoring is available via wired floor sensor	Remote floor temperature monitoring is available via wired floor sensor
230v supply required	230v supply required	230v supply required
Pump and valve exercise	Pump and valve exercise	Pump and valve exercise

\*when used with NeoHub





## Uflex NeoHub (UFLEX 70)

- The gateway to the Neo system providing remote control of all Neo thermostats from an iOS or Android device
- Connects to a home broadband router via an Ethernet cable (supplied) and wirelessly to the NeoStat and NeoAir thermostats installed in the property
- Creates a mesh network, greatly increasing the network range
- Smart Profiles: Allowing time and temperature settings to be made and then applied to a number of zones as required
- Geo-location: Automatically turns the heating off when you leave home and back on when you return
- Compatible with up to 32 Neo devices
- Compatible with Smart Home, HomeKit, Google Home, Alexa and IFTTT
- Automatic Firmware updates for NeoHub and connected devices
- Clock sync and BST correction
- Push notifications such as high/low temperature alerts, low battery warning for wireless sensors, door/window open alert (if door/window sensor is used)



## Uflex Remote Air/Floor Sensor (UFLEX 65)

- Can be used to monitor and control the floor temperature with either the Uflex Edge, NeoStat or NeoAir thermostats and is directly wired to the floor sensor terminals provided on either thermostat
- Can also be used to provide remote air temperature sensing with the Uflex NeoStat or NeoAir thermostats and is directly wired to the air sensor terminals provided on the thermostat. In this case wall-mounted Remote Sensor Enclosure (UFLEX66) can be used to conceal the temperature sensor probe
- 3 meter sensor cable which can be extended up to 20 metres using suitable 'twisted pair' shielded cable



## Uflex Remote Sensor Enclosure (UFLEX 66)

- Wall mounted enclosure used to conceal the probe of the Remote Air/Floor Sensor probe when it is used as a remote air sensor in conjunction with Uflex Neostat or Uflex NeoAir



## Uflex Thimble Sensor (UFLEX 67)

- Used to provide a discrete means of remote air temperature sensing with the Uflex NeoStat and NeoAir thermostats.
- 1.95m sensor cable which can be extended up to 20 metres using suitable 'twisted pair' shielded cable



## Uflex Wireless Air Sensor (UFLEX 68)

- Can be directly paired to the Uflex Edge thermostat via an 868MHz RF signal
- Helps calculate an average space air temperature (ideal for open plan properties)
- Can also be used instead of the internal temperature sensor of the thermostat when it is not possible to locate it in an optimal position
- A maximum of 16 wireless air sensors and window/door sensors can be connected to a single Uflex Edge thermostat



## Uflex Wireless Door/Window Sensor (UFLEX 69)

- Automatically switches the heating to standby when the door/window is open, automatically returning to the normal heating mode when shut
- Can be directly paired to the Uflex Edge thermostat via an 868MHz RF signal
- A maximum of 16 wireless air sensors and window/door sensors can be connected to a single Uflex Edge thermostat
- Uflex Neostat and NeoAir thermostats can be used with single or multiple wireless door/window sensors (via the NeoHub and NeoApp)
- Powered by a single LS14250 3.6V battery
- Can be fitted to a door or window frame using double-sided adhesive patches (supplied)

## Remote and Wireless Sensor Compatibility

	Uflex Edge	Uflex NeoStat V2	Uflex NeoAir V2-M
Remote Air/Floor Sensor (UFLEX65)	Yes <sup>1</sup>	Yes <sup>2</sup>	Yes <sup>3</sup>
Thimble Sensor (UFLEX67)	No	Yes	Yes
Wireless Air Sensor (UFLEX68)	Yes	Yes <sup>4</sup>	Yes <sup>4</sup>
Wireless Door/Window Sensor (UFLEX69)	Yes	Yes <sup>4</sup>	Yes <sup>4</sup>

Notes:

<sup>1</sup> Only one can be connected - floor temperature sensor only

<sup>2</sup> Two can be connected - either floor temperature sensor or remote air sensor (or both)

<sup>3</sup> Only one can be connected - either as floor sensor or remote air sensor (but not both)

<sup>4</sup> Only via the Neohub and NeoApp



## Afinia Aluminium Radiators

The Afinia Aluminium radiators combine functionality and aesthetics to deliver the ideal partner for both traditional and renewable heating systems. Available in horizontal and vertical options, the Afinia radiators are superb conductors of heat and incredibly responsive, heating up and cooling down quickly. Their curved design and sleek appearance also make them a stylish addition to any room.





# Afinia Range

Grant's Afinia aluminium radiators are more efficient than traditional radiator materials, such as steel and cast iron. Aluminium has excellent thermal conductivity and this, combined with their low water content, makes these radiators incredibly effective. With low energy consumption, Afinia radiators can therefore provide cost savings for householders on their energy bills.

Being a great conductor of heat, aluminium radiators heat up and cool down very quickly, enabling them to rapidly respond to any changes in the temperature demand set via the thermostat. Afinia radiators can heat up a room in a short amount of time once set to do so by the thermostat and, equally, if the temperature setting is reduced, they will cool down quickly as well. This functionality makes the Afinia radiators incredibly adaptive heat emitters, delivering maximum room comfort.



## Compatibility & flexibility

Afinia aluminium radiators can be installed with high and low temperature heating systems which makes them compatible with all of Grant's heating products. Their performance levels, which comply with European requirements, make the Afinia range an ideal partner for renewable appliances in particular. With their smaller size, compared to steel radiators, the Afinia models work incredibly effectively with air source heat pumps.

Supplied fully assembled and available in both horizontal and vertical options, the Afinia range is adaptive to suit the location where it will be sited. The horizontal radiators are available in three heights – 430mm, 580mm and 680mm – with 6 to 15 section combinations, delivering choice and flexibility when it comes to installation. Meanwhile, the vertical models are supplied with 6 or 8 sections and are available in two heights – 1,842mm and 2,042mm – providing the perfect solution when space is limited.

## Simple installation

Afinia radiators have a number of features which make for an easy installation. They are light in weight and manageable for a single engineer to install. Each Afinia radiator comes with robust steel wall brackets which allow for the straightforward mounting of each radiator. In addition, no electricians are involved with the fitting of these aluminium radiators which allows for a quick installation, reducing installation costs.

## Aesthetics

One of the distinctive features of radiators' aesthetics is their curved, rounded surface. This design makes them stylish in appearance allowing them to subtly suit their environment. Slim in build and supplied in an off-white colour finish, Grant's Afinia radiators can suit many a home's bespoke requirements.

## Peace of mind guaranteed

All the models within the Afinia aluminium radiator range are supplied with a 15 year guarantee, reflecting their quality of build. Following extensive testing and independent verification of the radiators' efficiency, reliability and output, a market leading 15 year guarantee accompanies the Afinia aluminium radiators to provide complete peace of mind for householders.

\*Subject to full T&C's

# Afinia Range Technical Specifications



HORIZONTAL											
Code	Panels	Output W ΔT30	Output W ΔT50	Height (mm)	Width (mm)	Section Width (mm)	Depth (mm)	Section Output W ΔT30	Section Output W ΔT50	Weight Empty (kg)	Weight Full (kg)
GALU4306KIT	6	288	552	430	480	80	95	48	92	6.06	7.56
GALU4308KIT	8	384	736	430	640	80	95	48	92	8.08	10.08
GALU43010KIT	10	480	920	430	800	80	95	48	92	10.10	12.60
GALU43012KIT	12	576	1104	430	960	80	95	48	92	12.12	15.12
GALU43014KIT	14	672	1288	430	1120	80	95	48	92	14.14	17.64
GALU5806KIT	6	366	744	580	480	80	95	61	124	8.10	10.14
GALU5808KIT	8	488	992	580	640	80	95	61	124	10.80	13.52
GALU58010KIT	10	610	1240	580	800	80	95	61	124	13.50	16.90
GALU58012KIT	12	732	1488	580	960	80	95	61	124	16.20	20.28
GALU58014KIT	14	854	1736	580	1120	80	95	61	124	18.90	23.66
GALU58015KIT	15	915	1860	580	1200	80	95	61	124	20.25	25.35
GALU6806KIT	6	432	852	680	480	80	95	72	142	9.60	11.94
GALU6808KIT	8	576	1136	680	640	80	95	72	142	12.80	15.92
GALU68010KIT	10	720	1420	680	800	80	95	72	142	16.00	19.90
GALU68012KIT	12	864	1704	680	960	80	95	72	142	19.20	23.88
GALU68014KIT	14	1008	1988	680	1120	80	95	72	142	22.40	27.86
GALU68015KIT	15	1080	2130	680	1200	80	95	72	142	24.00	29.85



VERTICAL											
Code	Panels	Output W ΔT30	Output W ΔT50	Height (mm)	Width (mm)	Section Width	Depth (mm)	Panel Output W ΔT30	Panel Output W ΔT50	Weight Empty (kg)	Weight Full (kg)
GALUV18426KIT	6	816	1626	1842	480	80	80	136	271	15.48	19.56
GALUV18428KIT	8	1088	2168	1842	640	80	80	136	271	20.64	26.08
GALUV20426KIT	6	882	1758	2042	480	80	80	147	293	16.86	21.36
GALUV20428KIT	8	1176	2344	2042	640	80	80	147	293	22.48	28.48



## Grant Solar Range

Solar Thermal Systems from Grant allow householders to utilise the power of the sun to provide hot water to their home. An environmentally responsible alternative to traditional energy sources and fossil fuels, solar thermal technology has zero CO<sub>2</sub> emissions and efficiently uses the energy from the sun within a central heating system. Grant Solar Thermal systems are compatible with different types of roof and easily incorporate into an existing or new heating system so accessing the benefits of the inexhaustible supply of sunshine is made simple and easy.





## Introduction to Solar Thermal

Energy is produced from the sun throughout the year, even on cloudy days, so finding ways to transfer this energy into the home is becoming increasingly popular. Solar thermal technology can produce the energy required to heat a home's hot water almost all year round while also being an excellent way for homeowners to reduce their carbon footprint. Once installed, solar thermal is a cost effective and sustainable addition to any home's heating system.

### The basic principles

Solar thermal collectors efficiently extract the energy from the sun and transfer it into a home's hot water system. Roof-mounted solar collectors are connected to a system which contains a special glycol/water solution. While passing through the collector, this fluid is heated up and then circulated from the panel through to a cylinder where the heat is transferred to produce hot water.

### Free energy

Solar collectors do not only work in the summer, contrary to what some people may believe. The sun's free energy is available throughout the year so solar collectors also work all year round too. Collectors, such as those supplied by Grant, operate in both direct sunlight and in diffused sunlight so, even on cloudy days, they are working. During the months of May through to September in particular, solar thermal can produce 100% of the energy required to meet a home's domestic water needs.

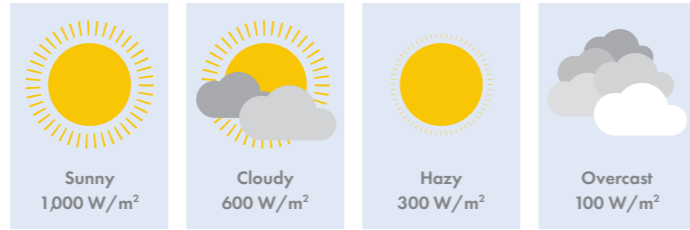

In the UK and Ireland, the amount of available solar radiation varies. The diagram here shows the total average solar radiation falling on 1m<sup>2</sup> surface, inclined at 30° to the horizontal, measured in kilowatt hours. The average property requires approximately 3,000kWh per year for domestic water heating so, as the diagram demonstrates, solar energy can provide a significant proportion of this.

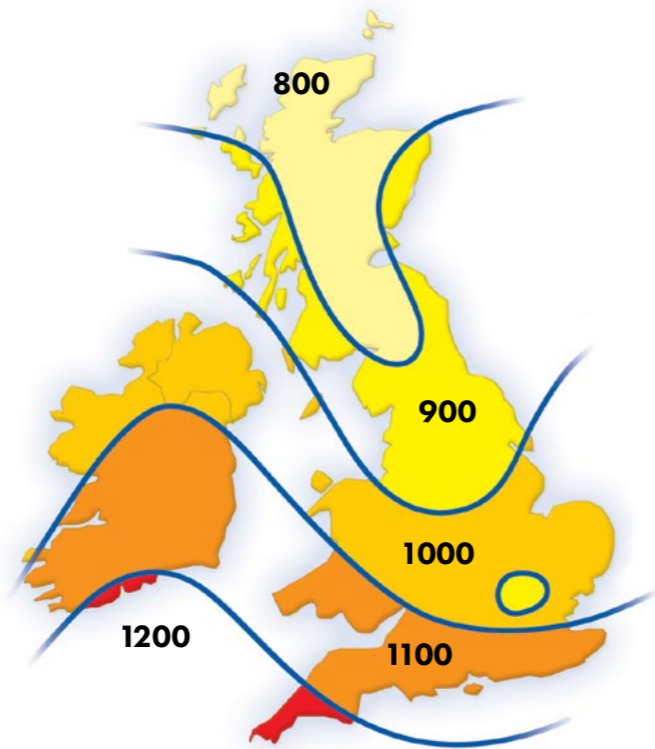

### Fit for the future

Installing solar thermal technology is beneficial in a number of ways. Not only is it a clean, sustainable method of providing homes with their hot water, a solar thermal system can also save householders up to 70% on their annual hot water heating costs. Furthermore, adding solar heating technology to a property can increase its value. Houses with solar heating are less prone to fluctuations in heating prices, making them an attractive option for potential buyers.

## Grant Solar Thermal Technology

The Grant Solar Thermal range includes the high efficiency Sahara flat plate collector, multifunctional controller with LCD display, and various roof mounting options. In addition, the range also includes the unique Grant CombiSOL which allows solar thermal to integrate with combination boilers as well as the Grant WinterSOL which provides a fully heated cylinder of hot water during periods of low thermal gain.

### Sahara collector overview

The Grant Sahara collector has a durable extruded aluminium frame with a bronze anodised finish which has been designed to blend in with most domestic roof types. During the manufacturing process, premium materials are used to guarantee the functionality and longevity of the collectors. In addition, Grant's collectors are all tested to the requirements of BS EN 12975.

The Sahara collector has been designed to deliver maximum heat transfer. Grant use a unique patented system where the heat transfer sheet within the collector interlocks both the pipe and absorber for perfect thermal transfer. Additional aluminium plates enclose the copper pipes and this, combined with an industrial strength adhesive, result in 360° heat transfer from the absorber plate to the pipe carrying the solar fluid. Alternative systems which use a soldered absorber or an ultrasonic welded absorber provide far less contact between the pipe and heat transfer plate, making these options less efficient and more prone to water damage.

### Roof mounting options

Almost any roof type is suitable for solar thermal but, when choosing an appropriate system, there are a couple of factors worth considering. Positioning the collectors in a south facing arrangement could gain 100% of available solar energy during a day whereas a south-east or south-west facing roof will have a reduction in yield of 5-10%.

Grant's Solar Thermal systems are designed to suit both sloping and flat roofs with on-roof, in-roof and flat roof mounting arrangements available.

#### On-Roof

Using the on-roof mounting system, the Sahara collectors are quickly and easily located above the roof tiles or slates using brackets and a mounting rail attached directly to the roof trusses. This system is available with fixing brackets suitable for all roof tile types and on roof pitch ranges from 20° to 60°.

#### In-Roof

With the in-roof mounting arrangement, the collectors are set into the roof tiles or slates ensuring a low-profile appearance. The roof surface beneath is closed within an aluminium weathering cassette incorporating flashings and drainage channels. In new build applications, this mounting option offers an additional benefit of reducing roofing costs because tiles are not required beneath the installation.

#### Flat Roof

The third mounting option from Grant is the flat-roof system. This system is based upon the on-roof design with the mounting rails fitted to a rigid inclined frame structure. This method allows the collectors to be positioned quickly and easily on a flat roof or other flat surface.





# Sahara Solar Range

Grant supply their Solar Thermal Systems as a series of individually numbered kits that meet the requirements of most installations. Each kit consists of the Sahara collector(s) (either portrait or landscape), a roof mounting system, expansion vessel, pump station, controller, pipe connections and solar fluid.

## Benefits

The Sahara solar collectors from Grant, which are Solar Keymark approved, are very effective and incredibly durable. Homeowners who choose to install Grant Solar can hope to save on their annual energy bills. Furthermore, all of Grant's solar products and components are rigorously tested to ensure the highest standards of quality and reliability are met for years to come.



10 year guarantee\*



\*When installed by a G1 Installer. Subject to full T&C's.



## Features

- 82.6% collector efficiency
- Significantly lower CO<sub>2</sub> emissions
- Dramatically reduced annual fuel bills
- Minimum maintenance

## Kits

### On-Roof | Portrait

GSSKIT0	1 collector kit
GSSKIT1	2 collector kit
GSSKIT2	3 collector kit

### On-Roof | Landscape

GSSKIT1LAND	2 collector kit
-------------	-----------------

### In-Roof | Portrait | Tile

GSSKIT15	1 collector kit
GSSKIT3	2 collector kit
GSSKIT4	3 collector kit

### In-Roof | Portrait | Slate

GSSKIT16	1 collector kit
GSSKIT17	2 collector kit
GSSKIT18	3 collector kit

### In-Roof | Landscape | Tile

GSSKIT15LAND	1 collector kit
GSSKIT3LAND	2 collector kit
GSS3ILT1	3 collector kit

### In-Roof | Landscape | Slate

GSSKIT17LAND	2 collector kit
--------------	-----------------

### Flat Roof | Portrait

GSSKIT5	2 collector kit
---------	-----------------

# Solar Thermal System Design

Grant Solar Thermal can easily integrate with conventional water heating systems with installation typically taking a couple of days to complete. The diagram here shows the pump station incorporated which features an air eliminator that allows the system to be both filled and purged of air in a single operation. Unlike other arrangements, there is no need to install an air vent on the roof and also no need for frequent maintenance.

## Designing a system

Grant Solar collectors have an absorber (or nett) area of 2.14m<sup>2</sup> and, as a rule of thumb, you should allow 1.0-1.3m<sup>2</sup> of nett collector area per person. For the cylinder, they require 50-60 litres capacity per m<sup>2</sup> of nett collector area. To simplify this, for a two collector system (2 x 2.14m<sup>2</sup>) you will require a cylinder of approximately 200-250 litres which would be sufficient for four people and would satisfy up to 70% of the hot water demand per annum.

When designing a solar thermal system, there are several factors that need to be considered including:

- Location & orientation of building
- Angle of inclination (roof)
- Shading of collectors
- Collector array in m<sup>2</sup>
- Hot water requirements
- Size of cylinder
- Pipe work requirements

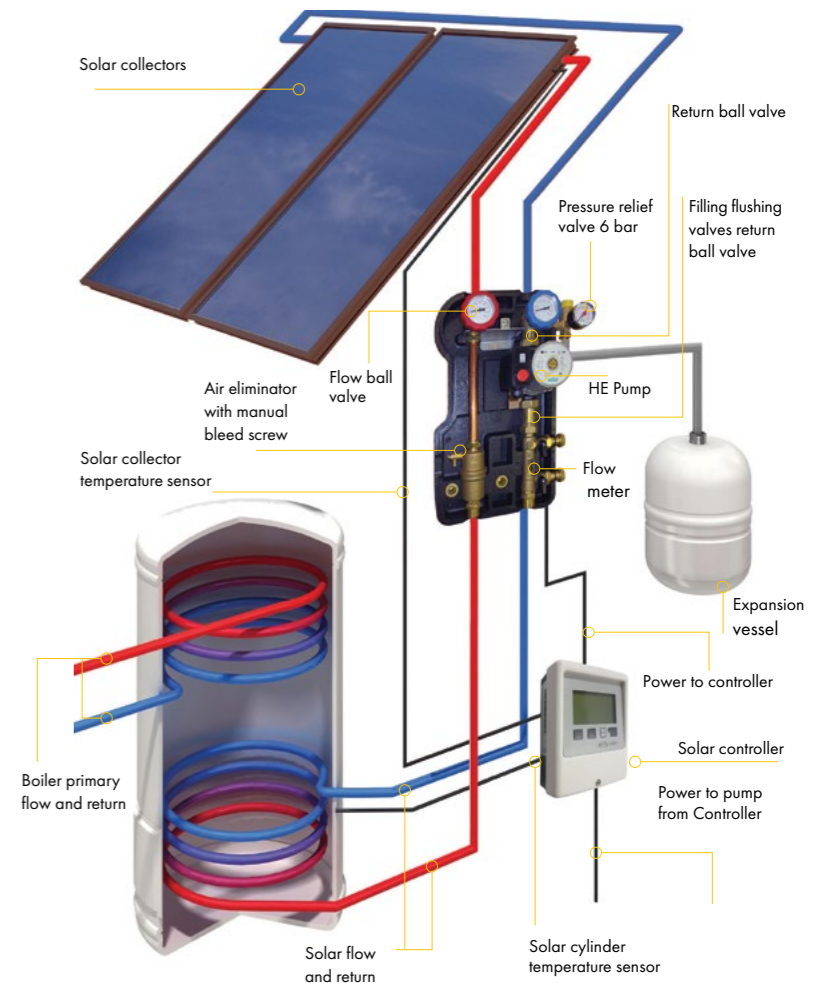

## How to calculate the number of collectors required

Direction of roof	Solar radiation kWh/Year (see map on page 34)	Number of people per household			
		<3	4	5	6
South	900 - 1000	2	2	2	3
	1000 - 1100	2	2	2	2
	1100 - 1200	2	2	2	2
South west / South east	900 - 1000	2	2	3	3
	1000 - 1100	2	2	2	3
	1100 - 1200	2	2	2	2
West	900 - 1000	2	3	3	4
	1000 - 1100	2	2	3	3
	1100 - 1200	2	2	2	3
East	900 - 1000	2	3	3	4
	1000 - 1100	2	3	3	3
	1100 - 1200	2	2	2	3





## Components

### Solar controllers

The Grant GSX1 and GSD3X differential temperature solar controllers automatically manage the operation of the solar thermal system. Monitoring the temperature in both collector and cylinder, they operate the circulating pump only when the difference in temperature will provide efficient heating of the hot water. They will also stop the circulating pump if the temperature in the collector exceeds the maximum set or, if the cylinder has reached the required temperature.



The GSX1 controller is used for simple systems, where collectors are located on the same side of a roof - such as with a south facing installation - whereas the GSD3X is utilised for more complex projects where collectors are facing the different directions, located on either the side of a roof - such as with an East/West facing installation.

Both solar controllers monitor and display the amount of solar power produced by the system on a daily and cumulative basis. The controllers can display the collector and cylinder temperatures and also incorporate a pump kick facility which activates the pump for a short period each day to prevent the possibility of seizure if not operated for more than 24 hours.

### Expansion vessel

Available in 18 and 25 litres, the expansion vessel connects to the solar pump station by a flexible hose. It incorporates a special membrane selected to withstand the higher temperatures found in solar thermal systems.



### Solar pump station

The Grant Solar pump station has been designed to be compact. The unit has a black insulating cover, housing the high efficiency circulating pump, along with all other control components and is designed for vertical wall mounting.

The flow and return ball valves incorporate temperature gauges to monitor the return and flow temperatures and have integral antigravity brakes to prevent gravity circulation around the circuit when the pump is stopped. The air separator has a manual bleed screw and allows for rapid air removal from the sealed system. The 6 bar pressure relief valve is mounted on a manifold with the system pressure gauge and expansion vessel connection.

Filling and flushing of the system is made easy by the combined fill and flush valve assembly and the adjustment of fluid flow rate is simple using the integral flow indicator.

### Solar fluid

The solar fluid is an odour-free, non-toxic 40/60 propylene glycol/water solution, developed specifically for solar thermal applications to protect systems from freezing. The nitrate, phosphate and ammonia free fluid has been formulated to remain stable over long periods of time and is also a good corrosion inhibitor. It is available ready mixed in 10 or 20 litre packs.



## CombiSOL & WinterSOL

### Grant CombiSOL

Solar thermal systems are increasing in popularity in the UK and many new and existing heating installations involve mains pressure combination boilers. A simple, cost effective solution to integrate these two technologies is therefore needed and this is precisely what the Grant CombiSOL does. It is uniquely compatible with most combi boilers and fuel types, cleverly combining the two energy sources.

The Grant CombiSOL works by accurately controlling the outlet temperature of stored secondary hot water produced by the solar thermal system. If the stored water is hot enough it directs the flow straight to the hot water outlet without passing through the combi boiler but if the water is colder it directs it via the combi boiler to the same outlet with a seamless changeover. There are additional minimal temperature fluctuations at the taps and Grant has refined the use of each valve (marked clearly on the white cap) to give optimum control of hot water delivery to the taps.

The unit also accurately regulates the inlet water temperature to the combination boiler, therefore installing the Grant CombiSOL with any combi boiler should not pose a problem, as the mixed water into the appliance is limited to a maximum of 24°C.

### Technical Information

The unique thermostatic change-over valves provide a safe and simple solution for adding renewable energies to the home without having the added expense of changing the central heating appliance. However, it is important to ensure that the combination boiler can accept an incoming cold mains water temperature of up to 24°C and Grant recommends that the boiler manufacturer is contacted to verify this.



### Grant WinterSOL

When there are times of low solar gain, the Grant WinterSOL provides a fully heated cylinder to ensure that the household's hot water demand is satisfied. During the winter months, there may not be sufficient solar (or heat pump) gain so the Grant WinterSOL has been designed to provide back-up for heating the water within the cylinder.

For example, 150 litres of hot water from a 300 litre cylinder may be insufficient. By fitting the Grant WinterSOL, a simple summer/winter switch can be operated by the homeowner, allowing the central heating boiler to heat the full contents of the cylinder. When solar gain is restored, the switch is set back to summer mode for maximum efficiency. This unit does not directly prevent solar thermal or heat pump systems from operating as it is only energised during the normal programmed hot water period.





## Guarantees

Grant's products have been designed and built to last for years. Installers and homeowners who choose the Grant brand can be assured by the reliability, quality and value of each product. To reflect the confidence that the Company has in all of their appliances, standard and extended guarantees are available throughout the ranges.

### Quality guaranteed as standard

Grant UK guarantees the manufacture of their products for a period of twelve months from the date of installation as standard, provided that the product has been installed in full accordance with the installation and servicing manual supplied. This guarantee will be extended to a total period of two years if the product is registered with Grant UK within thirty days of installation and serviced at twelve monthly intervals. Please be advised that in cases when the installation is completed more than six months from the date of purchase, the guarantee period will commence six months from the date of purchase.

Each Grant product is supplied with a copy of the standard guarantee Terms and Conditions within the supporting Installation and User Instruction documents. Grant UK strongly recommends that customers thoroughly read these Terms and Conditions to ensure that they comply and adhere to them in order to maintain their product's standard guarantee.

### Extended guarantees through the G1 Installer Network

The standard two year guarantee on Grant's renewable product ranges can be increased if the unit is installed by one of Grant UK's G1 Installers. G1 Installers can offer extended guarantees on the Grant products that they purchase, install and register. The G1 extended product guarantees are subject to the product being installed in full accordance with both the installation and servicing instructions as well as the G1 Scheme Terms and Conditions. Please note, G1 extended guarantees are only activated when the G1 Installer registers the appliance via their G1 Portal or Click App.



Grant UK's G1 Scheme provides installers with the essential tools that they need to successfully fit and endorse Grant products, which in turn gives members confidence in the products they install. Homeowners who choose a G1 engineer can be confident that their Grant product is installed to the highest possible standards while also enjoying the peace of mind that comes with the extended guarantees that G1 installers can activate on their installations.

Homeowners looking to find a G1 Installer in their local area should visit Grant UK's website and use the Find an Engineer online search: [www.grantuk.com/support/find-an-engineer](http://www.grantuk.com/support/find-an-engineer).









### Extended Warranty Packages

When a Grant product is not installed by a G1 Installer, homeowners can still increase the warranty on their appliance. Grant UK offer a range of three year extended warranty options which are exclusively available for products (including heat pumps and cylinders) registered within thirty days of installation. These are designed to give homeowners added peace of mind after the standard two year product guarantee has expired.

To read more about the extended product warranties available to purchase from Grant UK, please visit: [www.grantuk.com/support/extended-warranties](http://www.grantuk.com/support/extended-warranties).

## Guarantees

Provided below is a summary of the standard and G1 extended guarantees which are available from Grant UK on their renewable product ranges.

			
	Aerona <sup>3</sup> ASHP	2 years	7 years*
	VortexAir Hybrid	2 years	5 years*
	Solar Thermal Collector	5 years	10 years
	Kit	5 years	5 years
	Cylinders & Thermal stores Body	25 years	25 years
	Components	2 years	5 years
	Uflex Underfloor Heating Pipe	25 years	25 years
	Mechanical & Electrical components	2 years	2 years
	Afinia Radiators	15 years**	15 years**

All guarantees are subject to Terms & Conditions

\* Product must be fitted with Grant Mag One magnetic filter

\*\* Parts only guarantee



## Product List

### Aerona<sup>3</sup> R32 Air Source Heat Pump Range

HPID6R32	Aerona <sup>3</sup> 6kW R32 inverter driven air source heat pump c/w hoses and valves, controller & 8m lead
HPD10R32	Aerona <sup>3</sup> 10kW R32 inverter driven air source heat pump c/w hoses and valves, controller & 8m lead
HPID13R32	Aerona <sup>3</sup> 13kW R32 inverter driven air source heat pump c/w hoses and valves, controller & 8m lead
HPID17R32	Aerona <sup>3</sup> 17kW R32 inverter driven air source heat pump c/w hoses and valves, controller & 8m lead
HPIDR32PACKA	Aerona <sup>3</sup> installation pack A - S-Plan for non pre-plumbed cylinders (Components: combined volumiser/low loss header, 7 day Immersion Programmer (legionella), flexi foot kit, MagOne filter, 18L sealed system kit, wiring centre c/w DHW priority, DHW programmer, 32A AC isolator)
HPIDR32PACKB	Aerona <sup>3</sup> installation pack B - S-Plan for pre-plumbed cylinders (Components: combined volumiser/low loss header, flexi foot kit, MagOne filter, 18L sealed system kit, DHW Programmer, 32A AC isolator)
HPIDR32PACKC	Aerona <sup>3</sup> installation pack C - Direct for non pre-plumbed cylinders (Components: combined volumiser/low loss header, DHW Programmer, flexi foot kit, MagOne filter, 18L sealed system kit, heat pump wiring interface, hot water priority relay, 28mm 3-port diverter valve, cylinder sensor, 7 day Immersion Programmer (legionella), 32A AC isolator)
BLYGOLD1	Aerona <sup>3</sup> Blygold Coating Treatment (for HPID6R32, HPID10R32)
BLYGOLD2	Aerona <sup>3</sup> Blygold Coating Treatment (for HPID13R32, HPID17R32)
HPIDSYSLLHKIT	System combined volumiser/low loss header (70kW) kit c/w 2x 28mm valves
HPWPR1	Water Priority Relay
HPWPR2	Water Priority Relay (2 CH Zone)
EP001	Wiring centre
EP001X	Wiring centre (hard wired)
EP002	Heat Pump wiring interface
HPIDT205	7 day Immersion Programmer (legionella)
HPIDFOOT/KIT2	Aerona <sup>3</sup> flexi-foot kit with fixings (2 x 600mm)
HPIDINSU/KIT	Aerona <sup>3</sup> through wall insulation kit to fit 22-28mm flexi hose
HPID120	28mm 3-Port diverter valve
HPID121	10k Ohm cylinder sensor
HPIDTM4	DHW Programmer
EML/100A	Aerona <sup>3</sup> wall mounted electricity meter
HPIDHEATMETER2	Aerona <sup>3</sup> heat meter kit (compatible with HPID6R32 & HPID10R32)
HPIDHEATMETER	Aerona <sup>3</sup> heat meter kit (compatible with HPID13R32 & HPID17R32)
INHIB03	Inhibitor/ anti-freeze 25 litres
HPIDAC32	AC isolator 32 amp
HPIDWALLBRKT2	Aerona <sup>3</sup> heat pump wall bracket (M-Type 90-120kg)
HPAWSSK12	12 Litre sealed system kit
HPAWSSK18	18 Litre sealed system kit
HPAWSSK50	50 Litre sealed system kit

### VortexAir Hybrid Range

HPIDAIR1526	VortexAir comprising: VTxAIR1526 15-26kW hybrid oil boiler with Aerona3 HPID17R32 17kW air source heat pump c/w balanced flue
-------------	---

### QR Cylinders

QRSC150	Quick Recovery Single Coil 150L cylinder
QRSC180	Quick Recovery Single Coil 180L cylinder
QRSC210	Quick Recovery Single Coil 210L cylinder
QRSC250	Quick Recovery Single Coil 250L cylinder
QRSC300	Quick Recovery Single Coil 300L cylinder
QRSC210	Quick Recovery Twin Coil 210L cylinder
QRSC250	Quick Recovery Twin Coil 250L cylinder
QRSC300	Quick Recovery Twin Coil 300L cylinder
QRSC210PP	Quick Recovery Pre-Plumbed Single Coil 210L cylinder
QRSC250PP	Quick Recovery Pre-Plumbed Single Coil 250L cylinder
QRSC300PP	Quick Recovery Pre-Plumbed Single Coil 300L cylinder
QRSC150SL	Quick Recovery Single Coil Slimline 150L cylinder
QRSC180SL	Quick Recovery Single Coil Slimline 180L cylinder
QRSC210SL	Quick Recovery Single Coil Slimline 210L cylinder
QRINTSC210	Quick Recovery Integrated Single Coil 210L Cylinder

## Product List

### Sahara Solar Thermal Range

GSSKIT0	1 collector on-roof portrait kit
GSSKIT1	2 collector on-roof portrait kit
GSSKIT2	3 collector on-roof portrait kit
GSSKIT5	2 collector flat roof portrait kit
GSSKIT15	1 collector in-roof portrait tile kit
GSSKIT16	1 collector in-roof portrait slate kit
GSSKIT3	2 collector in-roof portrait tile kit
GSSKIT17	2 collector in-roof portrait slate kit
GSSKIT4	3 collector in-roof portrait tile kit
GSSKIT18	3 collector in-roof portrait slate kit
GSSKIT1LAND	2 collector on-roof landscape kit
GSSKIT15LAND	1 collector in-roof landscape tile kit
GSSKIT3LAND	2 collector in-roof landscape tile kit
GSSKIT17LAND	2 collector in-roof landscape slate kit
GSS3ILT1	3 collector in-roof landscape tile kit
COMSOL3	CombiSOL kit
WINTERSOL1	WinterSOL kit

### Uflex Underfloor Heating Ranges

UFLEX00	Uflex UFH Pipe 16X2,0 80m
UFLEX01	Uflex UFH Pipe 16X2,0 120m
UFLEX02	Uflex UFH Pipe 16X2,0 240m
UFLEX04	Uflex UFH Pipe 16X2,0 500m
UFLEX106	120M Uflex MINI 10mm UFH pipe
UFLEX107	240M Uflex MINI 10mm UFH pipe
UFLEX108	480M Uflex MINI 10mm UFH pipe
UFLEX102	100m Pex/Al/Pex 16mm Pipe
UFLEX103	250m Pex/Al/Pex 16mm Pipe
UFLEX104	500m Pex/Al/Pex 16mm Pipe
UFLEX75	Uflex Manifold SS 2X3/4 EURO
UFLEX76	Uflex Manifold SS 3X3/4 EURO
UFLEX77	Uflex Manifold SS 4X3/4 EURO
UFLEX78	Uflex Manifold SS 5X3/4 EURO
UFLEX79	Uflex Manifold SS 6X3/4 EURO
UFLEX80	Uflex Manifold SS 7X3/4 EURO
UFLEX81	Uflex Manifold SS 8X3/4 EURO
UFLEX82	Uflex Manifold SS 9X3/4 EURO
UFLEX83	Uflex Manifold SS 10X3/4 EURO
UFLEX84	Uflex Manifold SS 11X3/4 EURO
UFLEX85	Uflex Manifold SS 12X3/4 EURO
UFLEX109	Uflex Pump/Mixer
UFLEX120*	Uflex MINI overlay panel 10mm x 100mm non-foiled (pack of 10)
UFLEX121*	Uflex MINI overlay panel 10mm x 100mm foiled (pack of 10)
UFLEX122*	Uflex overlay panel 16mm x 150mm non-foiled (pack of 10)
UFLEX123*	Uflex overlay panel 16mm x 160mm foiled (pack of 10)
UFLEX124*	Uflex overlay panel 16mm x 200mm non-foiled (pack of 10)
UFLEX125*	Uflex overlay panel 16mm x 200mm foiled (pack of 10)

\*Available from September 2022



## Product List

UFLEX22	Uflex Conduit 28/23 Black 50m
UFLEX23	Uflex Multi Edging Strip With Foil Pe 50m 150x10mm
UFLEX24	Uflex Tacker Pipe Clip Long 55mm (Pack Of 300)
UFLEX26	Uflex Compression Adapter 16x2,0-G3/4"Feuro
UFLEX27	Uflex Mini Nubfoil 8pce, 6.2m <sup>2</sup> 1100x700x12mm
UFLEX28	Uflex Mini Edging Strip (Self Adhesive) 20m 80x8mm
UFLEX44	Uflex Fix Clamp Track With Glue 14-20mm C/C 50mm 1m (Pack Of 100)
UFLEX44S	Uflex Fix Clamp Track With Glue 14-20mm C/C 50mm 1m (Single)
UFLEX50	Uflex Compression Repair Connector
UFLEX51	Uflex MINI Compression Coupling
UFLEX105	Pex/Al/Pex Eurocone Coupling Set 16mm
UFLEX110	Uflex Limit Thermostat For Pump/Mixer Uflex109
UFLEX111	Uflex Manifold Low Loss Header
UFLEX112	Uflex Connection Angle Set
UFLEX91	Uflex Multi Bend Support 15-16
UFLEX116	Uflex MINI Pipe Bend Support - 10mm UFH Pipe
UFLEX115	Eurocone Coupling for Uflex MINI pipe 10X1.3
UFLEX29	Uflex Multi Uncoiler Telescop
UFLEX30	Uflex Tacker Clip Stapler Magazine 14-20mm L=700m
ULFEX57	Uflex Multi Layer Tube Cutter (26mm)
UFLEX62	Uflex NeoStat V2
UFLEX63	Uflex Edge With Modbus
UFLEX117	Uflex NeoAir V2-M Wireless Programmable Thermostat
UFLEX118	Uflex UH8-RF Wiring Centre (for NeoAir)
UFLEX64	Uflex UH8 Wiring Center (8 Zones)
UFLEX65	Uflex Floor Sensor
UFLEX66	Uflex Sensor Box
UFLEX67	Uflex Thimble Sensor
UFLEX68	Uflex Wireless Air Sensor
UFLEX69	Uflex Wirless Door Contact
UFLEX70	Uflex Hub
UFLEX71	Uflex 230V Actuator

## Product List

### Afinia Aluminium Radiator Range

GALU4306KIT	Afinia 430mm 6 panel radiator, 2 X brackets & installing kit
GALU4308KIT	Afinia 430mm 8 panel radiator, 2 X brackets & installing kit
GALU43010KIT	Afinia 430mm 10 panel radiator, 2 X brackets & installing kit
GALU43012KIT	Afinia 430mm 12 panel radiator, 2 X brackets & installing kit
GALU43014KIT	Afinia 430mm 14 panel radiator, 3 X brackets & installing kit
GALU5806KIT	Afinia 580mm 6 panel radiator, 2 X brackets & installing kit
GALU5808KIT	Afinia 580mm 8 panel radiator, 2 X brackets & installing kit
GALU58010KIT	Afinia 580mm 10 panel radiator, 2 X brackets & installing kit
GALU58012KIT	Afinia 580mm 12 panel radiator, 2 X brackets & installing kit
GALU58014KIT	Afinia 580mm 14 panel radiator, 3 X brackets & installing kit
GALU58015KIT	Afinia 580mm 15 panel radiator, 3 X brackets & installing kit
GALU6806KIT	Afinia 680mm 6 panel radiator, 2 X brackets & installing kit
GALU6808KIT	Afinia 680mm 8 panel radiator, 2 X brackets & installing kit
GALU68010KIT	Afinia 680mm 10 panel radiator, 2 X brackets & installing kit
GALU68012KIT	Afinia 680mm 12 panel radiator, 2 X brackets & installing kit
GALU68014KIT	Afinia 680mm 14 panel radiator, 3 X brackets & installing kit
GALU68015KIT	Afinia 680mm 15 panel radiator, 3 X brackets & installing kit
GALUV18426KIT	Afinia 1842mm 6 panel vertical radiator, 4 X brackets & installing kit
GALUV18428KIT	Afinia 1842mm 8 panel vertical radiator, 4 X brackets & installing kit
GALUV20426KIT	Afinia 2042mm 6 panel vertical radiator, 4 X brackets & installing kit
GALUV20428KIT	Afinia 2042mm 8 panel vertical radiator, 4 X brackets & installing kit
GALUX1G17	Afinia vertical radiator assembly gasket (pack of 100)
GALUXG21	Afinia horizontal radiator assembly gasket (pack of 100)
GALUX1N10	Afinia horizontal radiator assembly nipple
GALUX1N20	Afinia vertical radiator assembly nipple
GALUX1MQ	Afinia vertical radiator wall bracket (single)
GALUBRK430	Afinia wall bracket for 430mm section (single)
GALUBRK580	Afinia wall bracket for 580mm section (single)
GALUBRK680	Afinia wall bracket for 680mm section (single)
GALUX1KT12SM	Afinia radiator installation kit







**Grant Engineering (UK) Ltd**

**t: +44 (0)1380 736920 | e: sales@grantuk.com**

**[www.grantuk.com](http://www.grantuk.com)**



This leaflet is accurate at the time of printing but as Grant UK has a policy of continual improvement it may be superseded. We reserve the right to amend specifications without prior notice. The statutory rights of the consumer are not affected.

All products manufactured under I.S. EN ISO 9001. Grant UK additionally holds ISO 14001 accreditation.

™THE GRANT 'EZ-FIT FLUE' SYSTEM is a trade mark of Grant Engineering Limited.

@Grant Aeron<sup>3</sup>, Grant Uflex, Afinia, Grant Amba, Grant Spira, Grant Vecta, Grant SpiraVac, Grant SpiraPod, Grant Vortex, Grant VortexBlue, Grant VortexAir, Grant Solar, Grant Aurora, Grant Sahara, Grant CombiSOL, Grant WinterSOL, Grant MonoWave, Grant DuoWave, Grant ThermoWave, Euroflame and Multi Pass are registered trade marks of Grant Engineering Limited. The contents of this leaflet are fully protected by copyright and nothing can be reproduced without permission from Grant UK.

