

# INCLUSIVE GRAB

## Riser Rail Kit with Front Loading Showerhead Holder

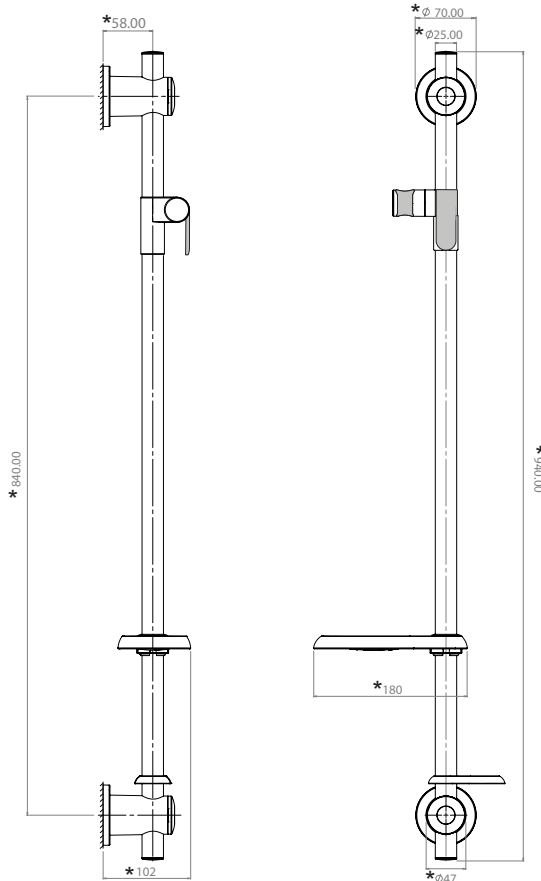

*\ast All dimensions listed regarding the product and installation are approximate. Please read the fitting instructions before proceeding.*

# Installation Instructions

INSTALLERS PLEASE NOTE THESE INSTRUCTIONS ARE TO BE LEFT WITH THE USER

## FITTING THE RISER RAIL ASSEMBLY

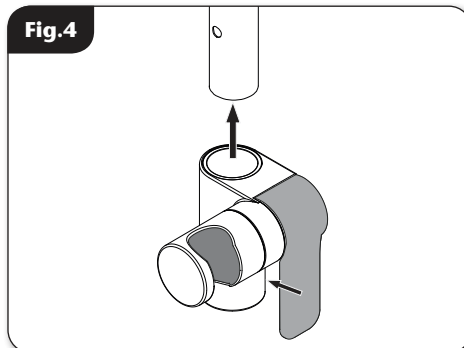
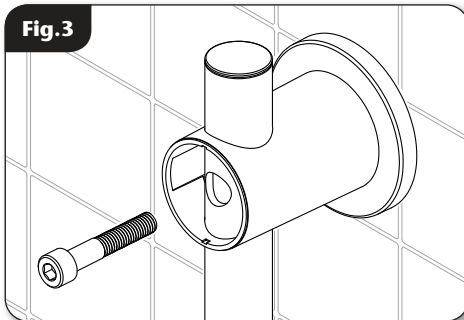
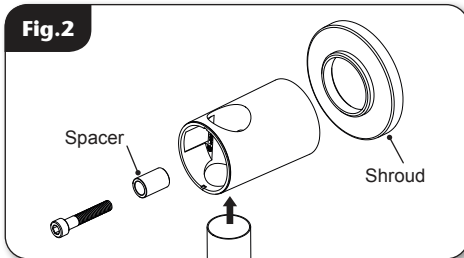
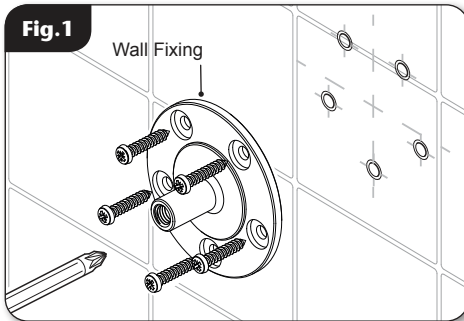

### WARNING!

**Check there are no hidden cables or pipes before drilling holes for wall plugs. Use great care when using power tools near water. The use of a residual current device (RCD) is recommended when using power tools.**

When installed as instructed, this kit can be used as a grab rail supporting up to 150kg. Suitable wall plugs and screws, for the type of wall, must be used to ensure the kit is secured properly to take the required loading.

For studed walls, an appropriate wooden batten must be inserted in the wall to fix to. Do not rely on wall fixings through tile and plasterboard only for grab rail support.

**Please note that the strength of the material being screwed into will heavily affect the loading strength of the rail.**

Place the riser rail to the wall and use both of the fixing holes to mark the position of the top and bottom wall fixings.

Position the wall fixings in place and mark the locations of the holes to be drilled. Remove the wall fixings then drill and plug the wall.

Replace the wall fixing to the wall and secure in place with 5 screws to ensure equal loading (**Fig. 1**).

**Note: Screws are not supplied with kit.**

Fit the shroud over the wall fixing and place the top bracket onto the shroud. Insert the spacer, slide the riser rail into the bracket and line up the fixing holes (**fig. 2**).

**Note: The larger of the two holes in the top and bottom of the riser rail should be facing outwards when the holes are aligned with the fixing hole in the bracket.**

Use the supplied M8 cap head screw (6mm hexagonal wrench) to fix the riser rail and bracket to the wall fixing (**fig. 3**).

To fit the showerhead holder onto the riser rail, press the lever inwards, slide the holder onto the rail (**fig. 4**). Once in place, release the lever.

## FITTING THE RISER RAIL ASSEMBLY

Slide the soapdish and hose retainer onto the bottom of the riser rail, below the holder (**fig.5**).

Fit the shroud and the bottom bracket, with spacer already inserted, onto the riser rail and screw to the bottom wall fixing.

**Note: The screw should pass through the larger hole in the base of the riser rail (fig.6) and come to rest against the inner of the riser rail to stop it from turning within the bracket.**

Fit the end caps onto both brackets. The end caps will only fit one way. Fit the riser rail trims to both ends of the rail.

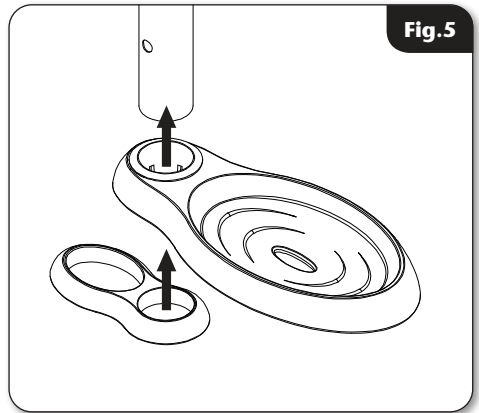

Fig.5

## FITTING THE HOSE AND SHOWERHEAD

Feed the flexible hose through the ring on the hose retainer. This is to comply with Water Regulations.

Screw the flexible hose to the shower outlet and showerhead, making sure the supplied washers are in place at both ends of the hose (**fig.7**).

Place the showerhead into the holder and check that it fits correctly (**fig.8**).

**Note: The holder is slightly tapered and the showerhead and hose will only fit from one direction.**

**IMPORTANT:** It is the conical end of the hose which grips into the holder. The showerhead will not fit in the holder without the hose attached.

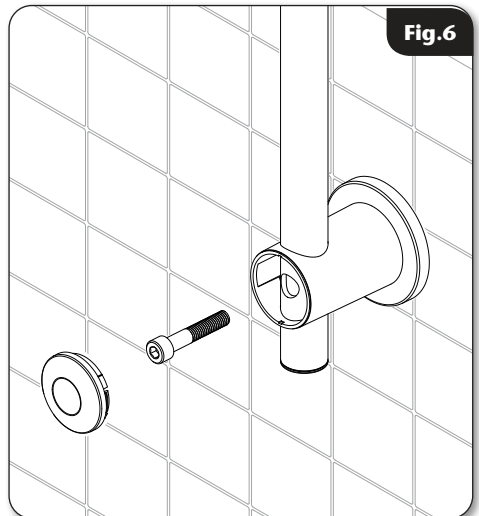

Fig.6

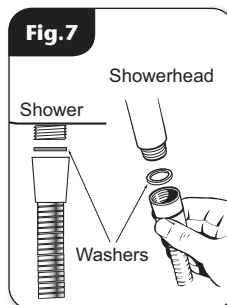

Fig.7

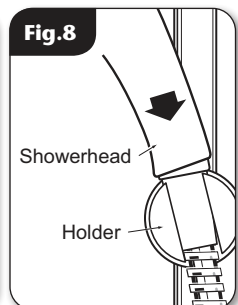
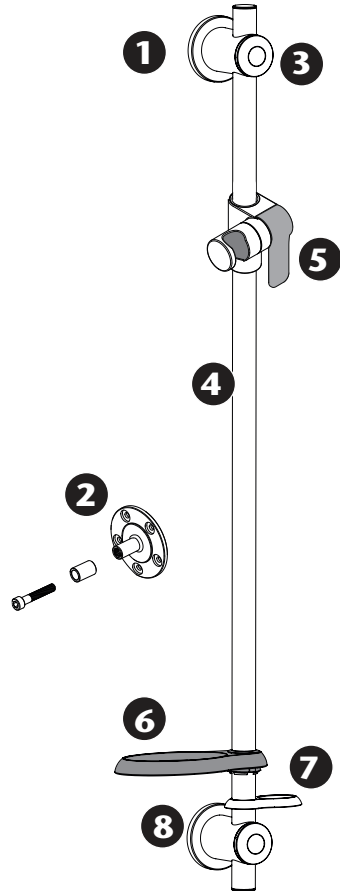

Fig.8

## SPARE PARTS

Ref.	Description	Part number
------	-------------	-------------

<b>1</b>	Bracket Set* Bracket / Cap <i>White</i> <i>Chrome</i>	83315380 83315390
<b>2</b>	Wall Fixing Set Wall Fixing / M8 Cap Head Screw / Spacer	83315410
<b>3</b>	Bracket Cap <i>White</i> <i>Chrome</i>	7054530 7054545
<b>4</b>	Riser Rail 25 mm <i>Stainless Steel</i>	88800038
<b>5</b>	Showerhead Holder <i>White/grey</i>	P84200190
<b>6</b>	Soap Dish	S86100380
<b>7</b>	Hose Retainer <i>White</i> <i>Chrome</i>	7054532 7054546
<b>8</b>	Shroud	7054542



\* Bracket set for both white and chrome contains 2 of each component.