

Dudley



- ~ Syphons, flush valves and inlet valves
- ~ Concealed and exposed WC cisterns
- ~ Urinal cisterns and controls
- ~ Wall-hung sanitaryware frames
- ~ Touch-free electronic products
- ~ Damage resistant sanitaryware
- ~ ProFit+ rewards scheme

WELCOME TO THE NEW DUDLEY BATHROOM SOLUTIONS CATALOGUE.

Thomas Dudley is committed to providing its customers with market-leading innovative bathroom products. Our catalogue has been updated with a fresh new look and is now even easier to use. We hope you find it useful.



SAVING WATER, TIME AND MONEY

Dudley bathroom and washroom solutions help to save time, water and money. We support the European Water Label and have over 500 products from the Dudley range registered under the scheme. In addition, Dudley products support, BREEAM and other water-saving initiatives.



QUALITY, RELIABILITY AND DURABILITY

We manufacture in the UK and Dudley products are recognised for delivering quality, reliability and durability. Our commitment to innovation also enables us to continually challenge conventional thinking and develop value-added products and services.



FINDING THE PRODUCTS YOU NEED

If you cannot find what you are looking for please call us on

0121 530 7000

or email us at

sales@thomasdudley.co.uk



Cert. No. FM0614



Cert. No. EMS72025



Cert. No. OHS89327

CONTENTS

4

NEW HYDROFLO INLET VALVES
HYDROFLO INLET VALVES
COMPLYING WITH WATER REGULATIONS



6 THOMAS DUDLEY



10

CISTERN COMPONENTS
NIAGARA AND VICTORIA FLUSH VALVES
TURBO AND OTHER SYPHONS
HYDROFLO INLET FLOAT VALVES
BETA AND BETA+ INLET FLOAT VALVES
RIGIFLEX WC PAN CONNECTORS



18

CONCEALED CISTERNS
VANTAGE AND MINIFLO
ROYAL PUSHFLO AND PUSHFLO
MIRAGE AND PHANTOM
PUSHBUTTONS AND PUSH PLATES

28 EXPOSED CISTERNS



34 AUTOMATIC CISTERNS



36 WALL-HUNG SANITARYWARE FRAMES



42

ELECTROFLO
ELECTROFLO FOR CONCEALED CISTERNS
ELECTROFLO FOR CERAMIC CISTERNS
ELECTROFLO URINAL CONTROLS
ELECTROFLO TAPS
ELECTROFLO KINETIC URINAL CONTROLS

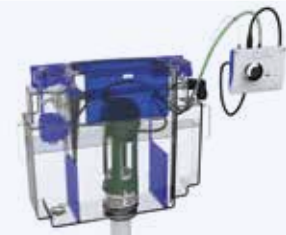

53 RESAN DAMAGE RESISTANT SANITARYWARE



62 TOILET SEATS

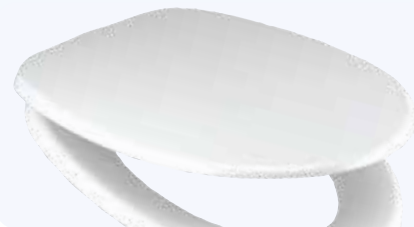

68 SPARES AND ACCESSORIES

74 TERMS AND CONDITIONS

76 CONTACT DETAILS

NEW HYDROFLO INLET VALVES COMPLY FULLY WITH WATER REGULATIONS



Following the enforcement of water regulations we have enhanced our current portfolio to provide fully compliant products that can be sold, specified and installed with confidence.

HYDROFLO® PLASTIC TAIL COMPACT FLOAT VALVE

- UK's first WRAS Approved quiet flow regulated float valve
- Perfect replacement inlet valve for most ceramic and plastic WC cisterns
- Unique integrated quiet fill action that does not compromise the air gap in any way
- Fixed height, plastic tail, bottom inlet float valve (side inlet available)
- Water saving delay fill technology
- Cost effective ½" plastic tail
- Time saving, flow regulation works for all water pressures; no need for removal
- Compact body, float arm and float
- No joints below the water line

PROVIDES TRUE
AG AIR GAP
FOR
BACKFLOW
PREVENTION

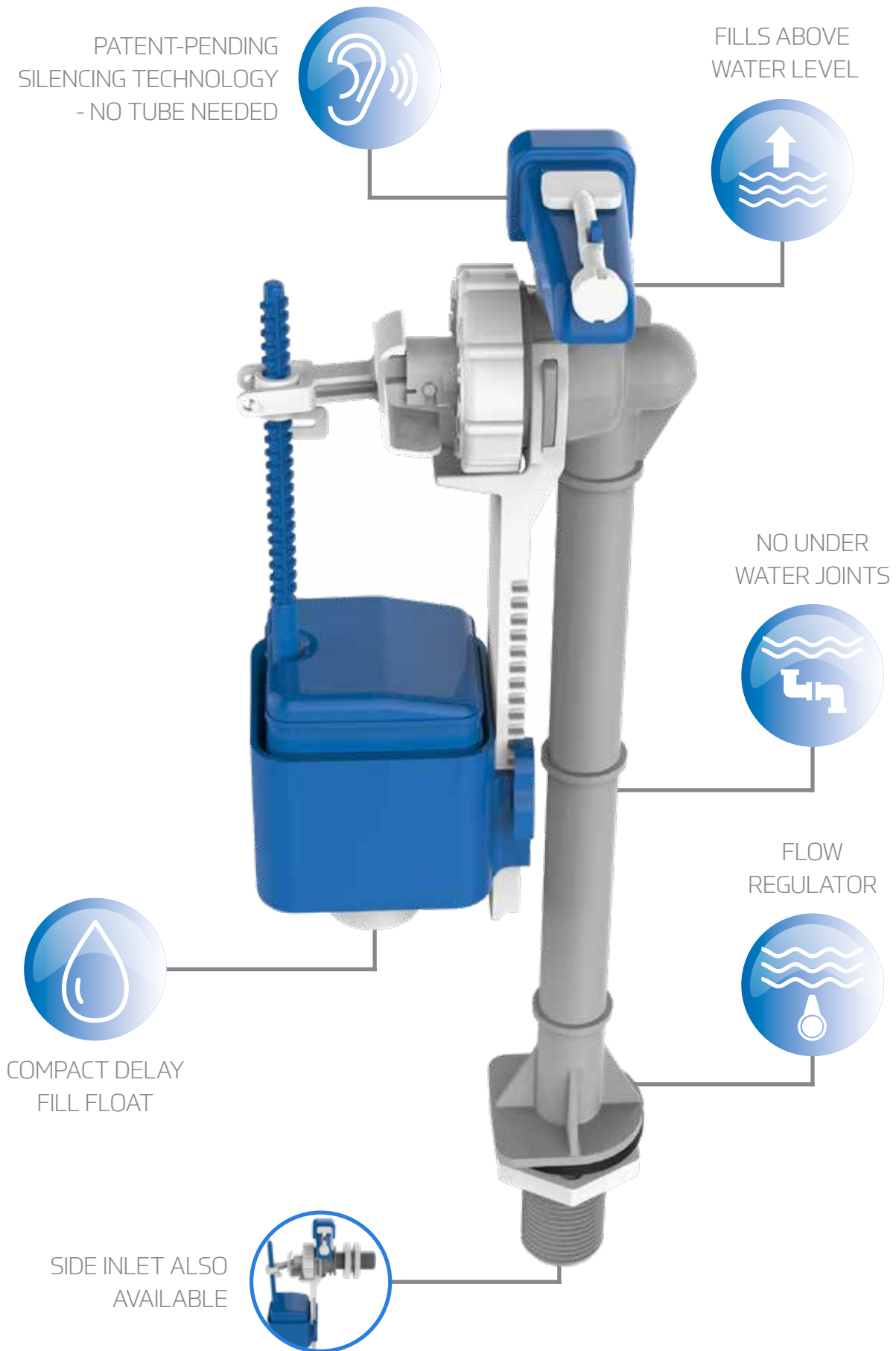



THE THOMAS DUDLEY DIFFERENCE

Thomas Dudley is a uniquely flexible, people driven organisation.

WHEN CUSTOMERS CHOOSE DUDLEY PRODUCTS THEY DO SO IN THE KNOWLEDGE THAT:



- ✓ We have been manufacturing in the UK since 1920.
- ✓ We remain a family owned and managed business.
- ✓ We have unrivalled expertise and a long serving loyal workforce. Almost 10% of our employees have been with Thomas Dudley over 25 years.



- ✓ We invest heavily in technology and call upon more than 30 Battenfeld injection moulding machines.
- ✓ We have developed the ability to work with customers in order to configure the perfect solution for any given application.
- ✓ The Dudley brand has been trusted by the trade for more than 40 years.



- ✓ An in-house facility undertakes testing to WRAS specifications and ensures that all Dudley products undergo rigorous testing before being released to customers.
- ✓ We are firmly established as the UK's market-leading manufacturer of concealed cisterns.



- ✓ Most of our products are patent protected.
- ✓ Spares are readily available to maximise working life and minimise whole life costs.
- ✓ Our unique Envirofacturing™ initiative ensures that we offer customers an environmentally responsible source of supply that can support their own green agendas.



QUALITY

Thomas Dudley is committed to manufacturing high quality products that are both innovative and extremely reliable.

Our in-house testing facility ensures that all Dudley products are rigorously tested in accordance with industry approved compliance standards and the Water Supply (Water Fittings) Regulations 1999.

With over 30 years of combined experience of product testing and compliance procedures, robust quality management is employed throughout the company. All products undergo stringent testing to ensure every customer that their product is manufactured to exacting standards.



WATER SAVING

Thomas Dudley is committed to manufacturing bathroom and washroom solutions that help to save water, energy and money.

We have supported the European Water Label since its inception and have over 5,000 Dudley products registered under the water saving scheme. These include our Vantage and Miniflo concealed cisterns which offer water-saving options of 6/4, 5/3 and 4/2.6 litre dualflush.

Our Turbo 88 syphons and Niagara flushing valves are registered on the Water Technology List which offers enhanced capital allowance incentives when businesses decide to fit them.



NEW PRODUCT WARRANTY SCHEME

As a business, Thomas Dudley is accredited to BS EN ISO 9001, BS EN ISO 14001 and OHSAS 18001. We employ robust quality control methodologies and subject all Dudley products to rigorous and exhaustive testing before they are made available to customers.

Our new Product Warranty scheme endorses our commitment to quality and ensures that any defective non-wearing parts will be replaced within the following periods after purchase:



DUDLEY PRODUCT	WARRANTY TERM
DUDLEY CONCEALED WC CISTERNS	
LEVER OPERATED	5 YEARS
PUSHBUTTON OPERATED	3 YEARS
DUDLEY EXPOSED WC CISTERNS	
LEVER OPERATED	5 YEARS
PUSHBUTTON OPERATED	3 YEARS
DUDLEY WALL-HUNG SANITARYWARE SUPPORT FRAMES AND BRACKETS	
FRAMES AND BRACKETS	5 YEARS
INTEGRAL CISTERNS INCORPORATED INTO FRAMES	3 YEARS
DUDLEY FLUSHING SYPHONS	5 YEARS
DUDLEY FLUSHING VALVES	3 YEARS
DUDLEY INLET VALVES	3 YEARS
DUDLEY ELECTRONIC TAPS	5 YEARS
DUDLEY RESAN SANITARYWARE	5 YEARS
DUDLEY WC PAN CONNECTORS	5 YEARS
DUDLEY TOILET SEATS	1 YEAR
DUDLEY KINETIC URINAL CONTROL	3 YEARS

To qualify for the above warranties, products must be registered within 14 days of purchase at: www.dudleybathroomproducts.co.uk

NEW FOR 2019

PROFIT PLUS THE REWARD SCHEME FOR PROFESSIONAL INSTALLERS

At Dudley we value the thousands of installers who buy and fit our bathroom products. That's why we've launched ProFit+ to reward you for choosing Dudley.

HOW DOES IT WORK?

- Find vouchers inside your Dudley product packaging.
- Collect points online or by using a rewards card.
- Claim the rewards you want, when you want.

REWARDS

- Coffee & breakfast vouchers.
- Free Dudley products.
- Prepaid debit card.
- Branded work and sportswear.
- Amazon technologies and more.
- Action Cam.

WHATS NEW?

- New user friendly website.
- Improved rewards and incentives.
- Increased offers and promotions.
- More interaction with you the plumber.



COLLECT



UPLOAD



REWARD



Further information is available at
www.thomasdudley.co.uk/profit



CISTERN COMPONENTS

Dudley flushing syphons, flushing valves and inlet valves have long been the cistern components of choice for thousands of installers across the UK and overseas.

Our products are designed to make installation and servicing simple and are rigorously tested before being made available to customers.



SAVING WATER

Turbo 88 syphons, Niagara valves and Hydroflo inlet valves support, BREEAM and other initiatives and are proven to significantly reduce water consumption in both domestic and commercial exposed and concealed cisterns

SAVING TIME AND MONEY

They have been developed with the installer firmly in mind and can be quickly and easily fitted and maintained.



SPARES READILY AVAILABLE

Spares are also readily available.

Please see pages 68-73, visit spares.thomasdudley.co.uk or call us on 0121 530 7000 (Sales).

Finding the perfect cistern component for every project.

	TURBO 88 (PAGE 12)	TURBO S44R (PAGE 13)	TURBO S1-11 (PAGE 13)	S7 CASCADE (PAGE 13)	S9 HI-FLO (PAGE 13)	JAPTIC (PAGE 13)	NIAGARA (PAGE 11)	VICTORIA (PAGE 11)	HYDROFLO (PAGE 14)	BETA/ BETA+ (PAGE 16)
FLUSHING SYPHON				
FLUSHING VALVE							.	.		
INLET VALVE									.	.
WATER-SAVING	

DUDLEY NIAGARA® MECHANICAL DUALFLUSH VALVE



WATER TECHNOLOGY LIST

BUSINESSES CAN WRITE OFF 100% OF INVESTMENT IN THE NIAGARA AGAINST TAX IN THE YEAR OF INVESTMENT

USES

- Ideal for use as a replacement in most ceramic or plastic exposed cisterns with an internal height of 330mm - 408mm.

FEATURES

- Stylish chrome plated pushbutton sits neatly in the cistern lid and incorporates easily recognisable segments for full and reduced flushes.
- Bayonet fitting enables valve body to be simply removed from the cistern.

Maintenance can then be carried out in minutes without disconnecting the water supply or dismantling the cistern.

- Long life silicon rubber seal.

- 53mm (2") outlet.

- WRAS approved.

WATER-SAVING

- 6/4 litre dualflush.
- Water Technology List registered.

DUDLEY NIAGARA® PNEUMATIC DUALFLUSH VALVE



USES

- Ideal for use as a replacement in most concealed cisterns when fitted with Dudley pushbuttons plates or sensors and supplied as standard in Vantage, Miniflo and Royal cisterns.

FEATURES

- Bayonet fitting enables valve body to be simply removed from the cistern. Maintenance can then be carried out in minutes without disconnecting the water supply or dismantling the cistern.
- Long life silicon rubber seal.
- 53mm (2") outlet.
- WRAS approved.

WATER-SAVING

- 6/4 litre dualflush or 6 single flush.
- Can be fitted as a replacement in Dudley Vantage, Miniflo and Royal Pushflo cisterns and as a replacement in most concealed cisterns when installed in conjunction with a Dudley pushbutton.

OPTIONS

- Can be operated by a wide range of pushbuttons, push plates and electronic sensors – see pages 23-26 for details.

DUDLEY VICTORIA™ CABLE OPERATED DUALFLUSH VALVE



USES

- An ideal solution to suit most situations where a flushing outlet valve is required.

FEATURES

- Stylish chrome plated pushbutton sits neatly into the lid of the cistern or will fit into the front lever hole of the cistern.

- 42mm (1½") outlet tail, supplied with adaptor for a 53mm (2") outlet.)

- Easy adjustment.

- Bayonet fixing allows easy access for maintenance.

- WRAS approved.

WATER-SAVING

- 6/4 litre dualflush.

DUDLEY TURBO 88™



**SERVICED
IN UNDER
5 MINUTES**

**WITHOUT DISCONNECTING WATER
SUPPLY AND DISMANTLING CISTERN**



Adjustable version extends from 191mm (7½") to 241mm (9½") to fit most lever operated cisterns.



324395

USES

- Ideal for use as a replacement in most ceramic exposed and plastic concealed cisterns.
- Supplied as standard in Dudley Tri-Shell cisterns and available as an optional extra in many others.

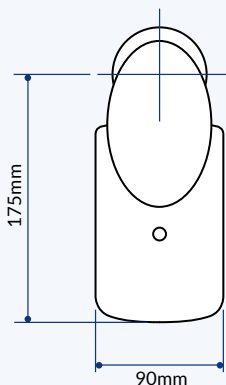

FEATURES

- 2-part design enables the syphon body to be simply removed from the cistern leaving the white downleg in position. Servicing can then be completed in under 5 minutes without having to disconnect the water supply and dismantle the cistern.
- New adjustable version extends from 191mm (7½") to 241mm (9½") to provide a convenient solution that fits most lever operated cisterns.
- WRAS approved.
- 42mm (1½") diameter outlet.
- Spares packs readily available.
- Blue body on Turbo adjustable can be retrofitted onto existing Turbo 88 downleg without dismantling a cistern.

WATER-SAVING

- 6/7/9 litre convertible.
- Dudley Duoflush delivers water saving reduced flush when lever is held down and full flush when lever is depressed and released.
- Water Technology List registered.

OPTIONS

SIZES (MM)	SIZES (INCH-ES)	CODE
178	7	313826
191	7½	316965
203	8	313639
216	8½	319023
229	9	315293
241	9½	313673
254	10	313879
191mm (7½") - 241 (9½") Adjustable		324395



**DUDLEY DUOFLUSH
SAVES WATER**
**FULL FLUSH: DEPRESS
LEVER AND RELEASE**
**REDUCED FLUSH:
DEPRESS LEVER AND HOLD**



**WATER TECHNOLOGY LIST
BUSINESSES CAN WRITE OFF
100% OF INVESTMENT IN THE
TURBO 88 AGAINST TAX IN
THE YEAR OF INVESTMENT**

DUDLEY TURBO 44™ SYPHON

WRAS approved 9 litre 2-part syphon. Suitable for high and low level use. 38mm (1½") outlet. Other sizes available: 8" - 11½".



CODE	MM	INCHES
313326	203	8
318546	216	8½
315749	229	9
313970	241	9½
316300	254	10
319200	267	10½
319764	279	11
316943	292	11½

DUDLEY TURBO S1-11™ SYPHON

WRAS approved 7 or 9 litre 2-part syphon. Suitable for high and low level use. Ideal for well-bottomed cisterns. 38mm (1½") outlet.



CODE	OPTION	MM	INCHES
317449	BRASS OUTLET AND NUTS (RUBBERLINE)	229	9
318743	PLASTIC OUTLET AND NUTS (RUBBERWELL)	229	9

DUDLEY S7 CASCADE™ SYPHON

WRAS approved one piece syphon. Suitable for low level use and 6/7/9 litre convertible. 38mm (1½") outlet.



CODE	MM	INCHES
318876	191	7½
319144	203	8
316267	216	8½
317556	229	9
319551	241	9½

DUDLEY S9 HI-FLO™ SYPHON

WRAS approved one piece syphon. Suitable for high and low level use and 6/7/9 litre convertible. 38mm (1½") outlet.



CODE	MM	INCHES
317963	191*	7½*
315308	203*	8*
313553	229*	9*

*Other sizes available – please enquire.

DUDLEY JAPTIC® SYPHON

One piece 9 litre syphon. Suitable for high and low level use. 38mm (1½") or 32mm (1¼") outlet.



CODE	SIZE
319077	229MM (9")*. 1¼" OUTLET FOR HL
315969	229MM (9")*. 1½" OUTLET FOR HL
319184	229MM (9")*. 1½" OUTLET FOR LL

*Other sizes available – please enquire.

SYPHON SPILLOVER DIMENSIONS

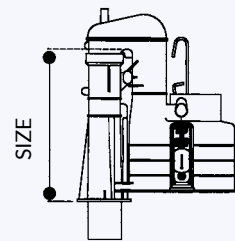

ALL SYPHON SIZES INDICATE HEIGHT FROM BOTTOM OF DOWNLEG TO SPILLOVER.

NEW DUDLEY HYDROFLO®

NEW Options Comply Fully With Water Regulations



NEW HYDROFLO PLASTIC TAIL COMPACT FLOAT VALVE

BOTTOM INLET
AVAILABLE IN SIZES
203MM (8") - 292MM (11½")

TYPE	SIZE	CODE
Bottom Inlet Plastic tail	203MM (8")	334840
	216MM (8½")	334841
	229MM (9")	334842
	241MM (9½")	334685
	254MM (10")	334843
	267MM (10½")	334708
	279MM (11")	334844
	292MM (11½")	334845



TYPE	CODE
Side Inlet Plastic tail	334686



Applicable to Delay Fill models only

USES

- Designed for use as a replacement in most plastic and ceramic exposed and concealed cisterns.
- Also supplied as standard or as an optional extra in Dudley cisterns.
- Complies fully with water regulations:
 - True AG Air Gap
 - No under water joints
 - No silence tube (patent-pending silencing technology)

FEATURES

- Compact body, float arm and float.
- Integrated quiet fill action.
- Unique key for simple and safe removal of the filter.
- Unique float arm makes it impossible for the float to become detached.
- Time saving, flow regulation works for all water pressures; no need for removal.
- No joints below the water line.
- WRAS approved.

WATER-SAVING

- Delay fill saves water and supports BREEAM by only allowing a cistern to start refilling once flushing is complete.

OPTIONS

- Side and telescopic* bottom inlet.
- Brass tails to help prevent cross threading**
- Delay fill facility.

*Telescopic variant is not compliant to clarified Water Regulations as of November 2019

**Brass tail is currently available with Telescopic and Side Inlet variants only

OTHER HYDROFLO® OPTIONS AVAILABLE



**TELESCOPIC
BOTTOM INLET
BRASS TAIL**

324302

TELESCOPIC BOTTOM INLET (EXTENDS FROM 8 - 11½")

TYPE	CODE
STANDARD	320714
DELAY FILL	324303
BRASS TAIL	324302
DELAY FILL WITH BRASS TAIL	324301

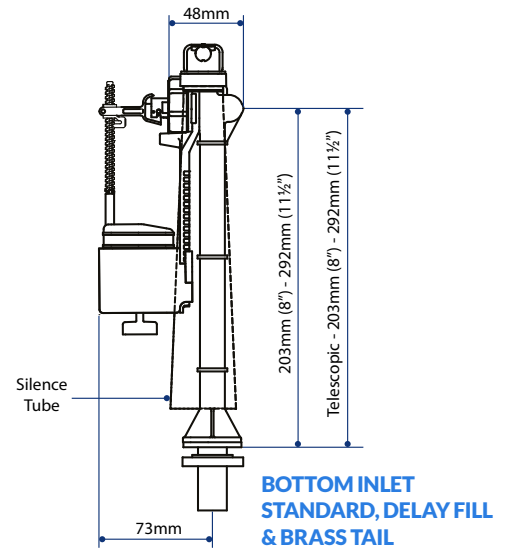

**SIDE INLET
STANDARD**

313079

**SIDE INLET
BRASS TAIL**

324299

SIDE INLET

TYPE	CODE
STANDARD	313079
DELAY FILL	324300
BRASS TAIL	324299
DELAY FILL WITH BRASS TAIL	324298



**SIDE INLET
DELAY FILL
BRASS TAIL**

324298

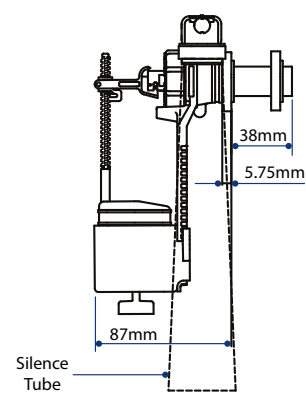
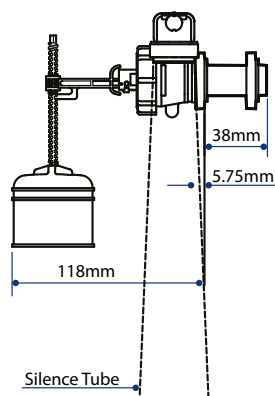

Applicable to Delay Fill models only

DUDLEY BETA+™



Side Inlet



Unique lateral float arm



Extendable float arm

USES

- Designed for use as a replacement in most plastic and ceramic exposed and concealed cisterns.

FEATURES

- Robust 'Part 3' design.
- Unique float arm can be fixed in 3 positions.
- Float arm quickly extends from 185mm (7¼") – 285mm (11¼").
- Quickly adjusts to not obstruct other cistern components.
- WRAS approved.

OPTIONS

- Fixed height and telescopic bottom inlet, side inlet.
- Plastic or professional brass tail (brass tail not available with fixed height bottom inlet).

SIDE INLET	CODES
PLASTIC TAIL	332316
BRASS TAIL	327640
BOTTOM INLET	CODES
PLASTIC TAIL BOTTOM INLET 9" (229MM)	332318
TELESCOPIC BRASS TAIL	327645



DUDLEY BETA™

Beta Float Valves to BS1212
Part 3

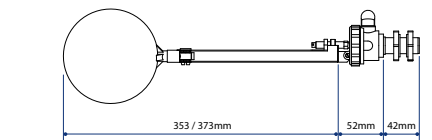
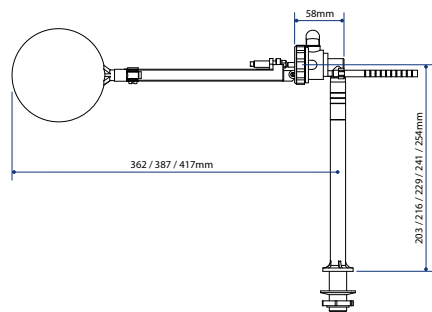

USES

- Designed for use as a replacement in most plastic and ceramic exposed and concealed cisterns.

FEATURES

- Ideal for high and low pressure (0.1 -14 bar).
- Swivel float arm.
- WRAS approved.
- Spares readily available.

OPTIONS

- Side and bottom inlet.
- Forked float arm.



FIXED BOTTOM INLET

SIZES (MM)	SIZES (INCHES)	FLOAT ARM SIZES (MM)	CODE
203	8	155	322391
		180	322392
		210	322393
216	8½	155	322394
		180	322395
		210	322396
229	9	155	322397
		180	322398
		210	322399
241	9½	155	322400
		180	322401
		210	322402
254	10	155	322403
		180	322404
		210	322405

SIDE INLET

FLOAT ARM SIZES (MM)	CODE
155	321869
180	322406
210	321713
231	331432

MULTIPACKS

Sets of internal cistern fittings can be supplied for most ceramic sanitaryware. Please enquire stating manufacturer and model.

Fitting packs typically include a flushing syphon or outlet valve, an inlet valve and a lever kit or push button. Packs can be fully tailored to meet your individual requirements to comply with the Regulator's Specification.

Using our modern in-house laboratory and life cycle testing facilities, Thomas Dudley Ltd also undertakes third party testing to water regulations compliance. These test results and associated paperwork can then be submitted to WRAS on behalf of customers for WRAS certification.



327402



325829



Fittings packs can be configured to customer specifications

DUDLEY RIGIFLEX® FLEXIBLE WC PAN CONNECTOR



313672

USES

- Provides a strong and reliable connection between the WC pan and a standard 110mm diameter soil pipe.

FEATURES

- Extends from 230mm – 570mm.
- Can be easily adjusted into an endless combination of angles to overcome even the most awkward installations.
- Seal inside collar provides water tight connection to the WC pan.
- Three raised rubber fins on the tail provide reliable connection to the soil pipe.
- Robustly constructed from polypropylene.

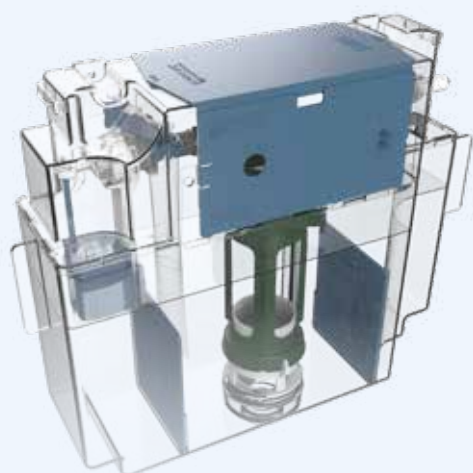

CONCEALED CISTERNS

Thomas Dudley manufactures a market-leading range of high quality concealed cisterns. These are perfect for use in all domestic and commercial applications and can be used with confidence in fitted furniture or behind tiles and most partitioning materials.



SAVING WATER

We are committed to the environment and positioned firmly at the forefront of water-saving technology. Cisterns can be supplied to deliver reliable flush volumes down to 4/2.6 litres to support, BREEAM and other initiatives. Many of our concealed cisterns are also approved by the European Water Label Scheme. In addition, delay fill inlet valves can be supplied to provide the highest levels of water efficiency by only allowing cisterns to refill once flushing is complete.

SAVING TIME AND MONEY

We also understand the need to save money on-site. As such, Dudley concealed cisterns are designed to speed up installation and servicing in order to minimise the associated costs.

UNRIVALLED FLEXIBILITY

A vast range of pushbuttons, push plates, levers and touch-free electronic sensors is available to provide the perfect finishing touch to any project. **Please refer to pages 23-26 for details.**

SPARES READILY AVAILABLE

Spares are readily available to help maximise the working life of every Dudley cistern.

Please see pages 68-73, visit spares.thomasdudley.co.uk or call us on 0121 530 7000 (Sales).



Finding the perfect concealed cistern for every project.

	VANTAGE (PAGE 19)	MINIFLO (PAGE 20)	PUSHFLO (PAGE 21)	ROYAL PUSHFLO (PAGE 21)	MIRAGE (PAGE 22)	PHANTOM (PAGE 22)
PUSHBUTTON	•	•	•	•		
PUSHPLATE	•	•				
LEVER					•	•
ELECTRONIC SENSOR	•	•				
FLUSHING (LITRES)	6/4, 5/3, 4/2.6	6/4, 5/3, 4/2.6	6, 7	6, 7	6, 7	6, 7
FRONT ACCESS	•					
TOP ACCESS	•	•	•	•	•	•

DUDLEY VANTAGE®



WRAS approved internal components.



51mm diameter Dio dualflush pushbutton.



Delay fill inlet valve saves even more water.

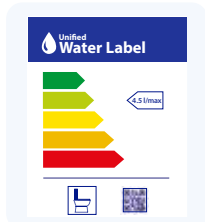

Approved by European Water Label Scheme.



USES

- Designed specifically for use in bathroom furniture.
- Also ideal for use behind tiles and partitioning and in most other concealed applications.

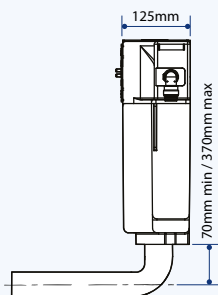
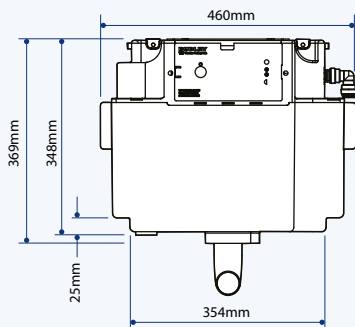

FEATURES

- Supplied factory assembled for quick and easy installation.
- WRAS approved Dudley Niagara flushing valve.
- WRAS approved Dudley Hydroflo quiet inlet valve.
- Push-fit water inlet elbow.
- Push-fit flushbend.
- Integral isolating valve.
- Air tubes enable button, plate or sensor to be installed up to 750mm away from cistern.
- Compact dimensions fit neatly into furniture units as small as 500mm(w) x 200mm(d) x 800mm(h).
- Front and top access panels.
- Unique cistern fixing brackets.
- Removes need to cut access holes into vanity tops.
- Side inlet.
- Cistern body in high density polyethylene.
- Internal overflow warning.
- The cistern complies with the Regulator's Specification.

WATER-SAVING

- 6/4 litre dualflush.
- Quickly and easily converts before or after installation to 5/3 or 4/2.6 litre dualflush.
- 6/5/4 litre single flush also available.
- Delay fill Hydroflo inlet valve only allows cistern to start refilling once flushing is complete.
- Approved by the European Water Label Scheme.
- Supports BREEAM.

OPTIONS

- Polystyrene insulation jacket.
- Odour-extracting Panfan.
- Brass tailed water inlet.

Can be supplied with a wide range of pushbuttons, push plates and electronic sensors. See pages 23-26 and 27 for details and compatibility.

DUDLEY MINIFLO®



WRAS approved internal components.



51mm pneumatic pushbutton.



Ideal behind tiles and partitioning.

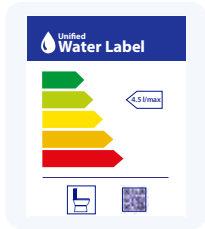

Approved by European Water Label Scheme.



USES

- Ideal for use behind tiles and partitioning and in most other concealed applications.

FEATURES

- Supplied factory assembled for quick and easy installation.
- WRAS approved Dudley Niagara flushing valve.
- WRAS approved Dudley Hydroflo quiet inlet valve.
- Push-fit flushbend.
- Air tubes enable button, plate or sensor to be installed up to 750mm away from cistern.
- Compact dimensions fit neatly into 150mm ducts.
- Top access.
- One-piece cistern fixing brackets.
- Cistern body in high density polystyrene with a durable glossy finish.
- Internal overflow warning.
- The cistern complies with the Regulator's Specification.

WATER-SAVING

- 6/4 litre dualflush.
- Quickly and easily converts before or after installation to 5/3 or 4/2.6 litre dualflush.
- 6/5/4 litre single flush also available.
- Approved by the European Water Label Scheme.
- Supports BREEAM.

OPTIONS

- Delay fill Hydroflo inlet valve that only allows cistern to start refilling once flushing is complete.
- Side or bottom inlet.

Can be supplied with a wide range of pushbuttons, push plates and electronic sensors. See pages 23-26 and 27 for details and compatibility.

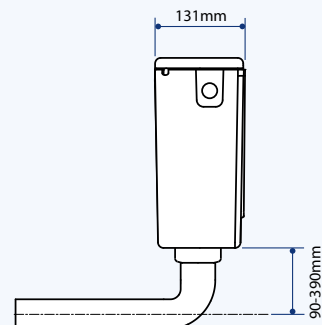
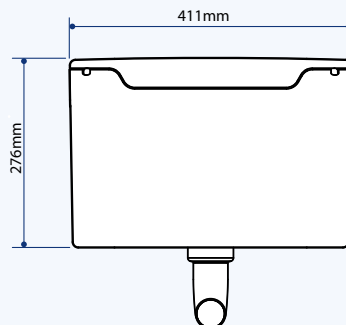

DUDLEY PUSHFLO®



WRAS approved internal components.



46mm diameter Petite single flush button.



50mm diameter Cone single flush button.



91mm diameter Dome single flush button.



USES

- Ideal for use behind tiles and partitioning and in most other concealed applications.

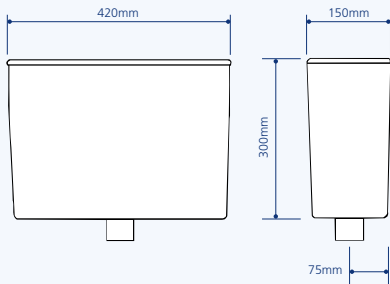

FEATURES

- WRAS approved flushing valve.
- WRAS approved inlet valve.
- Air tubes enable button to be installed up to 750mm away from cistern.
- Compact dimensions fit neatly into most ducts.
- Top access.
- Cistern body in high density polystyrene.
- Internal overflow warning.
- The cistern complies with the Regulator's Specification.

WATER-SAVING

- 6 litre single flush.

OPTIONS

- Side or bottom inlet.

Can be supplied with a wide range of pushbuttons including vandal-resistant and anti-ligature models. See pages 24, 26 and 27 for details and compatibility.

DUDLEY ROYAL PUSHFLO®

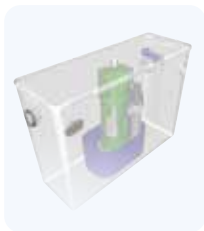

WRAS approved internal components.



51mm diameter Palm pushbutton.



51mm diameter Royal button.



USES

- Ideal for use behind tiles and partitioning and in most other concealed applications.

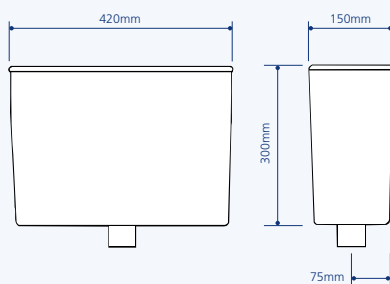

FEATURES

- WRAS approved Dudley Niagara flushing valve.
- WRAS approved inlet valve.
- Air tubes enable button to be installed up to 750mm away from cistern.
- Compact dimensions fit neatly into most ducts.
- Top access.
- Cistern body in high density polystyrene.
- Internal overflow warning.

- The cistern Complies with the Regulator's Specification.

WATER-SAVING

- 6 litre single flush.

OPTIONS

- Side or bottom inlet.
- Other flush volumes are available.

Can be supplied with a wide range of pushbuttons including vandal-resistant models. See pages 24, 26 and 27 for details and compatibility.

MIRAGE™



WRAS approved internal components.



Wide range of lever kits.

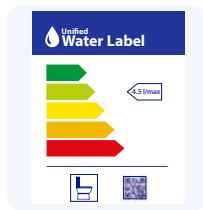

Approved by European Water Label Scheme.



USES

- Ideal for use behind tiles and partitioning and in most other concealed applications.

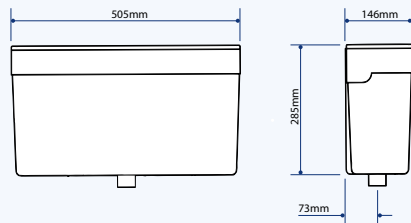

FEATURES

- Levers are fitted with vandal-resistant stops to prevent them being rotated backwards.
- WRAS approved Dudley syphon and WRAS approved Dudley Part 3 inlet valve.
- Top access.
- Internal overflow warning.
- Internal parts comply with the Regulator's Specification.
- Cistern body in high density polystyrene.

WATER-SAVING

- 6/7 litre convertible.
- Dudley Duoflush delivers water-saving reduced flush when lever is held down and full flush when lever is depressed and released.
- Approved by the European Water Label Scheme.

OPTIONS

- Wide range of lever kits to fit partition/wall thickness from 12mm – 365mm.
- WRAS approved Dudley Turbo 88.
- WRAS approved Dudley Hydroflo inlet valve.
- 9L

PHANTOM®



WRAS approved internal components.



Wide range of lever kits.

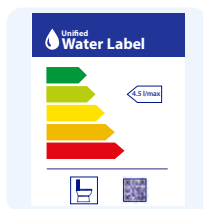

Approved by European Water Label Scheme.



USES

- Ideal for use behind tiles and partitioning and in most other concealed applications.

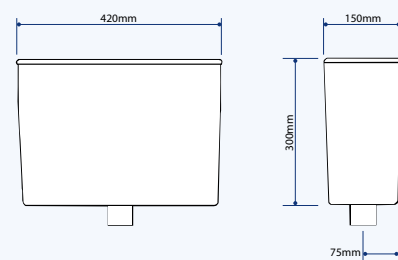

FEATURES

- Levers are fitted with vandal-resistant stops to prevent them being rotated backwards.
- WRAS approved Dudley syphon and WRAS approved Dudley Part 3 inlet valve.
- Top access.
- Internal overflow warning.
- Internal parts comply with the Regulator's Specification.
- Cistern body in high density polystyrene.

WATER-SAVING

- 6 or 7 litre.
- Dudley Duoflush delivers water-saving reduced flush when lever is held down & full flush when lever is depressed and released.
- Approved by the European Water Label Scheme.

OPTIONS

- Wide range of lever kits to fit partition/wall thickness from 12mm – 365mm.
- Can be installed with Illusion A in-wall WC support frame.
- WRAS approved Dudley Turbo 88 2-part syphon.
- Other flush volumes are available.

DUALFLUSH PUSHBUTTONS

USES

- Compatible with furniture, tiles, partitioning and walls.
- See below for cistern details.

FEATURES

- Wide range of chrome plated, mixage and white finishes.
- Smooth pneumatic operation.
- Can be positioned up to 750mm from the cistern.

51MM DIAMETER DUALFLUSH

For use with Vantage and Miniflo cisterns and Illusion A and V frames.



DIO™
Unboxed 322408
Boxed 327733



POLISHED CHROME PLATED
322905



POLISHED/MATT CHROME PLATED
322906



TWIN PALM PUSH
327655



73.5MM SQUARE/DIAMETER DUALFLUSH

For use with Vantage and Miniflo cisterns and Illusion A and V frames.

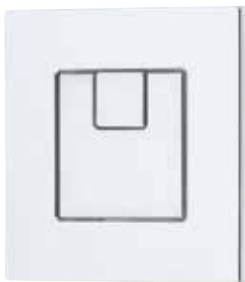

PIAZZA™ - ALSO AVAILABLE IN MATT CHROME PLATED FINISH
327734



CHROME PLATED
Unboxed 315921
Boxed 327732



MIXAGE - CHROME PLATED/ GOLD EFFECT
319900



GOLDEFFECT
318547



WHITE
331194

SINGLE FLUSH PUSHBUTTONS

46MM DIAMETER SINGLE FLUSH

For use with Pushflo cisterns.



PETITE™

320185

50MM DIAMETER SINGLE FLUSH

For use with Pushflo cisterns.



CONE™

316269

51MM DIAMETER SINGLE FLUSH

For use with Vantage, Miniflo and Royal cisterns and Illusion A and V frames.



ROYAL™

Unboxed 313621
Boxed 327735



**PALM PUSH
ROYAL™**

324379

55MM ROUND SINGLE FLUSH

For use with Vantage and Miniflo cisterns and Illusion A and V frames.



REMORA™

(ALSO AVAILABLE AS DUAL
FLUSH - PLEASE ENQUIRE)

91MM DIAMETER SINGLE FLUSH

For use with Pushflo cisterns.



DOME™

316562

73.5MM SQUARE/DIAMETER SINGLE FLUSH

For use with Vantage, Miniflo and Royal cisterns and Illusion A and V frames.

Chrome, gold effect, mixage and white finishes available in square and round surround designs.

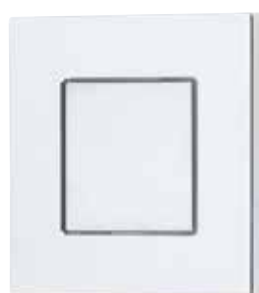

PIAZZA™

325277



MIXAGE - CHROME PLATED/GOLD EFFECT

315160



CHROME PLATED

Unboxed 313085
Boxed 327736

DUALFLUSH PLATES

Please refer to page 27 for cistern compatibility.



DUDLEY PEARL™
125MM (W) X 82MM (H) X 8MM (D)
324697

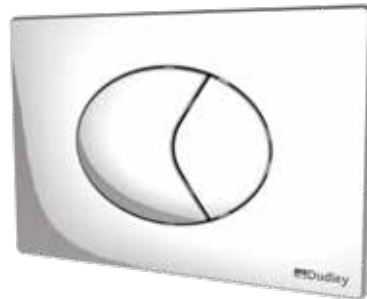

DUDLEY OYSTER™
232MM (W) X 152MM (H) X 16MM (D)
322903

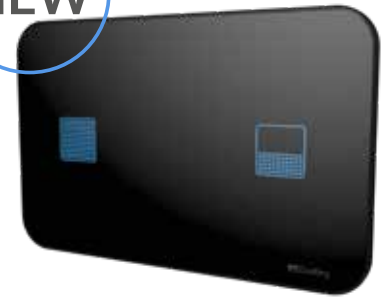

DUDLEY WAVE S3™
242MM (W) X 156MM (H) X 13MM (D)
(ALSO AVAILABLE WITH SQUARE CORNERS)
Please Enquire



DUDLEY PEARL PALM™
125MM (W) X 82MM (H) X 8MM (D)
324762



DUDLEY REEF™
232MM (W) X 152MM (H) X 14MM (D)
326393



DUDLEY WAVE S2™
229MM (W) X 149MM (H) X 10MM (D)
326395



DUDLEY PEBBLE™
232MM (W) X 152MM (H) X 16MM (D)
322904



DUDLEY CORAL™
232MM (W) X 152MM (H) X 14MM (D)
326392



DUDLEY WAVE S1™
229MM (W) X 149MM (H) X 10MM (D)
326394

USES

- Designed for use with Dudley Vantage and Miniflo concealed cisterns and Illusion A and V wall-hung sanitaryware frames.
- Compatible with furniture, tiles, partitioning and walls.

FEATURES

- Chrome plated finish.
- Smooth pneumatic operation.
- Can be positioned up to 750mm from the cistern.

WATER-SAVING

- Dualflush.
- Delivers 6/4, 5/3 or 4/2.6 litre flushing depending on Vantage and Miniflo cistern configuration.

OPTIONS

- Oyster can be supplied in bespoke colours and with corporate branding subject to sufficient demand.
- Pearl available in classic and palm push models.

- Wave S1, Wave S2, Reef and Coral can be supplied in bespoke colours and with corporate branding subject to sufficient demand.
- Wave S3 available in square or radius edges.

VANDAL-RESISTANT METAL BUTTONS

Please refer to page 27 for cistern compatibility.



METAL ROYAL™
51MM DIAMETER SINGLE FLUSH

321685



FLAT METAL
63.5MM DIAMETER SINGLE FLUSH
(FOR USE WITH PINTO VALVE)

319473

USES

- Ideal for use in all applications where there may be the potential for vandalism or misuse.
- Metal Royal button can be used with partitions, panelling or tiles up to 295mm thick.
- Flat metal button can be used with partition, panelling and tiles up to 42mm thick.

FEATURES

- High impact vandal-resistant stainless steel construction.
- Flat metal button cannot be unscrewed from the front, providing an anti-ligature solution.

OPTIONS

- Metal Royal button can be supplied with 160mm plastic bush or 368mm steel threaded rod.

VANDAL-RESISTANT METAL PLATES

Please refer to page 27 for cistern compatibility.



DUDLEY METAL PEARL™
125MM (W) X 82MM (H) X 8MM (D)

326488



DUDLEY REMORA™
229MM (W) X 149MM (H) X 10MM (D)

327227

COMPATABILITY TABLE FOR BUTTONS

Dudley push plates, pushbuttons and touch-free sensors have been specifically designed to work with our cisterns and in-wall frame systems. The table below summarises the compatibility of each.

PUSH PLATES	CONCEALED CISTERNS				WALL-HUNG SANITARYWARE FRAMES	
	VANTAGE	MINIFLO	PUSHFLO	ROYAL PUSHFLO	ILLUSION A	ILLUSION V
OYSTER	•	•		•	•	•
PEBBLE	•	•		•	•	•
PEARL BUTTON STANDARD	•	•		•	•	•
PEARL BUTTON PALM PUSH	•	•		•	•	•
WAVE S1	•*	•*		•	•	•
WAVE S2	•*	•*		•	•	•
CORAL/REEF	•	•		•	•	•
SMALL DUALFLUSH PUSHBUTTONS						
51MM DIO	•	•		•	•	•
51MM POLISHED CHROME	•	•		•	•	•
51MM POLISHED/MATT CHROME	•	•		•	•	•
51MM TWIN PALM PUSH	•	•		•	•	•
55MM REMORA	•	•		•	•	•
LARGE DUALFLUSH PUSHBUTTONS						
73.5MM PIAZZA	•	•		•	•	•
73.5 CHROME, MIXAGE, GOLD, WHITE	•	•		•	•	•
SMALL SINGLE FLUSH PUSHBUTTONS						
46MM PETITE			•			
50MM CONE			•			
51MM ROYAL, PALM PUSH ROYAL	•	•		•	•	•
55MM REMORA	•	•		•	•	•
LARGE SINGLE FLUSH PUSHBUTTONS						
73.5MM PIAZZA	•	•		•	•	•
73.5MM CHROME, MIXAGE	•	•		•	•	•
91MM DOME			•			
METAL PUSHBUTTONS						
51MM ROYAL	•	•		•	•	•
63.5MM FLAT METAL			•			
METAL PEARL PLATE	•	•		•	•	•
METAL REMORA PLATE	•	•		•	•	•
TOUCH-FREE SENSORS						
ELECTROFLO FOR CONCEALED CISTERNS 40MM SENSOR	•*	•*		•	•*	•*
ELECTROFLO FOR CONCEALED CISTERNS 40MM SENSOR SATIN STAINLESS STEEL FINISH (PLEASE ENQUIRE)	•*	•*		•	•*	•*
ELECTROFLO FOR CONCEALED CISTERNS 100MM SENSOR	•*	•*		•	•*	•*

*Electroflo Vantage and Electroflo Miniflo cisterns only.

Dualflush and single flush buttons must be installed in conjunction with dualflush and single flush cisterns respectively.



EXPOSED CISTERNS

Dudley exposed plastic cisterns have established an unrivalled track record in millions of successful installations.

Our light to medium duty cisterns are perfect for use in domestic and commercial applications whilst the Tri-Shell and Tri-Well heavy duty cisterns are proven to withstand the hardest of treatment.



SAVING WATER

Thomas Dudley is positioned firmly at the forefront of water-saving technology. Exposed cisterns can be supplied to deliver reliable flush volumes down to 4 litres to support BREEAM and other initiatives.

Many of our exposed cisterns are also approved under the European Water Label Scheme.

In addition, delay fill inlet valves can be supplied to provide the highest levels of water efficiency by only allowing cisterns to refill once flushing is complete.



SAVING TIME AND MONEY

We also understand the need to save money on-site. As such, Dudley exposed cisterns are designed to speed up installation and servicing in order to minimise the associated costs.

SPARES READILY AVAILABLE

Spares are readily available to help maximise the working life of every Dudley cistern.

Please see pages 68-73, visit spares.thomasdudley.co.uk or call us on 0121 530 7000 (Sales).

Finding the perfect concealed cistern for every project.

	ACCLAIM S (PAGE 29)	ACCLAIM V (PAGE 29)	DIPLOMAT (PAGE 30)	ELITE (PAGE 31)	SLIMLINE (PAGE 32)	TRI-SHELL (PAGE 33)	TRI-SHELL JETSEAL (PAGE 33)	TRI-WELL (PAGE 33)
PUSHBUTTON		.						
LEVER	
WATER-SAVING FLUSHING	
CLOSE-COUPLED	
LOW LEVEL	
HIGH LEVEL

DUDLEY ACCLAIM®



Dudley Turbo 88 syphon for simple servicing.



Acclaim V with chrome plated top pushbutton.



Complies with Regulator's Specification.

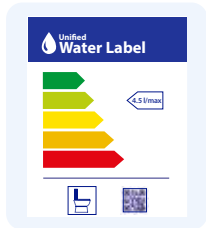

Approved by European Water Label Scheme.



USES

- Ideal for use in light to medium duty domestic and commercial applications.

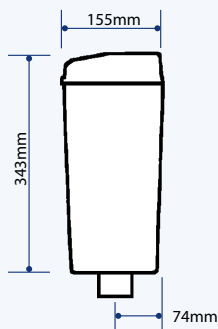
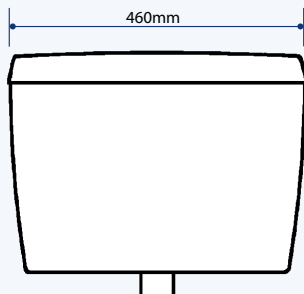

FEATURES

- Contemporary styling.
- Cistern body in high density polystyrene.
- Side inlet.
- Internal overflow warning.
- Complies with the Regulator's Specification.

ACCLAIM S

- WRAS approved one piece Dudley syphon.
- Comes with a white lever as standard.
- Suitable for high and low level installations.

ACCLAIM V

- WRAS approved Dudley Niagara flushing valve.
- Comes with a chrome plated top pushbutton.
- Suitable for low level installations.

WATER-SAVING ACCLAIM

- 6/7 litre convertible full flush.
- Dudley Duoflush delivers water saving reduced flush when lever is held down and full flush when lever is depressed and released.
- Approved by the European Water Label Scheme.
- Supports BREEAM.

ACCLAIM V

- 6/4 litre dualflush.

OPTIONS

- Dudley Hydroflo quiet inlet valve.
- Delay fill Hydroflo inlet valve that only allows cistern to start refilling once flushing is complete.
- Bottom inlet.
- 9L

ACCLAIM S

- Chrome plated lever.
- Dudley Turbo 88 Duoflush syphon for servicing in under 5 minutes without disconnecting the water supply and dismantling the cistern.

DUDLEY DIPLOMAT™



High level Dudley Diplomat with chain pull.



Dudley Turbo 88 syphon for simple servicing.



Complies with Regulator's Specification.

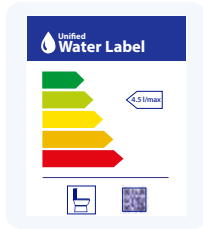

Approved by European Water Label Scheme.

USES

- Ideal for use in light to medium duty domestic and commercial applications.

FEATURES

- Traditional styling.
- Cistern body in high density polystyrene.
- Side inlet.
- Internal overflow warning.
- Complies with the Regulator's Specification.
- WRAS approved one piece Dudley syphon.
- White low level models come with white lever as standard.
- Suitable for high level, low level and close-coupled installations.

WATER-SAVING

- 6/7 litre convertible full flush.
- Dudley Duoflush delivers water saving reduced flush when lever is held down and full flush when lever is depressed and released.
- Approved by the European Water Label Scheme.
- Supports BREEAM.

OPTIONS

- White, cistern body.
- Dudley Hydroflo quiet inlet valve.
- Delay fill Hydroflo inlet valve that only allows cistern to start refilling once flushing is complete.
- Dudley Turbo 88 Duoflush syphon for servicing in under 5 minutes without disconnecting the water supply and dismantling the cistern.
- Bottom inlet.
- 9L.

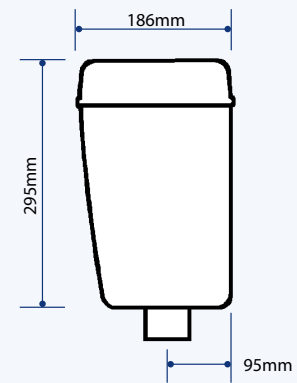
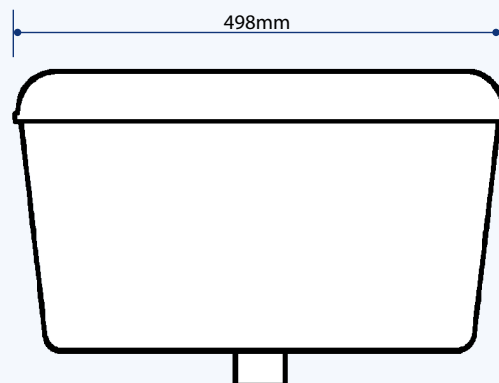

DUDLEY ELITE™



Dudley Turbo 88 syphon for simple servicing.



Projects just 140mm from wall.



Complies with Regulator's Specification.

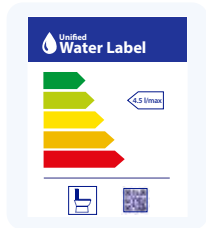

Approved by European Water Label Scheme.



USES

- Ideal for use in light to medium duty domestic and commercial applications.

FEATURES

- Classic styling.
- Cistern body in high density polystyrene.
- Side inlet.
- Internal overflow warning.
- Complies with the Regulator's Specification.
- WRAS approved one piece Dudley syphon.
- Suitable for low level and close-coupled installations.

WATER-SAVING

- 6/7 litre convertible full flush.
- Dudley Duoflush delivers water saving reduced flush when lever is held down and full flush when lever is depressed and released.
- Approved by the European Water Label Scheme.
- Supports BREEAM.

OPTIONS

- Dudley Hydroflo quiet inlet valve.
- Delay fill Hydroflo inlet valve that only allows cistern to start refilling once flushing is complete.
- Dudley Turbo 88 Duoflush syphon for servicing in under 5 minutes without disconnecting the water supply and dismantling the cistern.
- Bottom inlet.
- 9L.

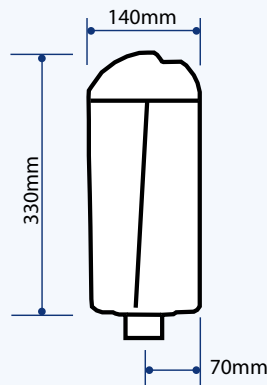
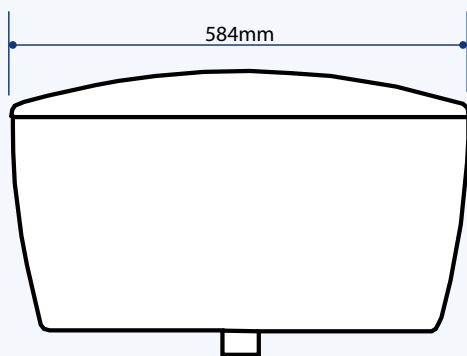

DUDLEY SLIMLINE™



High level Dudley Slimline with chain pull.



Dudley Turbo 88 syphon for simple servicing.



Complies with Regulator's Specification.

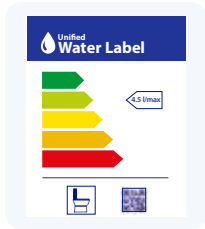

Approved by European Water Label Scheme.



USES

- Ideal for use in light to medium duty domestic and commercial applications.

FEATURES

- Traditional styling.
- Cistern body in high density polystyrene.
- Side inlet.
- Internal overflow warning.
- Complies with the Regulator's Specification.
- WRAS approved one piece Dudley syphon.
- Black and white low level models come with white lever as standard. Coloured models come with chrome plated lever. High level options supplied with chain pull.
- Suitable for high level, low level and close-coupled installations.

WATER-SAVING

- 6/7 litre convertible full flush.
- Dudley Duoflush delivers water-saving reduced flush when lever is held down and full flush when lever is depressed and released.
- Approved by the European Water Label Scheme.
- Supports BREEAM.

OPTIONS

- White, cistern body.
- Dudley Hydroflo quiet inlet valve.
- Delay fill Hydroflo inlet valve that only allows cistern to start refilling once flushing is complete.
- Dudley Turbo 88 Duoflush syphon for servicing in under 5 minutes without disconnecting the water supply and dismantling the cistern.
- Bottom inlet.
- 9L.

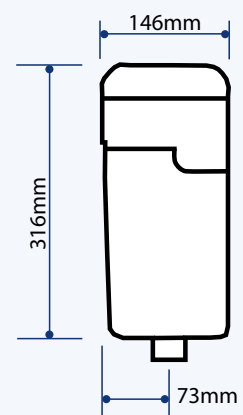
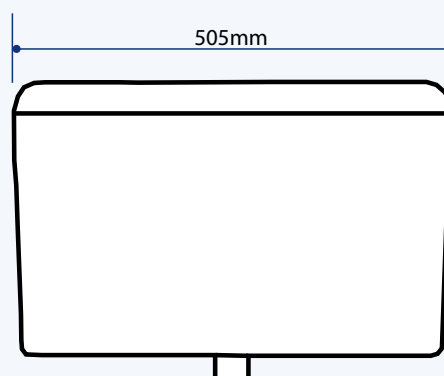

DUDLEY TRI-SHELL® TURBO™

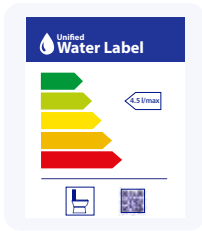

Approved by European Water Label Scheme.

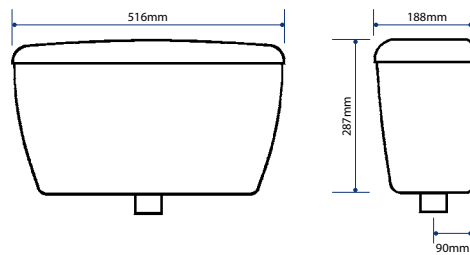

USES

- Ideal for use in most domestic and commercial applications, particularly those where there may be the potential for vandalism or misuse.

FEATURES

- Market-leading vandal-resistant features include: cistern body manufactured using a unique sandwich foam moulding process, which provides unsurpassed strength and durability, secure lid, strong metal lever or chain pull and levers fitted with metal stop to prevent them from being rotated backwards.

- Side inlet.
- Internal overflow warning.
- WRAS approved Turbo 88 2-part Duoflush syphon.
- The cistern complies with Regulator's Specification.

WATER-SAVING

- 6/7 litre convertible flush.
- Suitable for high level, low level and close coupled.

OPTIONS

- Tri-shell Jetseal Turbo option available, WRAS approved inlet valve fitted with non-wearing, chemical resistant internal parts that is proven to outlast other valves and perform perfectly even after 550,000 cycles.
- White and black cistern body.
- Bottom inlet.
- 9L.

DUDLEY TRI-WELL™ TURBO™

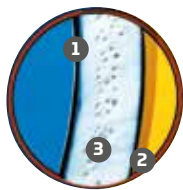

- 1 Inner Layer.
- 2 Outer Layer.
- 3 Unique, exceptionally strong cellular core.

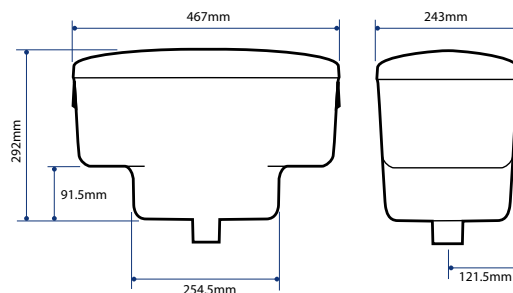

USES

- Ideal for use in most domestic and commercial high level applications, particularly those where there may be the potential for vandalism or misuse.

FEATURES

- Market-leading vandal-resistant features include: cistern body manufactured using a unique sandwich foam moulding process, which provides unsurpassed strength and durability, secure lid and strong metal lever or chain pull.
- Side inlet.
- Chain pull.
- Suitable high level installations.

OPTIONS

- Black and white cistern body. White matches existing washroom sanitaryware.
- Brass outlet and nuts.

AUTOMATIC CISTERNS

Whatever automatic cisterns are required, the Dudley range provides an ideal solution for any application. As with every Dudley product, our automatic cisterns undergo exhaustive and rigorous testing which means that when they are installed, reliability and durability come as standard.



RANGE OF SIZES

Thomas Dudley's automatic cisterns are available in a range of sizes, offering complete flexibility to suit whatever urinals are installed into a washroom. Thomas Dudley's 4.5, 9 and 13.5 litre automatic cisterns can be used to flush up to 1, 2 and 3 urinals respectively.



SPARES

Spares are readily available to help maximise the working life of every Dudley cistern.

Please see pages 68-73, visit spares.thomasdudley.co.uk or call us on 0121 530 7000 (Sales).

COMPLETE URINAL SOLUTIONS

Thomas dudley also manufactures the kinetic intelligent urinal control (see page 47), resin damage resistant urinals and accessories (see page 58) and sparge pipe kits (please enquire).



DUDLEY 'D' AUTO™



- Cistern body in high-impact polystyrene.
- High-gloss finish in white or black.
- 4.5, 9 or 13.5 litre capacities.
- Dimensions: 498mm (w) x 295mm (h) x 186mm (d).
- Outlet centre 93mm from wall.
- Supplied with automatic syphon and petcock.

DUDLEY TRI-SHELL® HEAVY DUTY AUTO



- Cistern body manufactured using a unique sandwich, foam moulding process making it exceptionally strong.
- Ideal for areas which may be subject to vandalism.
- High-gloss finish in white or black.
- 4.5, 9 or 13.5 litre capacities.
- Dimensions: 516mm (w) x 287mm (h) x 188mm (d).
- Outlet centre 90mm from wall.
- Supplied with automatic syphon and petcock.

DUDLEY ACCLAIM® AUTO



- Cistern body in high-impact polystyrene.
- High-gloss finish in white.
- 4.5 or 9 litre capacities.
- Dimensions: 460mm (w) x 343mm (h) x 155mm (d).
- Outlet centre 74mm from wall.
- Supplied with automatic syphon and petcock.

DUDLEY MIRAGE™ CONCEALED AUTO



- Perfect for use in modern concealed washrooms.
- Cistern body in high-impact polystyrene.
- 4.5, 9 or 13.5 litre capacities.
- Dimensions: 505mm (w) x 285mm (h) x 146mm (d).
- Outlet centre 73mm from wall.
- Supplied with automatic syphon and petcock.

Dudley automatic cisterns can also be supplied with the Kinetic intelligent urinal control – see page 46.



ILLUSION RANGE

The Dudley Illusion range of support frames are ideal for use with most wall-hung sanitaryware.

They also provide a proven solution behind panelling and tiles and in fitted bathroom furniture.

SAVING WATER

Illusion A and V frames incorporate an integral Vantage cistern that can be quickly and easily converted to deliver factory set to 6/4L convertible to 5/3-4/2-6L dualflush to support BREEAM and other initiatives.

Illusion Universal, Compact Universal and Freestanda frames can be installed in conjunction with any Dudley concealed cistern to provide a bespoke water saving solution.

SAVING TIME AND MONEY

Illusion frames have been specifically designed to simplify installation and minimise the associated costs.

Wall fixing brackets can be fixed at any angle through 180° whilst floor fixing brackets can be fixed through 360°.

This allows Illusion frames to be quickly fitted against flat walls and into corners or furniture.

UNRIVALLED FLEXIBILITY

A vast range of pushbuttons, push plates, levers and touch-free electronic sensors is available to provide the perfect finishing touch to any project.

Please refer to pages 23-26 for details.

Finding the perfect frame for every project.

	ILLUSION A (PAGE 37)	ILLUSION V (PAGE 38)	ILLUSION UNIVERSAL (PAGE 39)	ILLUSION COMPACT UNIVERSAL (PAGE 39)	ILLUSION FREESTANDA (PAGE 40)	ILLUSION BASIN (PAGE 41)	ILLUSION BIDET (PAGE 40)	SENTINEL (PAGE 41)
WALL-HUNG WC PAN	•	•	•	•	•			•
INTEGRAL CISTERN	•	•						
WALL-HUNG BASIN						•		
WALL-HUNG BIDET							•	

DUDLEY ILLUSION A™

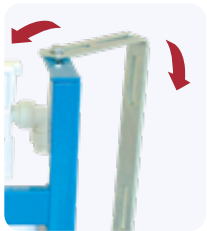

Reversible wall brackets can be fixed through 180°.

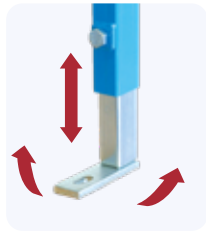

Legs are quickly and easily adjusted.

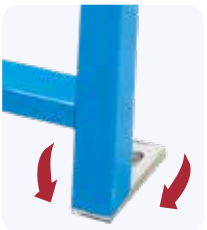

Floor brackets rotate through 360°.

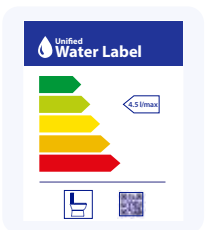

Cistern approved by European Water Label Scheme.



USES

- Wall-hung WC pan support frame designed for use against flat walls and in corners.
- Ideal for most domestic and commercial applications.

FEATURES

- Unique design enables frame height to be set between 825mm and 1120mm for unrivalled installation flexibility.
- **Height adjustable.**
- Legs adjust to offer WC pan height fixing flexibility.

- Wall and floor fixing brackets can be fixed through 180 degrees and 360 degrees respectively to simplify installation.
- Strong steel tubular section construction.
- Blue painted finish and zinc plated wall and floor brackets.
- Flushbend and WC pan connector clamps.
- Integral factory fitted Dudley Vantage cistern (see page 19).
- Floor and WC pan fixing bolts included.

WATER-SAVING VANTAGE CISTERN

- Provides 6/4 litre dualflush and quickly and easily converts before or after installation to 5/3 or 4/2.6 litre dualflush.
- 6 litre single flush also available.
- Delay fill Hydroflo inlet valve only allows cistern to start refilling once flushing is complete.
- European Water Label Scheme approved.
- Supports BREEAM.

OPTIONS

- Polystyrene cistern insulation jacket.
- Odour-extracting Panfan.

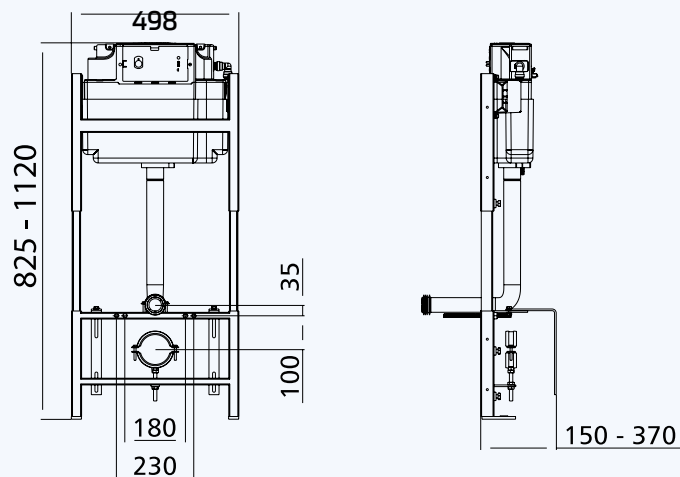

Frame height adjusts from 825-1120mm.
Feet are adjustable to allow for screeds up to 150mm thick.

Can be supplied with a wide range of pushbuttons, push plates and electronic sensors. See pages 23-26 for details and dimensions.

The Illusion A frame can also be supplied with an integral Phantom lever operated cistern - please enquire.

DUDLEY ILLUSION V™

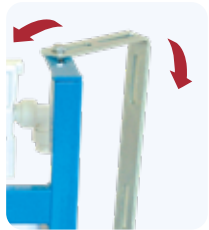

Reversible wall brackets can be fixed through 180°.

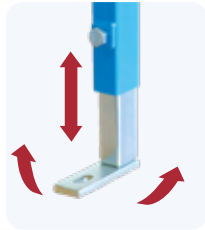

Legs are quickly and easily adjusted.



Floor brackets rotate through 360°.

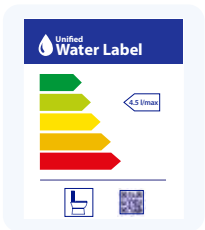

Cistern approved by European Water Label Scheme.



USES

- Wall-hung WC pan support frame designed for use against flat walls and in corners.
- Ideal for most domestic and commercial applications.

FEATURES

- Wall and floor fixing brackets can be fixed through 180 degrees and 360 degrees respectively to simplify installation.
- Legs adjust to offer WC pan height fixing flexibility.

- Strong steel tubular section construction.
- Blue painted finish and zinc plated wall and floor brackets.
- Flushbend and WC pan connector clamps.
- Integral factory fitted Dudley Vantage cistern (see page 19).
- Floor and WC pan fixing bolts included.

WATER-SAVING

Vantage cistern

- Provides 6/4 litre dualflush and quickly and easily converts before or after installation to 5/3 or 4/2.6 litre dualflush.
- 6 litre single flush also available.
- Delay fill Hydroflo inlet valve only allows cistern to start refilling once flushing is complete.
- European Water Label Scheme approved.
- Supports BREEAM.

OPTIONS

- Polystyrene cistern insulation jacket.
- Odour-extracting Panfan.

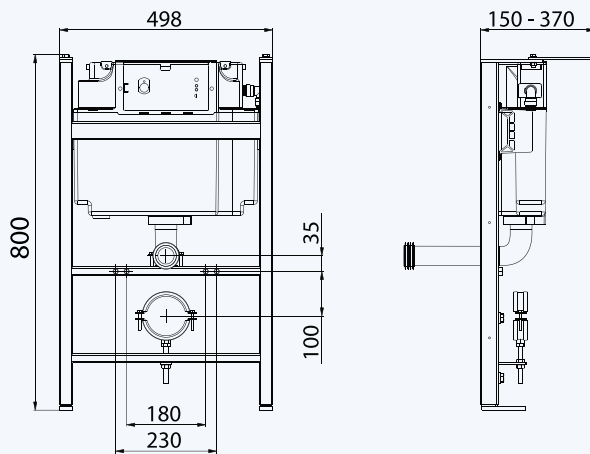

Frame height of 800mm is fixed.
Feet are adjustable to allow for screeds up to 200mm thick.

Can be supplied with a wide range of pushbuttons, push plates and electronic sensors. See page 23-26 for details and dimensions.

DUDLEY ILLUSION UNIVERSAL™



314802

DUDLEY ILLUSION COMPACT UNIVERSAL™



323082

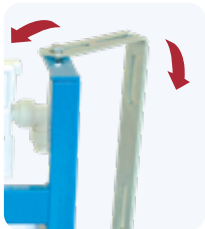
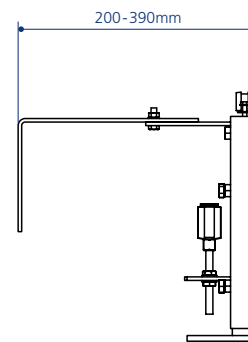
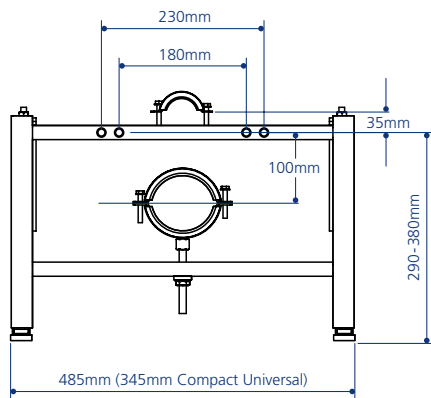

Reversible wall brackets can be fixed through 180°.

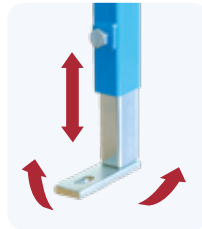

Legs are quickly and easily adjusted.

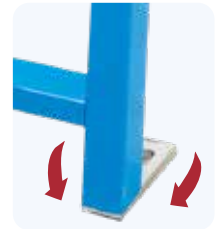

Floor brackets rotate through 360°.

USES

- Wall-hung WC pan support frame designed for use against flat walls and in corners.
- Ideal for most domestic and commercial applications. With a width of just 345mm, the Compact Universal is perfect for bathroom furniture and other confined spaces.

FEATURES

- Wall and floor fixing brackets can be fixed through 180 degrees and 360 degrees respectively to simplify installation.
- Legs adjust to offer WC pan height fixing flexibility.
- Strong steel tubular section construction.
- Blue painted finish and zinc plated wall and floor brackets.

- Flushbend and WC pan connector clamps.
- Floor and WC pan fixing bolts included.

OPTIONS

- Can be installed in conjunction with all Dudley concealed cisterns to provide a tailor made solution for every project.

DUDLEY ILLUSION FREESTANDA™



Legs are quickly and easily adjusted.

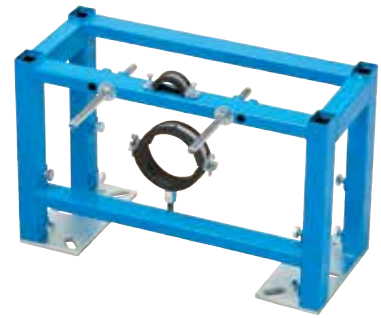

316233

USES

- Free-standing wall-hung WC pan support frame designed for use where no solid rear wall fixing is available.
- Can be used against flat walls and in corners.
- Ideal for most domestic and commercial applications.

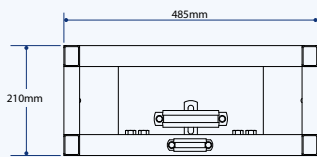

FEATURES

- Sturdy floor fixing brackets remove the need for rear wall fixing.
- Legs adjust to offer WC pan height fixing flexibility.
- Strong steel tubular section construction.

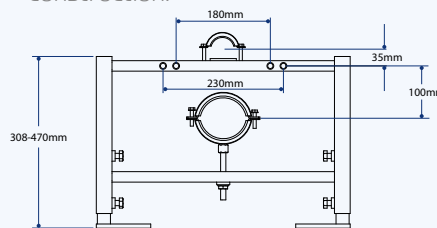

- Blue painted finish and zinc plated wall and floor brackets.
- Flushbend and WC pan connector clamps.
- Floor and WC pan fixing bolts included.

OPTIONS

- Can be installed in conjunction with all Dudley concealed cisterns to provide a tailor made solution for every project.

DUDLEY ILLUSION BIDET™



Reversible wall brackets can be fixed through 180°.

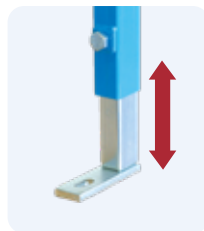

Legs are quickly and easily adjusted.



Floor brackets rotate through 360°.



314887

USES

- Wall-hung bidet support frame designed for use against flat walls and in corners.

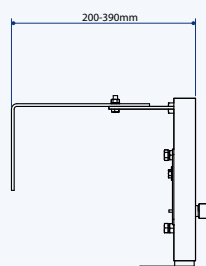
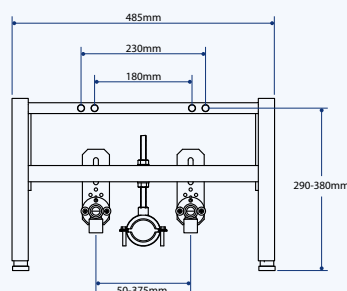

- Ideal for most domestic and commercial applications.

FEATURES

- Wall and floor fixing brackets can be fixed through 180 degrees and 360 degrees respectively to simplify installation.
- Legs adjust to offer bidet height fixing flexibility.
- Strong steel tubular section construction.
- Blue painted finish and zinc plated wall and floor brackets.
- Floor and bidet fixing bolts included.

DUDLEY ILLUSION BASIN™



Reversible wall brackets can be fixed through 180°

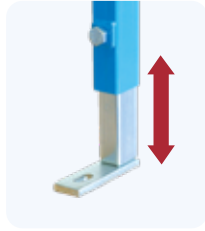

Legs are quickly and easily adjusted.

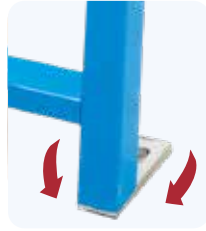

Floor brackets rotate through 360°.



319207

USES

- Wall-hung basin support frame designed for use against flat walls and in corners.
- Ideal for most domestic and commercial applications.

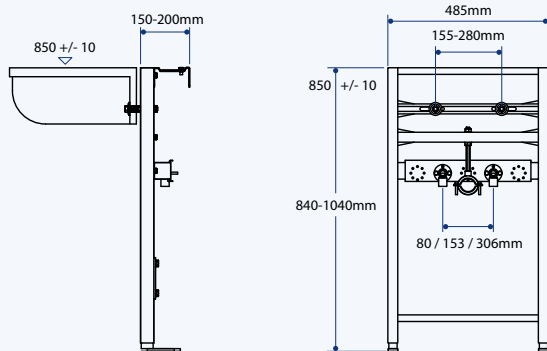

FEATURES

- Wall and floor fixing brackets can be fixed through 180 degrees and 360 degrees respectively to simplify installation.
- Legs adjust to offer basin height fixing flexibility.
- Strong steel tubular section construction.
- Blue painted finish and zinc plated wall and floor brackets.
- Floor and basin fixing bolts included.

DUDLEY ILLUSION SENTINEL™



Vertical slot provides pan height fixing flexibility.

USES

- Wall-hung WC pan support brackets.
- Ideal for most domestic and commercial applications.

FEATURES

- Strong cast iron construction.
- Vertical slot offers WC pan height fixing flexibility.
- Grey painted finish.
- Floor and WC pan fixing bolts available as optional extras.
- (Pair brackets) 317614
- (Fittings to fix WC pan to brackets) 318590

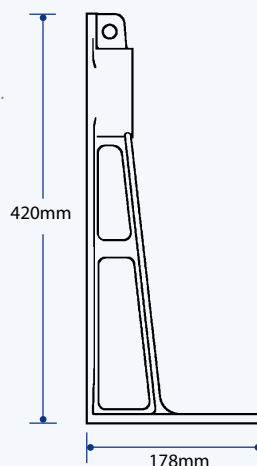

ELECTROFLO RANGE

Encompassing infra-red WC flushing, urinal controls and taps, the Electroflo range has been specifically developed to save water and maintain hygiene.

Electroflo products also help to integrate cutting edge technology and the latest contemporary styling into every application.

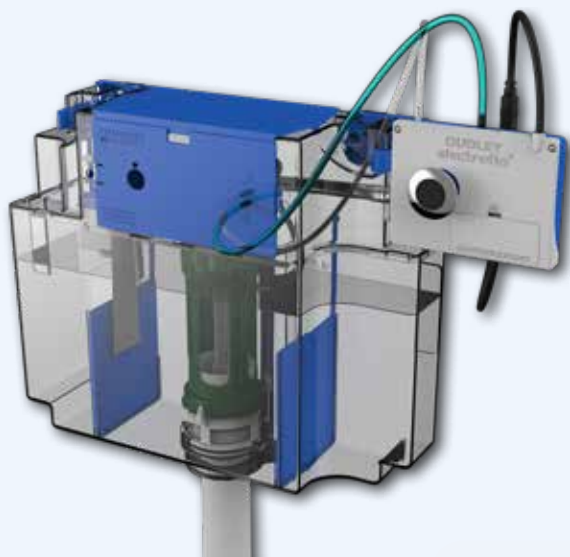

SAVING WATER

Offering WC flushing volumes as low as 2.6 litres, urinal controls and taps that deliver as little as 1 litre of water per use, the Electroflo range supports BREEAM and other water and energy saving initiatives.

SAVING TIME AND MONEY

Dudley Electroflo products are also simple to install and service in order to save both time and money on-site.

SPARES READILY AVAILABLE

Spares are readily available to help maximise the working life of every Dudley cistern.

Please see pages 68-73, visit spares.thomasdudley.co.uk or call us on 0121 530 7000 (Sales).

HYGIENIC OPERATIONS

All taps are programmed as standard to switch on automatically for a short period, if the tap has not been operated for more than a 24 hour period, to prevent dead legs.

Finding the perfect electronic product for every project.

	ELECTROFLO WC (PAGE 43-44)	ELECTROFLO URINAL CONTROLS (PAGE 45)	KINETIC (PAGE 46)	ELECTROFLO TAPS (PAGE 47-50)	ELECTROFLO CONTEMPORARY AND HORIZON SOAP DISPENSERS (PAGE 51)	ELECTROFLO AUTOMATIC HAND DRYERS (PAGE 51)
WC FLUSHING	.					
URINAL FLUSHING		.	.			
TAPS				.		
SOAP DISPENSERS					.	
HAND DRYERS						.

DUDLEY ELECTROFLO® WC FOR CONCEALED CISTERNS



Behind tiles.



Behind panelling.



In furniture.



Chrome plated sensor.



Stainless steel sensor.



USES

- Innovative electronic WC flushing system designed for use with Dudley Vantage and Miniflo concealed cisterns (pages 19-20) and Illusion A and V frames (pages 37-38).
- Ideal for use in bathroom furniture, behind tiles and partitioning and in most other domestic and commercial applications.
- The Electroflo can also be simply retrofitted to upgrade existing pushbutton or push plate operated Vantage cisterns and miniflo and royal pushflo cisterns.

FEATURES

- Discreet sensor provides water saving dualflush when a hand is held in front or waved across the sensor. This provides a hygienic touch-free solution.
- Sensor is also interactive and indicates when full or reduced flushes are being delivered and when the cistern is refilling.
- Sensor surround measures just 40mm in diameter and comes in an attractive chrome plated or stainless steel finish. A 100mm diameter commercial sensor surround with operating instructions is also available.

- Compact control box fits neatly onto the rear panel into which the sensor is installed.
- Powered by four 1.5V AA batteries (not included) or mains via a 240V transformer.
- 400mm long sensor cable plugs into the control box via a userfriendly adaptor.
- Spares are readily available.
- Low battery warning.

WATER-SAVING

- 6/4, 5/3 or 4/2.6 litre dualflush.
- Supports BREEAM.

OPTIONS

- Mains powered recommended for commercial installations.
- 40mm or 100mm diameter sensor surrounds.
- Extension kit for use with walls up to 170mm thick.
- Stainless steel sensor also available.

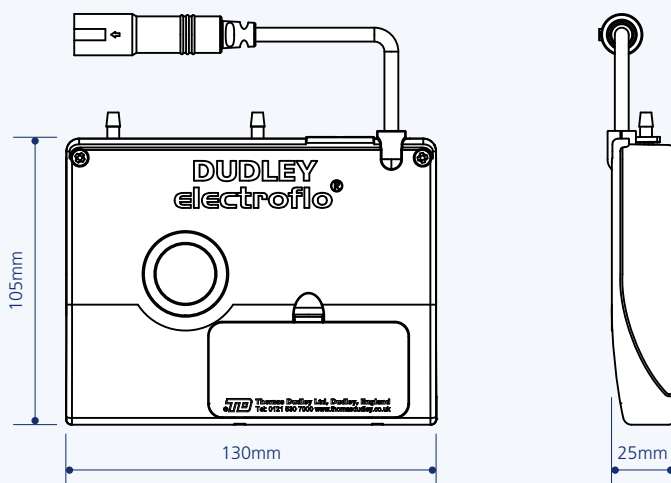

New junction box can be used to power up to 10 WC units from one mains input. This includes LED status indicators for each Electroflo WC unit.

DUDLEY ELECTROFLO® WC FOR CERAMIC CISTERNS

Innovative electronic WC flushing system that can be used to upgrade new or existing push button operated ceramic cisterns to electronic flushing.

Discreet infra-red sensor provides water-saving dualflush and sits neatly into the cistern lid. The control box fits into the cistern. Ideal for domestic applications.



Dudley electroflo urinal controls CP mains op - 323687

Dudley electroflo urinal controls CP battery op - 323686



DUDLEY ELECTROFLO® URINAL CONTROLS

Potential water savings that can be achieved using Electroflo Urinal Controls.

APPLICATION	AUTO SYPHON SYSTEM FLUSHING ALL URINALS 48 TIMES A DAY	ELECTROFLO URINAL INFRA-RED CONTROLS FLUSHING INDIVIDUAL URINALS AFTER USE
Commercial washroom (spreader run of three urinals being used 100 times per day):		
FLUSHES PER DAY	48	100
AVERAGE WATER USED PER FLUSH	12 LITRES	1 LITRE
TOTAL WATER USED PER YEAR	210,240 LITRES	36,500 LITRES
ANNUAL WATER SAVING		173,740 LITRES
ANNUAL FINANCIAL SAVING (based on estimated metered charges at September 2011)		£305.31

DUDLEY ELECTROFLO® URINAL CONTROLS

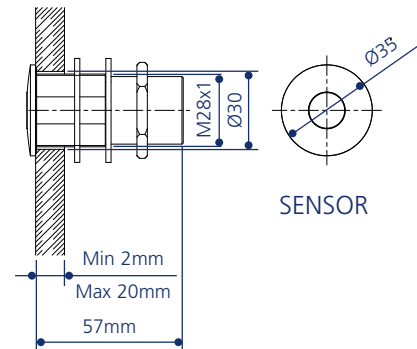

Sensor

DC Pipe interrupter
327995

SENSOR

USES

- Electroflo electronic urinal controls sit neatly above the urinal bowl and can be used with confidence in most commercial applications.

FEATURES

- Infra-red sensor flushes each urinal after use.
- Flushing is activated when the user has moved away from the urinal.
- Flushing time can be adjusted from 3-20 seconds.
- Suitable for pressures of 0.3- 8.0 bar.

- Sensor is supplied with a solenoid valve.
- Sensor has a range of 55cm and is adjustable.
- Hygiene flush every 24 hours.
- Sensor and sensor plates come with 15mm pushfit connector and 1/2" BSP connectors respectively and can be easily installed into partitioning materials and tiles.
- Spares are readily available.
- DC pipe interrupter is available to prevent category 5 bacteria contaminating the mains water supply.

WATER-SAVING

- Deliver as little as 1 litre of water per flush to deliver significant savings compared with traditional petcocks.
- Supports BREEAM.

OPTIONS

- 35mm diameter sensor surround or choice of sensor plates.
- 9V externally mounted battery or mains powered.
- Sensors available in polished chrome and stainless steel effect finishes.

DUDLEY KINETIC®

Introducing Kinetic - the new, intelligent IRC urinal flushing control. Attractively styled, and multi-functional, Kinetic offers exceptional reliability and a simple set-up solution.

Kinetic is an “all-in-one” electronic control, designed to save time and guarantee accurate water-savings in commercial washroom installations



New in-line filter feature



Solenoid can be installed next to or remotely from control box



Simple set up via user-friendly buttons and wizard



Control box, solenoid and ceiling mounting kit supplied

USES

- Kinetic is ideal for use with automatic cisterns and multiple station urinals.

FEATURES

- Can be easily installed into pipework, wall or ceiling mounted applications.
- Supplied with an aesthetically pleasing flush mounting kit.
- Each unit can be powered by mains, 4 x AA batteries or mains with battery back-up (batteries not included).
- Control box can be installed remotely from the solenoid and is supplied as standard with a 1m cable.

- Passive infrared sensor detects user movement. After a pre-set time, the solenoid valve allows water to fill the cistern and deliver a flush.
- 6L/M.
- Suitable for water pressures ranging from 0.1 bar to 10 bar.
- Quick and simple set up via user-friendly buttons and intuitive software.
- Hygiene and economy flushing modes can also be quickly configured to customer requirements.
- Tamper proof design and chrome fittings are conveniently included.
- WRAS approved

- Control box dimensions: 118mm(h) x 118mm(w) x 33mm(d)
- Solenoid box dimensions: 98mm(h) x 100mm(w) x 50mm(d)
- Can be serviced without removing the Kinetic controller and opening the Kinetic valve

WATER-SAVING

- Regulates flushing based on actual washroom usage to save up to 80% of water when compared to traditional systems.

OPTIONS

- Available in glossy white and grey finishes. White control box and grey solenoid combination also available.

DUDLEY ELECTROFLO® TAPS

Potential water savings that can be achieved using Electroflo Taps.

APPLICATION	TRADITIONAL MIXER TAP	ELECTROFLO CURVE INFRA-RED TAP	ELECTROFLO CURVE INFRA-RED TAP WITH AERATOR
DOMESTIC BATHROOMS (BASED ON FAMILY OF 4 EACH USING TAP 6 TIMES PER DAY):			
USES PER DAY	24	24	24
AVERAGE WATER USED PER VISIT	9 LITRES	3 LITRES	1 LITRE
TOTAL WATER USED PER YEAR	78,840 LITRES	26,280 LITRES	8,760 LITRES
ANNUAL WATER SAVING		52,560 LITRES	70,080 LITRES
ANNUAL FINANCIAL SAVING (BASED ON ESTIMATED METERED CHARGES AT SEPTEMBER 2011)		£94.61	£126.83
COMMERCIAL WASHROOM (BASED ON EACH TAP BEING USED 100 TIMES PER DAY):			
USES PER DAY	100	100	100
AVERAGE WATER USED PER VISIT	9 LITRES	3 LITRES	1 LITRE
TOTAL WATER USED PER YEAR	328,500 LITRES	109,500 LITRES	36,500 LITRES
ANNUAL WATER SAVING		219,000 LITRES	292,000 LITRES
ANNUAL FINANCIAL SAVING (BASED ON ESTIMATED METERED CHARGES AT SEPTEMBER 2011)		£384.85	£513.13

DUDLEY ELECTROFLO® CONTEMPORARY™

USES

- Vanity top/basin mounted electronic tap that is ideal for use in most domestic and commercial applications.

FEATURES

- Stylish tubular design.
- Hygienic touch-free operation.
- Delivers cold or premixed warm water.
- Shuts off when hand is removed from in front of sensor. Water delivery automatically stops after 90 seconds (can be adjusted).
- Robust one piece brass body and vandal-resistant design.
- ½" BSP connection.
- Must be installed with a thermostatic mixing valve for premixed water.
- Suitable for pressures of 0.5- 8.0 bar. 8.0 bar + with a flow restrictor.
- 50mm- 300mm sensor range.
- Maximum temperature 70°C.
- 6ltr per minute flow rate - others available.

WATER-SAVING

- Delivers as little as 1 litre of water per visit.
- Supports BREEAM.

OPTIONS

- 9V externally mounted battery or mains/transformer powered.
- Attractive chrome plated, stainless steel or black finishes are available.



Chrome plated



Stainless steel effect



Matt Black

- Battery polished chrome 323680
- Mains polished chrome 323681
- Manual mix battery polished chrome 323904
- Mains stainless steel effect 327965
- Mains black 327966

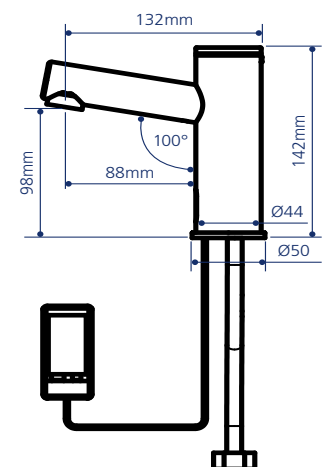

MANUAL MIX OPTION AVAILABLE
(THERMOSTATIC MIXING VALVE NOT REQUIRED)

DUDLEY ELECTROFLO® AVANTI™



FEATURES

- Sleek minimalist design.
- Hygienic touch-free operation.
- Delivers cold or premixed warm water.
- Shuts off when hand is removed from in front of the sensor. Water delivery automatically stops after 90 seconds (can be adjusted).
- Robust one piece brass body and vandal-resistant design.
- 15mm pushfit connection.
- Must be installed with a thermostatic mixing valve for premixed water.
- Suitable for pressures of 0.5 - 8.0 bar. 8.0 bar + with a flow restrictor.
- 50mm - 300mm sensor range.
- Maximum temperature 70°.
- 6 litre per minute flow rate - others available.

WATER SAVING

- Delivering as little as 1 litre of water per visit.
- Supports BREEAM

OPTIONS

- 9V externally mounted battery or mains/transformer powered
- Attractive chrome plated and stainless steel effect finishes are available.



Chrome plated



Stainless steel effect

Only available when large quantities are required - please enquire

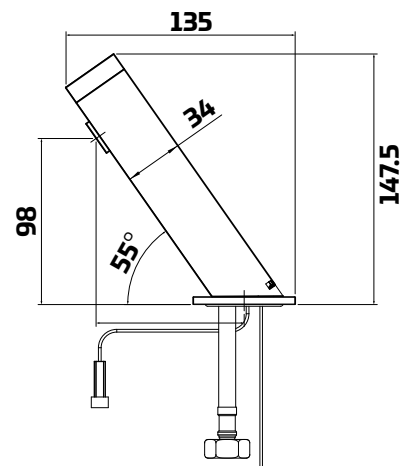

DUDLEY ELECTROFLO® LINEAR™

USES

- Vanity top/basin mounted electronic tap that is ideal for use in most domestic and commercial applications.

FEATURES

- Sleek minimalist design.
- Hygienic touch-free operation.
- Delivers cold or premixed warm water.
- Shuts off when hand is removed from in front of sensor. Water delivery automatically stops after 90 seconds (can be adjusted).
- Robust one piece brass body and vandal-resistant design.
- 15mm pushfit connection.
- Must be installed with a thermostatic mixing valve for premixed water.
- Suitable for pressures of 0.5- 8.0 bar. 8.0 bar + with a flow restrictor.
- 50mm- 300mm sensor range.

- Maximum temperature 70°C.
- 6ltr per minute flow rate - others available.

WATER-SAVING

- Delivers as little as 1 litre of water per visit.
- Supports BREEAM.

OPTIONS

- 9V externally mounted battery or mains/transformer powered.
- Attractive chrome plated or stainless steel finish are available.
- Battery polished chrome 323684
- Mains polished chrome 323685
- Mains stainless steel effect 327967



Chrome plated



Stainless steel effect

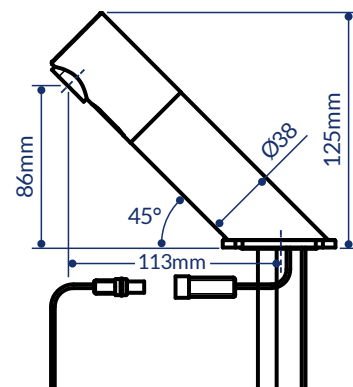

DUDLEY ELECTROFLO® CURVE™

USES

- Vanity top/basin mounted electronic tap that is ideal for use in most domestic and commercial applications.

FEATURES

- Classic swan neck design.
- Hygienic touch-free operation.
- Delivers cold or premixed warm water.
- Shuts off when hand is removed from in front of sensor. Water delivery automatically stops after 90 seconds (can be adjusted).
- Robust one piece brass body and vandal-resistant design.
- Attractive chrome plated finish.
- ½" BSP connection.
- Must be installed with a thermostatic mixing valve for premixed water.

- Suitable for pressures of 0.5- 8.0 bar. 8.0 bar + with a flow restrictor.
- 50mm- 300mm sensor range.
- Maximum temperature 70°C.
- 6ltr per minute flow rate - others available.

WATER-SAVING

- Delivers as little as 1 litre of water per visit.
- Supports BREEAM.

OPTIONS

- 9V externally mounted battery or mains/transformer powered.
- Battery polished chrome 323676
- Mains polished chrome 323677
- Manual mix battery polished chrome 323903
- Manual mix mains polished chrome 324485

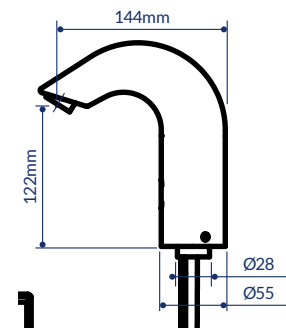

MANUAL MIX OPTION AVAILABLE
(THERMOSTATIC MIXING VALVE NOT REQUIRED)

DUDLEY ELECTROFLO® ARC™

USES

- Vanity top/basin mounted electronic tap that is ideal for use in most domestic and commercial applications.

FEATURES

- Classic swan neck design.
- Hygienic touch-free operation.
- Delivers cold or premixed warm water.
- Shuts off when hand is removed from in front of the sensor.
- Water delivery automatically stops after 90 seconds (can be adjusted).
- Robust one piece brass body and vandal-resistant design.
- Attractive chrome plated finish.
- ½" BSP connection.
- Must be installed with a thermostatic mixing valve for premixed water.

- Suitable for pressures of 0.5- 8.0 bar. 8.0 bar + with a flow restrictor.
- 50mm - 300mm sensor range
- Maximum temperature 70°
- 6 litre per minute flow rate - others available.

WATER SAVING

- Delivering as little as 1 ltr of water per visit.
- Supports BREEAM.

OPTIONS

- 9V externally mounted battery or mains/transformer powered.
- Manual mix option available (thermostatic mixing valve not required).
- Attractive chrome plated and stainless steel effect finishes are available.

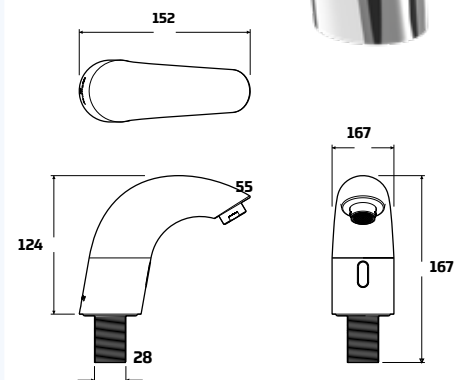

Chrome plated

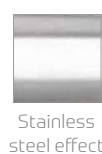

Stainless steel effect

Only available when large quantities are required - please enquire

DUDLEY ELECTROFLO® HORIZON™

USES

- Wall mounted electronic tap that is ideal for use in most domestic and commercial applications.

FEATURES

- Minimalistic styling.
- Hygienic touch-free operation.
- Delivers cold or premixed warm water.
- Shuts off when hand is removed from in front of sensor. Water delivery is adjustable.
- Robust one piece brass body and vandal-resistant design.
- ½" BSP connection.
- Must be installed with a thermostatic mixing valve for premixed water.
- Suitable for pressures of 0.5- 8.0 bar. 8.0 bar + with a flow restrictor.
- 50mm-300mm sensor range*.

- Max temperature 70°C
- 6ltr per minute flow rate - others available.

WATER-SAVING

- Delivers as little as 1 litre of water per visit.
- Supports BREEAM.

OPTIONS

- 6 x 1.5V AA externally mounted batteries or mains/transformer powered.
- Attractive chrome plated, stainless steel or black finishes are available.
- Battery polished chrome 324328
- Mains polished chrome 324329
- Main stained steel effect 327968
- Mains black 327969

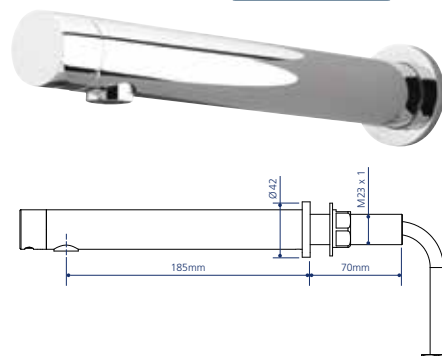

* To prevent reflection problems, it is recommended to maintain a minimum distance of 300mm between the sensor and the bottom of the basin.



Chrome plated



Stainless steel effect



Matt Black

DUDLEY ELECTROFLO® HYGIENE™

USES

- Wall mounted electronic tap that is ideal for use in most domestic and commercial applications.

FEATURES

- Minimalistic styling.
- Design aids after use drainage to prevent water borne bacteria.
- Hygienic touch-free operation.
- Delivers cold or premixed warm water.
- Shuts off when hand is removed from in front of sensor. Water delivery is adjustable.
- Robust one piece brass body and vandal-resistant design.
- 15mm pushfit connection.
- Must be installed with a thermostatic mixing valve for premixed water.
- Suitable for pressures of 0.5- 8.0 bar. 8.0 bar + with a flow restrictor.

- 50mm- 300mm sensor range*.
- Maximum temperature 70°C.
- 6ltr per minute flow rate - others available.

WATER-SAVING

- Delivers as little as 1 litre of water per visit.
- Supports BREEAM.

OPTIONS

- 6 x 1.5V AA externally mounted batteries or mains/transformer powered.
- Attractive chrome plated or stainless steel finishes are available.
- Battery polished chrome 323682
- Mains polished chrome 323683
- Manual stained steel effect 327970

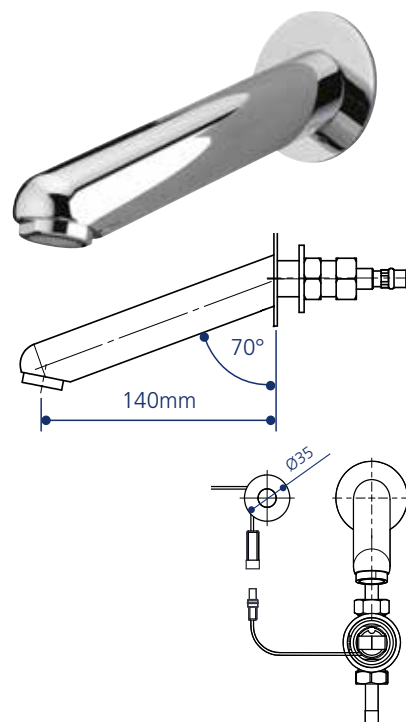

Chrome plated



Stainless steel effect



Matt Black

DUDLEY ELECTROFLO® CONTEMPORARY SOAP DISPENSER™

USES

- Vanity top/basin mounted electronic dispenser for use with liquid soaps and anti-bacterial gels.

FEATURES

- Stylish tubular design.
- Hygienic touch-free operation.
- Robust brass body.
- Attractive chrome plated, stainless steel or black finishes are available.
- ½" BSP connection.
- 1 litre capacity.
- Can be used with soap viscosity of 100-3800 cps.
- 50mm-300mm sensor range.
- Battery polished chrome 326437
- Mains polished chrome 324327
- Mains stainless steel effect 327974
- Mains black 327975

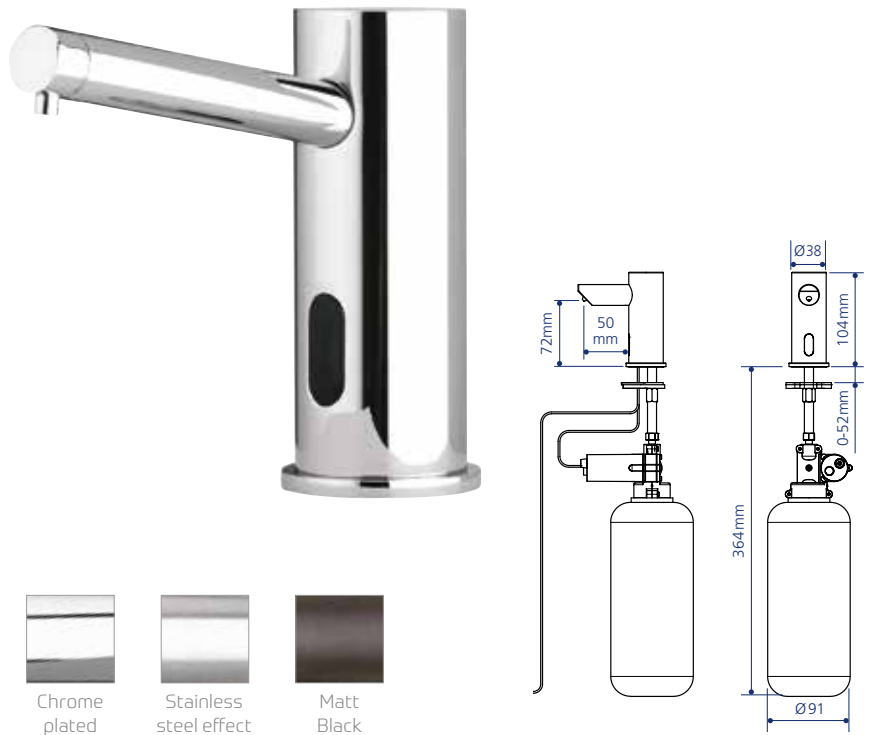

DUDLEY ELECTROFLO® HORIZON SOAP DISPENSER™

USES

- Vanity top/basin mounted electronic dispenser for use with liquid soaps and anti-bacterial gels.

FEATURES

- Minimalistic design.
- Hygienic touch-free operation.
- Robust brass body.
- Attractive chrome plated, stainless steel or black finishes are available.
- ½" BSP connection.
- 1 litre capacity.
- Can be used with soap viscosity of 100-3800 cps.
- 50mm-300mm sensor range.
- Battery polished chrome 325424
- Mains polished chrome 325423
- Mains stainless steel effect 327976
- Mains black 327977

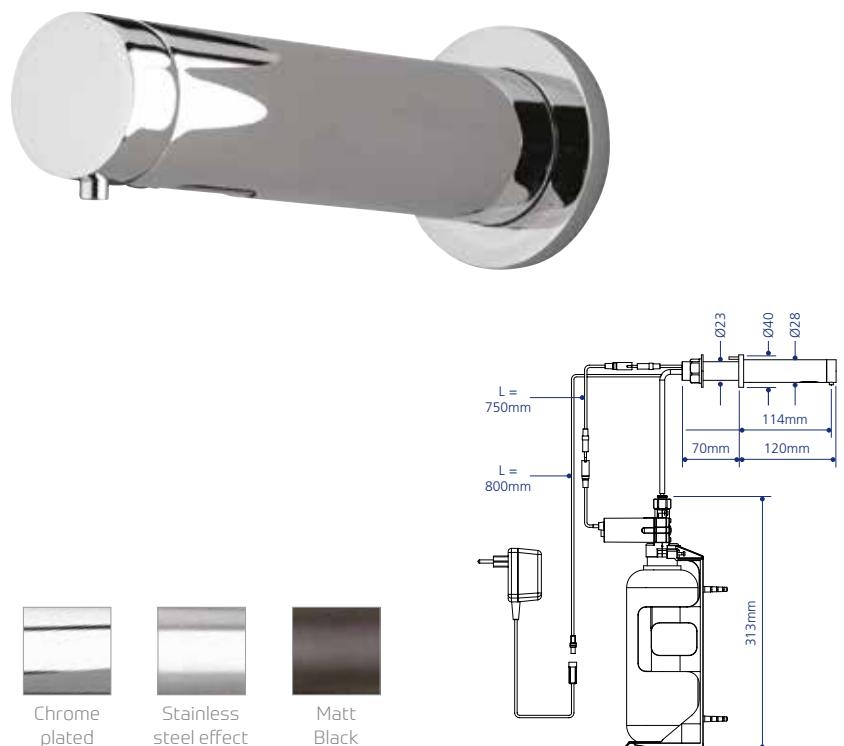

DUDLEY THERMOSTATIC MIXING VALVE

Our new thermostatic mixing valves meet the requirements of BS7942: 2000 and NHS D08. They are WRAS and Buildcert approved, TMV 2 and TMV 3 certified and are perfect for use with Dudley Electroflo taps. Can be used with pressures from 0.2 -10 bar. Maximum temperature of water delivered can be adjusted from 30°C - 50°C. Help to prevent legionella by cooling water at the point of delivery.



324551 15mm
324552 22mm

USES

- Perfect for use with Electroflo and other pre-mixed taps.
- TMV 2 and TMV 3 certified.

FEATURES

- Meets requirements of BS7942: 2000 and NHS D08.
- WRAS and Buildcert approved.
- Can be used with pressures of 0.2 -10 bar.
- Delivers water between 30° and 50°.
- Integral check valves and filters.
- 15mm and 22mm sizes.

DUDLEY TAP JUNCTION BOX

- Perfect for powering up to 10 taps.
- Two and three way male to female and female to male power splitters available.



323691

DUDLEY ELECTROFLO® WC JUNCTION BOX

- Can power up to 10 Electroflo WC Units.
- Comes with 3.3m connection cables.

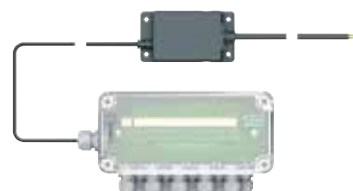

323691

DUDLEY REMOTE CONTROL HANDSET

- Allows same settings to be quickly applied to multiple individual taps.



323690 Taps
327987 Soap dispensers



RESAN RANGE

The new Dudley Resan range of sanitaryware and accessories provides an extremely reliable damage resistant solution in every application.

Resan WC pans, basins, urinals, shelves and mirror frames are all made to withstand the hardest of treatment in prisons, detention centres, hotels, night clubs, sports stadia and other public areas where there may be the potential for vandalism.

Engineered using an advanced polymer resin material, they are shatterproof, exceptionally durable, chemical resistant and offer an aesthetically pleasing alternative to stainless steel.

SAVING WATER

Resan WC pans can be installed in conjunction with Dudley concealed cisterns to offer flush volumes down to 6/4 litres to support BREEAM and other initiatives.



DUDLEY RESAN® WC PAN

- Damage-resistant and anti ligature.
- Back to wall design is perfect for use with concealed cisterns that can be safely hidden out of reach behind panelling and walls.
- Integral moulded seat removes the threat of damage and unwanted removal.
- Available in easy clean matt and gloss finishes.
- Can be installed in conjunction with water saving dualflush concealed cisterns that support BREEAM and other initiatives.
- WC pans can also be engineered to customer specifications - please enquire.
- The flush can be activated with pushbutton, pushplate, lever, piezo (light touch) or electronically operated concealed cisterns.
- A WC pan designed to cater for the less able is also available. This is 60mm higher and protrudes further from the back wall for easy access.
- The WC pan is also available in a blue rim for the purposes of aiding the visually impaired or dementia sufferers with normalising their environment, promoting confidence and ease of location.
- Corner and Doc M WC pans can also be supplied. In addition, WC pans can be engineered to customer specifications – please enquire.

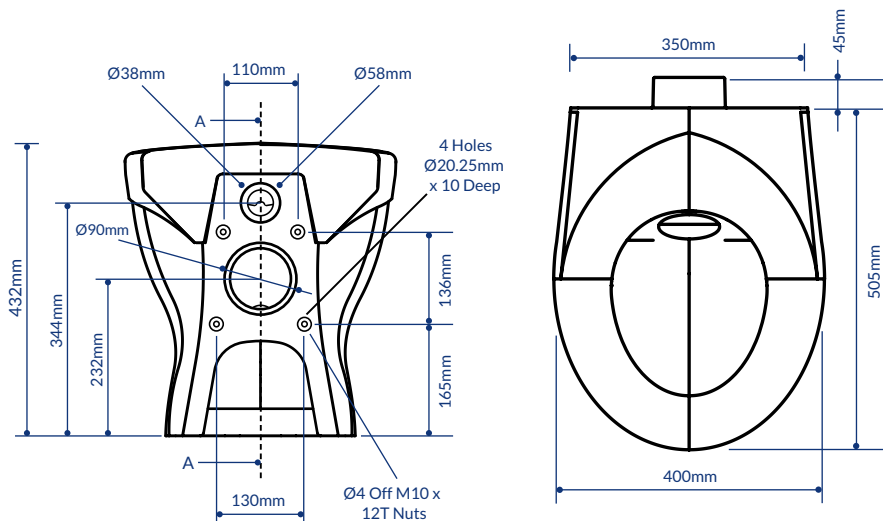

Seat option



Less abled option



Fixed floor option

DUDLEY MINIFLO® CONCEALED CISTERN 322950

- Factory pre-assembled for quick and easy installation.
- One piece wall fixing bracket.
- Dual or single flush options.
- Supports BREEAM.
- WRAS approved.
- Compatible with pneumatic, light touch (piezo), electronic and Dudley Electroflo controls.



DUDLEY SAFEFLO™ WC PNEUMATIC CONTROL 326187

- Single or dual flush operation.
- Secure, anti-ligature through the wall design for wall thicknesses to 175mm (stainless steel).



DUDLEY WC TOUCHPAD SINGLE/DUAL FLUSH CONTROL 326177

- Single or dual flush push button activation.
- Secure, anti-ligature through the wall installation.
- Wall thickness up to 165mm.
- Must be installed with 326179 and 326171.



DUDLEY WC INFRA-RED SINGLE/DUAL FLUSH CONTROL 326178

- Single or dual flush touch-free activation.
- Secure, anti-ligature through the wall design.
- Must be installed with 326179 and 326171.



DUDLEY 1" DIRECT FLUSH VALVE WITH VACUUM BREAKER 326179

- For use with 326177 and 326178.



DUDLEY SECURE CELL 8 WAY ELECTRONIC CONTROL BOX 326171

- For use with touchpad or infra-red system.
- Reduces costs by removing the need for separate units.
- Optional security lock out facility.
- Coordinates the performance of washbasin, shower and WC controls.



DUDLEY RESAN® BASINS

- Damage-resistant and anti-ligature.
- Water-saving dual and single spout designs available.
- Light touch or non touch activation.
- Back to wall design allows pipework to be safely hidden away.
- Available in easy clean matt and gloss finishes.
- Basins can also be engineered to customers specifications – please enquire.
- Outlet holes can be configured subject to order.



Dual hole

326684



Oval basin bracket

333413

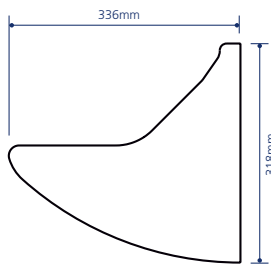

Single hole

325324



Oval

330813

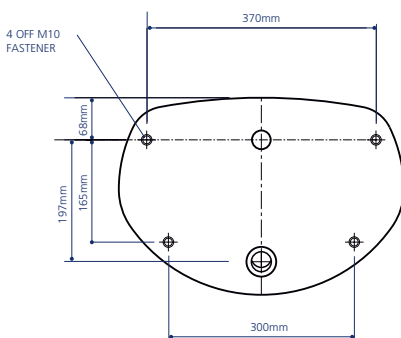
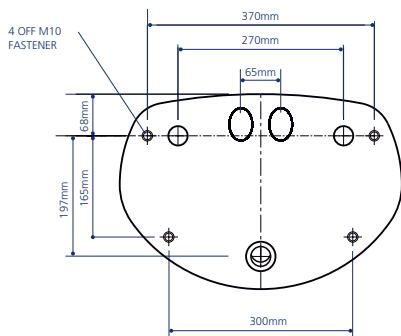

No hole

326717



Rectangular

330812

DUDLEY SAFEFLO™ PNEUMATIC WASHBASIN CONTROL 326185

- Damage-resistant and anti-ligature through the wall control.
- Flow rate pre-set at 6lpm at 3 bar.
- Fittings in stainless steel with colour coded anodised red and blue markers.



DUDLEY ELECTRONIC SECURE WASHBASIN CONTROL 326175/326176

- Anti-ligature through walls up to 165mm thick with chrome plated wall plate.
- Light touch or infra-red activation.
- Colour coded markers.
- 326172 and 326173 both have to be installed with 326174, 326175, 326176 and 326171.



DUDLEY SECURE CELL 8 WAY ELECTRONIC CONTROL BOX 326171

- For use with touchpad or infra-red system.
- Reduces costs by removing the need for separate units.
- Optional lock out facility.
- Coordinates the performance of washbasin, shower and WC controls.



DUDLEY ELECTROFLO® HORIZON INFRA-RED TAP 324329

- Touch-free mixer tap for use with single spout basin



DUDLEY ELECTROFLO® HYGIENE INFRA-RED TAP 323683

- Touch-free mixer tap for use with single spout basin.



DUDLEY RESAN® URINALS

- Damage-resistant and anti-ligature.
- Back to wall design allows all connections to be safely hidden away.
- Available in easy clean matt and gloss finishes.
- Urinals can also be engineered to customer specifications – please enquire.
- Can be supplied with an antibacterial agent as an optional extra. This is proven to improve hygiene by reducing the potential for micro-organisms to reproduce in between cleanings.

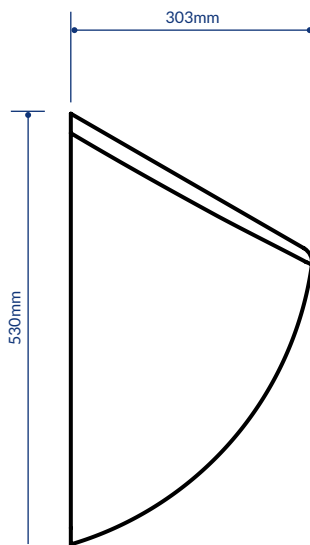
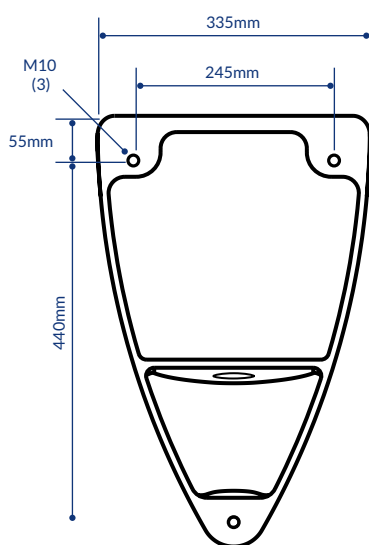

COMPREHENSIVE RANGE OF ACCESSORIES AVAILABLE;



Urinal spreader
328038



Urinal trap
328039



Urinal Waste
328037

DUDLEY LIGHT TOUCH URINAL CONTROLS

326172



- Dudley light touch urinal control with 4m cable.
- Anti-ligature through walls up to 150mm thick.
- Chrome plated wall plate.
- Light touch activation.
- Must be installed with 326174 and 326171.

DUDLEY INFRA-RED URINAL CONTROLS

326173



- Dudley infra-red urinal control with 4m cable.
- Anti-ligature through walls up to 170mm thick.
- Chrome plated wall plate.
- Hygienic touch-free activation.
- Must be installed with 326174 and 326171.

DUDLEY 8 WAY CONTROL BOX

326171



- Dudley 8 way control box for up to 8 points of use.
- Reduces costs by removing the need for separate units.
- Anti-blocking security prevents abuse or waste.
- Dualflush option.
- Time flow selectable at 7, 15, 30 or 45 seconds.

DUDLEY SOLENOID VALVE

326174



- 1/2" solenoid valve with 4m cable (12v).

DUDLEY SAFEFLO™ THROUGH THE WALL SHOWER CONTROL SET

326186

- Anti ligature push button control.
- Automatic shut off (adjustable).
- Pre-set flow rate at 8 lmp at 3 bar. (A thermostatic mixing valve to provide safe temperature controlled hot water).



DUDLEY SOLENOID VALVE

326174

- 1/2" solenoid valve with 4m cable (12v).



DUDLEY ANTI-LIGATURE WALL MOUNTED SHOWER HEAD

326183

- Chrome plated brass body.
- Vandal proof fixing.
- Through wall fixing up to 230mm thick.



DUDLEY ANTI-LIGATURE CEILING MOUNTED SHOWER HEAD

326184

- Vandal proof.
- Ceiling mounted.
- Stainless steel finish 140mm cover plate.



DUDLEY 8 WAY CONTROL BOX

326171

- Dudley 8 way control box for up to 8 points of use.
- Reduces costs by removing the need for separate units.
- Anti-blocking security prevents abuse or waste.
- Dualflush option.
- Time flow selectable at 7, 15, 30 or 45 seconds.

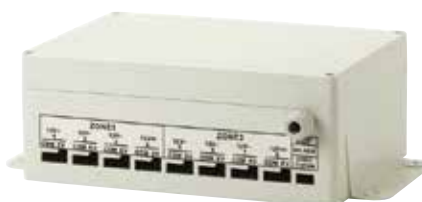

DUDLEY RESAN® ANTI-LIGATURE MIRRORS

- Damage-resistant.
- Ideal for creating safe and secure cell environments.
- Available in easy clean matt and gloss finishes.

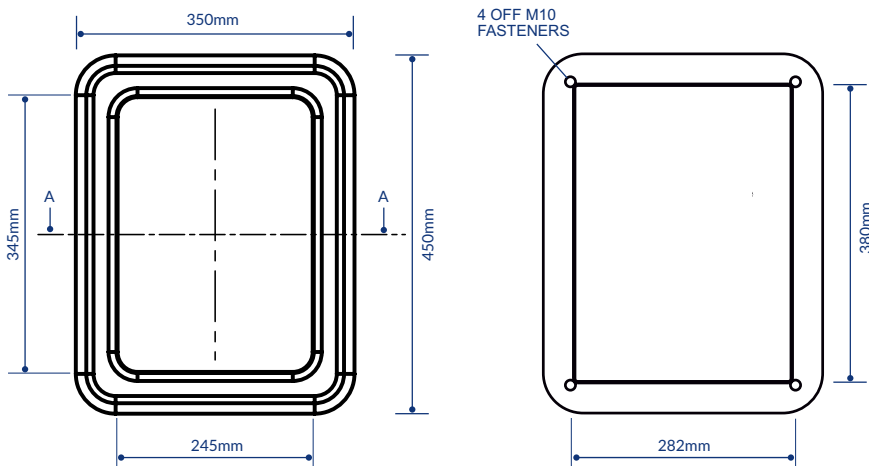

326147

DUDLEY RESAN® ANTI-LIGATURE SHELVES

- Damage-resistant.
- Ideal for creating safe and secure cell environments.
- Available in easy clean matt and gloss finishes.



326144

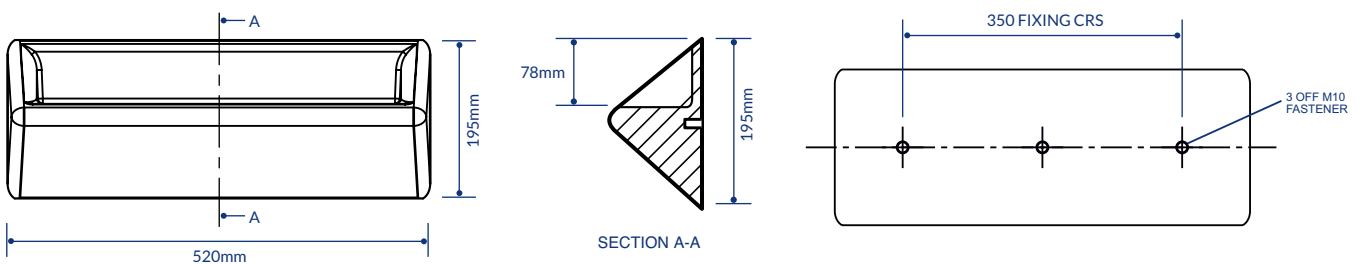

Please refer to actual product instructions for fixing points.



TOILET SEATS

Dudley toilet seats can be used with confidence in domestic and commercial applications.

They are made from proven thermoplastic and thermoset materials, undergo exhaustive testing and come with a two year guarantee.

EASY FIT HINGES

Easy-fit hinges are fitted in seconds by allowing the nut to slide over the thread to require only a few turns to tighten.

Aesthetically pleasing scratch-resistant glossy surfaces and durable rubber buffers also help to maximise the working life of every seat.

SPARES READILY AVAILABLE

Spare hinges are readily available.

Please see page 67.



Adjustable, easy-fit hinges suit most WC pans & are installed in seconds.



Durable rubber lid & seat buffers.



Durable material & construction.



Soft-close action.

THERMOSET SEATS

DUDLEY CELINE™

- Soft closing action
- Anti-bacterial
- Heavy-duty 2.3Kg seat
- Available in glossy white
- Rubber seat and cover buffers
- Easy-clean surface

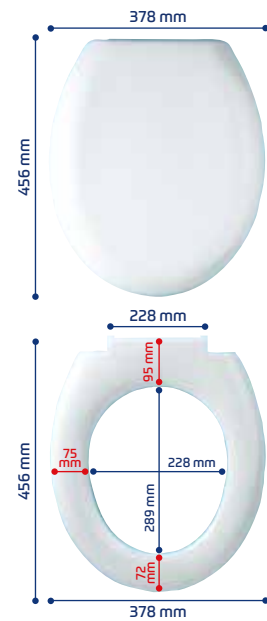

DUDLEY ARIANNE™

- Heavy-duty 2.3Kg seat
- Available in glossy white
- Rubber seat and cover buffers
- Easy-clean surface
- Top fix hinges available as an optional extra (Code 320913)

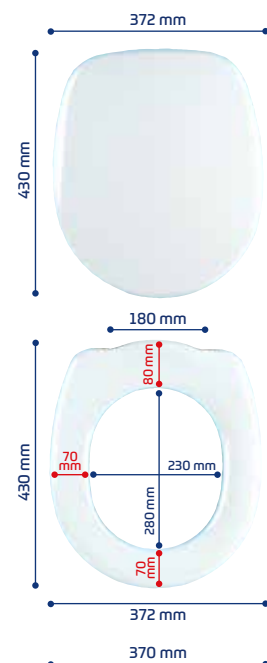

THERMOSET SEATS

DUDLEY EVE™

- Medium-duty 1.55Kg seat
- Available in glossy white
- Rubber seat and cover buffers
- Easy-clean surface
- Top fix hinges available as an optional extra (Code 320913)



**EASY-FIT
ADJUSTABLE**
STAINLESS STEEL
HINGES

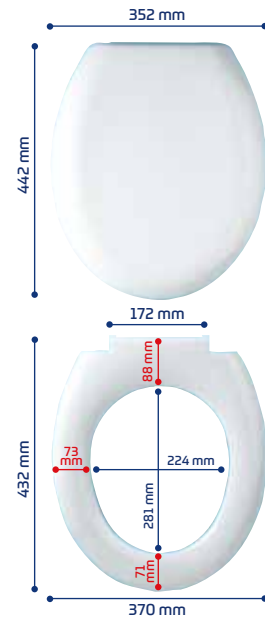

DUDLEY FRANCESCA™

- Heavy-duty 2.5Kg seat
- Available in glossy white
- Rubber seat and cover buffers
- Easy-clean surface
- Top fix hinges available as an optional extra (Code 320913)



**EASY-FIT
ADJUSTABLE**
STAINLESS STEEL
HINGES

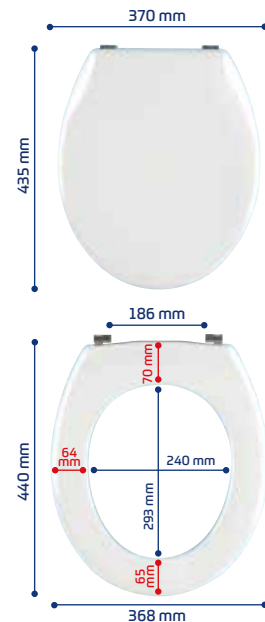

DUDLEY NADIA™

- Heavy-duty 2.2Kg seat
- Wrap-over style cover
- Available in glossy white
- Rubber seat and cover buffers
- Easy-clean surface
- Top fix hinges available as an optional extra (Code 320913)



**EASY-FIT
ADJUSTABLE**
STAINLESS STEEL
HINGES

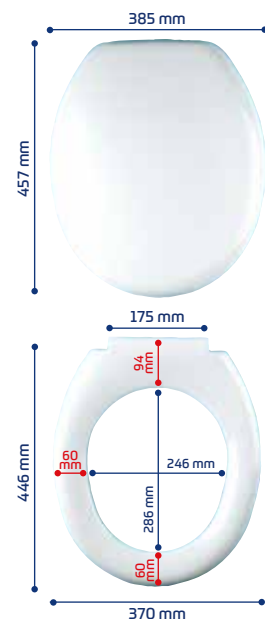

THERMOSET SEATS

DUDLEY TAMARA™

- Heavy-duty 2.3Kg seat
- Available in glossy white
- Rubber seat and cover buffers
- Easy-clean surface
- Top fix hinges available as an optional extra (Code 320913)
- Seat code 320726

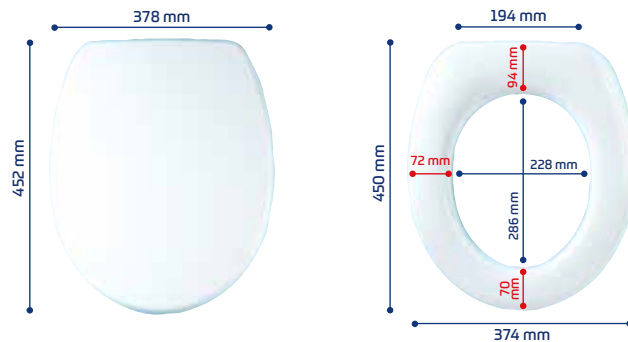

DUDLEY RHIANNA™

- Soft closing action available as an optional extra
- Heavy duty 2.0kg seat
- Available in glossy white
- Rubber seat and buffer covers
- Easy-clean surface
- Stainless steel lift-off hinges
- Anti bacterial available as an optional extra
- Top fix hinges available as an optional extra (Code 323745)
- Stainless steel hinges: Code 323331
- Seat code 323331

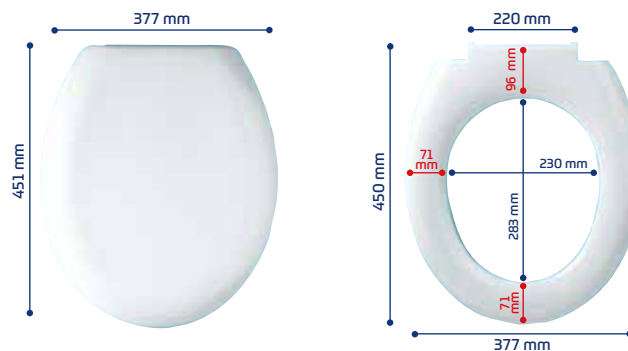

DUDLEY ESME™

- Soft closing action
- Heavy duty 2.0kg seat
- Available in glossy white
- Rubber seat and buffer covers
- Easy-clean surface
- Stainless steel lift-off hinges
- Anti bacterial available as an optional extra
- Top fix hinges available as an optional extra
- Seat code (bottom fix and hinges) 323329
- Seat code (top fix and hinges) 323925
- For adjustable bottom fix stainless steel hinges please enquire

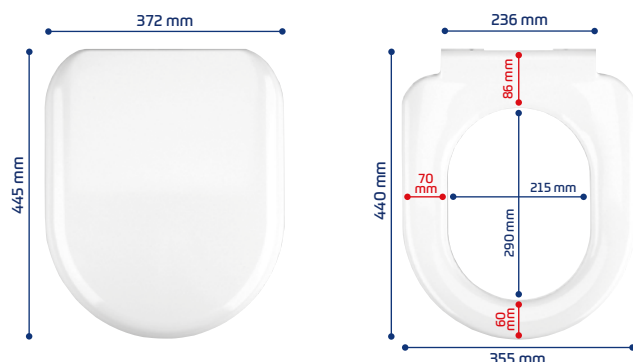

THERMOPLASTIC SEATS

DUDLEY AMELIA™

- Medium-duty 1.2Kg seat
- Wrap-over style cover
- Available in glossy white & black
- Rubber seat and cover buffers
- Easy-clean surface



Seat code: 320730 (White)
320731 (Black)

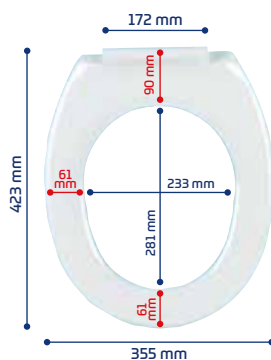
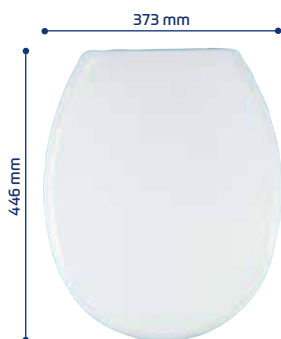

DUDLEY DANIELLE™

- Medium-duty 1.65Kg seat
- Available in glossy white
- Rubber seat and cover buffers
- Easy-clean surface

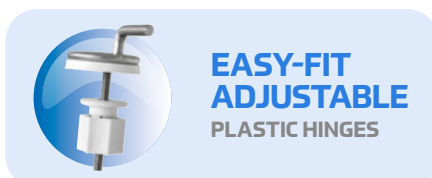

Seat code: 320732

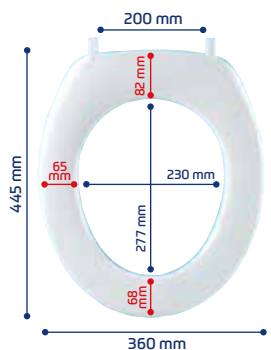
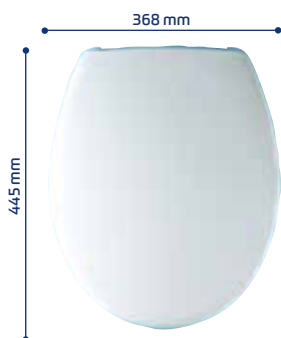

TOILET SEAT EXTRAS

CODE	THERMOSET SEATS
320723	WHITE CELINE SEAT (WITH SOFT-CLOSE, STAINLESS STEEL HINGES)
320728	WHITE ARIANNE SEAT (WITH ADJUSTABLE STAINLESS STEEL HINGES)
320725	WHITE EVE SEAT (WITH ADJUSTABLE STAINLESS STEEL HINGES)
320727	WHITE FRANCESCA SEAT (WITH ADJUSTABLE STAINLESS STEEL HINGES)
320729	WHITE NADIA SEAT (WITH ADJUSTABLE STAINLESS STEEL HINGES)
320726	WHITE TAMARA SEAT (WITH ADJUSTABLE STAINLESS STEEL HINGES)
323331	WHITE RHIANNA SEAT (WITH STAINLESS STEEL HINGES)
323925	WHITE ESME SEAT (WITH SOFT-CLOSE STAINLESS STEEL HINGES)







CODE	EXTRAS
320913	TOP FIX HINGES FOR ARIANNE, EVE, FRANCESCA, NADIA & TAMARA SEATS

CODE	THERMOPLASTIC SEATS
320730	WHITE AMELIA SEAT (WITH ADJUSTABLE PLASTIC HINGES)
320731	BLACK AMELIA SEAT (WITH ADJUSTABLE PLASTIC HINGES)
320732	WHITE DANIELLE SEAT (WITH ADJUSTABLE PLASTIC HINGES)









CODE	REPLACEMENT HINGES
320914	SOFT-CLOSE STAINLESS STEEL FOR CELINE SEAT
320911	ADJUSTABLE STAINLESS STEEL FOR ARIANNE, EVE, NADIA & TAMARA SEATS
320912	ADJUSTABLE STAINLESS STEEL FOR FRANCESCA SEAT
320910	ADJUSTABLE PLASTIC FOR AMELIA & DANIELLE SEATS
320913	TOP FIX FOR ARIANNE, EVE, FRANCESCA, NADIA & TAMARA SEATS
323745	ADJUSTABLE TOP FIX STAINLESS STEEL FOR STANDARD AND SOFT-CLOSE RHIANNA AND ESME SEATS
PLEASE ENQUIRE	ADJUSTABLE BOTTOM FIX STAINLESS STEEL FOR STANDARD AND SOFT-CLOSE RHIANNA AND ESME SEATS

SPARES

DUDLEY ACCLAIM & DIPLOMAT CISTERN

CODE	OPTION
	S7 6/7/9 LITRE CONVERTIBLE SYPHON
	CP FRONT LEVER ASSEMBLY (STATE CISTERN)
316549 319042	ACCLAIM DIPLOMAT
	RED PLASTIC LIFT-ARM (STATE CISTERN)
318166	
	GREEN PLASTIC LIFT-ARM (STATE CISTERN)
313942	
	H/L PLASTIC SIDE LEVER (NEEDS FULCRUM BRACKET AND SCREW - SEE BELOW)
318806 315643 313301	NEW OLD METAL
	FULCRUM BRACKET AND SCREW
313126	

DUDLEY ELITE CISTERN

CODE	OPTION
	S7 216MM (8½") 6/7/9 LITRE CONVERTIBLE SYPHON (LEVER ACTION)
	S88 216MM (8½") 7/9 LITRE CONVERTIBLE SYPHON AND LINKAGE ASSEMBLY (PUSH ACTION)
314642	
	CP PUSH KNOB
313604	
	P2/P3 LEVER LINKAGE: 170MM 125MM ELITE
318741 318851	
	PK PIN, WASHER AND COTTER PIN
318671	
	CP FRONT LEVER ASSEMBLY, 85MM SPINDLE WHITE FRONT LEVER
316549 313907	
	RED PLASTIC LIFT-ARM, 64MM (2½") C/S
318166	
	GREEN PLASTIC LIFT-ARM, 64MM (2½") C/S
313942	
	LID SCREW FOR FRONT LEVER ELITE (1 NEEDED)
316218	

DUDLEY SLIMLINE PLASTIC CISTERN

CODE	OPTION
	S7 216MM (8½") 6/7/9 LITRE CONVERTIBLE SYPHON
	CP FRONT LEVER ASSEMBLY, 85MM SPINDLE
316549	
	RED PLASTIC LIFT-ARM, 64MM (2½") C/S
318166	
	GREEN PLASTIC LIFT-ARM, 64MM (2½") C/S
313942	
	LID SCREW (1 NEEDED)
316218	

DUDLEY TRI-SHELL CISTERN







CODE	OPTION
	S7 191MM (7½") 6/7/9 LITRE CONVERTIBLE SYPHON
	CP METAL FRONT LEVER ASSEMBLY, 95MM SPINDLE
317814	
	RED PLASTIC LIFT-ARM, 64MM (2½") C/S
318166	
	GREEN PLASTIC LIFT-ARM, 64MM (2½") C/S
313942	
	H/L METAL SIDE LEVER (NEEDS FULCRUM BRACKET AND SCREW - SEE BELOW)
314614	
	PLASTIC VERSION
318504	
	FULCRUM BRACKET AND SCREW
313126	
	LID SCREW (2 NEEDED)
313377	

SPARES

DUDLEY TRI-WELL CISTERN

CODE	OPTION
	SYPHON – SEE S1-11 PAGE 13
 315716	SPARES PACK (INCLUDING DIAPHRAGM, 'O' RING AND PISTON WASHER)
 314837	PLASTIC BACKNUT (1½")
 316571	PLASTIC CAPNUT (1½")
 320963	LEVER (S) (10.8MM)
 313126	FULCRUM BRACKET AND SCREW
 313377	LID SCREW (2 NEEDED)

DUDLEY RUBBERLINE/RUBBERWELL CISTERN

CODE	OPTION
 317449 318743	S1-11 229MM (9") 7/9 LITRE CONVERTIBLE SYPHON: WITH BRASS OUTLET AND NUTS (RUBBERLINE) WITH PLASTIC OUTLET AND NUTS (RUBBER WELL)
 315716	SPARES PACK (INCLUDING DIAPHRAGM, WASHERS) 'O' RING AND PISTON
 317234	BRASS BACKNUT
 316382	BRASS CAPNUT
 316171	FULCRUM BRACKET AND SCREW
	LID SCREW (1 NEEDED)

DUDLEY MIRAGE & PHANTOM CONCEALED CISTERN

CODE	OPTION
 316267	S7 216MM (8½") 6/7/9 LITRE CONVERTIBLE SYPHON (LEVER ACTION) SEE PAGE 13
 318166	RED PLASTIC LIFT-ARM (STATE CISTERN)
 313942	GREEN PLASTIC LIFT-ARM (STATE CISTERN)
 314614	H/L METAL SIDE LEVER (L) FOR H/L MIRAGE (NEEDS FULCRUM BRACKET AND SCREW. SEE BELOW)
 313126	FULCRUM BRACKET AND SCREW
 317093 314063 317093 317093	LID SCREW (1 NEEDED): MIRAGE/T88 SYPHON MIRAGE/S7 SYPHON PHANTOM/T88 SYPHON PHANTOM/S7 SYPHON

DUDLEY LEVER ASSEMBLIES WITH LIFT ARM

CODE	OPTION
 315881	CP PLASTIC, 120MM SPINDLE
 317814 313794	CP METAL: 95MM SPINDLE 120MM SPINDLE
 316786 316827 318659 316437 317072	CP WINDSOR: 80MM SPINDLE 95MM SPINDLE 110MM SPINDLE 120MM SPINDLE 140MM SPINDLE
 318767	CP KIT 'P', 155MM SPINDLE, 80MM BUSH*
 319732	CP KIT 'W', 225MM SPINDLE, 160MM BUSH*
 313964	CP KIT 'A', 325MM SPINDLE, 260MM BUSH
 313149	CP KIT 'B', 430MM SPINDLE, 368MM BUSH
 316181 318090 315616 313160	EXTRA FOR 'FRONT FIT' LEVER, ALLEN SCREW AND KEYS: KIT 'P' KIT 'W' KIT 'A' KIT 'B'

SPARES

Select buttons are available in a display friendly box for merchandising purposes. Product codes for 'boxed' product are detailed below.

DUDLEY VANTAGE CONCEALED CISTERN

CODE	OPTION
	313085 CP ROUND OR SQUARE BUTTON 73.5MM DIA: SINGLE FLUSH. ROUND 314600 SINGLE FLUSH. SQUARE 315921 DUALFLUSH. ROUND 318431 DUALFLUSH. SQUARE 327736 SINGLE FLUSH. ROUND. BOXED 327732 DUALFLUSH. SQUARE. BOXED
	316608 GOLD ROUND OR SQUARE PNEUMATIC BUTTON 73.5MM DIA: 317981 SINGLE FLUSH. ROUND 318547 SINGLE FLUSH. SQUARE DUALFLUSH. ROUND DUALFLUSH. SQUARE
	322408 CP DIO PNEUMATIC BUTTON (DUALFLUSH). 51MM DIA. 327733 CP DIO PNEUMATIC BUTTON (DUALFLUSH). BOXED 51MM DIA. 326366 100MM SURROUND ONLY
	313621 CP ROYAL PNEUMATIC BUTTON (SINGLE FLUSH) 51MM DIA. 327735 CP ROYAL PNEUMATIC BUTTON (SINGLE FLUSH) BOXED. 51MM DIA. 324379 CP ROYAL PALM PUSH 51MM 326377 50MM SURROUND ONLY
	323579 ACCESS COVER. FRONT
	313748 ACCESS COVER. TOP
	317532 PUSH-FIT INLET ELBOW
	314962 CONE RING (50MM I.D.)
	319678 CAPNUT (2" BSP/51MM I.D.)
	315604 BACKNUT (2" BSP/51MM I.D.)
	318289 OUTLET SEAL 38MM I.D. 81MM X 59MM X 4MM 323306 OUTLET SEAL 38MM I.D. (STEPPED) 65MM X 37MM X 4MM
	317704 BRAIDED HOSE V1 AND ISOLATING VALVE 325087 BRAIDED HOSE V2 AND ISOLATING VALVE
	327628 NIAGARA PNEUMATIC DUALFLUSH VALVE 6/4, 5/3, 4/2.6L CONVERTS TO SINGLE FLUSH 6 OR 4L. BOXED SEE PAGE 11
	SNAP-FIT CISTERN FIXING BRACKETS 313096 V1 325570 V2
	322326 390 X 290MM FLUSHBEND (TAPERED 2"-1 1/2")
	325972 OUTLET VALVE CAGE

DUDLEY MINIFLO CONCEALED CISTERN

CODE	OPTION
	322905 CP PNEUMATIC BUTTON (DUALFLUSH) 51MM DIA.
	322906 CP/MATT PNEUMATIC BUTTON (DUALFLUSH) 51MM DIA.
	313621 CP ROYAL PNEUMATIC BUTTON (SINGLE FLUSH) 51MM DIA. 327735 CP ROYAL PNEUMATIC BUTTON (SINGLE FLUSH) BOXED. 51MM DIA. 323459 CP ROYAL BUTTON 160MM DIA.
	327628 NIAGARA PNEUMATIC DUALFLUSH VALVE 6/4, 5/3, 4/2.6L CONVERTS TO SINGLE FLUSH 6 OR 4L. BOXED SEE PAGE 11
	323923 ONE PIECE CISTERN HANGING BRACKET
	324371 FLUSHING VOLUME BAFFLES (2 SUPPLIED) 326243 FLUSHING BAFFLES (FOR VANTAGE CISTERN)
	322326 FLUSHBEND 390 X 290MM (TAPERED 2"-1 1/2")

DUDLEY UNIVERSAL CISTERN SERVICING KIT

CODE	OPTION
327518	INCLUDES A DUDLEY TURBO 88 ADJUSTABLE SYPHON, DUDLEY HYDROFLO TELESCOPIC INLET VALVE, CLOSE-COUPPING FIXING BOLTS, SEALING WASHER AND 100MM MAZAK FRONT LEVER
325829	INCLUDES A DUDLEY TURBO 88 ADJUSTABLE SYPHON, DUDLEY HYDROFLO TELESCOPIC BRASS TAIL INLET VALVE, CLOSE-COUPPING FIXING BOLTS, SEALING WASHER AND 100MM MAZAK FRONT LEVER
325830	INCLUDES A DUDLEY NIAGARA DUALFLUSH VALVE AND DUALFLUSH PNEUMATIC 73.5MM BUTTON, AIR TUBES, CAPNUT AND CONE RING
326426	INCLUDES A DUDLEY NIAGARA SINGLE FLUSH VALVE AND SINGLE FLUSH PNEUMATIC 73.5MM BUTTON
327402	INCLUDES A DUDLEY VICTORIA FLUSH VALVE AND HYDROFLO TELESCOPIC INLET VALVE

DUDLEY ELECTROFLO WC FLUSHING





CODE	OPTION
323107	MAINS ADAPTOR

SPARES

DUDLEY PUSHFLO & ROYAL PUSHFLO CONCEALED CISTERNS

CODE	OPTION
 316562	CP DOME BUTTON FOR PUSHFLO CISTERN (SINGLE FLUSH) 91MM DIA.
 316269	CP CONE BUTTON FOR PUSHFLO CISTERN (SINGLE FLUSH) 50MM DIA.
 320185	CP PETITE BUTTON FOR PUSHFLO CISTERN (SINGLE FLUSH) 46MM DIA.
 313621 327735	CP ROYAL PNEUMATIC BUTTON FOR ROYAL PUSHFLO CISTERN (SINGLE FLUSH) 51MM DIA. CP ROYAL PNEUMATIC BUTTON (SINGLE FLUSH) BOXED. 51MM DIA.
324379	CP ROYAL PALM PUSH 57MM BOXED
 314962	CONE RING (50MM I.D.)
316721	SLIP RING
 319678	CAPNUT (2" BSP/51MM I.D.)
 315604	BACKNUT (2" BSP/51MM I.D.)
318948	OUTLET WASHER BLACK (2" BSP/51MM I.D.)
 315297	SEALING WASHER GREY (2" BSP/51MM I.D.) 60MM X 24MM X 3MM
 327628	NIAGARA PNEUMATIC 6 OR 4L SINGLE FLUSH VALVE (ALSO CONVERTS TO 6/4, 5/3, OR 4/2.6L DUALFLUSH). BOXED SEE PAGE 11
 316129	PINTO PNEUMATIC 6L SINGLE FLUSH VALVE FOR PUSHFLO CISTERN

CP DIMPLE LEVER ASSEMBLIES FOR EASY FLUSHING BY THE LESS ABLE

CODE	OPTION
 315568	120MM SPINDLE WITH 'CAMEL' ADJUSTABLE LIFT-ARM
 317591	KIT 'W' VERSION WITH 225MM SPINDLE, 160MM BUSH
 318252	KIT 'A' VERSION WITH 325MM SPINDLE, 260MM BUSH
 318138	KIT 'B' VERSION WITH 430MM SPINDLE, 368MM BUSH

BUTTON & FLUSH VALVE SPARES

CODE	OPTION
 319473	VR (VANDAL-RESISTANT) FLAT METAL BUTTON FOR PUSHFLO CISTERN - FITS UP TO 38MM PARTITION (SINGLE FLUSH) 63.5MM DIA.
 315521	METAL DOME BUTTON FOR PUSHFLO CISTERN (SINGLE FLUSH) 91MM DIA.
 321685	METAL ROYAL BUTTON FOR ROYAL PUSHFLO AND VANTAGE CISTERN (SINGLE FLUSH) 51MM DIA.
 319059 318634	PNEUMATIC TUBE: CLEAR 750MM GREEN 750MM
 313838	CORRUGATED TUBE
 321958	PAN CONNECTOR (CLEAR)
319896	DUALFLUSH BUTTON FOR CABLE OPERATED VALVE

SPARES











BALL VALVES & GENERAL PARTS

CODE	OPTION
 317152 316574	32MM (1¼") DIA. SHAPED RUBBER DIAPHRAGM TORBECK BETA
 PLEASE ENQUIRE	TORBECK EQUILIBRIUM ENQUIRE QUIET-FILLING BALLVALVE SISO OR BIBO (ALT. SEE DUDLEY HYDROFLO PAGE 22)
 318410	13MM (½") PLASTIC PETCOCK FOR AUTOMATICS
 317820	114MM (4½") ROUND "QUALIFLOAT" PLASTIC FLOAT
 317501	114MM (4½") ELONGATED PLASTIC FLOAT
 316828	19MM (¾") PLASTIC OVERFLOW
 316308	19MM (¾") PLASTIC PEDESTAL OVERFLOW 215MM
 314065	PLATED CHAIN AND PLASTIC PULL
 315841 315432	TAPERED CONE RING FOR FLUSHBEND 38MM LOW LEVEL 32MM HIGH LEVEL
 317165 316340	'CAMEL' ADJUSTABLE LIFT-ARM: NATURAL BLUE
 319249	OVERFLOW STOPPER 19MM
315267	CLEAR BUNG

PVC FLUSHBENDS & FLUSHPIPES

CODE	OPTION
319415	356 X 229 X 38MM (14" X 9" X 1½") O.D. - WHITE
PLEASE ENQUIRE	356 X 229 X 38MM (14" X 9" X 1½") O.D. - COLOUR
322326	390 X 290MM TAPERED 51-41MM - WHITE
323782	559 X 450MM TAPERED 51-41MM - WHITE (EUROPIPE)
317684	610 X 457 X 38MM (24" X 18" X 1½") O.D. - WHITE

HYDROFLO INLET FLOAT VALVE

CODE	OPTION
 317158	FILTER AND 'O' RING
 313299	FILTER KEY
 317673	RUBBER WASHER (37.5MM O.D.)
 317733	FLOAT
 318949	STANDARD FLOAT ARM AND PRESSURE CHAMBER COVER (AS SHOWN)
 327211	DELAY FILL FLOAT ARM AND PRESSURE CHAMBER COVER (NOT SHOWN)
 319626	SILENCE TUBE
 318756 315067 325899 324037	FLOW RESTRICTOR BLUE - VANTAGE GREEN - TELESCOPIC RED - MINIFLO
 319726	DIAPHRAGM
 331186	DELAY FILL DIAPHRAGM
 316295	BACKNUT (½" BSP)
 316999	OVERHEAD DISCHARGE NOZZLE ASSEMBLY (DIVERTOR INCLUDING SILENCE TUBE)

PVC FLUSHBENDS & FLUSHPIPES

CODE	OPTION
316561 314661	1678 X 32MM (5' 6" X 1¼") BORE 2-PIECE BACKWALL: 38MM (1½") COLLAR - WHITE 44MM (1¾") COLLAR - WHITE
314758 315587	1678 X 32MM (5' 6" X 1¼") BORE 3-PIECE SIDEWALL: 38MM (1½") COLLAR - WHITE 44MM (1¾") COLLAR - WHITE
318054	FLOW RESTRICTOR FOR HIGH LEVEL FLUSHPIPE (BAFFLE)
317308	FINNED PUSH-IN WC PAN CONNECTOR

SPARES

SYPHON ACCESSORIES

CODE	OPTION
 313313	DUDLEY 'SYVAC' SYPHONIC ASPIRATOR (FOR S7 AND T88 ONLY)
PLEASE ENQUIRE	PLASTIC PISTON COMPLETE WITH POLYTHENE DIAPHRAGM
316855 319797	TURBO 88 TURBO S1-11
 314837	PLASTIC BACKNUT 38MM
 316571	PLASTIC CAPNUT 38MM
 318134	SS 'C' LINK UP TO 76MM (3")
318762 317307 317898	SS 'C' LINK: 3 1/4" 3 1/2" 3 5/8"
317143 322946 318323 317537	SS 'C' LINK: 4" 4 1/4" 4 1/2" 5 1/2"
PLEASE ENQUIRE 313245 314095 316288 316576	POLYTHENE SYPHON DIAPHRAGM TURBO 88/CASCADE S9 HI-FLO/JAPTIC TURBO S44 TURBO S1-11
PLEASE ENQUIRE	PLASTIC AUTOMATIC SYPHON FOR 22MM PIPE
319228 315716	TURBO 88 SPARES PACK (INC. DIAPHRAGM, 'O' RING AND PISTON WASHERS) TURBO S1-11 SPARES PACK
318665	TURBO 44 SPARES PACK (INC. DIAPHRAGM, 'O' RING AND PISTON WASHERS)
315267 320494 326064	CLEAR BUNG WHITE CAPS DUALFLUSH WASHER

SYPHON ACCESSORIES

CODE	OPTION
	NIAGARA MECHANICAL
 318082	38MM (1 1/2") OUTLET ADAPTOR (ALSO FITS PINTO VALVE)
 314318	CP PUSHBUTTON ASSEMBLY PACK
 315900	PUSH RODS
 314574	OUTLET SEAL 38MM (I.D.)
	NIAGARA PNEUMATIC
323768 318947	BELLOWS BELLOWS FOR PINTO VALVE
	MECHANICAL AND PNEUMATIC
 318289	OUTLET WASHER (2" BSP/51MM I.D.)
 315604	BACKNUT (2" BSP/51MM I.D.)
 319678	CAPNUT (2" BSP/51MM I.D.)

TERMS & CONDITIONS

1 DEFINITIONS

- 11 The Company means Thomas Dudley Limited
- 12 The Buyer means the person, firm or company who purchases the Goods from the Company.
- 13 Contract means any contract between the Company and the Buyer for the sale of goods or services from the Company to the Buyer;
- 14 Delivery Point: the place where delivery of the Goods is to take place under conditions 6.1 or 6.7;
- 15 Goods: any goods or services agreed in the Contract to be supplied to the Buyer by the Company on any goods supplied in substitution of the original Goods, (including any parts or part of them) pursuant to Clause 10 and Clause 13.2 and Clause 14.1 of this Contract;
- 16 A reference to a particular law is a reference to it as it is in force for the time being taking account of any amendment, extension, application or re-enactment and includes any subordinate legislation for the time being in force made under it;
- 17 A reference to one gender includes a reference to the other gender;
- 18 Condition headings do not affect the interpretation of these conditions.

2 APPLICATION

- 21 These Conditions apply to all Contracts for the sale of goods and/or supply of services by the Company to any Buyer and prevail over and extinguish all terms and conditions of contract imposed by the Buyer or implied by trade, custom, practice or course of dealing in so far as such terms and conditions are inconsistent therewith or additional thereto.
- 22 No alteration, exclusion or waiver of any of these conditions shall be effective or binding unless made in writing by a Director of the Company. The Buyer acknowledges that it has not relied on any statement, promise or representation made or given by or on behalf of the Company which is not set out in this Contract and neither party has a remedy against the other party for any representations, statements or promises not set out in the Contract. Nothing in this condition shall exclude or limit the Company's liability for fraudulent misrepresentation.

3 QUOTATION, ORDER AND ACCEPTANCE

- 31 Any quotation by the Company does not constitute an offer and is given on the basis that no Contract shall come into existence until the Company despatches an acceptance of the order to the Buyer. Any quotation given by the Company is valid for a period of 30 days only from its date, provided that the Company has not previously withdrawn it, and may be revised or withdrawn at any time prior to the Buyer's acceptance of the Buyer's order.
- 32 Each order or acceptance of a quotation for Goods by the Buyer shall be deemed to be an offer by the Buyer to buy the Goods subject to these conditions.
- 33 The Buyer's order, whether verbal or written, shall not be deemed to have been accepted until the Company has issued its written acknowledgement form and the Buyer's credit has been approved by the Company or satisfactory security for payment has been given.
- 34 The Buyer shall ensure that the terms of its order and any applicable specification are complete and accurate. No order which has been accepted by the Company may be cancelled or varied by the Buyer except with the written agreement of the Company and on such terms that the Buyer shall indemnify the Company in full against all loss (including loss of profits), costs (including costs of labour, materials, expenses or used, tooling and all manufacturing costs), damages, charges and any other costs incurred by the Company as a result of such cancellation or variation.
- 35 The Company shall be entitled to suspend or end the provision of all or any part of the Goods or services to be provided to the Buyer under this Contract at any time where there is a monetary amount outstanding from the Buyer to the Company under any other Contract made between the Buyer and the Company for the provision by the Company of Goods or services.

4 DESCRIPTION

- 41 The quantity and description of the Goods shall be as set out in the Company's acknowledgement of order.
- 42 All samples, drawings, descriptive matter, specifications and advertising issued by the Company and any descriptions or illustrations contained in the Company's catalogues or brochures are issued or published for the sole purpose of giving an approximate idea of the Goods described in them. They shall not form part of the Contract and this is not a sale by sample.

5 PRICES

- 51 The price payable by the Buyer for each Delivery of the Goods shall be the Company's price ruling at date of despatch. The Company may at any time revise prices to take into account any increase in the Company's costs (including, but not limited to the cost of raw materials, labour, energy, transport or other overheads, any tax due or other levy and variation in exchange rates).
- 52 Unless otherwise specified, VAT and any other tax or duties payable by the Company shall be added to the price payable by the Buyer.

6 DELIVERY AND COLLECTION

- 61 Delivery shall take place on a safe hard road, as near as legally permitted to the Buyer's specified Delivery point as provided on the Buyer's order form. The Buyer will be responsible for the costs and provision of safe offloading facilities and manual labour ensuring that Delivery is completed without undue delay or the Buyer will be liable to indemnify the Company for the Company's costs incurred as a result of such delay.
- 62 Unless otherwise stated, all quotations assume Delivery in full loads by any method of transport at the Company's option.
- 63 Any time or date for Delivery is given and intended as an estimate only and time for delivery shall not be made of the essence by notice. If no date for Delivery is specified, Delivery shall be within a reasonable time. The Company shall not be liable for any direct or indirect loss or damage (including, without limitation, pure economic loss, loss of profits, loss of business, depletion of goodwill and similar losses) costs, damages charges or expenses caused directly or indirectly by any delay in the Delivery of the Goods (even if caused by the Company's negligence), nor shall any delay entitle the Buyer to terminate or rescind the Contract unless such delay exceeds 60 days from the original estimated Delivery date.
- 64 Signature on the Company's delivery note by an employee, representative or agent of the Buyer shall be conclusive proof of the quantity received by the Buyer and of Delivery to the Buyer.
- 65 If the Company delivers to the Buyer a quantity of goods of up to 5% more or less than the order accepted by the Company, the Buyer shall not be entitled to object or reject the Goods or any of them by reason of the surplus or shortfall and the Buyer shall pay for such goods at the pro rata Contract rate.
- 66 The Company may make deliveries partially or by instalment. Each separate instalment shall be invoiced and paid for in accordance with the provisions of this Contract. Each instalment shall be a separate Contract and no cancellation or termination of any one Contract relating to an instalment shall entitle the Buyer to repudiate or cancel any other Contract or instalment.
- 67 When the Buyer arranges transport of the Goods from the Company's place of business, Delivery shall take place at the Company's place of business and the Buyer shall take Delivery of the Goods within 3 days of being given notice by the Company that the Goods are ready for delivery.
- 68 If for any reason the Buyer fails to accept Delivery in accordance with Clause 6.1 or 6.7, or the Company is unable to deliver the Goods on time because the Buyer has not provided adequate or appropriate instructions, documents licenses or authorisations:

- 68.1 The Goods shall be deemed to have been delivered at the Buyer's premises if the Delivery is arranged pursuant to Clause 6.1. If delivery is arranged pursuant to Clause 6.7, Delivery will be deemed to have taken place at the expiry of 3 working days of the Company giving notice that the goods are ready for delivery.
- 68.2 Risk in the Goods shall pass to the Buyer (including for loss or damage caused by the Company's negligence).
- 68.3 If the Buyer fails to take, or refuses to accept Delivery of any of the Goods the Buyer may charge for the refused delivery and any associated costs and may store the Goods until collection by the Buyer from the Company's premises and charge the Buyer reasonable costs of storage, insurance and re-delivery or without affecting the continuation of the Contract, sell the Goods.
- 69 The Company shall not be liable for any damage, discrepancy non-Delivery or short Delivery of the Goods (even if caused by the Company's negligence) unless the Buyer gives written notice to the Company of the non-delivery within 3 days of the date when the Goods would in the ordinary course of events have been received.
- 610 Any liability of the Company for non-Delivery of the Goods shall be limited to replacing the Goods within a reasonable time or issuing a credit note at the pro rata Contract rate against any invoice raised for such Goods.

7 RETURNABLE PACKAGING

- 71 Pallets, stailages and special containers are returnable to the Company, and remain the property of the Company, they or equivalent like items shall be returned in good condition to the Company following delivery.

8 TECHNICAL DATA

- 81 All Company drawings, descriptive matter, price lists, brochures or advertisements whether or not supplied with a quotation or tender are approximate only and

intended merely to give a general idea of the goods described therein and shall not form part of the Contract. Any tools, patterns and samples, unless paid for in full, and drawings, specifications or other information provided remains the Company's property and all technical information, patentable or unpatentable copyright and registered designs arising from the execution of any orders are the property of the Company. They must not be copied, disclosed or given to any third party without the written permission of the Company. Any research studies, quality enhancement or cost reduction measures shall remain the property of the Company and such information shall be kept confidential by the Buyer.

9 INDEMNITY

The Buyer shall indemnify the Company against all damages, costs, penalties and expenses arising out of or lost suffered as a result of any work carried out in connection with the Goods (including the Goods) as agreed in writing or any negligent infringement of a patent, design whether registered or unregistered, trade mark, copyright or any other industrial property right. If the Buyer uses, sells, causes to be sited or installed the Goods in such a manner as to infringe such rights the Company shall not be responsible for such infringement and the Buyer agrees to indemnify the Company from and against all liability arising there from.

10 IDENTIFICATION AND SPECIFICATION

The Company reserves the right to substitute goods of equivalent strength and quality without prior reference to the Buyer.

11 TERMS OF PAYMENT

- 111 Payment shall be received in full by the Company by the end of the month following the date of the Company's invoice.
- 112 Time of payment is of the essence.
- 113 In the event of late or non-payment the Company shall be entitled to charge interest on such sum from the due date for payment at the annual rate of 4% above the Bank of England's base rate as published in the London Gazette accruing on a daily basis until payment is made, whether before or after any judgment. The Company reserves the right to claim interest under the Late Payment of Commercial Debts (Interest) Act 1998. In such circumstance any settlement discount will cease to apply and the full price shall be due and payable immediately by the Buyer to the Company.
- 114 The Company shall be entitled, at its discretion, to withdraw credit facilities and suspend any time in which events or sums outstanding from the Buyer to the Company shall become due and payable immediately.
- 115 In the event of termination of the Contract for any reason whatsoever, all sums outstanding from the Buyer to the Company shall become due and payable immediately.
- 116 The Buyer shall not be entitled to withhold or delay payment or exercise any right to set off howsoever arising or arisen which might otherwise be available to it.

12 TITLE AND RISK

- 121 Goods supplied shall remain the property of Thomas Dudley Limited until all money due has been paid in cleared funds. Risk passes to the Buyer on Delivery.
- 122 Until payment of all money due to Thomas Dudley Limited the Buyer undertakes to:
 - 122.1 Hold the Goods on a fiduciary basis as the Company's bailee; and
 - 122.2 Keep the Goods stored separately [at no cost to the Company] and in such a manner as to make the Goods clearly identifiable separate from all other and easily and clearly identifiable upon examination; and
 - 122.3 Not destroy, deface or obscure any identifying mark or packaging on or relating to the Goods; and
 - 122.4 Maintain the Goods in satisfactory condition and keep them insured on the Company's behalf for their full price against all risks to the reasonable satisfaction of the Company. On request the Buyer shall produce the policy of insurance to the Company.
- 123 The Buyer shall deliver the Goods before ownership has passed to it solely on the following conditions:
 - 123.1 Any sale shall be effected in the ordinary course of the Buyer's business at full market value; and
 - 123.2 Any such sale shall be a sale of the Company's property on the Buyer's own behalf and the Buyer shall deal as principal when making such a sale; and
 - 123.3 Any of the proceeds from the sale of the Company's Goods shall be retained and separate from the Goods.
- 124 The Buyer's right to possession of the Goods shall terminate immediately if:
 - 124.1 The Buyer has a bankruptcy order made against him/ it or makes an arrangement or composition with his creditors, or otherwise takes the benefit of any statutory provision for the time being in force for the relief of insolvent debtors; or (being a body corporate) convenes a meeting of creditors (whether formal or informal), or enters into liquidation (whether voluntary or compulsory) except a solvent voluntary liquidation for the purpose only of reconstruction or amalgamation; or has a receiver and/or manager, administrator or administrative receiver appointed of its undertaking or any part thereof; or documents are filed with the court for the appointment of an administrator of the Buyer or notice of intention to appoint an administrator is given by the Buyer or its Directors or by a qualifying floating charge holder (as defined in paragraph 14 of Schedule B1 to the Insolvency Act 1986), or a resolution is passed or a petition presented to any court for the winding up of the Buyer or for the granting of an administration order in respect of the Buyer, or any proceedings are commenced relating to the insolvency or possible insolvency of the Buyer; or
 - 124.2 The Buyer suffers or allows an execution, whether legal or equitable, to be levied on his/its property or obtained against him/ it, or fails to observe or perform any of his/its obligations under the Contract or any other Contract between the Company and the Buyer, or is unable to pay its debts within the meaning of section 127 of the Insolvency Act 1986 or the Buyer ceases to trade; or
 - 124.3 The Buyer encumbers or purports to in any way charges any of the Goods.
- 125 The Company shall be entitled to recover payment for the Goods notwithstanding that ownership of any of the Goods has not passed from the Company.
- 126 The Buyer grants the Company, its agents and employees an irrevocable licence at any time to enter any premises where the Goods are or may be stored, to inspect, respect them, or where the Buyer's right to possession has terminated, to recover them.
- 127 Where the Company is unable to determine whether any Goods are the Goods in respect of which the Buyer's right to possession has terminated, the Buyer shall be deemed to have sold all Goods of the kind sold by the Company to the Buyer in the order in which they were invoiced to the Buyer;
- 128 On termination of the Contract, howsoever caused the Company's (but not the Buyer's) rights contained in this condition shall remain in effect.

13 QUALITY

- 131 The Company warrants all Goods which have been supplied by the Company against any defect of materials or workmanship arising within a period of 12 months of Delivery which can be proved to the Company's satisfaction to have been caused before Delivery. The above warranty is given subject to the following conditions:
 - 131.1 Full details of any such defect are notified to the Company in writing within 14 days of its first discovery;
 - 131.2 The Goods have been properly used for their normal purpose, handled, maintained, stored and installed in accordance with the Company's installation instructions and good practice;
 - 131.3 The Company shall be under no liability in respect of any defect arising from any fair wear or tear, willful damage, negligence, abnormal working conditions, failure to follow the Company's instructions, whether oral or in writing, misuse or repair of the Goods without the Company's approval; and
 - 131.4 The Goods in which the defect arises are returned undamaged and adequately packed at the Buyer's expense to the Company.
- 132 The liability of the Company shall be limited at its option either to supplying replacement Goods, which will be supplied subject to these terms, or refunding the price of the Goods.
- 133 The Company shall be under no liability under the said warranty if:
 - 133.1 The Buyer has not paid in full for the Goods; or
 - 133.2 The Buyer or his customer has executed or attempted to execute repairs or alterations to the Goods which are not authorised in writing by the Company or has failed in any other respect to adhere strictly to the terms hereof; or
 - 133.3 The Company has not been notified of any defect within 14 days of the discovery of the defect, or
 - 133.4 The Goods are returned to the Company inadequately packaged, in which event any damage to the Goods will be deemed to have resulted from the Buyer's inadequate packaging and not from any defect in materials or workmanship; or
 - 133.5 If the Buyer has used the Goods without first having carried out all the inspections and tests which the design and use necessitate; or
 - 133.6 when any fault is attributable to the whole unit in which the Goods are incorporated or to any modification carried out after Delivery.
- 134 Except for the express warranties set out above, the Company grants no other warranties relating to defects in design, workmanship, or materials of the

Goods and all other conditions, warranties, stipulations, or other statements whatsoever whether express or implied, by statute at common law or otherwise howsoever, relating to such defects in the Goods and services are hereby excluded.

- 135 Where the Buyer notified the Company as aforesaid and the Company performs its obligations under these conditions the Buyer shall not be entitled to claim any interest on the Goods or for work done thereon or any other costs or losses, direct or indirect or consequential and loss of profits whatsoever (save where death or personal injury has been caused by the Company's negligence) nor shall the Buyer be entitled to repudiate the Contract, fail to pay for the Goods or cancel deliveries. The Buyer shall indemnify the Company against all costs of dismantling, digging out, replacement and reassembly.
- 136 Nothing in these conditions excludes or limits the liability of the Company:
 - 136.1 for death or personal injury caused by the Company's negligence; or
 - 136.2 for any matter which it would be illegal for the Company to exclude or attempt to exclude its liability or
 - 136.3 for fraud or fraudulent misrepresentation;
- 137 Subject to the above condition;
- 137.1 The Company's total liability in contract, tort (including negligence or breach of statutory duty) misrepresentation, restitution or otherwise arising in connection with the performance or contemplated performance of the Contract shall be limited to the Contract price;
- 137.2 The Company shall not be liable to the Buyer for any pure economic loss, loss of profit, loss of business, depletion of goodwill or otherwise, in each case whether direct, indirect or consequential, or any claims for consequential compensation whatsoever (howsoever caused) which arise out of or in connection with the Contract.

14 LIABILITY

- 141 The above warranty is limited to the supply to the Buyer free at his premises of the new Goods or parts in exchange for any acknowledged by the Company to be defective. The decision of the Company on all claims and all questions as to defects and as to the exchange of the Goods shall be final and conclusive.
- 142 The warranty above shall also apply to any replaced goods provided hereunder during the unexpired period applicable to the Goods for which the replacement has been performed.
- 143 Other than stated above, the Company undertakes no liability whatsoever in respect of the Goods sold by it and shall in no circumstances be liable in respect of loss, damage or delay, injury or expense, direct or consequential suffered at any time whether before or after the Goods may have been repaired or replaced, and howsoever caused, even if caused by negligence or breach of duty by the Company, its servants or agents. The terms set out herein are conclusive of the relationship between the Company and the Buyer and the Company shall be under no liability whatsoever by reason of any representation, statement or warranty made or given by the Buyer or the Company in any term, condition or warranty statutory or otherwise. Nothing in these conditions shall affect the statutory liability of the Company for death or personal injury caused by negligence.
- 144 The Company undertakes no liability whatsoever in respect of operations subsequently carried out on products before their use, nor for cost of assembly, disassembly and withdrawal from service.

15 PATTERNS, TOOLS

- 151 Any patterns, core boxes, tools or dies (the Equipment) manufactured by or on behalf of the Company remain the property of the Company even though the Buyer may have been charged for part of the cost. Except for loss or damage caused directly by the Company's negligence (for which the Company's liability shall be limited to the direct cost of replacements or repair) the Company accepts no liability for loss or damage to the Equipment which is in the Company's possession or control or in its quarters.
- 152 Where the Equipment has not been used for a period of two years the Company may, after giving the Buyer one month's notice in writing, dispose of it. In the event that the Equipment needs repair or replacement it will be undertaken by the Company only upon the basis that the Buyer contributes to the cost.
- 153 Where Equipment is provided by the Buyer he is responsible for ensuring that it matches the drawings and required specifications. If the Company carries out additional work requested by the Buyer it reserves the right to charge the cost to the Buyer. In all cases if the Equipment received by the Company does not conform to the specifications the initially agreed price of the Goods may be revised.
- 154 All money due must be paid to the Company before Equipment is released to the Buyer or a third party.
- 155 Once manufacture of Equipment has commenced, cancellation cannot be demanded and any costs incurred in the manufacture of Equipment must be paid by the Buyer in full. Equipment must be paid for in the month of delivery of samples even though subsequent modification may be required or the project is abandoned.

16 ASSIGNMENT

- 161 The Buyer shall not assign the Contract of which these Conditions form part or any part of it without the prior written consent of the Company. The Company reserves the right to subcontract the performance of the Contract or any part of it.

17 FORCE MAJEURE

- 171 The Company shall not be liable to the Buyer or be deemed to be in breach of the Contract by reason of any delay in delivery or any delay in performing or any failure to perform any of the Company's obligations if the delay or failure arises directly or indirectly from any cause beyond the Company's reasonable control. Without prejudice to the generality of the foregoing, the following shall be regarded as causes beyond the Company's reasonable control: Act of God, burglary, explosion, flood, storm, fire or accident, war or threat of war, terrorism, sabotage, insurrection, civil disturbance or requisition; acts, restrictions, regulations by laws, prohibitions or measures of any kind on the part of any governmental, parliamentary or local authority; import or export regulations or embargoes; strikes, lockouts or other industrial actions or trade disputes (whether involving employees of the Company or a third party); difficulty or increased expense in obtaining materials, labour, transport, fuel, parts or machinery; power failure or breakdown in machinery and equipment.

18 FREE ISSUE COMPONENTS

- 181 It is the Buyer's responsibility to ensure that all components supplied by them for use in the products manufactured are fit for purpose and comply fully with the required specification. The Buyer will supply free issue in sufficient and timely quantities to allow for the Company's production programme. The Company accepts no liability for failure of components supplied by the Buyer.

19 NOTICES

- 191 Any notice or communication given hereunder must be in writing and may be effected by personal delivery, facsimile, e-mail or by registered mail. If effected by personal delivery notices shall be deemed to be received on the date of such delivery, if by facsimile or email on the day of sending and if by post 48 hours after the date of posting.

20 LIEN

- 201 The Company shall in respect of all unpaid debts due from the Buyer have a general lien on all goods and property of the Buyer in its possession (although such goods or some of them may have been paid for) and upon 14 days written notice to the Buyer may dispose of such goods and property and apply the proceeds towards the satisfaction of the sums due to the Company.

21 INDULGENCE OR FORBEARANCE

- 211 The rights of the parties shall not be prejudiced or restricted by any indulgence or forbearance extended to them by the other party and no waiver by either party in respect of any breach shall operate as a waiver in respect of any subsequent breach.

22 DEFAULT OF BUYER (TERMINATION)

- 221 If the Buyer defaults in or commits any breach of any of its obligations to the Company, or ceases to carry out its business or a substantial part thereof, or if any distress or execution is levied on any of the Buyer's property or the Buyer makes or offers to make any arrangement with his creditors or commits any act which is a bankruptcy or insolvency or a winding up or a liquidation or a receivership is passed or presented or a receiver, liquidator or similar official is appointed of the Buyer's undertaking, or any payment of the whole or any part of the purchase price of the Goods is dishonoured by the Buyer's bank, then the Company shall be entitled forthwith to terminate this and any other Contract with the Buyer in writing to the Buyer's last known address.

23 SEVERANCE

- 231 If any condition herein shall be deemed void for any reason whatsoever, but which would be valid if part of the wording were deleted, any such condition shall apply with such modifications as may be necessary to make it valid and effective.

24 ENGLISH LAW

- 241 The Contract and these Conditions shall be governed by English Law and the Buyer shall submit to the sole jurisdiction of the English Courts.

DUDLEY VALUES

OUR MISSION

To be an outstanding family business supplying high quality, Innovative products, backed by exceptional customer service that promotes lifelong customer loyalty.

OUR PURPOSE

To grow our people, profits and turnover in a safe and enjoyable environment for the benefit of our employees, customers and stakeholders.

OUR VALUES

CORE:

SAFETY FIRST

PARTNERSHIP

ETHICAL

CUSTOMER FOCUSED

INVESTING

FAMILY

INNOVATIVE

CONTINUOUS IMPROVEMENT

ASPIRATIONAL:

TEAMWORK

ENJOYABLE

ACHIEVE OUR GOALS

MARKET LEADING



Thomas Dudley

295 Birmingham New Road
Dudley, West Midlands
United Kingdom
DY1 4SJ

Tel: 0121 530 7000

Fax: 0121 557 5345

Email: sales@thomasdudley.co.uk

www.thomasdudley.co.uk



Part of the Thomas Dudley Family