

FLUE KIT INSTALLATION INSTRUCTIONS

7 716 190 064 ROOM SEALED 80/125mm STANDARD TELESCOPIC FLUE

7 716 190 062 ROOM SEALED 80/125mm SHORT TELESCOPIC FLUE

7 716 190 092 80mm PLUME MANAGEMENT SYSTEM

7 716 190 032 ROOM SEALED 80/125mm VERTICAL FLUE

7 716 190 059 ROOM SEALED 100/150mm VERTICAL FLUE

GREENSTAR OILFIT FLUE

FOR USE WITH WORCESTER: Greenstar Utility 18/25, Danesmoor 18/25, Danesmoor Wall Hung 12/18 & 18/25, Heatslave 12/18, 18/25 & 25/32, Camray Kitchen 12/18, 18/25 & 25/32, Camray 12/18, 18/25 & 25/32, Camray 18/25 & 25/32 External and Heatslave 12/18, 18/25 & 25/32 External.
DO NOT USE WITH ANY OTHER MODEL OF APPLIANCE

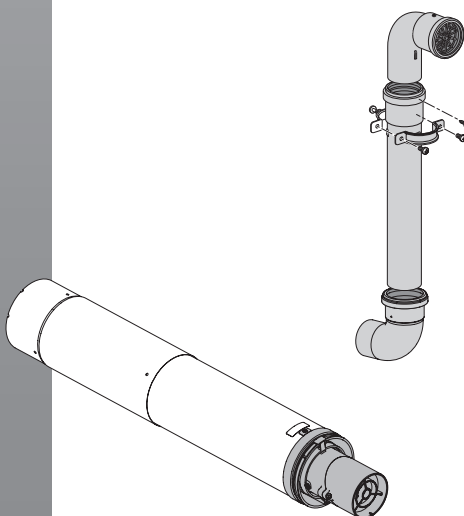
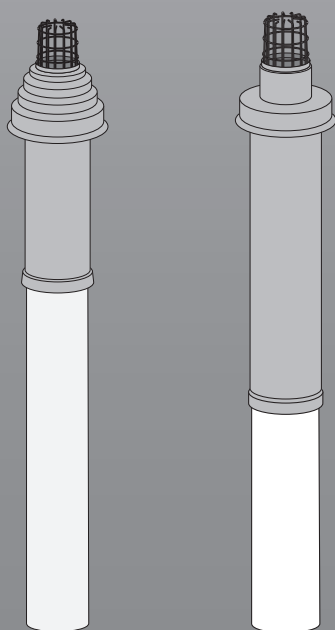

6720645523-00.1Wo

CONTENTS

1	Key to symbols and safety precautions	3	7	Installation	23
1.1	Explanation of symbols	3	7.1	plume management installation - standard	23
1.2	Safety precautions	4	7.2	Plume management installation - external boilers	24
2	Product information	5	7.3	Plume management installation - extended	25
2.1	Room sealed vertical flue components . . .	5	7.4	Redirecting the flue discharge	26
2.2	Room sealed telescopic horizontal flue components	6	7.5	Extended plume management installation for a balcony or overhang	27
2.3	Room sealed flue extension components .	6			
3	Pre-installation	7			
3.1	Flue terminal positions	7			
3.2	Flue systems in voids	8			
4	Installation	9			
4.1	Room sealed flue measurement	9			
4.1.1	Determine the effective flue length (L) . . .	9			
4.1.2	Actual flue length	10			
4.2	Flue adjustment and cutting	11			
4.2.1	Telescopic flue adjustment	11			
4.2.2	Reducing the telescopic flue length	11			
4.2.3	Reducing flue length	11			
4.3	Room sealed flue fitting	12			
4.4	Room sealed flue terminal & extensions .	14			
4.4.1	Vertical terminals	14			
4.4.2	Horizontal terminals	15			
4.4.3	Extensions	15			
4.5	Wall mounted oil boilers	16			
4.5.1	Maximum flue lengths	16			
4.5.2	Vertical flue	16			
4.5.3	Horizontal flue	16			
5	Plume management product Information	17			
5.1	Plume management system components	17			
6	Plume management	18			
6.1	Pre-installation	18			
6.2	Plume management options & measurement	19			
6.3	Determine the plume management system length	20			
6.3.1	Flue dampers	20			
6.3.2	Plume management	20			
6.3.3	Plume management length - floor standing boilers	20			
6.3.4	Plume management length - wall mounted boilers	21			
6.4	Measuring for a plume management system	22			
6.5	Modify Non telescopic flue to accept plume management	22			

1 KEY TO SYMBOLS AND SAFETY PRECAUTIONS

1.1 EXPLANATION OF SYMBOLS

WARNING SYMBOLS

	Safety instructions in this document are framed and identified by a warning triangle which is printed on a grey background.
---	---

	Electrical hazards are identified by a lightning symbol surrounded by a warning triangle.
---	---

Signal words indicate the seriousness of the hazard in terms of the consequences of not following the safety instructions.

- **NOTICE** indicates possible damage to property or equipment, but where there is no risk of injury.
- **CAUTION** indicates possible injury.
- **WARNING** indicates possible severe injury.
- **DANGER** indicates possible risk to life.

IMPORTANT INFORMATION

	Notes contain important information in cases where there is no risk of personal injury or material losses and are identified by the symbol shown on the left. They are bordered by horizontal lines above and below the text.
---	---

ADDITIONAL SYMBOLS

Symbol	Meaning
▶	a step in an action sequence
→	a reference to a related part in the document or to other related documents
•	a list entry
–	a list entry (second level)

Table 1 Documentation symbols

ABBREVIATIONS

∅	Diameter
RS	Room Sealed

Table 2 Abbreviations

SYMBOLS

	Cutting required
	Cutting not required

Table 3 Symbols

1.2 SAFETY PRECAUTIONS

IN THE EVENT OF ANY OIL SMELLS, LEAKS OR FUMES FROM THE APPLIANCE:

- ▶ PUT OUT NAKED FLAMES
- ▶ OPEN DOORS AND WINDOWS
- ▶ ISOLATE THE ELECTRICAL SUPPLY
- ▶ ISOLATE THE FUEL SUPPLY AT THE BOILER
- ▶ RECTIFY THE FAULT

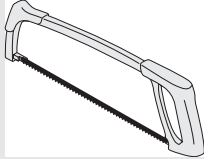
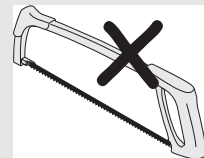
BOILER OPERATION:

This boiler must only be operated by a responsible adult who has been instructed in, understands, and is aware of the boiler's operating conditions and effects.

HEALTH AND SAFETY

The appliance contains no asbestos and no substances have been used in the construction process that contravene the COSHH Regulations (Control of Substances Hazardous to Health Regulations 1988).

COMBUSTION AND CORROSIVE MATERIALS

Do not store or use any combustible materials (paper, thinners, paints etc.) inside or within the vicinity of the appliance.

The combustion air must be free from chemically aggressive substances which can corrode the appliance and invalidate any warranty.

FITTING AND MODIFICATIONS

Fitting the appliance and any controls to the appliance may only be carried out by a competent engineer in accordance with these instructions and the relevant Installation Regulations.

Flue systems must not be modified in any way other than as described in the fitting instructions. Any misuse or unauthorised modifications to the appliance, flue or associated components and systems could invalidate the warranty. The manufacturer accepts no liability arising from any such actions, excluding statutory rights.

IMPORTANT

The service engineer must complete the Service Record at the back of the manual after each service.

SERVICING:

Advise the user to have the system regularly serviced by a competent, qualified engineer (such as OFTEC registered personnel) using approved spares, to help maintain the economy, safety and reliability of the appliance.

INSTALLATION REGULATIONS

Failure to install appliances correctly could lead to prosecution.

COMPLYING WITH THE BUILDING REGULATIONS:

The boiler and flue form part of the controlled services for the building. It is law that all controlled services for buildings must comply with building regulations. You must be able to satisfy your Local Authority Building Control Body (LABC) that the work carried out concerning the installation and commissioning of the heating appliances has been carried out to a satisfactory standard.

OFTEC operate a competent persons scheme and registered installers are able to certify that their work complies with building regulations.

Under the scheme:

- OFTEC must be informed about every installation.
- OFTEC will issue a building regulations compliance certificate to the householder and will notify LABC.

OFTEC provide controlled document forms CD10 and CD11 for use during installation and commissioning respectively.

Other organisations operate self-certification schemes e.g. NAPIT and BESCA Ltd. and it may be possible for installers who are members of these organisations to self certify their work.

Alternatively you must submit a building control notice to the LABC before installing any boiler.

The LABC will then arrange regular inspection visits during the work to ensure that the installation complies with the regulations.

The appliance must be installed by a competent person. The person installing the appliance should be aware of the Health and Safety at Work Act and take appropriate action to ensure that the regulations are adhered to. In order to give optimum efficiency and trouble free operation the appliance must be commissioned by a qualified OFTEC engineer.

The compliance with a British Standard does not, in itself, confer immunity from legal obligations. In particular the installation of this appliance must be in accordance with the relevant requirements of the following British Standards and regulations in respect of the safe installation of equipment.

BS 5410: part 1: Code of practice for Oil Fired Boilers.

The Building Regulations Part J and L1 England and Wales; Part F and Part J Section III Scotland;

Part L and Part F Northern Ireland.

Local water company bye-laws.

The Control of Pollution (Oil) Regulations.

OFTEC Standards.

Where no specific instruction is given, reference should be made to the relevant codes of practice.

2 PRODUCT INFORMATION

2.1 ROOM SEALED VERTICAL FLUE COMPONENTS

80/125mmØ RS Vertical flue kit comprising: Part No.: 7 716 190 032	
1	Terminal assembly
2	Elbow 80/125mmØ
3	Installation manual
4	Drill pack, containing: 3.3mm HSS jobber's drill and solvent free grease sachet
5	Clamp bracket
6	Pipe clamp with screws, washers and wall plugs
7	Fire stop plate with screws, washers and wall plugs

Table 4 80/125 Vertical flue components

100/150mmØ RS Vertical flue kit comprising: Part No.: 7 716 190 059	
1	Terminal assembly
2	In-line 80/125 to 100/150mmØ adapter
3	Elbow 80/125mmØ
4	installation manual
5	Drill pack, containing: 3.3mm HSS jobber's drill and solvent free grease sachet
6	Clamp bracket
7	Pipe clamp with screws, washers and wall plugs
8	Fire stop plate with screws, washers and wall plugs

Table 5 100/150 Vertical flue components

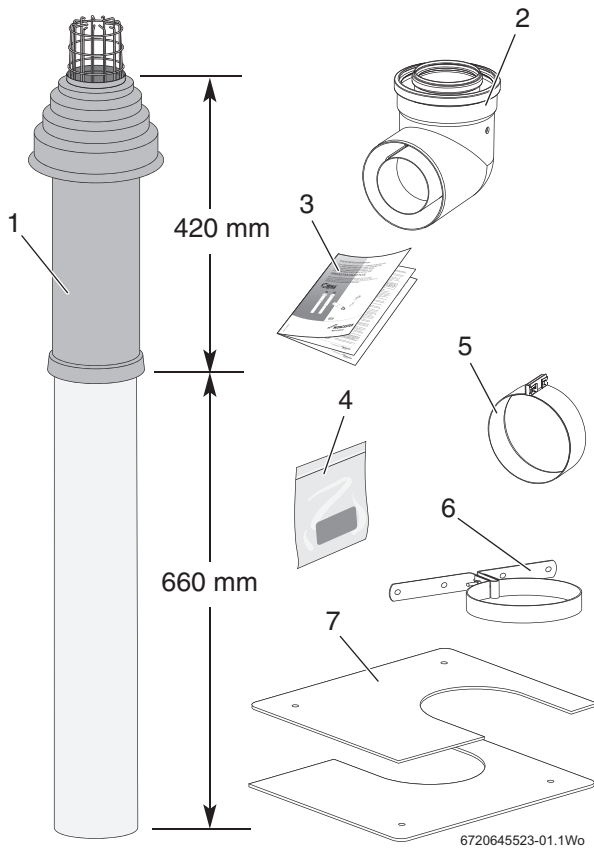

Fig. 1 80/125 RS Vertical flue kit

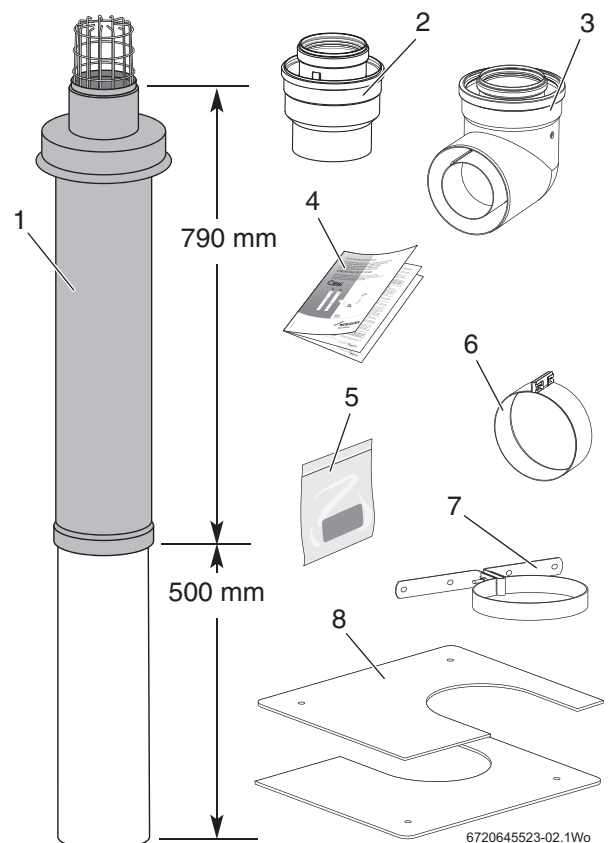

Fig. 2 100/150 RS Vertical flue kit

2.2 ROOM SEALED TELESCOPIC HORIZONTAL FLUE COMPONENTS

80/125mmØ RS Telescopic horizontal flue kit comprising: Part No. 8 716 114 231 0 or 8 716 114 232 0	
1*	Terminal assembly
2	Installation manual
3	Clamp bracket
4	Wall plates with screws, washers and wall plugs
5	Drill pack, containing: 3.3mm HSS Jobber's drill, No.8 x 13mm self tapping screws x 3 and solvent free grease sachet
6	Wall seal
* Flue terminal lengths of less than 350mm are achieved by shortening the inner terminal section.	

Table 6 RSF Telescopic flue components

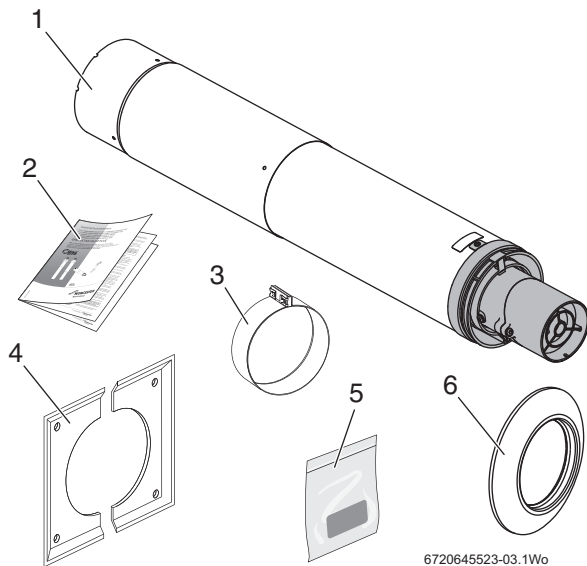

Fig. 3 Telescopic components

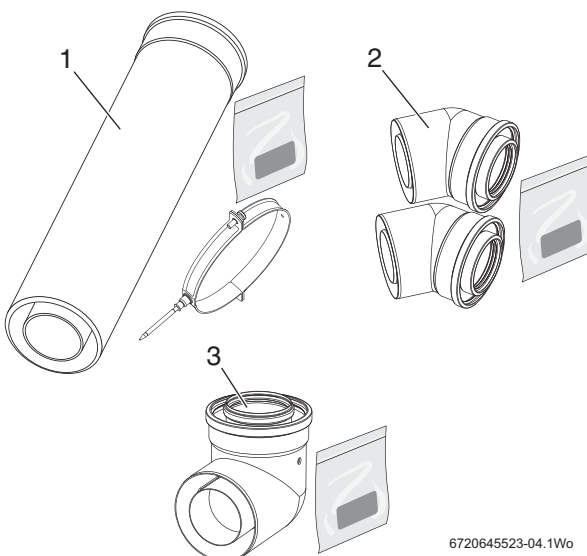

Fig. 4 RSF Extension components

2.3 ROOM SEALED FLUE EXTENSION COMPONENTS

80/125mmØ RS Flue extension comprising: Part No.: 7 716 190 033	
1	<ul style="list-style-type: none"> • Extension tube - 1000mm • Pipe clamp with screws and washers • Solvent free grease pack, containing: No. 8 screws x 2 and grease sachet
80/125mmØ RS Flue extension comprising: Part No.: 7 716 190 097	
1	<ul style="list-style-type: none"> • Extension tube - 600mm • Pipe clamp with screws and washers • Solvent free grease pack, containing: No. 8 screws x 2 and grease sachet
80/125mmØ RS 45° Elbow comprising: Part No.: 7 716 190 035	
2	<ul style="list-style-type: none"> • 45° Elbow x2 • Solvent free grease pack, containing: No. 8 screws x 2 and grease sachet
80/125mmØ RS 90° Elbow comprising: Part No.: 7 716 190 034	
3	<ul style="list-style-type: none"> • 90° Swept elbow • Solvent free grease pack, containing: No. 8 screws x 2 and grease sachet
100/150mmØ RS Flue extension comprising: Part No.: 7 716 190 045	
1	<ul style="list-style-type: none"> • Extension tube - 1000mm • Pipe clamp with screws, washers and wall plugs • Solvent free grease pack, containing: No. 8 screws x 2 and grease sachet
100/150mmØ RS 45° Elbow comprising: Part No. 7 716 190 047	
2	<ul style="list-style-type: none"> • 45° Elbow x2 • Solvent free grease pack, containing: No. 8 screws x 2 and grease sachet
100/150mmØ RS 90° Elbow comprising: Part No. 7 716 190 046	
3	<ul style="list-style-type: none"> • 90° Swept elbow • Solvent free grease pack, containing: No. 8 screws x 2 and grease sachet

Table 7 Extension components

3 PRE-INSTALLATION

3.1 FLUE TERMINAL POSITIONS

All measurements in millimetres

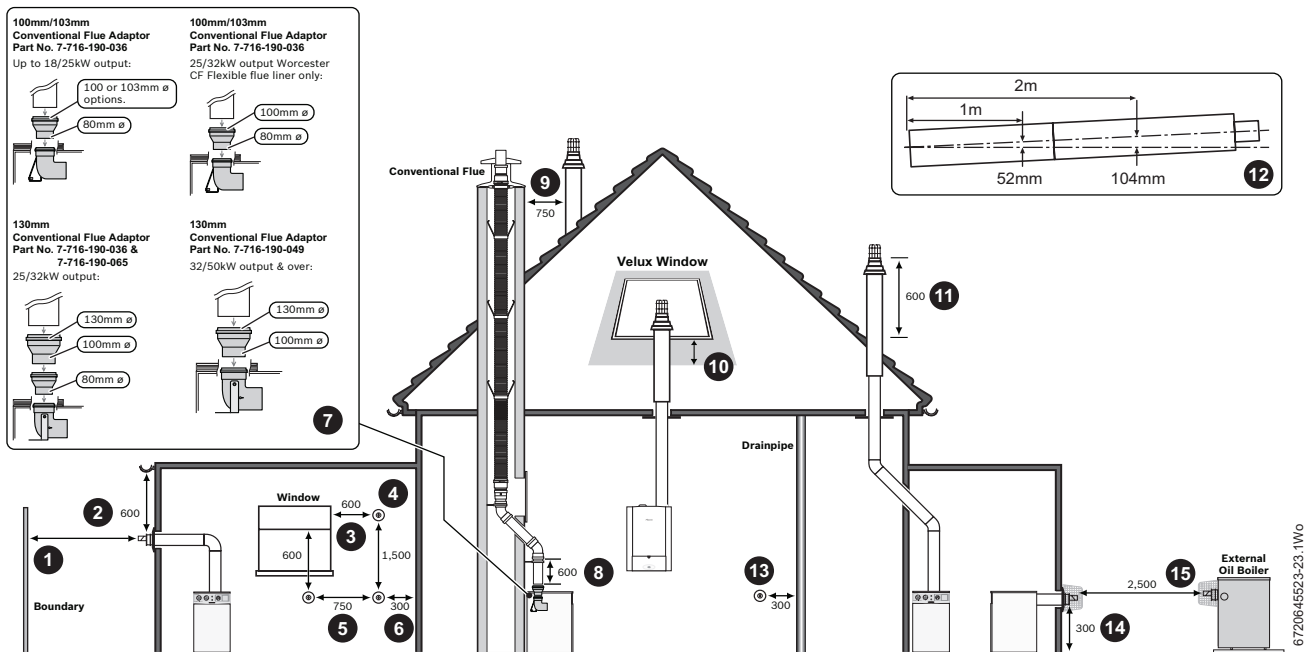

Fig. 5 Flue terminal positions



NOTE:

- ▶ All measurements are the minimum clearances required.
- ▶ Use suitable brackets and fittings to support the flue at approximately one metre intervals and at a change of direction.
- ▶ Terminals must be positioned so to avoid combustion products entering the building.
- ▶ In spite of the dimensions given here, the terminal must not be closer than 300mm to combustible material, in the case of a thatched roof double this dimension.
- ▶ Terminals must be positioned so to avoid products of combustion accumulating in stagnant pockets around the building or entering the building.
- ▶ Terminals must be at least 1.8m from an oil storage tank unless a wall with of at least 30 minutes fire resistance and extending 300mm wider and higher than the tank is between the tank and the terminal.

KEY TO ILLUSTRATION

1. 600mm distance to a boundary, unless it will cause a nuisance. BS 5410: Part 1 recommends that care is taken when siting terminals in relation to boundaries.
2. 600mm below eaves, balconies, this can be reduced to 75 mm, as long as the flue terminal is extended to clear any overhang.
3. 600mm horizontally or vertically to an opening, air brick or opening window.
4. 1,500mm vertically from a terminal on the same wall.
5. 750mm horizontally from a flue on the same wall.
6. 300mm to an internal or external corner.
7. Details of conventional flue adapters.
8. Minimum 600mm straight flue before any bend on a conventional flue.
9. 750mm between a vertical structure and a flue terminal.
10. 1000mm below a Velux window, 300mm above or to either side of the Velux window or any opening on a sloping roof.
11. 600mm above the highest point of an intersection with a roof.
12. Any flue must fall back towards the boiler by 3° or 52mm for every metre of flue so that the condensate drains back to the boiler for disposal.
13. 300mm to any vertical sanitary pipe work or drain pipe.
14. Flue clearance must be at least 300mm above ground or balcony level. Terminal guards must be fitted if the flue is less than 2 metres from the ground or if a person could come into contact with the flue terminal.
15. 2500mm between terminals facing each other.

3.2 FLUE SYSTEMS IN VOIDS

When installing a new flue system consider the following information.



CAUTION: Flue systems in ceilings or roof voids.
Access must be provided for service and inspection:

- ▶ Voids containing concealed flues must have at least one inspection hatch no less than 300mm square.
- ▶ Flue joints within the void must not be more than 1.5m from the edge of the inspection hatch.
- ▶ Inspection hatches should be located at changes of flue direction. If this is not possible, bends should be viewable from both directions.

FLUE SYSTEMS IN CEILINGS OR ROOF VOIDS

When installing a flue system in a ceiling or roof void, the following points must be observed:

1. Access points for inspection of the flue system must be sufficiently sized for visual inspection, particularly at any joint in the flue system.
2. The flue system must not pass through a neighbouring property, as access may not be possible at the time of inspection.
3. Any access must not contravene any other building regulations or fire regulations. Refer to Building Regulations Approved Documents B, L and E.
4. The access panels must be no less than 300mm square. Larger access panels can be considered if the whole flue system needs to be viewed.
5. The flue system must be adequately supported at regular intervals, approximately every one metre.

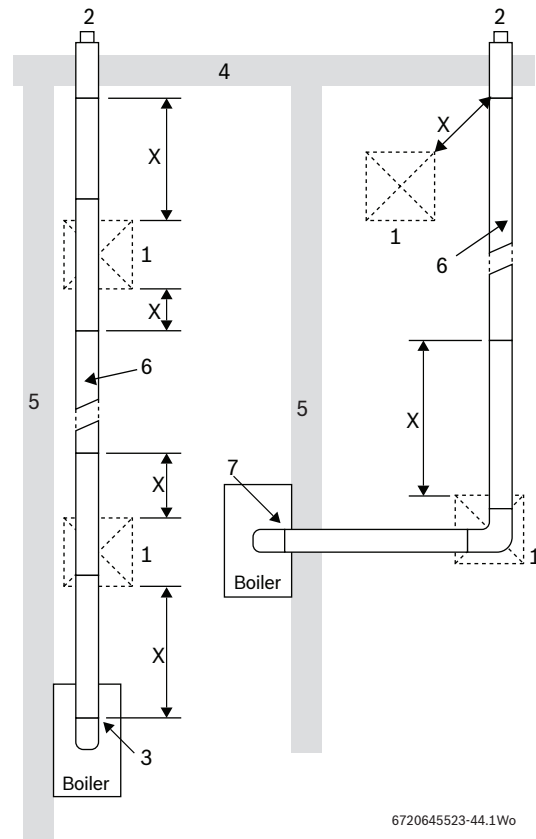

6720645523-44.1Wo

Fig. 6 Flues in voids

X	This dimension must not be more than 1.5 metres
1	Inspection hatch
2	Flue terminal
3	Concealed flue connection
4	External wall
5	Internal wall
6	Any intervening joints must be visible within 1.5 metres of the inspection hatch
7	Accessible flue connection

Table 8 Key to figure 6

ANNUAL INSPECTION

When the flue system is inspected under the annual service, the engineer must inspect and confirm that:

- ▶ the flue system is continuous without any breaks.
- ▶ all joints in the flue system are sound and correctly assembled according to the manufacturers instructions.
- ▶ the flue has a fall of at least 3° (52 millimetres per metre) back to the boiler.

4 INSTALLATION

4.1 ROOM SEALED FLUE MEASUREMENT



NOTE: CONDENSATE DISPOSAL

- ▶ All horizontal flue sections must rise by at least 52mm per metre away from the boiler to ensure that the condensate flows back into the boiler for safe disposal via the condensate waste pipe.



Cutting the horizontal flue to an exact measurement is not normally required as the telescopic flue terminal can allow for some adjustment.

HORIZONTAL FLUES

The determination of the effective flue length (L) is made by measuring the flue path from the boiler casing to the outside wall and adding the effective length of any bends used.

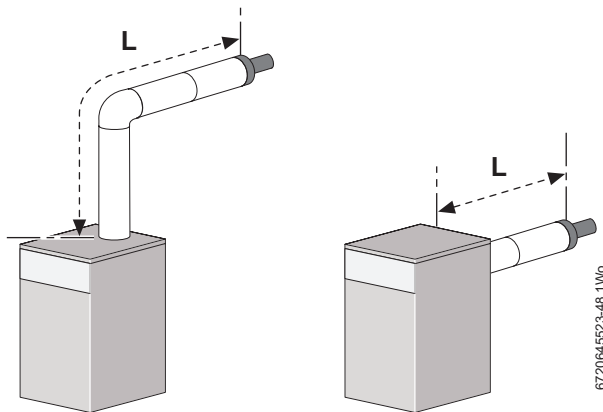

Fig. 7 Effective length - horizontal

VERTICAL FLUES

The determination of the effective flue length (L) is made by measuring the flue path from the boiler casing to the outside of the roof, plus at least 600mm of flue that must project beyond the roof.

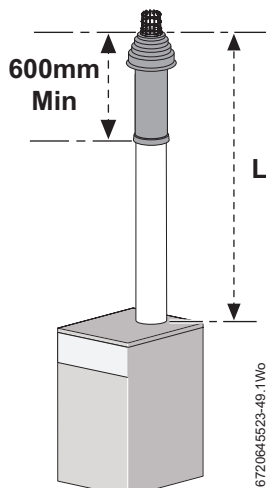

Fig. 8 Effective length - vertical

Greenstar Appliance	Model	Maximum effective flue length (L) in metres				Flue Ø (mm)
		High level horizontal	Low level horizontal rear	Low level horizontal side	Vertical	
Danesmoor models	18/25	5	6	5	12	80/125
Heatslave	18/25	5	6	5	12	80/125
Camray	18/25	5*	6*	5*	8	80/125
		-	-	-	10*	100/150
Camray models	12/18	2	4	3	8	80/125
	25/32	2	4	3	-	80/125
	-	-	-	-	8	100/150
Wall hung Danesmoor	12/18 & 18/25	4	4	4	6	80/125
Heatslave models	12/18 & 25/32	2	4	3	6	80/125

Table 9 Maximum flue lengths

*** Flue damper required!**

Refer to Table 13 for more information

4.1.1 DETERMINE THE EFFECTIVE FLUE LENGTH (L)

1. Measure the length of the flue path required from the flue opening outside the building to the boiler outer casing.
2. Add the “effective length” of each bend to the straight length of flue. Adding bends to the flue system reduces the actual flue length available.

Flue bends are rated as an effective length of flue:

Bend	Effective length
90°	1 metre
45°	0.5 metres

Table 10

Ensure that the effective length does not exceed the values stated in table 9 for your boiler.

The flue will project outside the building by the measurements shown in table 11

Flue termination	Minimum projection
Horizontal	120mm
Vertical	600mm (minimum)

Table 11

4.1.2 ACTUAL FLUE LENGTH

1. Add dimension “X” to the effective flue length (L) to allow the flue to fit to the outlet/elbow inside the boiler casing.
2. Refer to figure 9 and table 12 for dimension X for flue outlet options 1, 2, 3 or 4.

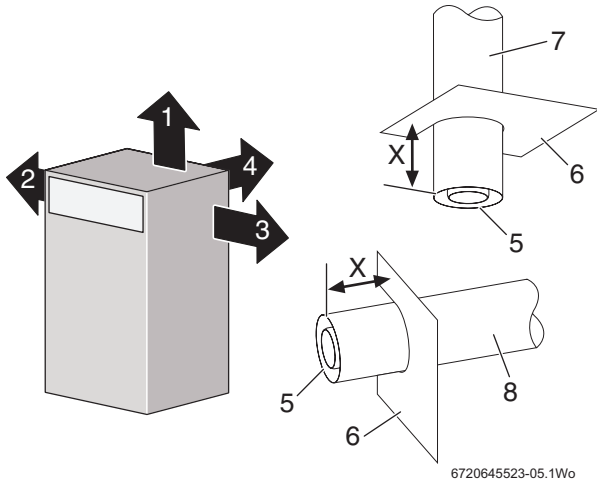

6720645523-05.1Wo

Fig. 9 Fluing options from the boiler

Flue outlet	Length X (mm)		
	Danesmoor	Heatslave	Camray
1	40	40	30
2	100	250	100
3	100	100	100
4	210	210	270
5	Flue outlet		
6	Boiler outer casing		
7	Vertical flue or extension		
8	Horizontal flue or extension		

Table 12 Key to figure 9

4.2 FLUE ADJUSTMENT AND CUTTING



Ensure that the TOP label of both sections are aligned before securing the two parts at the required length.

4.2.1 TELESCOPIC FLUE ADJUSTMENT

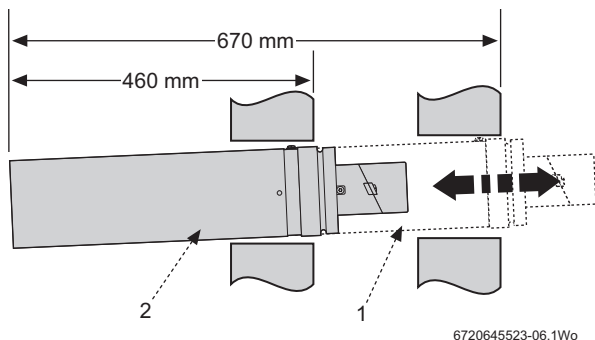

Fig. 10 Standard telescopic flue

Extend the tube [1] by withdrawing from tube [2] to achieve a flue length required between 460 - 670mm

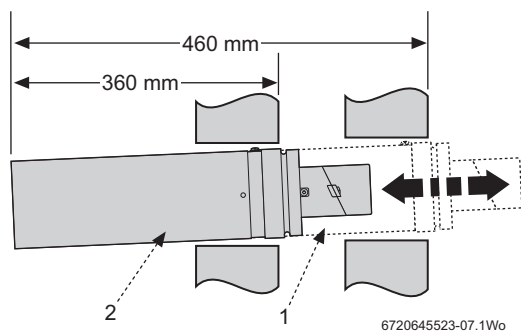

Fig. 11 Short telescopic flue

Extend tube [1] by withdrawing from tube [2] to achieve the flue length required, between 360- 460mm.

Secure with screw provided and seal joint with the aluminium tape supplied.

4.2.2 REDUCING THE TELESCOPIC FLUE LENGTH

The flue terminal MUST be fitted with the 'TOP' label uppermost to allow the correct fit and use of the plume management system.

- ▶ Slide terminal section [2] from the terminal assembly [1] and discard.

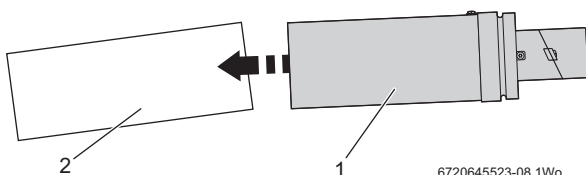

Fig. 12 Reducing the telescopic flue

Reducing the telescopic flue length further:

- ▶ Mark the length required for the terminal as shown in figure 13 (min. 160mm) and cut square, taking care not to damage the tubes.
- ▶ Remove any burrs and chamfer the outer edge of the tubes to assist ease of connection and prevent seal damage.



The aluminium tape is not required when reducing the terminal.

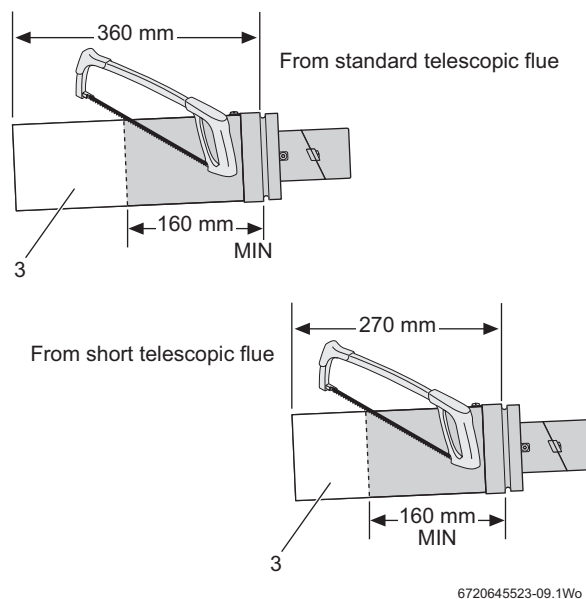

Fig. 13 Reducing the flue further

4.2.3 REDUCING FLUE LENGTH

- ▶ Mark the extension tube to the required distance, measuring from the socket end and cut the tube square, taking care not to damage the tubes.
- ▶ Remove any burrs and chamfer the outer edge of the tubes to ease the connection and prevent damage to the seals.

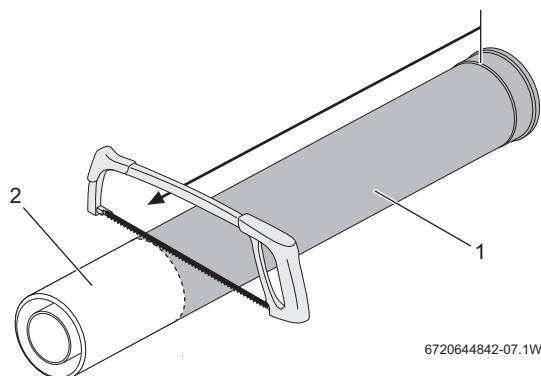

Fig. 14 Reducing flue length

4.3 ROOM SEALED FLUE FITTING

NOTE: Flue assembly

- ▶ To ease assembly of the flue components, grease seals lightly with the solvent free grease supplied.
- ▶ Check all the seals are seated properly in the grooves provided and are in good condition.

FITTING A STRAIGHT FLUE EXTENSION TO THE BOILER OUTLET

1. Remove the bracket retaining screws.
2. Remove the bracket and discard.

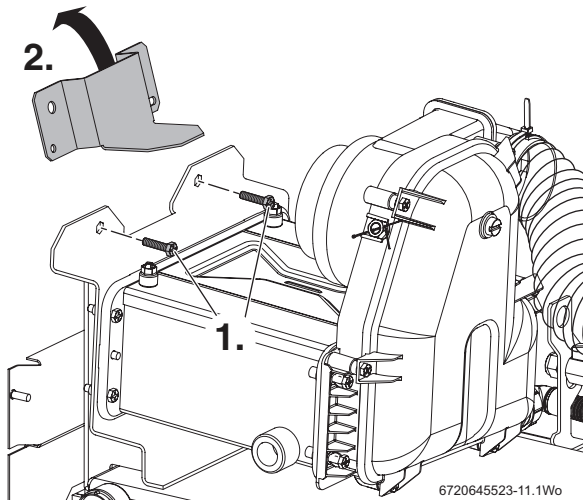

Fig. 15 Discard bracket

1. Ensure that the seal [1] is correctly seated and grease has been applied to ease assembly.
2. Slide the clamping collar [3] over the flue extension [2] and mate the extension tube to the boiler outlet. Ensuring that the inner tube slides fully into the seal of the boiler outlet.
3. Position the clamp over the extension tube and boiler outlet and tighten firmly.

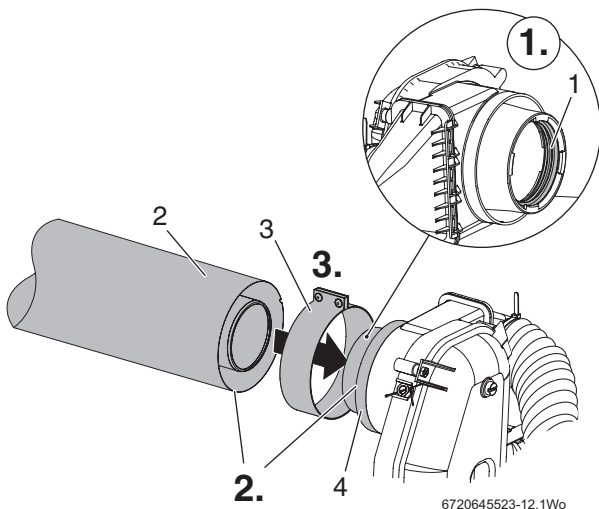

Fig. 16 Flue fitting

FLUE DAMPER

WARNING: Fitting the flue damper

- ▶ Failure to fit the flue damper, when required, will effect the performance of the boiler and may cause “lockouts”

i The flue damper is only fitted to the Greenstar Camray 18/25 models and then only according to flue length.

Greenstar Camray 18/25 models			
Flue type			
Vertical 100/150	High level horizontal	Low level horizontal rear exit	Low level horizontal side exit
Fit a damper at the following effective flue lengths			
All	Greater than 2 metres	Greater than 4 metres	Greater than 3 metres

Table 13 Damper required

The CO₂ must be readjusted when a damper is used, refer to the relevant Installation Commissioning & Servicing manual for the Camray 18/25 boiler.

18kW	21.5kW	25kW
11%	11.5%	no change

Fit the flue damper into the flue as shown in figure 17. Ensure that the rubber seal is fitted into the inner tube.

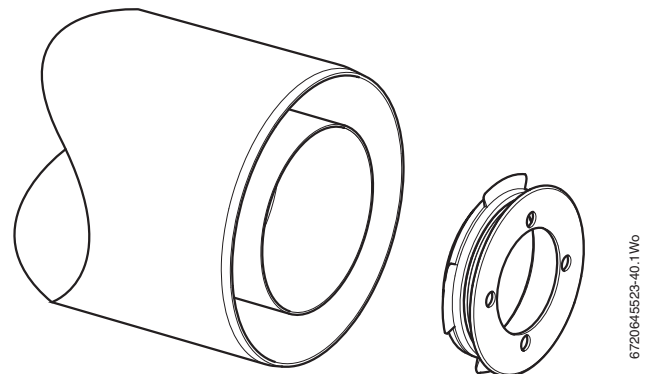

Fig. 17 Flue damper detail

Insert the flue damper into the inner flue tube of the 90° elbow or straight extension and fit the flue as detailed in figure 16 or figure 19 as required.

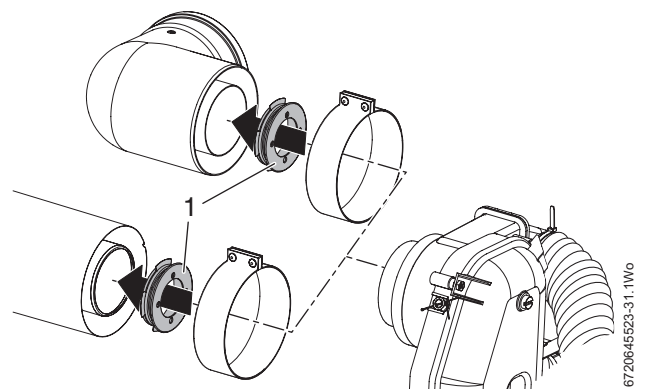

Fig. 18 Flue damper fitting

FITTING AN ELBOW TO THE BOILER OUTLET

1. Ensure that the seal [1] is correctly seated and grease has been applied to ease assembly.
2. Loosen the nuts and bolts securing the retaining bracket [2], but do not remove.
3. Slide the clamping collar [4] over the elbow [3] and mate the elbow to the boiler outlet. Ensuring that the inner tube slides fully into the seal of the boiler outlet.
4. Align the elbow to the direction of the flue path, either left, right or vertically.
5. Position the clamp over the elbow and boiler outlet and tighten firmly.

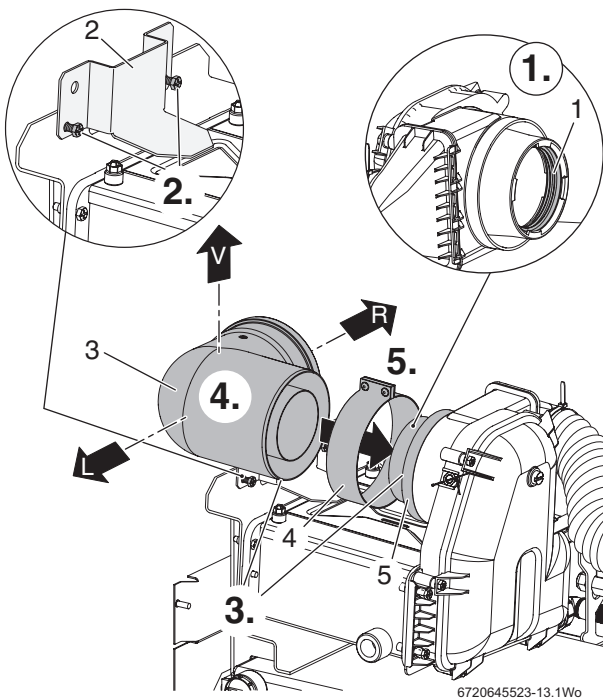

Fig. 19 Flue bend fitting

1. With the elbow in the required position.
2. Re-secure the retaining bracket [1]

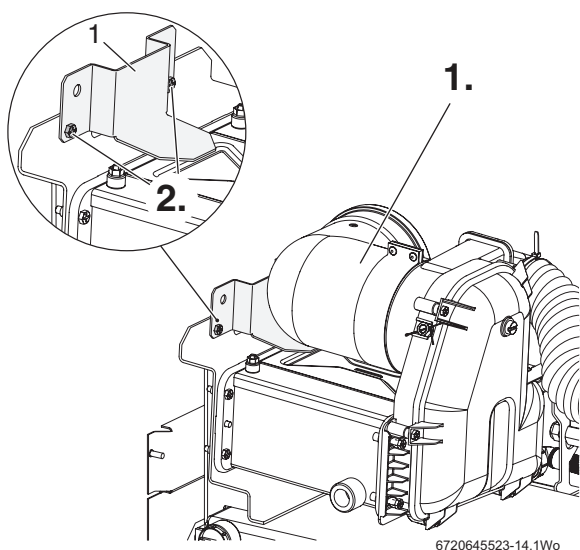

Fig. 20 Securing bracket

4.4 ROOM SEALED FLUE TERMINAL & EXTENSIONS

NOTE: Flue assembly

- ▶ To ease assembly of the flue components, grease seals lightly with the solvent free grease supplied.
- ▶ Check all the seals are seated properly in the grooves provided and are in good condition.
- ▶ All flue joints must be sealed to prevent leakage of condensate and flue products.

WARNING: Support the flue correctly.

- ▶ Do not allow the boiler to support the weight of the flue.

4.4.1 VERTICAL TERMINALS

i Specially designed roof flashing for the 80/125 vertical flue are available under the following numbers:
 7 716 191 091 for pitched roof applications
 or
 7 716 191 090 for flat roof applications

1. Fit the roof flashing [1], not supplied, and weatherproof terminal exit to roof.
2. Fit flue terminal [2] through the flue opening in the roof flashing, ensuring that the flue extends beyond the roof by the distance shown, as a minimum. The collar on the external part of the flue is designed to rest on top of the roof flashing.
3. Secure the fire stop plates [3] to the ceiling above the boiler with the screws provided.

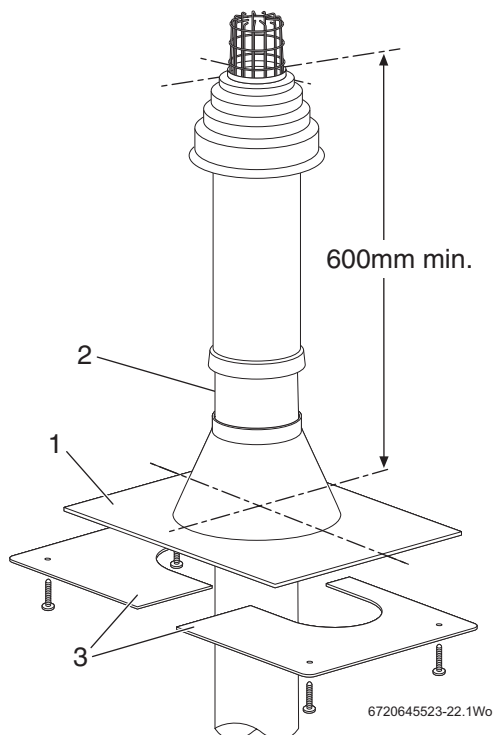

Fig. 21 Vertical flue assembly

- ▶ Fit the flue support clamps [1] at regular intervals to support the weight of the flue.
- ▶ If a 100/150 flue is to be employed, the adapter [4] from 80/125 to 100/150 must be fitted to the elbow. Ensure all seals are in place and lightly grease with the solvent free grease provided. Ensure that the adapter is firmly fitted into the elbow.
- ▶ Orient elbow [3] in the required direction and fit flue firmly into the elbow.
- ▶ Secure flue tube [2] with the support clamps.

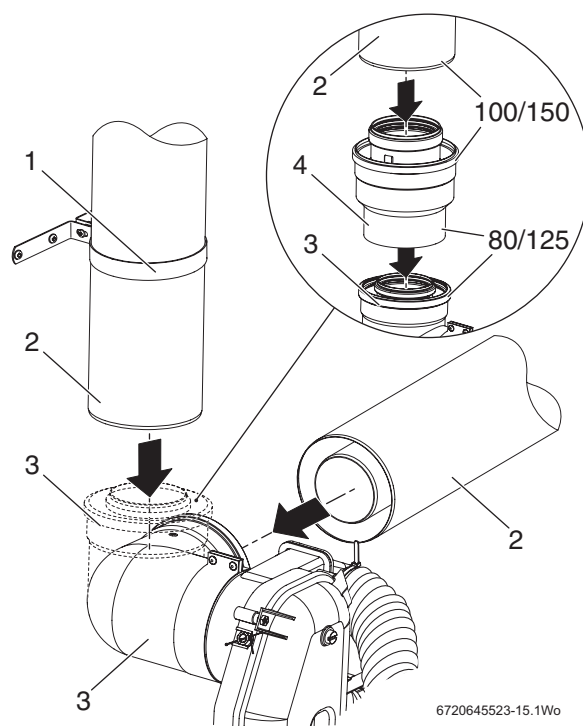

Fig. 22 Flue component assembly

WARNING: Drilling

▶ Do not drill through the inner flue tube

1. Drill holes, using the jobber's drill bit, approximately 180° apart through the elbow and into the outer flue tube, taking care NOT to drill the inner flue tube.
2. Secure the flue to the elbow using the self tapping screws provided.

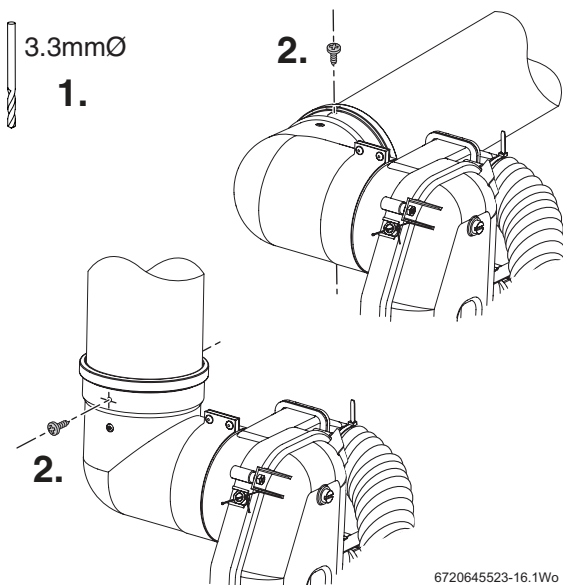

Fig. 23 Securing the flue

4.4.2 HORIZONTAL TERMINALS

Fit the terminal through the flue opening in the wall to the outside of the building by the distance shown. Ensure that the flue is correctly rotated so that the "TOP" label at the top.

1. Slide on the outer wall seal, locating the ridge on the seal with the groove on the terminal.
2. Position terminal through the flue opening in the wall to the outside of the building by the distance shown.
3. Set the telescopic flue to the required length and secure with the screws provided and seal the joint with the aluminium tape provided.
4. Attach the other flue extensions/elbows as required.
5. Secure the fire stop plates to the wall with the screws provided

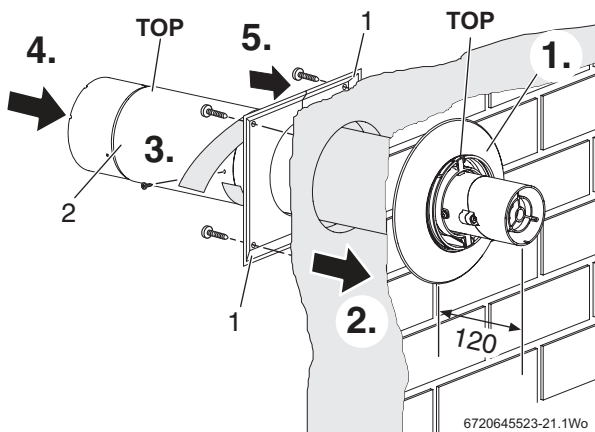

Fig. 24 Telescopic flue installation

4.4.3 EXTENSIONS

▶ Referring to figure 25 and 26 slide the support clamps (1) onto the additional flue extensions (2).

1. Working from the boiler, fit the support clamps (1), to take the weight of the flue elbows and extensions (2).
2. Drill two holes with the jobber's drill bit provided (180° apart if possible) through the outer flue tube (L) on each flue joint, taking care NOT to drill the inner flue tube, and secure with screws provided.

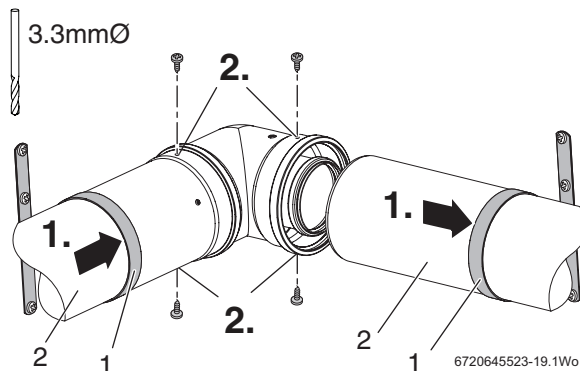

Fig. 25 Extensions employing elbows

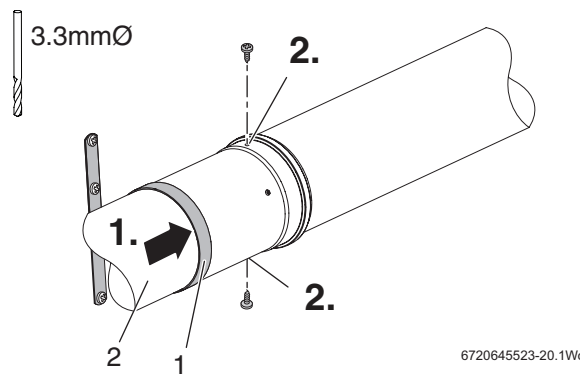

Fig. 26 Straight extensions

4.5 WALL MOUNTED OIL BOILERS

4.5.1 MAXIMUM FLUE LENGTHS

Measure the flue length (L) required from the flue opening outside the building to the boiler outer casing.

Danesmoor Wall Hung 12/18 & 18/25	Horizontal	4000mm
	Vertical	6000mm

Add the dimension for the terminal projecting outside the building:

- 120mm for a horizontal terminal
- 600mm (min) for a vertical terminal

4.5.2 VERTICAL FLUE

1. Refer to figure 27 and apply a light smear of grease to the flue outlet seal to aid fitting the vertical adapter.
2. Fit the vertical adapter [1] to the top of the boiler with the flat edge facing left.
3. Secure the adapter [1] with the screws [2] provided.
4. Ensure that the seal is fitted correctly in the vertical adapter [1] and apply a light smear of grease to the seal to aid fitting the vertical adapter.
5. Fit the vertical flue to the vertical adapter:
 - Slide the clamping collar [3] over the flue tube [4].
 - Fit the flue firmly into the adapter.
 - Ensure that the edge of the flue tube [4] coincides with the outer edge of the vertical adapter [1] and tighten the clamping collar to secure.

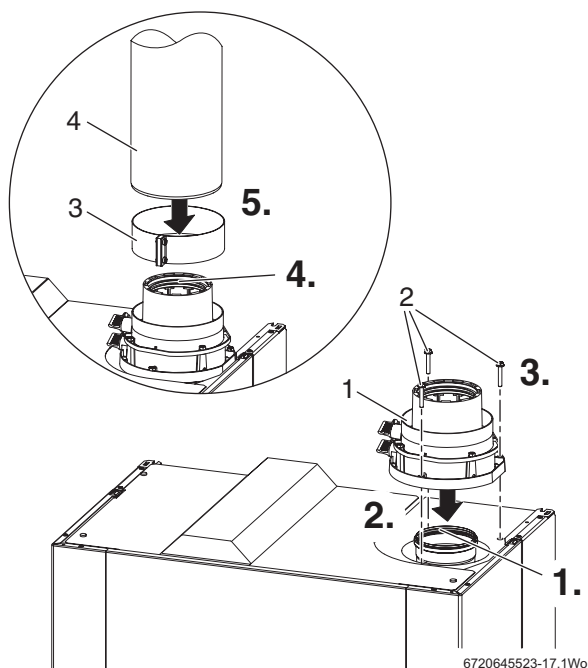

Fig. 27 Vertical flue

4.5.3 HORIZONTAL FLUE

- ▶ Fit the vertical adapter as described in section 4.5.2 Vertical Flue.

1. Refer to figure 28 and ensure that the seal is fitted correctly in the vertical adapter and apply a light smear of grease to the seal to aid fitting the vertical adapter.
2. Fit the elbow to the vertical adapter:
 - Slide the clamping collar [1] over the elbow [2] and fit the flue firmly into the adapter.
 - Orient the flue elbow in the desired direction.
 - Ensure that the edge of the elbow [2] coincides with the outer edge of the vertical adapter and tighten the clamping collar to secure.
3. Ensure that the seal is fitted correctly in the elbow and apply a light smear of grease to the seal to aid fitting the flue tube. Fit the flue tube/terminal [3] firmly into the elbow.
4. Using the 3.3mm jobber's bit, drill two holes approximately 180° through the elbow and into the outer tube of the flue, taking care NOT to drill the inner flue tube.
5. Using the self tapping screws provided, secure the flue to the elbow.

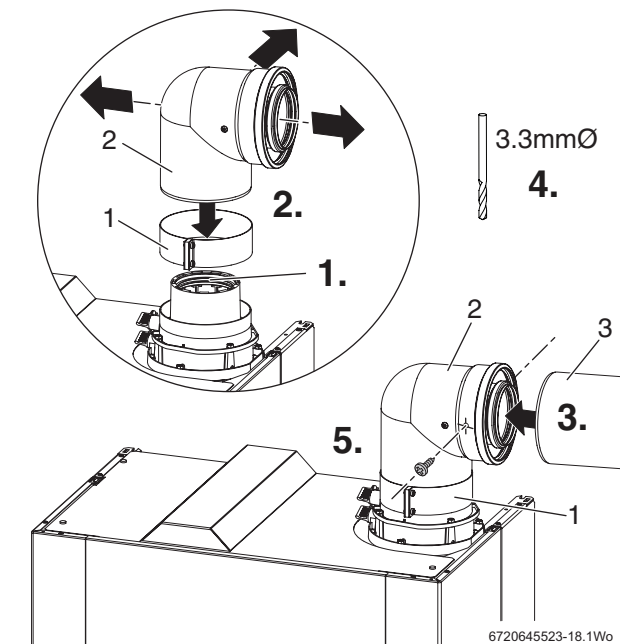

Fig. 28 Fitting the flue elbow

5 PLUME MANAGEMENT PRODUCT INFORMATION

5.1 PLUME MANAGEMENT SYSTEM COMPONENTS

PLUME MANAGEMENT COMPONENTS Ø 80mm PLUME MANAGEMENT KIT comprising: Part No.: 7 716 190 092	
1	90° bend
2	Extension 500mm
3	Outlet assembly
4	Clamp pack
5	Flue damper
6	Screw pack, containing: No.8 x 13mm self tapping screws x 2 and solvent free grease sachet

Table 14 80mm Plume management kit

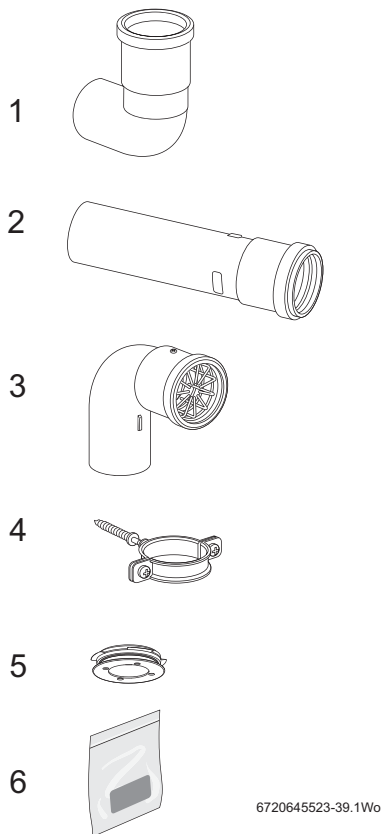

Fig. 29 Plume management kit components

EXTENSION COMPONENTS Ø 80mm EXTENSION comprising: Part No.: 7 716 190 093	
7	Extension 1000mm
8	Clamp pack
90° BEND comprising: Part No.: 7 716 190 095	
9	90° Bend
45° BEND comprising: Part No.: 7 716 190 094	
10	45° Bend x 2
80/125mmØ Terminal ring adaptor comprising: Part No.: 7 716 190 100	
11	Terminal ring

Table 15 Ø 80mm Extension

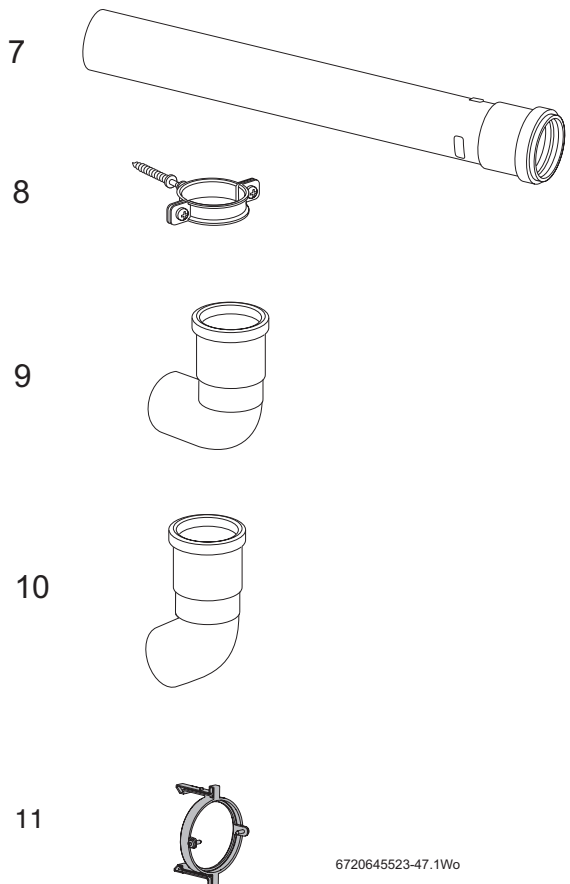

Fig. 30 Plume management extension components

6 PLUME MANAGEMENT

6.1 PRE-INSTALLATION

All measurements in millimetres

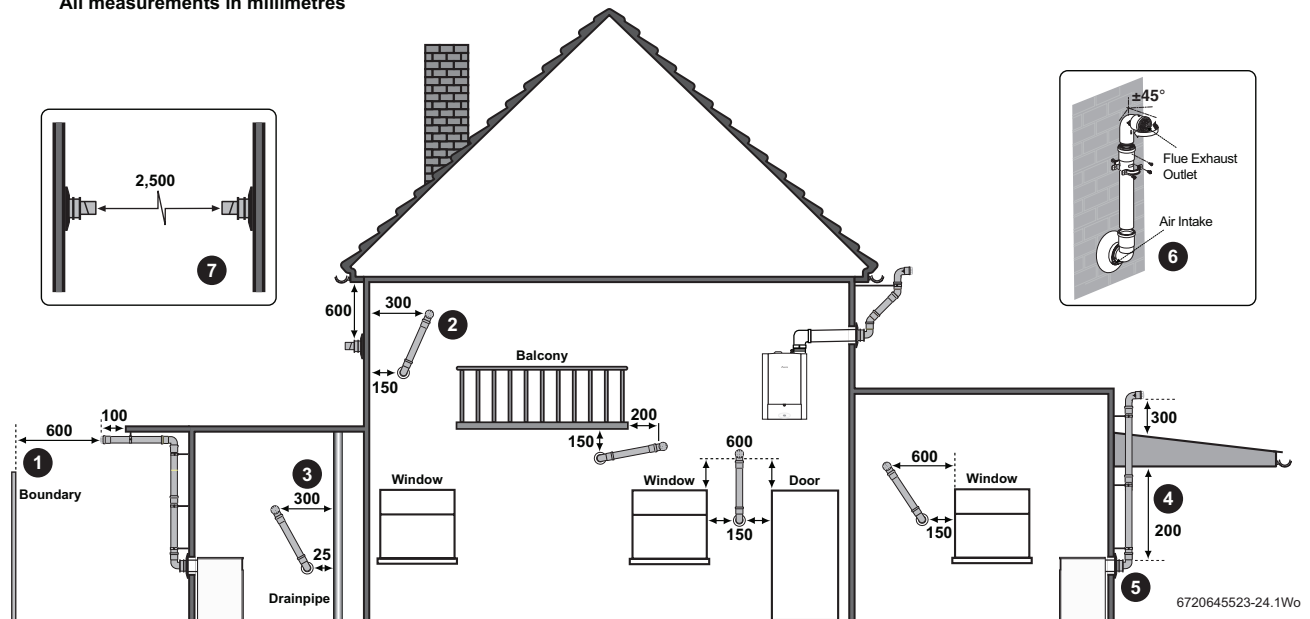

Fig. 31 Plume terminal positions



NOTE:

- ▶ All measurements are the minimum clearances required.
- ▶ Terminals must be positioned so to avoid combustion products entering the building.
- ▶ Support the flue at approximately one metre intervals and at a change of direction, use suitable brackets and fittings.

KEY TO ILLUSTRATION

1. 600 mm distance to a boundary, unless it will cause a nuisance. BS 5410: Part 1 recommends that care is taken when siting terminals in relation to boundaries.
2. Internal/external corners the air intake can be reduced to 150mm providing the flue exhaust outlet has a 300mm clearance.
3. Vertical sanitary pipe: 25mm to the flue air intake and 300mm to the flue exhaust outlet.
4. Clearance no less than 200mm from the lowest point of the balcony or overhang, installations in car ports are not recommended.
5. 1200mm from an opening in a car port on the same wall i.e. door or window leading into dwelling. 600mm to a surface facing a terminal.
6. Using a Plume Management Kit the air intake measurement can be reduced to 150mm providing the flue exhaust outlet has a 600mm clearance. Plume kits running horizontally must have a 10 degree fall back to the boiler for proper disposal of condensate. For details on specific lengths see relevant boiler Technical & Specification manual.
7. 2500mm between air intake and facing terminal.

6.2 PLUME MANAGEMENT OPTIONS & MEASUREMENT

NOTE: PLUME MANAGEMENT

- All plume management sections must rise away from the air inlet by a minimum of 173mm per metre (10°) to allow the condensate to drain back to the boiler.

The figure 32 shows the components required for typical plume management configurations.

PLUME MANAGEMENT KIT

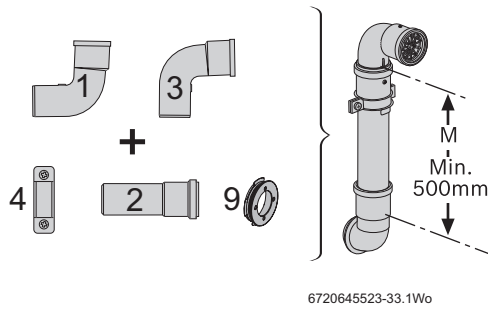

Fig. 32 Plume management components

1	90° bend
2	Extension 500mm
3	Outlet assembly
4	Clamp
9	Flue damper

Table 16 Key to figure 32

PLUME MANAGEMENT KIT PLUS OPTIONAL PARTS

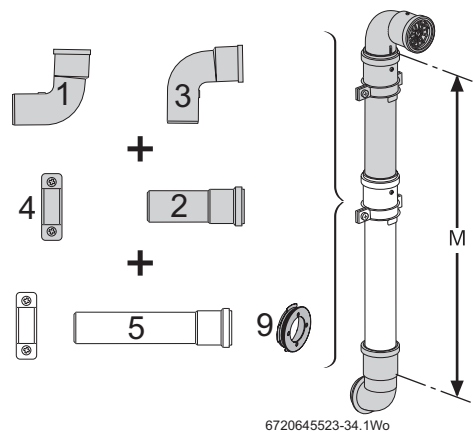

Fig. 33 Optional components in white

5	Extension tube 1000mm and Clamp
6	90° Bend
7	45° Bend

Table 17 Key to figure 33

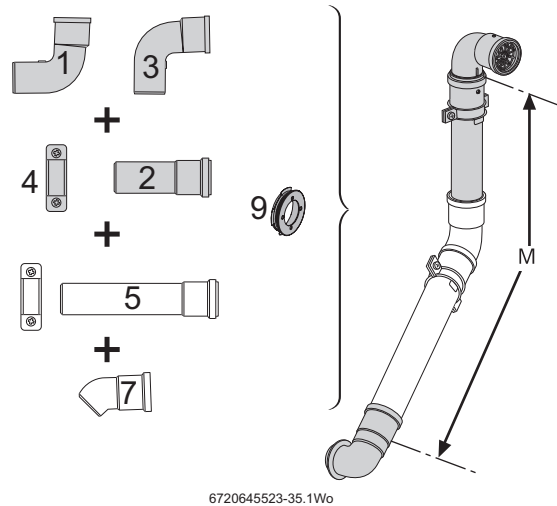

Fig. 34 Plume management with bend

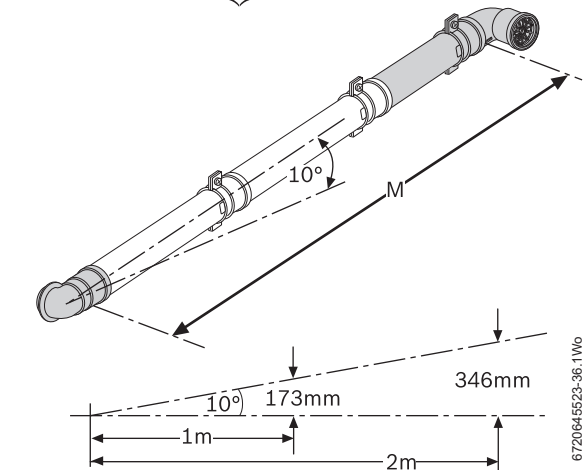
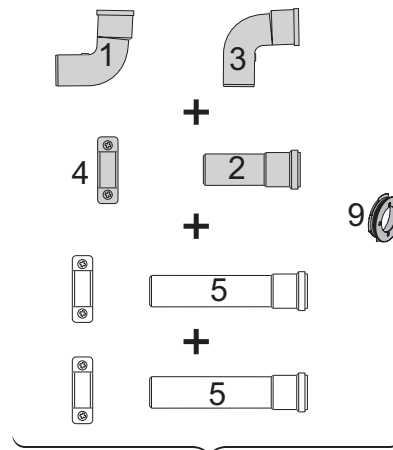

Fig. 35 Plume management with straight extension

NOTE: PLUME MANAGEMENT LENGTH

- Measurement M must be a minimum of 500mm and must not exceed the maximum stated in tables 19 to 24.

6.3 DETERMINE THE PLUME MANAGEMENT SYSTEM LENGTH

6.3.1 FLUE DAMPERS

WARNING: Fitting the flue damper

- ▶ Failure to fit the flue damper, when required, will effect the performance of the boiler and may cause “lockouts”

NOTE: CO₂ SETTINGS

- ▶ After fitting a plume management system and/or a flue damper, check and if necessary re-adjust the CO₂ settings as described in the Installation, Commissioning and Servicing manual for that boiler.

NOTE: Flue dampers

When plume management is utilised then a flue damper must be fitted to the following boilers:

- ▶ Camray 18/25
- ▶ Camray 25/32
- ▶ Danesmoor wall-mounted 18/25

CAMRAY BOILERS

The flue dampers for the Camray boilers can be fitted into the flue system as shown in section 4.3.

If the flue system has already been fitted then the Manifold Access Cover can be removed and the damper inserted into the flue inner tube. Take care not to damage the Flue Overheat Thermostat Phial.

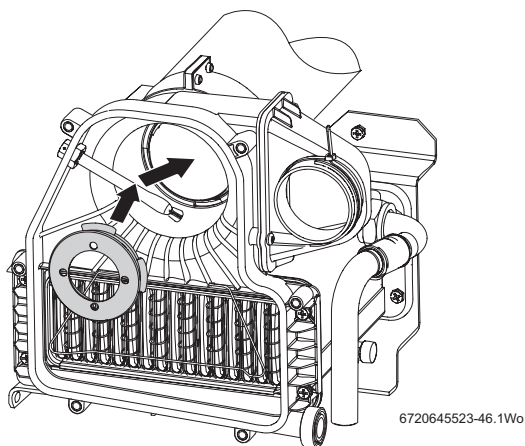

Fig. 36 Camray boiler detail

DANESMOOR WALL MOUNTED 18/25

The flue damper can not be fitted into the boiler and therefore must be fitted into the plume management system. Refer to figures Fig. 42 and Fig. 49 for flue damper fitting information.

6.3.2 PLUME MANAGEMENT

i The minimum plume length for all boilers stated on the front page of this manual is 500mm.

Refer to the following tables to determine the appropriate plume length (M) versus the flue length (L).

The flue length is the effective length (L), which includes the effective length of any elbows plus the straight flue lengths.

NOTE: Bends used in the system

- ▶ Please refer to the table that relates to your boiler to determine how many bends may be used in the Flue and Plume management system.
- ▶ The plume management system always employs two bends, the stated maximum bends that can be used are in addition to the first bend exiting the flue system and the terminal bend.

Effective lengths of elbows		
Bend	Flue	Plume
90°	1000mm	1000mm
45°	500mm	500mm

Table 18 Effective lengths of bends

6.3.3 PLUME MANAGEMENT LENGTH - FLOOR STANDING BOILERS

Once the length L is known, refer to the tables 19 to 24 opposite that relates to your boiler and select the appropriate plume management length (M).

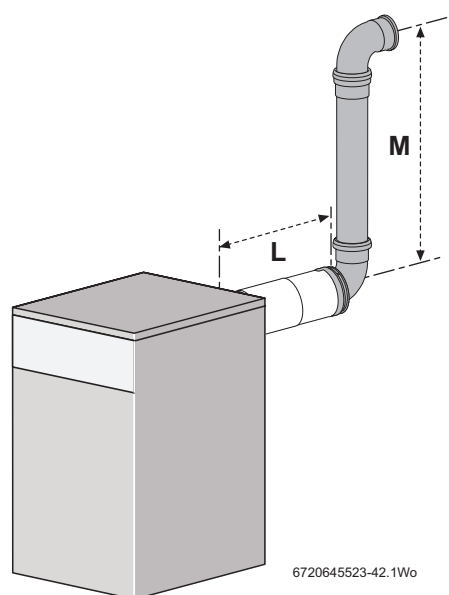

Fig. 37 PM length - floor standing boilers

PLUME MANAGEMENT VERSUS FLUE LENGTH- CAMRAY AND HEATSLAVE MODELS

The plume management system always employs two bends, the stated maximum bends that can be used are in addition to the first bend exiting the flue system and the terminal bend.

Greenstar Camray 12/18		
	Flue length (L)	Plume length (M)
	600 - 2000mm	500 - 5000mm
Bends	1	No additional

Table 19 Camray 12/18

Greenstar Camray 18/25		
A damper must be fitted if plume management is used, refer to Flue damper on page 12 or figure Fig. 36.		
	Flue length (L)	Plume length (M)
	160 - 2000mm	500 - 5000mm
	2001 - 3000mm	500 - 1500mm
	3001 - 4000mm	500 - 1000mm
Bends	maximum of 2	maximum of 3

Table 20 Camray 18/25

Greenstar Camray 25/32		
A damper must be fitted if plume management is used, refer to Flue damper on page 12 or figure Fig. 36.		
	Flue length (L)	Plume length (M)
	160 - 2000mm	500 - 5000mm
	2001 - 3000mm	500 - 3500mm
	3001 - 4000mm	500 - 2000mm
Bends	maximum of 2	maximum of 2

Table 21 Camray 25/32

Greenstar Heatslave 12/18, 18/25 & 25/32 Danesmoor 18/25		
	Flue length (L)	Plume length (M)
	160 - 2000mm	500 - 5000mm
	2001 - 3000mm	500 - 3500mm
	3001 - 4000mm	500 - 2000mm
Bends	maximum of 2	maximum of 3

Table 22 Heatslave 12/18, 18/25, 25/32 & Danesmoor 18/25

6.3.4 PLUME MANAGEMENT LENGTH - WALL MOUNTED BOILERS

Once the length L is known, refer to the tables below that relates to your boiler and select the appropriate plume management length (M).

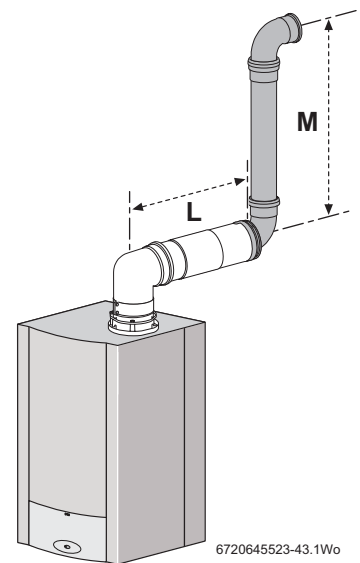

Fig. 38 PM length - Wall mounted boilers

PLUME MANAGEMENT VERSUS FLUE LENGTH - WALL MOUNTED DANESMOOR MODELS ONLY

The plume management system always employs two bends, the stated maximum bends that can be used are in addition to the first bend exiting the flue system and the terminal bend.

Greenstar Danesmoor WM 12/18		
	Flue length (L)	Plume length (M)
	600 - 2000mm	500 - 5000mm
Bends	maximum of 1	No additional

Table 23 Danesmoor WM 12/18

Greenstar Danesmoor WM 18/25		
A damper must be fitted when plume management is used. Refer to Fig. 42 and Fig. 49 for flue damper fitting information.		
	Flue length (L)	Plume length (M)
Horizontal flue	160 - 500mm	500 - 4000mm
	600 - 2000mm	500 - 3000mm
High level horizontal flue	3001 - 4000mm	500mm
Bends	maximum of 1	maximum of 2

Table 24 Danesmoor WM 18/25

6.4 MEASURING FOR A PLUME MANAGEMENT SYSTEM



All boilers have a maximum permissible plume management length, refer to page 21.

1. Measure the plume management flue (M) from the centre of terminal, along the required route to the centre of the plume outlet.

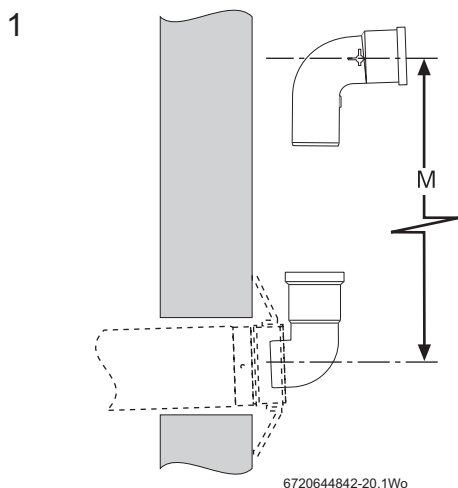

Fig. 39 Plume management length M

ADDITIONAL BENDS:

2. Adding bends to the plume management system reduces the actual plume management length. Each bend has an equivalent straight length and must be factored into the overall effective length.

- 90° bend is equivalent to 1000mm.
- 45° bend is equivalent to 500mm

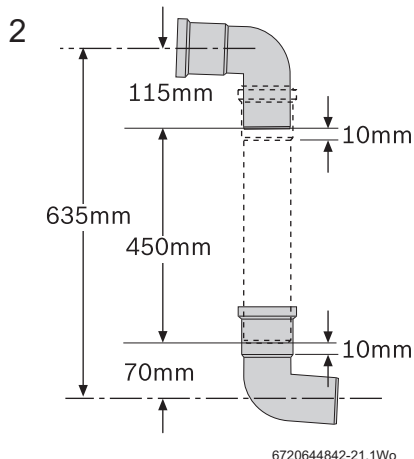

Fig. 40 Plume management bends

EXAMPLE:

Using two 45° bends will reduce the permissible length by 1000mm.

6.5 MODIFY NON TELESCOPIC FLUE TO ACCEPT PLUME MANAGEMENT



80/125mmØ Terminal ring adapter, Part number 7 716 190 100, order the item as an accessory.

A terminal ring adapter can be used to convert existing non telescopic flue to accept the plume management system.

1. Use two long screwdrivers to lift the clip on the flue terminal end and pull the terminal end forward slightly to release.
2. Repeat the procedure for the other clip, whilst holding the first clip in the released position.
3. Pull the terminal end forward to remove completely and discard.
4. Fit the plume management terminal ring adapter, ensuring that the two clips fully engage and are secure in the flue.

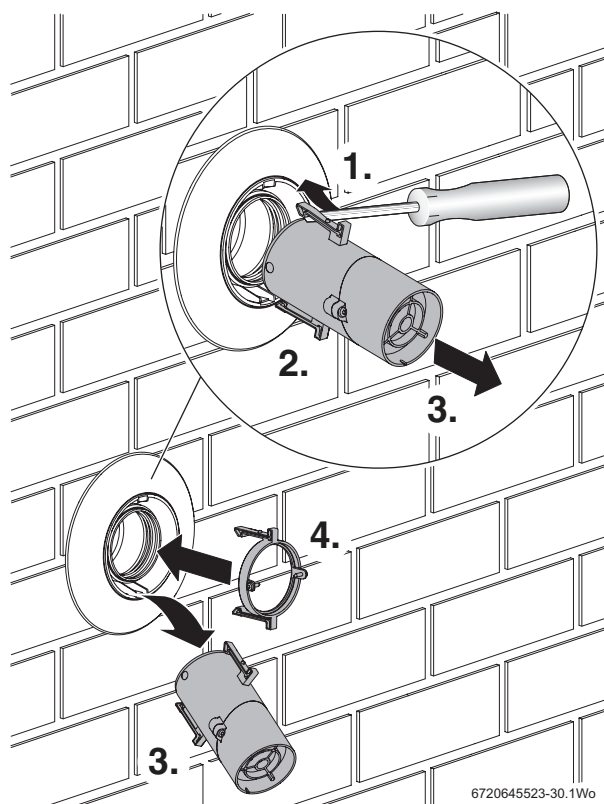

Fig. 41 Modifying the non telescopic flue

7 INSTALLATION

7.1 PLUME MANAGEMENT INSTALLATION - STANDARD



To ease assembly of the flue components, lightly grease the seals with the solvent-free grease supplied. Check all the seals are properly seated in the grooves provided and are in good condition. All flue joints must be sealed to prevent leakage of condensate and flue products.



NOTE: PLUME MANAGEMENT

▶ All plume management sections must rise away from the terminal by a minimum of 173mm per metre (10°) to allow the condensate to drain back to the boiler.

FITTING STANDARD PLUME MANAGEMENT SYSTEM:

Refer to figure 43 for terminal bend installation.

1. Remove and retain the screws and discard the terminal end.
2. Fit the new 90° bend to the terminal outlet and secure with the screws removed previously.
3. Mark the position for the wall clamp so that it coincides with the extension tube just below the top fitting (Refer to figure 44 point 2). Drill a hole to suit the wall plug and fit the wall plug.
4. Screw the clamp into the wall plug to the distance shown in figure 43.

Refer to figure 44 plume management installation.

1. Push the extension tube fully into the 90° bend, then withdraw the tube by approximately 10mm to allow for expansion.
2. Secure the extension to the wall with the clamp and screws provided.
3. Push the plume terminal fully into the extension tube.
4. Rotate the plume terminal to the required direction.
5. Secure the plume terminal to the extension with the self-tapping screw provided.

NOTICE:
Fit a flue damper into the plume management for 18/25 wall mounted Danesmoor boiler only.

Fit the damper (1) as shown in the figure opposite, ensuring the correct orientation of the damper. The rubber seal is inserted into the terminal end.

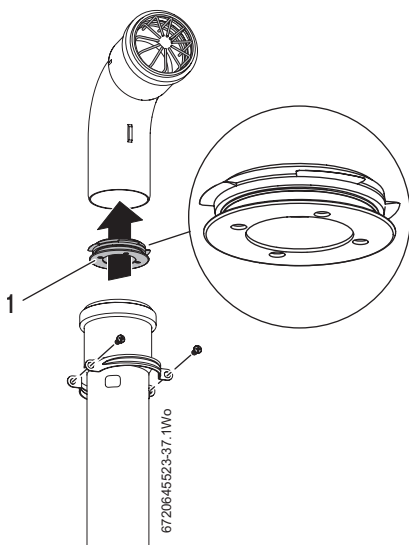

Fig. 42 Flue damper

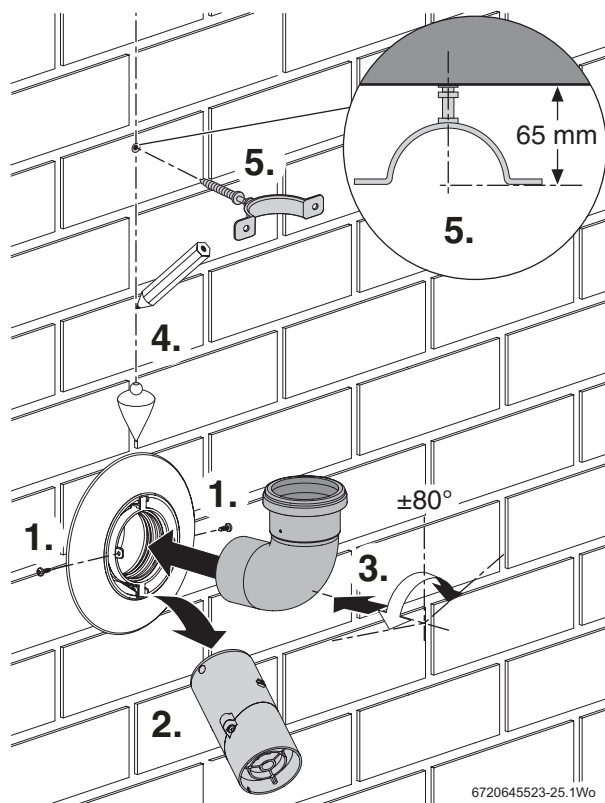

Fig. 43 Terminal bend installation

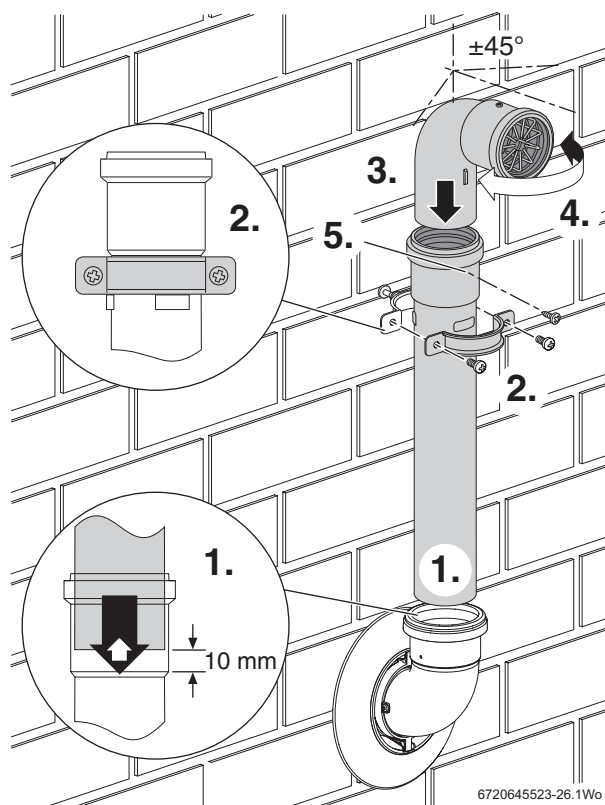

Fig. 44 Plume management installation

7.2 PLUME MANAGEMENT INSTALLATION - EXTERNAL BOILERS



NOTE: Camray 12/18 external boiler.

- ▶ Plume management installation is not available for this boiler.

SELECTING THE PLUME MANAGEMENT LENGTH



NOTE: Flue length:

- ▶ The flue length of all the external boilers using this plume management application will be in the range of 160 to 2000mm.

Refer to section 6.3 for information concerning:

- ▶ the flue damper installation
- ▶ the plume management system length
- ▶ the number of bends that can be employed in the plume management system.

FITTING THE TERMINAL ELBOW

Once the terminal elbow is fitted to the boiler, plume management assembly is as detailed in section 7.1 “Plume Management installation - Standard”

1. Remove and retain the screws that secure the terminal end into the flue.
2. Discard the terminal end.
3. Fit the terminal elbow into the flue but do not secure with the screws until the plume management system has been assembled.

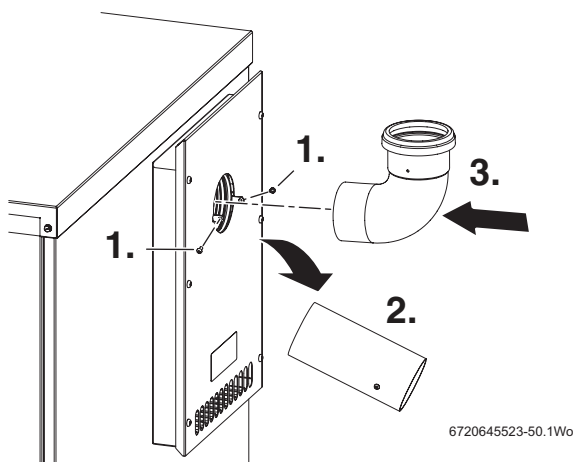

Fig. 45 Fitting the terminal bend

1. Refer to section 7.1 and assemble the plume management system.
 2. Once the plume management system is in place and secured to the wall, secure the terminal bend with the screws remove earlier.
- ▶ The terminal end can be positioned up to 45° either side of the central position, for plume re-direction.
 - ▶ Adjust the plume management terminal end into the desired position and secure with the screws provided.

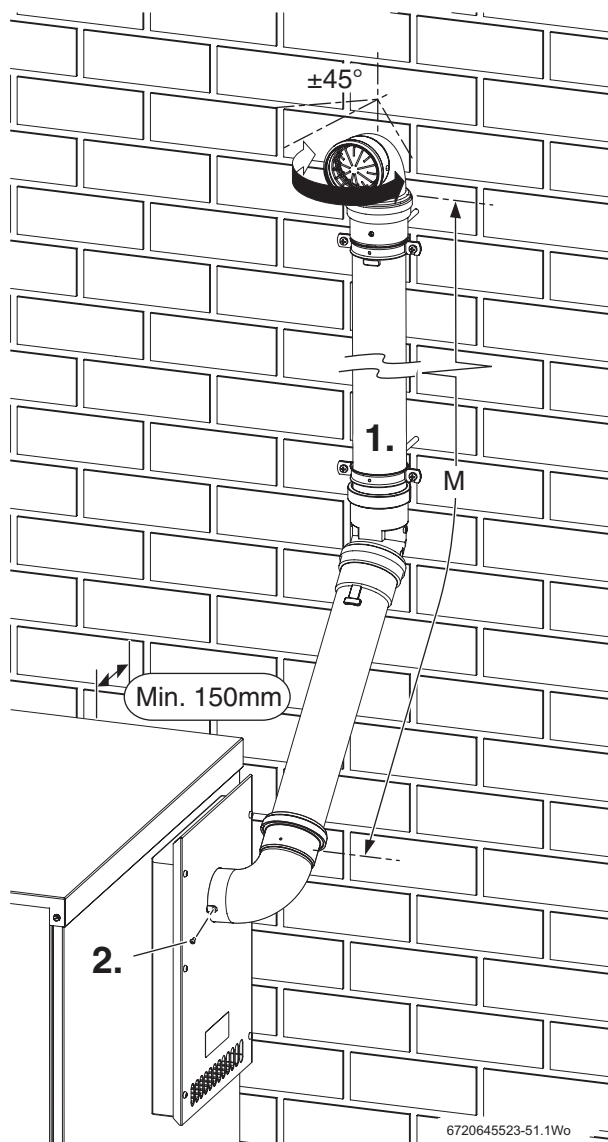

Fig. 46 Plume management detail

7.3 PLUME MANAGEMENT INSTALLATION - EXTENDED



To ease assembly of the flue components, lightly grease the seals with the solvent-free grease supplied.

Check all the seals are properly seated in the grooves provided and are in good condition.

All flue joints must be sealed to prevent leakage of condensate and flue products.



NOTE: PLUME MANAGEMENT

► All plume management sections must rise away from the terminal by a minimum of 173mm per metre (10°) to allow the condensate to drain back to the boiler.

FITTING THE EXTENDED PLUME MANAGEMENT:

1. Refer to figure 43 , remove and retain the screws securing the terminal end and discard the terminal end.
 2. Fit the 90° bend to the terminal outlet and secure with the screws retained earlier.
 3. If required, rotate the 90° bend for angled fluing.
- Refer to figure 47 and assemble the plume extensions.
1. Mark the position for the wall clamp that coincides with the extension tube, as shown. Drill a suitable hole and fit the wall plug. Screw the clamp into the wall plug as shown.
 2. Push the extension tube fully into the 90° bend, then withdraw the tube by approximately 10mm to allow for expansion.
 3. Secure the extension to the wall with the clamp and screws provided.
 4. Mount the other extension tubes as before and secure to the wall
 5. Push the plume terminal fully into the extension tube.

6. Rotate the plume terminal to the required direction and secure the terminal to the extension with the self-tapping screw provided.

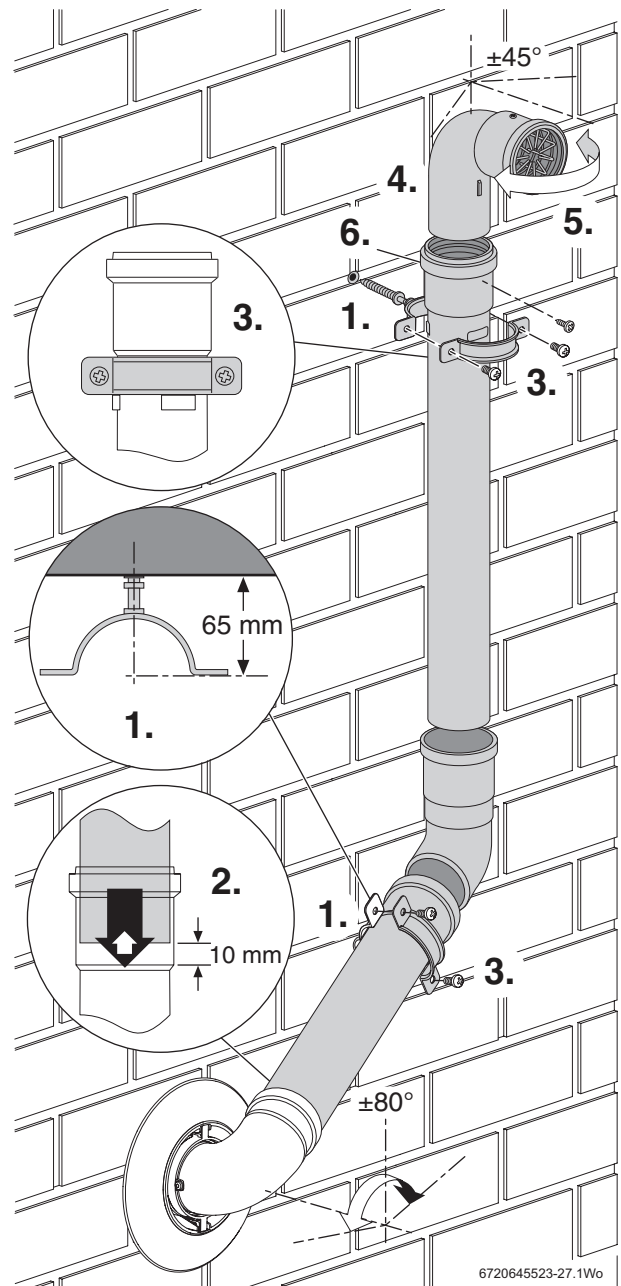

Fig. 47 Plume extensions

7.4 REDIRECTING THE FLUE DISCHARGE



The plume terminal can be adjusted to redirect the flue discharge.



NOTE: FLUE DISCHARGE

► The plume terminal position must follow those stated in figure 31. When redirecting the flue discharge the terminal must be at least 1500mm from and angle at least 45° away from any opening in the direction of the discharge, as shown. This is to prevent combustion products from entering the building.

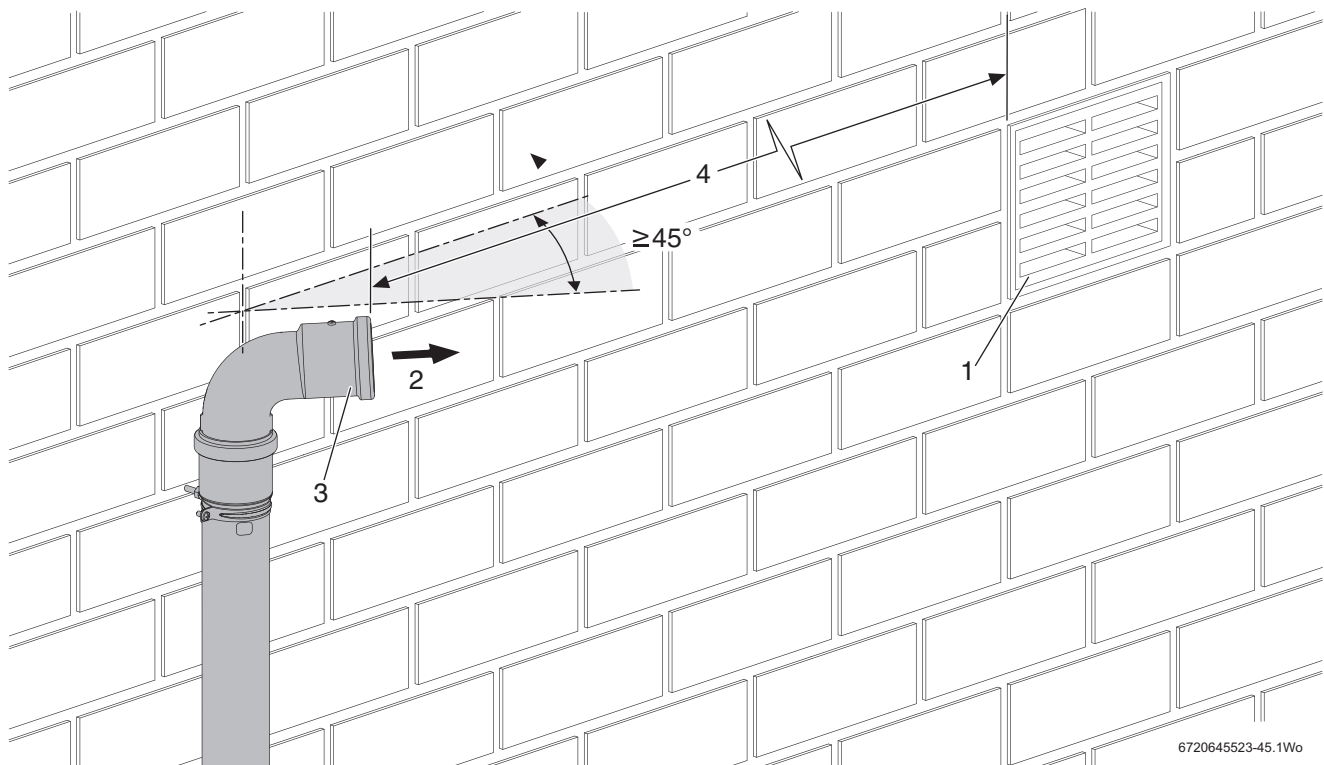

6720645523-45.1Wo

Fig. 48 Plume direction conditions

1	Opening in the building i.e. air brick, window.
2	Direction of flue products, the angle of the terminal elbow must be more than 45° from the wall or structure
3	Plume terminal
4	At least 1500mm from any opening in the building

Table 25 Key to figure 48

7.5 EXTENDED PLUME MANAGEMENT INSTALLATION FOR A BALCONY OR OVERHANG

i To ease assembly of the flue components, lightly grease the seals with the solvent-free grease supplied. Check all the seals are properly seated in the grooves provided and are in good condition. All flue joints must be sealed to prevent leakage of condensate and flue products.

1. Refer to figure 43 and remove and retain the screws and terminal end.
2. Fit the 90° bend to the terminal outlet and secure with the screws removed earlier.
3. If required, rotate the 90° bend for angled fluing.

i Flue dampers must be fitted to the Greenstar Danesmoor 18/25 wall hung boiler only regardless of flue or plume management length

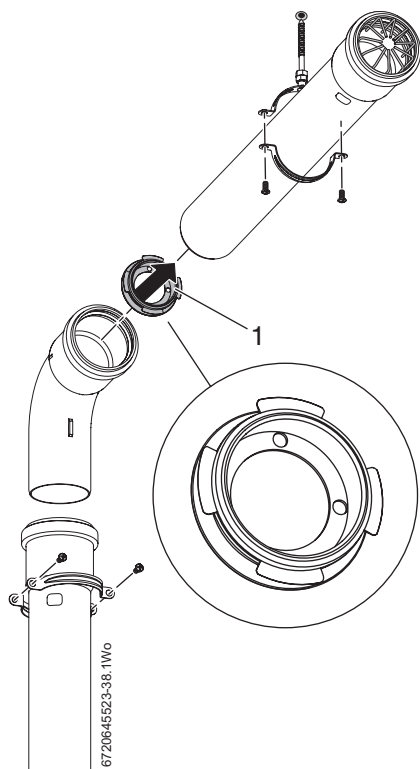

NOTICE: Fit a flue damper into the plume management for 18/25 wall mounted Danesmoor boiler only.

Fit the damper (1) as shown in figure 49, ensuring the correct orientation of the damper. The rubber seal is inserted into the extension tube. Then assemble the plume management system as shown in figure 50.

Fig. 49 Flue damper

1. Refer to figure 50 and mark the position for the wall clamp that coincides with the extension tube just below the top fitting. Drill a suitable hole and fit the wall plug. Screw the clamp into the wall plug as shown.
 2. Push the extension tube fully into the terminal bend, then withdraw the tube by approximately 10mm to allow for expansion.
 3. Secure the extension to the wall with the clamp and screws provided.
- Mount the other extension tubes as before and secure to the wall.

i Ensure that the plume outlet, projects at least 100mm past the balcony/overhang.

4. Remove the screw from the plume terminal and remove the grill and sleeve.
5. Drill a hole through the end of the extension end and secure the grill and sleeve in place.

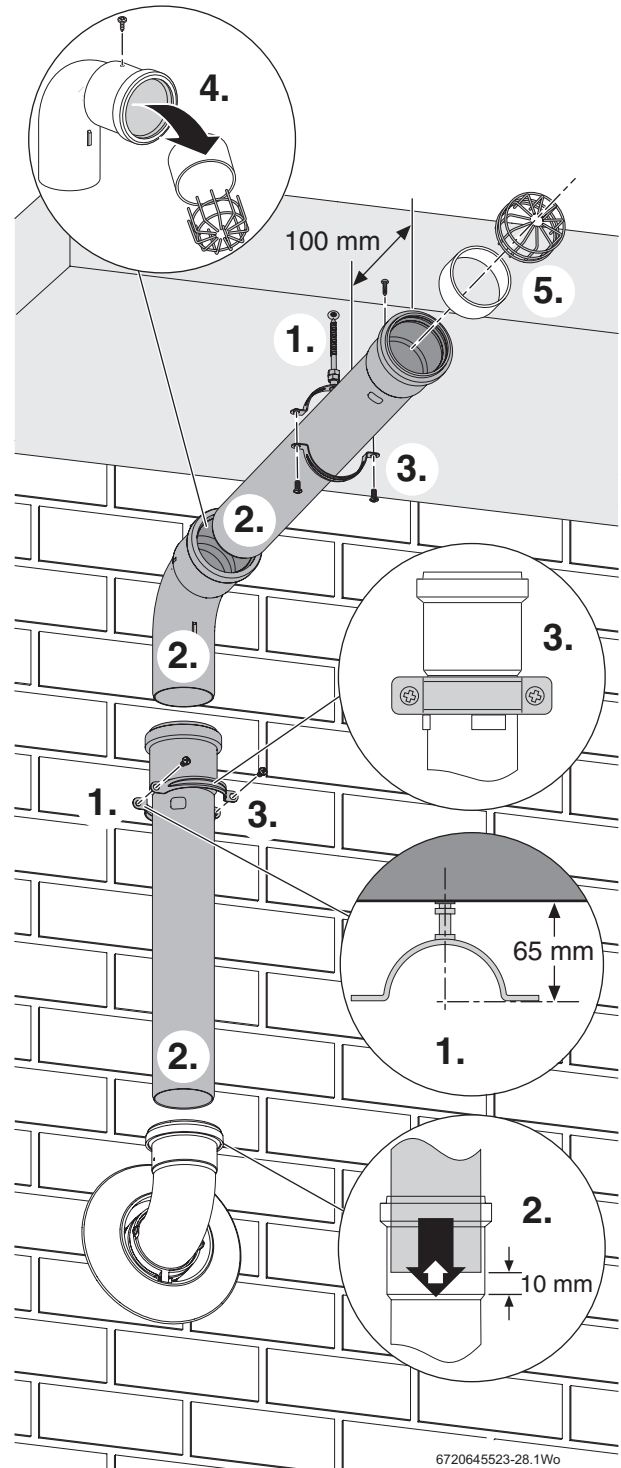

Fig. 50 Under balcony installation

WORCESTER, BOSCH GROUP:

TECHNICAL SUPPORT: 0844 8923366

APPOINTMENTS: 0844 8923000

SPARES: 01905 752571

LITERATURE: 0844 8929800

TRAINING: 01905 752526

SALES: 01905 752640

Worcester, Bosch Group
Cotswold Way, Warndon, Worcester WR4 9SW.
Tel. 0844 892 9900

Worcester, Bosch Group is a brand name of Bosch Thermotechnology Ltd.

worcester-bosch.co.uk

6 720 645 523b (2010/12)



WORCESTER
Bosch Group