

Code:

BK1

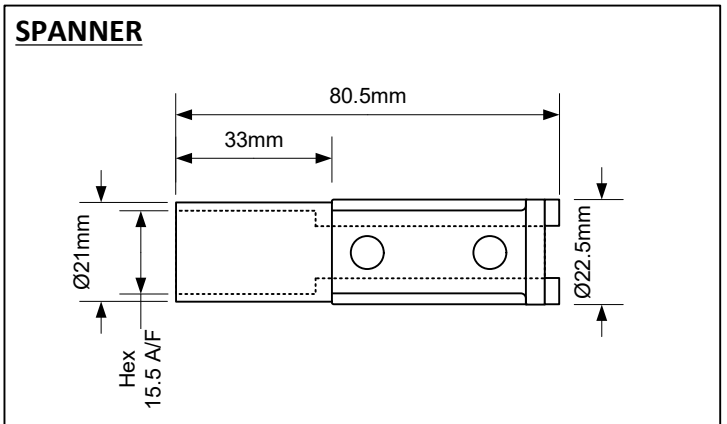
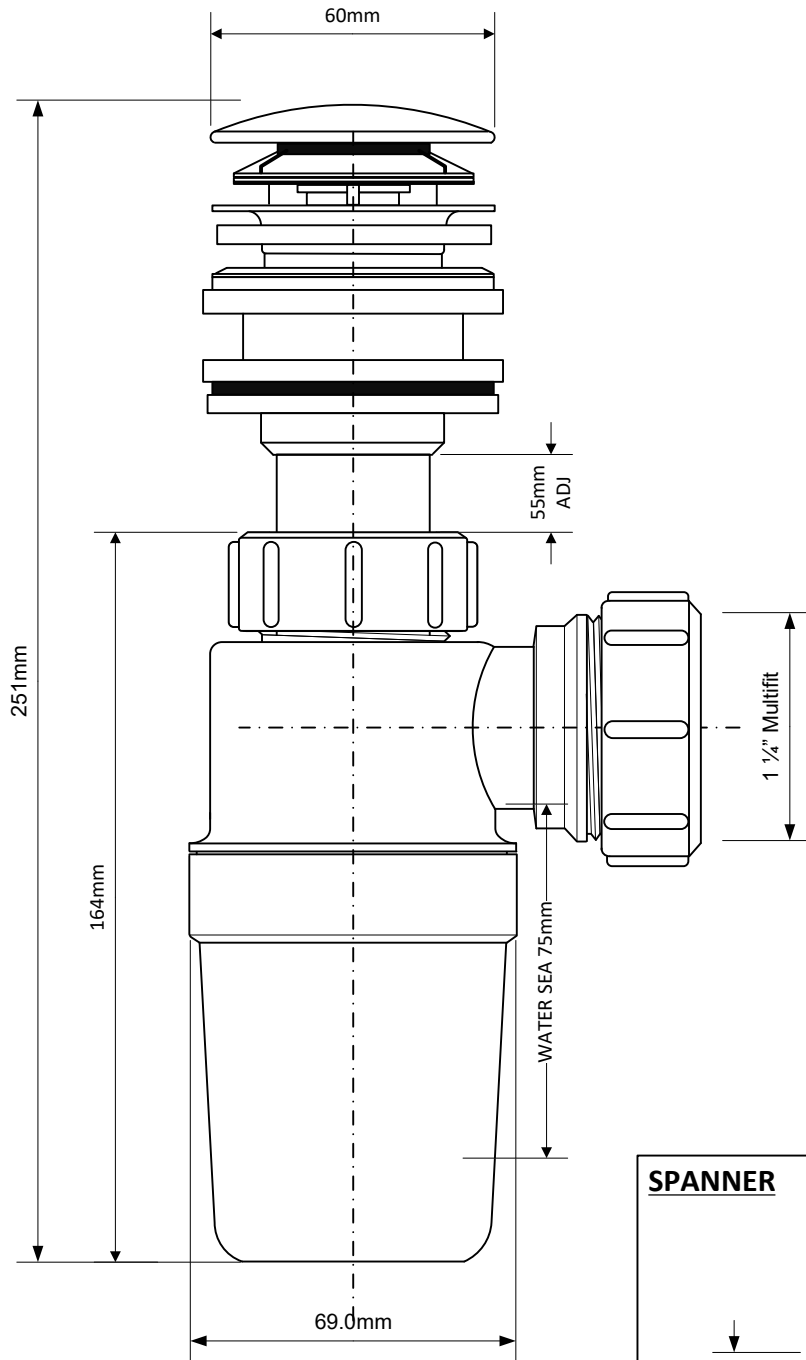

©  
McALPINE

Drawing verified  
correct as of:

DRAWN BY

TC

REVISED

SCALE

1: 1.6

FILENAME

BK1.VSDX

DATE

05.06.21

**Code:**

**BK1**

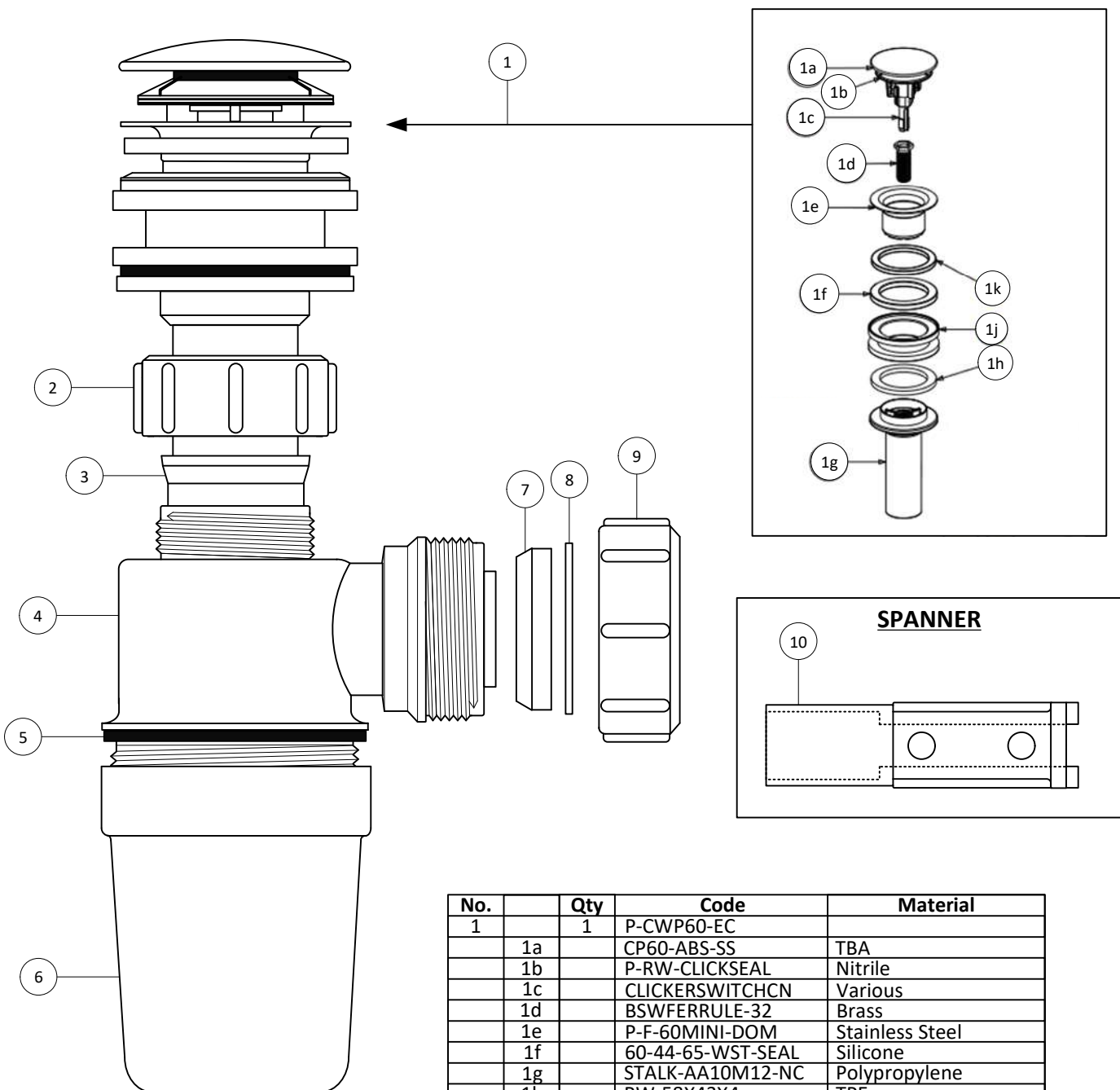

No.	Qty	Code	Material
1	1	P-CWP60-EC	
1a		CP60-ABS-SS	TBA
1b		P-RW-CLICKSEAL	Nitrile
1c		CLICKERSWITCHCN	Various
1d		BSWFERRULE-32	Brass
1e		P-F-60MINI-DOM	Stainless Steel
1f		60-44-65-WST-SEAL	Silicone
1g		STALK-AA10M12-NC	Polypropylene
1h		RW-58X43X4	TPE
1j		CWP60SPACER	Polypropylene
1k		P-SPW-60MM	Polyethylene
2	1	S8B	Polypropylene
3	1	AA10TUBE-NEW	TPE
4	1	AA10TOP-NEW	Polypropylene
5	1	P-RW-NEWBOTTLE	Nitrile
6	1	AA10BOTTOM-NEW	Polypropylene
7	1	RWM1	TPE
8	1	PWM1	Polypropylene
9	1	S8M	Polypropylene
10	1	SPANNER-BATHOF	A.B.S.



McALPINE

Drawing verified  
correct as of:

DRAWN BY

TC

REVISED

SCALE

1: 1.6

FILENAME

BK1.VSDX

DATE

05.06.21