

# **CG-900L-SQ & CG-900-XXL**

---

## **Condensing Unit & ASHP Guard Installation Instructions**



Pump House  
Glaisdale Drive East, Nottingham, NG8 4LY  
Tel ~ 0115 900 5858 Fax ~ 0115 929 4468

Email ~ [sales@pumphousepumps.com](mailto:sales@pumphousepumps.com) Website ~ [www.pumphousepumps.com](http://www.pumphousepumps.com)



# Installation Instructions

## GUARD STRUCTURE COMPONENTS

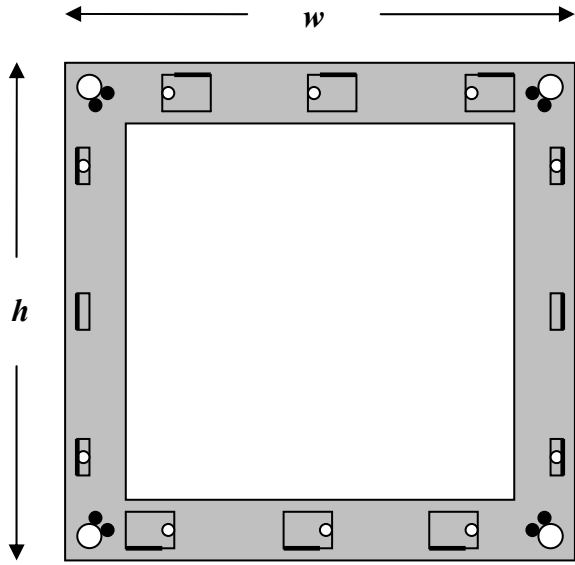

**A - Wall Frame x 2**

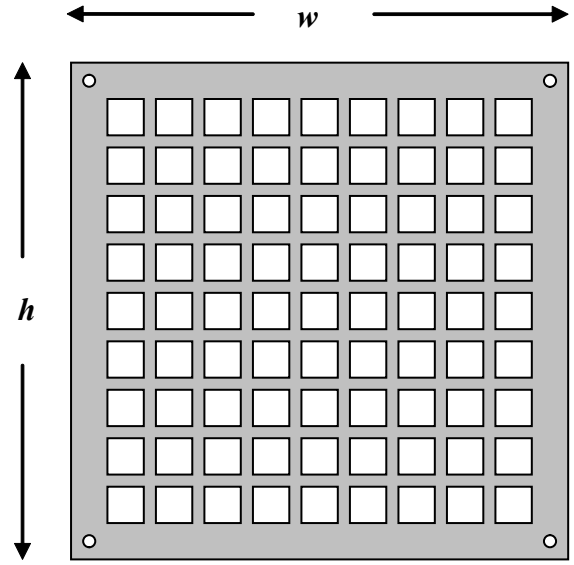

**E - Front Panel x 2**

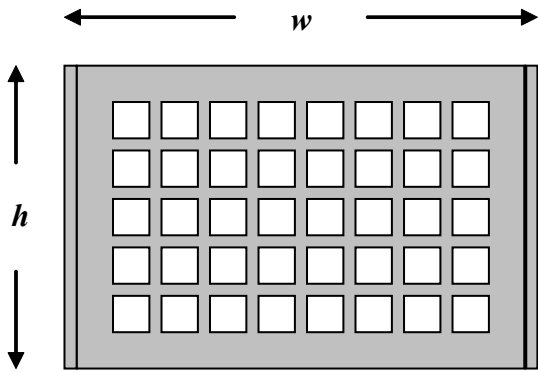

**C - Top Panel x 1**

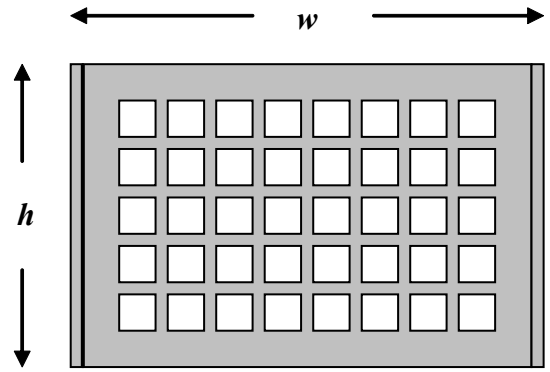

**D - Side Panel x 4**

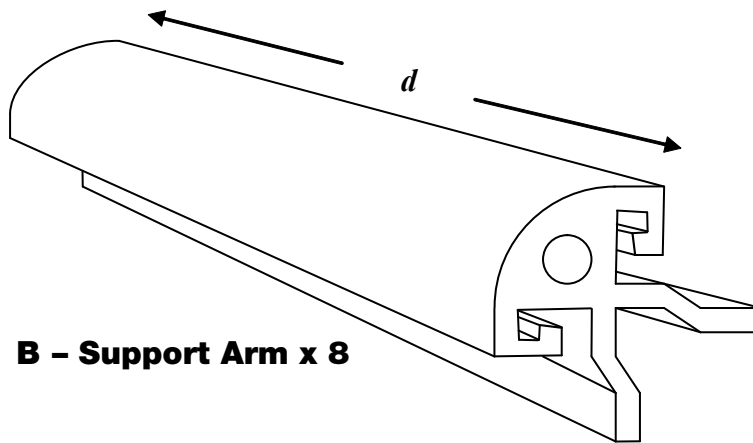

**B - Support Arm x 8**

# Installation instructions

## FIXINGS



**F - M8 x 25mm Allen-Headed Bolt x 16**



**G - Spring Washer x 8**

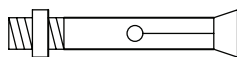

**H - Wall Anchor Bolt x 8**

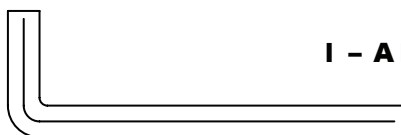

**I - Allen Key x 1**

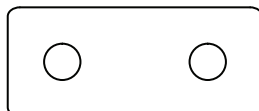

**J - Front Support Brackets x 2**

## COMPONENTS

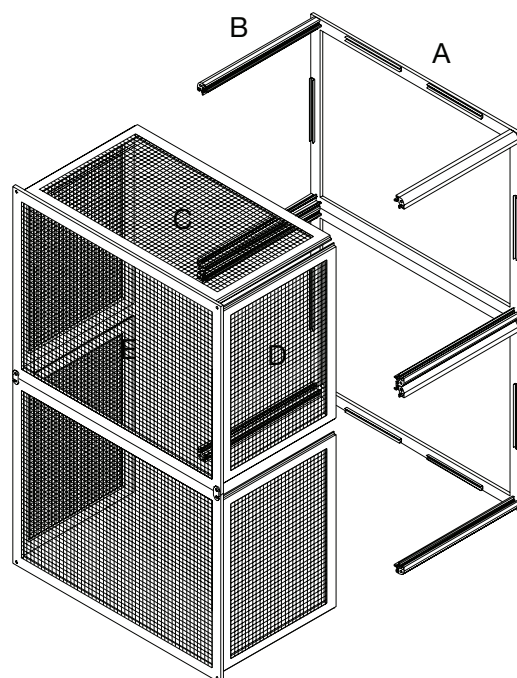

Please Note:

The components are supplied with standard, low-wall mounting models. Additional base panels (similar to the top panel) are available; these may be desired for high-wall mounted installations. Additional back panels (similar to the front panel) are available; these will be required for floor-standing installations.

LIST OF COMPONENTS			Dimensions (mm)					
			CG-900L-SQ			CG-900-XXL		
Item	Qty	Description	<i>h</i>	<i>w</i>	<i>d</i>	<i>h</i>	<i>w</i>	<i>d</i>
A	2	Wall Frame	725	1450		900	1450	
B	8	Support Arm			900			900
C	1	Top Panel		1420	900		1420	900
D	4	Side Panel	695		900	870		900
E	2	Front Panel	725	1450		900	1450	
F	16	M8 x 20mm Allen-Headed Bolt						
G	8	Spring Washer						
H	8	Wall Anchor Bolt						
I	1	Allen Key						
J	2	Front Panel Support Bracket						

# Installation Instructions

## INSTALLATION GUIDE

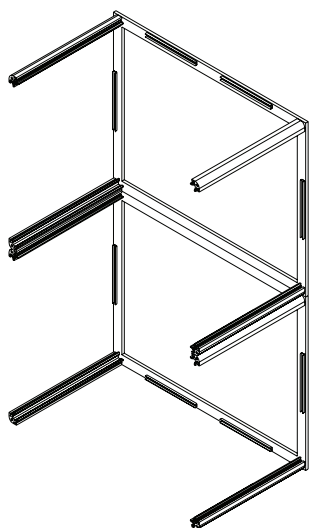

1. Fit arms to wall frame and then fix to the wall

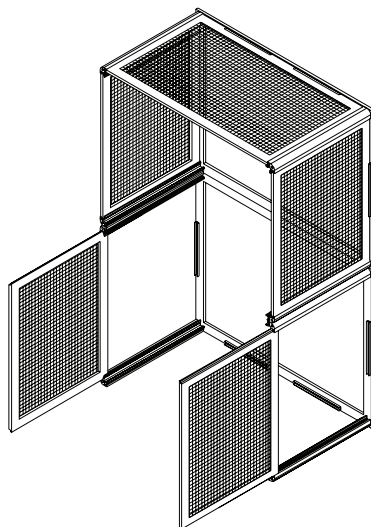

2. Slide in top and side panels

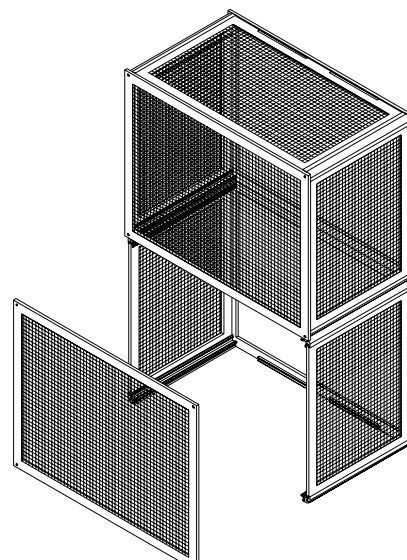

3. Fix the front panels and secure with front panel supports

	Height(mm)	Width(mm)	Depth(mm)
CG-900L-SQ	1450	1370	900
CG-900-XXL	1800	1370	900

Guard Size	BASE-PANEL part code	FRONT/BACK-PANEL part code
CG-900L-SQ	CG-BP900L	CG-FP-900L-SQ
CG-900-XXL	CG-BP900L	CG-FP-XXL

### ADDITIONAL PANELS:

To add a base panel for high, wall-mounted guards, order a BASE-PANEL.

To add a back panel for free-standing, floor-mounted guards, order a FRONT/BACK-PANEL (supplied as two pieces).

## GUIDANCE ON INSTALLATION

1. The purpose of this product is to protect the equipment unit against reasonable levels of vandalism and accidental damage.
2. Whilst this product is sufficiently robust for its purpose, it is not designed to be load-bearing, and should not be used to support excessively heavy items.
3. Where possible, this product should be installed at the same time as the condensing unit.
4. Where a guard is fitted retrospectively, the location of supply services may hinder installation, and it is expected that parts of the guard structure may have to be removed in order to facilitate the installation. In these cases, care must be taken to ensure that the rigidity of the structure is not compromised.

# Installation Instructions

## STEP-BY-STEP INSTALLATION INSTRUCTIONS

1. Using four of the Allen-headed bolts (F) connect the 4 support arms (B) to one of the wall frames (A). The wall frame has two small protrusions in each of its four corners to help you locate the arms in the correct position.
2. Place the wall frame in the required location and mark the wall for the fixing holes. The wall frame offers 10 possible positions for the wall fixings and 4 fixings are provided (H); ideally you should use the fixing holes towards the corners of the frame.
3. Drill holes in the wall in the locations marked, and insert the wall anchor bolts (H) into the holes drilled.
4. Hook the wall frame (A) onto the anchor bolts (H) and tighten the nuts to secure.
5. Repeat steps 1 to 4 for the other wall frame and the other 4 support arms, ensuring that the second wall frame is positioned directly above, and adjacent to, the wall frame.
6. Slide the top panel (C) and side panels (D) into the grooves on the support arms (B). (Slots are provided in the wall frame (A) into which the top and side panels should locate.)
7. Fit the front panels (E) to the support arms (B) using the remaining four sets of Allen-headed bolts (F), the spring washers (G) and the two front panel support brackets (J) (these brackets should straddle the joint between the two front panels to add rigidity to the guard)

## HIGH-WALL MOUNTING UNITS

If you have purchased an additional base panel for a high-wall mounted installation, this should be installed between steps 7 and 8.

It is possible to assemble the complete guard at ground level and then simply hook it onto the pre-inserted wall fixings. This facility can be beneficial in circumstances where high wall assembly is difficult.

Pump House supply a range of mounting brackets suitable for most brands of a/c condensing units and air source heat pumps.

## FLOOR-STANDING UNITS

If you have purchased additional back panels for a free-standing / floor-mounting installation, these should be connected to the support arms (B) at Step 1, instead of the wall frames. The extra back panels are supplied with four brackets which should be connected to the front and back panels, at each of the four bottom corners of the guard. These brackets can then be used for securing the guard to the floor.

## MAINTENANCE

These guards are designed to allow quick and easy access for maintenance of the condensing unit. Simply reverse Steps 6 and 5 to obtain complete access to the condensing unit.