

# SALUS<sup>®</sup> CONTROLS

Energy Saving A Rated Circulating Pump

**Models: MP100A, MP200A & MP280A**

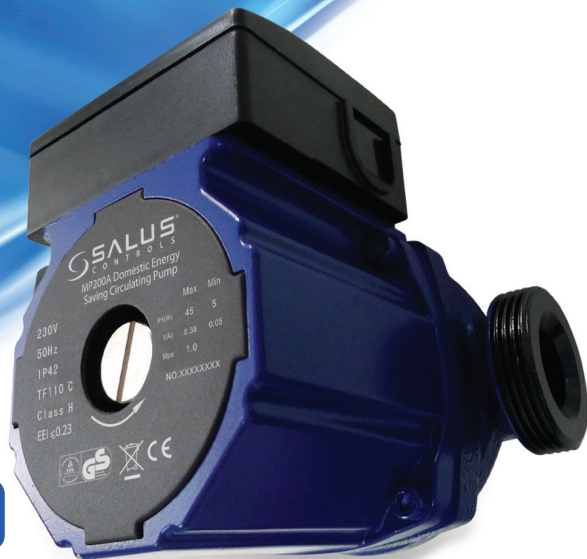

OPERATION MANUAL

## Product compliance & safety information

These instructions are applicable to the SALUS Controls model stated on the front cover of this manual only, and must not be used with any other make or model.

This accessory must be fitted by a Competent person, and installation must comply with the guidance provided in the current IEE Wiring Regulations and any relevant Building Regulations. Failure to comply with the requirements of these publications could lead to prosecution.



**Always isolate the AC Mains supply before installing or working on any components that require 230 VAC 50Hz supply.**

Please leave these instructions with the end user where they should be kept in a safe place for future reference.

# Contents of the box



1x Energy Saving A Rated Circulating Pump



1x Operation Manual



Seals



Connector



Plug



Grommit

## Notes

01. Read the installation manual carefully before installation and use.
02. SALUS will not be liable for any personal injury, pump damage and other property damage due to failure to comply with contents specified in safety warning signs.
03. The installers and operators must comply with all relevant local safety regulations.
04. The user must confirm that only qualified personnel with professional certification and proficiency of this manual is allowed to install and maintain this product.
05. The pump must not be installed in a place that is damp or may be splashed by water.
06. For convenient access of maintenance, a shut-off valve shall be installed on each side of the pump.
07. The power supply of the pump shall be cut off before installation and maintenance.
08. For domestic hot water, copper or stainless steel pump body shall be used.
09. Heat supply pipelines shall not be frequently filled with non-softened water so as to avoid increasing calcium in the circulating water inside the pipeline, which may thus block the impeller.
10. Do not start the pump without liquid.
11. Not suitable for drinking water.
12. The liquid may be high temperature and high-pressure; therefore, the liquid in the system must be completely drained or the shut-off valves on both sides, closed before moving and dismantling the pump to prevent burning.
13. If removing the vent plug, high temperature and high-pressure liquid will be overflow. Therefore, it is necessary to guarantee that the outflow liquid will not cause personal injury or damage other parts.
14. Ventilation must be ensured in summer or high ambient temperature period to avoid condensation that may cause electrical malfunctions.
15. In winter, the pump system does not work or when the ambient temperature drops below 0°C, liquid in the system shall be completely drained so as to avoid frost cracking of pump body.
16. If the pump is left unused for a long time, please close the pipe valve in the inlet and outlet of the pump and cut off the power supply.

### 04 Energy Saving A Rated Circulating Pump

## Notes continued

17. If the flexible cord of cable is damaged, it must be replaced by a qualified person.
18. Please close the valve at the inlet of the pump and cut off power of the pump immediately if overheating and abnormality of motor is detected, and contact SALUS technical helpline immediately.
19. If trouble cannot be addressed according to the manual, please close the valves on the inlet and outlet of the pump immediately, cut off power supply and contact your vendor or service center immediately.
20. This product shall be put in a place out of reach of children. After installation, take an isolation measures to avoid access of children.
21. This product shall be stored in a dry, well ventilated and cool place under room temperature.

**SALUS Technical Helpline +44 (0) 1226 323961 Email: [tech@salus-tech.com](mailto:tech@salus-tech.com)**



### **Warning**

Before installation, you must carefully read the installation and operation manual. The installation and use of the equipment must comply with local regulation and applicable operation standards.



### **Warning**

Those who have weak physical strength, react slowly or lack experience and knowledge (including children) can use this motor pump only under the monitoring and direction of his/her safety personnel.

## 1. Signs



**Warning** - Failure to comply with this safety instruction may lead to personal injury and prosecution.



**Caution** - Failure to comply with this safety instruction may lead to pump malfunction or damage!



**Note** - Note or instruction for easy and safe operations.

## 2. General

### 2.1. SALUS MPA series circulation motor pump is mainly used in domestic heating and hot water system.

The product is most applicable to the following systems:

- stable and variable-flow heat supply system
- variable-temperature pipeline heat supply system
- heat supply system with night mode
- HVAC system
- industrial circulation system
- domestic heating and domestic water supply system

This pump is equipped with permanent-magnet motor and differential pressure controller, capable of automatically & continuously adjusting motor performance to meet the actual needs of system.

This pump is equipped with control panel on the front for easy operation by users.

### 2.2. Advantages

Easy installation and start-up

- Provided with self-adaptive mode AUTO

(Initial setting). In most cases, the motor pump needs no adjustment and can be readily started and automatically adjusted to meet the actual needs of the systems.

#### High-degree comfort

- Low operational noise of motor pump and whole system.

#### Low energy consumption

- Compared with traditional circulation motor pumps, it has lower energy consumption. SALUS MPA series circulation motor pump is attached with Europe Energy Label Class A marking, and the minimum energy consumption can reach up to 5W.

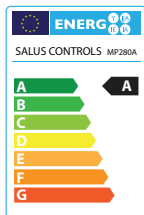

## 3. Operating Conditions

### 3.1 Ambient Temperature

Ambient temperature: 0 °C ~ +40 °C

### 3.2 Relative humidity (RH) :

Max. humidity: 95%

### 3.3 Medium (liquid delivery) temperature

Liquid delivery temperature: +2 °C ~ 110 °C

To avoid condensation in control box and the stator, the temperature of liquid pumped by the motor pump must be always higher than ambient temperature.

### 3.4 System Pressure

Maximum pressure 1.0Mpa(10bar).

### 3.5 Degree of Protection

IP42

### 3.6 Inlet Pressure

Liquid Temperature	<85°C	90°C	110°C
Inlet Pressure	0.05bar	0.28bar	1bar
	0.5m head	2.8m head	10m head

### 3.7.Pumping Liquid

The pumping liquid includes thin, clean, non-corrosive and non-explosive liquid which shall not contain any solid particles, fiber or mineral oil, and the pump must definitely not be used to pump inflammable liquid such as rapeseed oil and gasoline. If the pump is used in a place with relatively high viscosity, the pump has lower performance. So when choosing a pump, the viscosity of liquid must be taken into account.

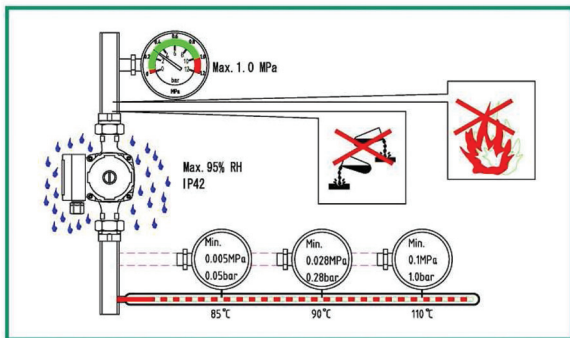

## 4. Installation

### 4.1 Installation

- When installing SALUS MPA series circulation pump, the arrow on motor pump case indicates the flow direction of liquid through the pump.
- When installing the motor pump in the pipeline, two supplied gaskets must be installed at the inlet and outlet.
- During the installation, the shaft of motor pump must be horizontal.

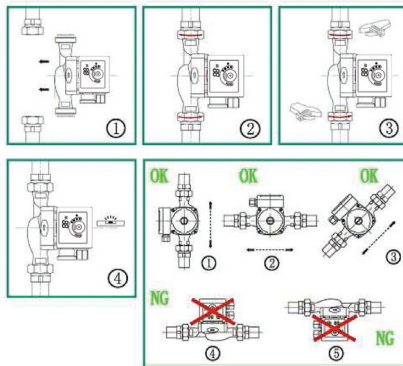



## Position of Junction Box

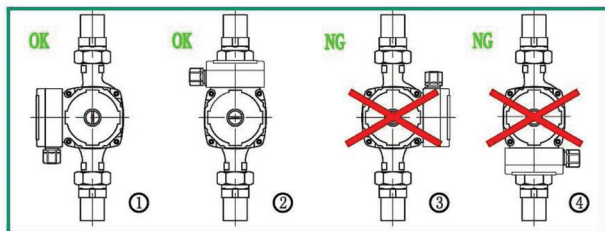

## Changing Position of Junction Box

The junction box can be rotated in a step of 90°

The procedures for changing the position of junction box are as follows:

1. Close the valves at the inlet and outlet and release the pressure.
2. Unscrew and remove the four socket head screws that fasten the pump body.
3. Rotate the motor to the expected position and align the four holes.
4. Install the four socket head screws again and fasten them clockwise.
5. Open the valves at the inlet and outlet.

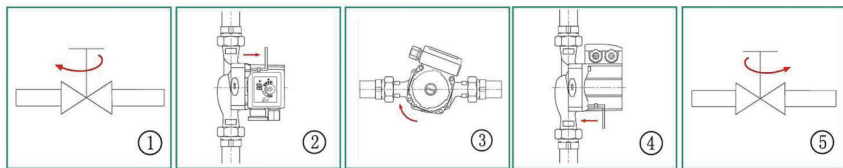



### Warning

Pumping liquid may be high-temperature and high-pressure; therefore, the liquid in the system must be completely drained or the valves on both sides of motor pump must be closed before removing the socket head screws.

## Thermal Insulation of Motor Pump Body

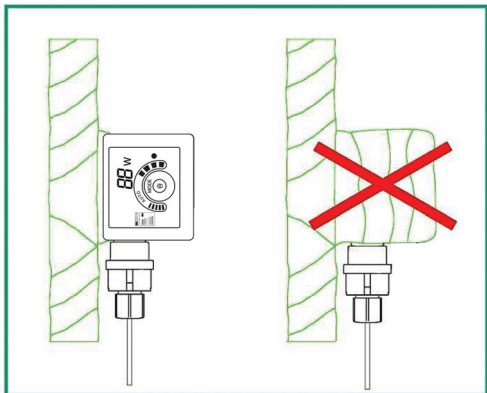

Limiting the heat loss of motor pump body and pipeline. Motor pump body and pipeline should be thermally insulated to reduce their heat loss.



Do not isolate or cover the junction box and control panel.

## 5. Electrical Connection

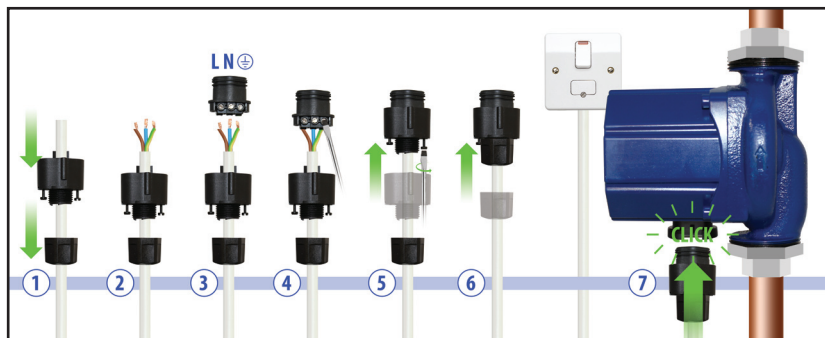

### Warning

The motor pump must be earthed. 

The motor pump must be connected to an external power switch, and the minimum space between all the electrodes is 3mm.

- SALUS MPA series circulation motor pump needs no protection from external motor. Check if the supply voltage and frequency are the same as parameters indicated on the nameplate of the motor pump.
- Connect the power supply to the plug supplied.
- After the power is supplied, the indicator lamp on the control panel is ON.

## 6.1 Controls on Control Panel

Position	Descriptions
1	Monitor that displays the actual power consumption of motor pump in Watt.
2	Indication area of seven modes.
3	Button for setting operation modes of the motor pump.

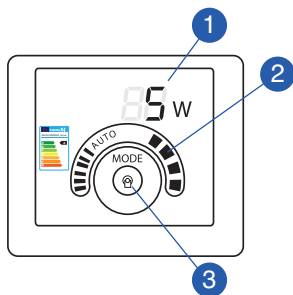

## 6.2 Indication lamp area of power consumption of motor pump

After the power is connected, the monitor in Position 2 works. During operation, the indicated value is in Watt, showing the actual power consumption of the motor pump.

When the motor pump fails to work, the monitor indicates :  
If malfunction is detected, the power supply must be cut off before troubleshooting. After the trouble is addressed, re-connect the power and start the motor pump.

Fault Code	Description
E0	Over-voltage protection
E1	Under-voltage protection
E2	Over-current protection
E3	Under-load protection
E2↔E4	Open-phase protection

## 6.3 Indication Lamp Area of Motor Pump Setting

SALUS MPA - series circulation motor pump has eight settings which can be chosen with the button. The motor pump settings are indicated with seven different indication areas.

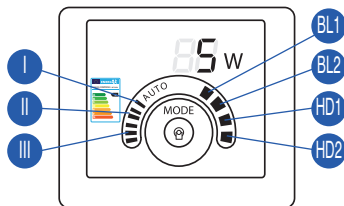

Button Times	Indication Lamp Area	Descriptions
0	AUTO (Initial setting)	Self-adaptive (AUTO)
1	BL1	Lowest Proportional Pressure Curve
2	BL2	Highest Proportional Pressure Curve
3	HD1	Lowest Constant Pressure Curve
4	HD2	Highest Constant Pressure Curve
5	III	Constant Velocity Curve, Velocity III
6	II	Constant Velocity Curve, Velocity II
7	I	Constant Velocity Curve, Velocity I

## 6.4 Button for selecting motor pump settings

By pressing the button once at 2 seconds interval, the motor pump setting mode will change once. A cycle is constituted of every eight presses on the button. For details, please refer to Section 6.3.

# 7. Pump Setting

## 7.1. Pump Setting Based on System Type

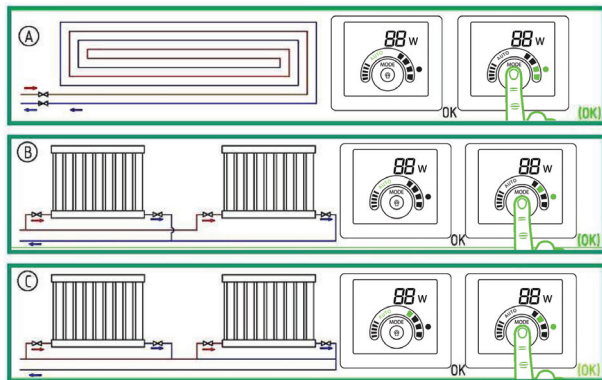

Initial setting= AUTO (Self-adaptive mode)

Recommended and available pump setting

Position	System Type	Motor Pump Setting	
		Recommended	Options
A	Floor heating system	AUTO	HD1, HD2
B	Dual pipeline heating system	AUTO	BL2
C	Single pipeline heating system	BL1	BL2

- AUTO (Self Adaptive Mode) mode can adjust the performance of motor based on the actual heat demand of the system. As the performance is adjusted gradually, it is suggested, before changing motor pump setting, to maintain AUTO (Automatically Adaptive Mode) mode setting for at least one week.
- If you select to change back to AUTO (Self Adaptive Mode) mode, the SALUS MPA series motor pump can memorize its last setting in AUTO mode and continue adjusting the performance automatically.
- It may take several minutes or even hours to reach the optimum operation mode after motor pump setting is changed from the optimal setting (the “Recommended abovemention” to other optional setting. If the optimal setting of motor pump fails to enable each room to obtain desired heat distribution, then you should change the motor pump setting to other settings.
- Please refer to section 12.1 for the relations between pump setting and performance curve.

## 7.2 Control Pump

When the pump is working, the pump is controlled according to the principle of “Proportional Pressure Control (BL)” or “Constant Pressure Control (HD)”

In these two control modes, the pump performance and corresponding power consumption will be regulated according to the heat demand of the system.

### **Proportional Pressure Control**

In this control mode, the differential pressure of both ends of the pump will be controlled by the flow rate. In the Q/H Figure, proportional pressure curve is represented with BL1 and BL2. Please refer to Section 12.1

In these two control modes, the pump performance and corresponding power consumption will be regulated according to the heat demand of the system.

### **Constant Pressure Control**

In this control mode, the differential pressure of both ends of the pump remains constant and is irrelevant to the flow rate. In the Q/H Figure, constant pressure curve is a horizontal performance curve represented with HD1 and HD2. Please refer to Section 12.1.

## 8. Bypass valve system installed between the Inlet pipeline and return pipeline

### 8.1. Purposes of bypass valve

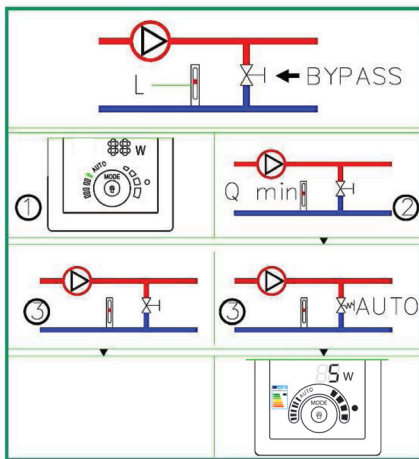

### Bypass valve

The purpose of bypass valve: when all the valves and/or temperature-sensing valves of heat radiator in the floor heating loop are closed, it can ensure that the heat from boiler can be distributed.

Elements in the system:

- bypass valve
- flow meter, position L.

When all valves are closed, the minimum flow rate must be guaranteed.

The setting of pump position depends on the type of bypass valve, i.e. manual bypass valve or temperature-sensing bypass valve.

### 8.2. Manually-operated Bypass Valve

In accordance with the following procedures:

1. When regulating bypass valve, the pump shall be in Setting I (Velocity I Mode). The minimum flow rate ( $Q_{min}$ ) of the system shall be always guaranteed. Please refer to bypass valve manual provided by the manufacturer.
2. After the regulating of bypass valve completes, set the pump in accordance with Section 12.1 of Pump Setting.



### 8.3. Automatic Bypass Valve (temperature-sensing type)

Follow the following procedures:

1. When regulating bypass valve, the pump shall be in Setting I (Velocity I Mode). The minimum flow rate ( $Q_{\min}$ ) of the system shall be always guaranteed. Please refer to bypass valve manual provided by the manufacturer.
2. After the regulating of bypass valve completes, set the pump to lowest or highest constant pressure mode. For the relations between pump setting and performance curve, please refer to Section 12.1 of Pump Setting and Pump Performance.

## 9. Start up

### 9.1. Before Start Up

Before starting the motor pump, ensure that the system is filled with liquid, air has been completely exhausted, and the inlet of motor pump must reach minimum inlet pressure. Please refer to Chapter 3.

### 9.2. Exhaust the Motor Pump

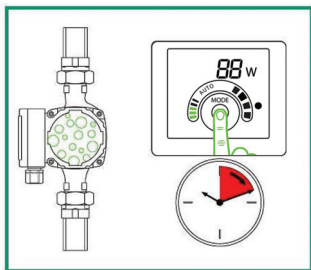

SALUS MPA series motor pump is equipped with self-venting function. Before the start up, it is not necessary to vent the air. Air in the motor pump may cause noise. After the motor pump is put into operation for several minutes, the noise will disappear. Based on the system scale and structure, set the SALUS MPA series motor pump to Velocity III for a short period of time and air in the pump can be quickly vented. After air is vented from the motor pump and noise disappear, set the motor pump in accordance with the manual. Please refer to Chapter 7.



Motor pump cannot run in idle speed without pumping liquid.

### 9.3. Vent the heating system

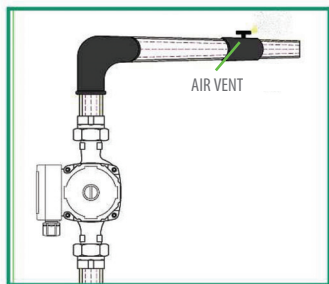

Please ensure the system and pump is correctly vented.

## 10. Motor Pump Setting and Performance

### 10.1. Relations between Pump Setting and Performance

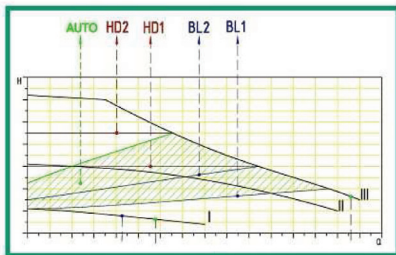
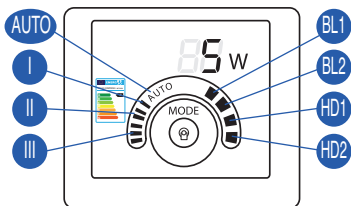

Setting	Pump Characteristics Curve	Functions
AUTO (Initial Setting)	Highest to Lowest Proportional Pressure Curve	AUTO function will automatically control the pump performance within the specified scope. Adjust pump performance based on system scale; adjust pump performance based on load variance within a period of time; Under the AUTO mode, the pump will be set to proportional pressure control;
BL1	Lowest Proportional Pressure Curve	The operating point of the pump will move up and down on the lowest proportional pressure curve based on the demand of system flow rate. When flow demand decreases, the pressure supply of pump drops; when flow demand increases, the pressure supply of pump rises.
BL2	Highest Proportional Pressure Curve	The operating point of the pump will move up and down on the highest proportional pressure curve based on the demand of system flow rate. When flow demand decreases, the pressure supply of pump drops; when flow demand increases, the pressure supply of pump rises.

Setting	Pump Characteristics Curve	Functions
HD1	Lowest Constant Pressure Curve	The operating point of the pump will move around the lowest constant pressure curve based on the demand of system flow rate. The supply pressure of pump remains constant and it is irrelevant with the flow rate.
HD2	Highest Constant Pressure Curve	The operating point of the pump will move around the highest constant pressure curve based on the demand of system flow rate. The supply pressure of pump remains constant and it is irrelevant with the flow rate.
III	Velocity III	It runs on the constant curve in a constant velocity. In the Velocity III mode, the pump is set to work on the highest curve under all working conditions. Setting the pump as Velocity III mode within short period of time can quickly vent the pump.
II	VelocityII	It runs on the constant curve in a constant velocity. In the Velocity II mode, the pump is set to work on the intermediate curve under all working conditions.
I	Velocity I	It runs on the constant curve in a constant velocity. In the Velocity I mode, the pump is set to work on the lowest curve under all working conditions.

# 11. Performance Curve

## 11.1. Guide on Performance Curve

Every setting of the motor pump has corresponding performance curve (Q/H curve). However AUTO (Self Adaptive Mode) mode covers just one performance scope. The area of PWM signal control performance curve (Q/H curve) is between motor pump velocity I-III. The input power curve (P1 curve) belongs to every Q/H curve. Power curve represents the power consumption of motor pump in given Q/H curve with Watt as the unit. P1 value corresponds to the readings taken from the monitor of motor pump.

## 11.2. Curve conditions

The followings are applicable to the performance curve specified in the SALUS MPA series manual:

- Test liquid: air-free water.
- Applicable density of curve  $\rho=983.2 \text{ kg/m}^3$ , and liquid temperature  $+60^\circ\text{C}$ .
- All curves represent averaged value, and shall not be used as guarantee curve.  
If a specific performance is needed, then separate measuring shall be conducted.
- Velocity I, II, III curves have all been marked.
- The applicable Kinetic viscosity of the curve  $\nu=0.474 \text{ mm}^2/\text{s}$  ( 0.474CcST )

### 11.4. SALUS MP100A Performance Curve

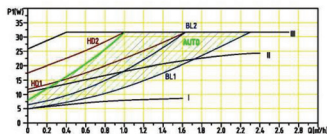
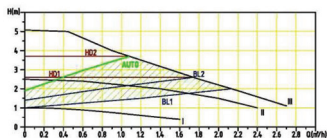

### 11.5. SALUS MP200/MP280A Performance Curve

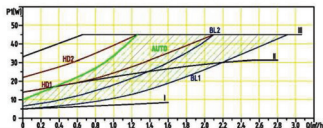
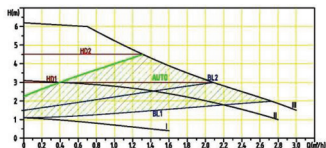

## 12. Features

### 12.1. Nameplate Instructions

No.	Descriptions	
1	Manufacturer Name	
2	Product Model	
3	Product No.	Digit 1 to digit 6 indicates manufacturing date
		Digit 7 to digit 10 indicates serial number
4	Power (Watt)	Minimum input power P1
		Maximum input power P1
5	Current (Amp)	Minimum current
		Maximum current
6	Maximum system load bearing (Mpa)	
7	Authentication mark	
8	Direction of rotation	
9	Temperature class	
10	Degree of protection	
11	Insulation class	
12	Energy Index	
13	Frequency (Hz)	
14	Voltage (v)	

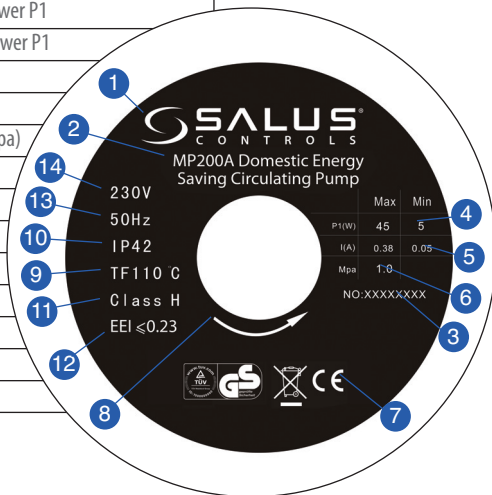

## 13.1 Technical Parameters

Power Supply Voltage	230V AC 50Hz	
Motor Protection	The pump needs no external protection	
Degree of Protection	IP42	
Insulation Class	H	
Relative Humidity (RH)	Max. 95%	
System Load Bearing	1.0 MPa	
Suction Port Pressure	Liquid Temperature	Minimum Inlet Pressure
	≤+85°C	0.005 MPa
	≤+90°C	0.028 MPa
	≤+110°C	0.100 MPa
EMC Standard	EN61000-6-1 and EN61000-6-3	
Sound Pressure Class	The sound pressure level of pump is lower than 43dB (A)	
Ambient Temperature	0~+40°C	
Temperature Grade	TF110	
Surface Temperature	The maximum surface temperature is not higher than +125°C	
Liquid Temperature	+2~+110°C	

## 13.1 Technical Parameters

To prevent condensation in the junction box and rotor, the temperature of pumping liquid of the motor pump must be always higher than ambient temperature.

Ambient Temperature (°C)	Liquid Temperature	
	Min. (°C)	Max. (°C)
0	2	110
10	10	110
20	20	110
30	30	110
35	35	90
40	40	70

For domestic hot water, it is suggested that water temperature should remain below 65°C to reduce scaling.



## 13.2 Installation Dimensions

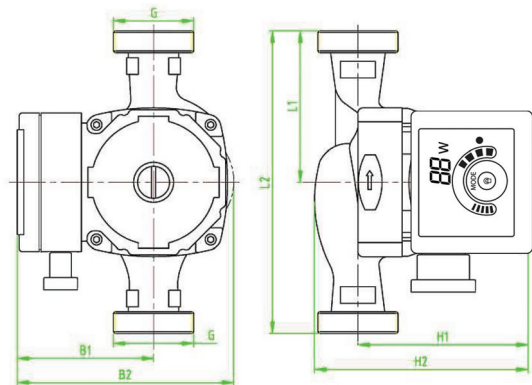

Max Power (W)	Min Power (W)	Product Model	Head	Material of Pump Body				Dimension (mm)						
				Cast Iron	Plastic	Copper	SS	L1	L2	B1	B2	H1	H2	G
32	5	MP100A	5	•				65	130	82	130	103	130	1 1/2"
45	5	MP200A	6	•				65	130	82	130	103	130	1 1/2"
45	5	MP280A	6	•				90	180	82	130	103	130	1 1/2"



### Warning

Before conducting any maintenance and repair of the motor pump, ensure that power supply has been cut off and will not be connected accidentally.

## 14. Warranty

SALUS Controls warrants that this product will be free from any defect in materials or workmanship, and shall perform in accordance with its specification, for a period of five years from the date of installation. SALUS Controls sole liability for breach of this warranty will be (at its option) to repair or replace the defective product.

Customer Name: .....

Customer Address: .....

..... Post Code: .....

Tel No: ..... Email: .....

Engineers Company: .....

Tel No: ..... Email: .....

Installation Date: .....

Engineers Name: .....

Engineers Signature: .....

# Energy Saving A Rated Circulating Pump

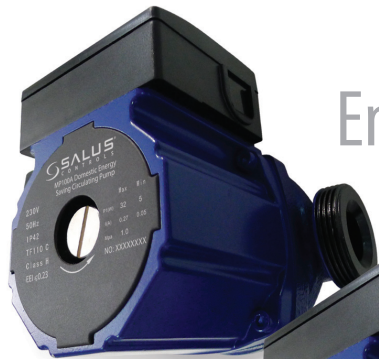

MP100A



MP200A



MP280A

## SALUS Controls plc

SALUS House

Dodworth Business Park South,

Whinby Road,

Dodworth, Barnsley S75 3SP

UK.

**SALES:** T: +44 (0) 1226 323961  
E: sales@salus-tech.com

**TECHNICAL:** T: +44 (0) 1226 323961  
E: tech@salus-tech.com

# www.salus-controls.com



SALUS Controls is a member of the Computime Group

Maintaining a policy of continued product development SALUS Controls plc reserve the right to change specification, design and materials of products listed in this brochure without prior notice.

**Issue Date: Sept 2013**

00087



RoHS EEI  $\leq 0.23$